



# **BIND 9 Administrator Reference Manual**

*Release 9.18.47*

**Internet Systems Consortium**

**2026-03-13**

# CONTENTS

<b>1</b>	<b>Introduction to DNS and BIND 9</b>	<b>1</b>
1.1	Scope of Document . . . . .	1
1.2	Organization of This Document . . . . .	1
1.3	Conventions Used in This Document . . . . .	2
1.4	The Domain Name System (DNS) . . . . .	2
1.5	DNS Security Overview . . . . .	7
<b>2</b>	<b>Resource Requirements</b>	<b>9</b>
2.1	Hardware Requirements . . . . .	9
2.2	CPU Requirements . . . . .	9
2.3	Memory Requirements . . . . .	9
2.4	Name Server-Intensive Environment Issues . . . . .	9
2.5	Supported Platforms . . . . .	9
2.6	Unsupported Platforms . . . . .	11
2.7	Installing BIND 9 . . . . .	11
<b>3</b>	<b>Configurations and Zone Files</b>	<b>13</b>
3.1	Introduction . . . . .	13
3.2	Authoritative Name Servers . . . . .	16
3.3	Resolver (Caching Name Servers) . . . . .	21
3.4	Load Balancing . . . . .	29
3.5	Zone File . . . . .	30
<b>4</b>	<b>Name Server Operations</b>	<b>37</b>
4.1	Tools for Use With the Name Server Daemon . . . . .	37
4.2	Signals . . . . .	41
4.3	Plugins . . . . .	41
4.4	Configuring Plugins . . . . .	41
4.5	Developing Plugins . . . . .	42
<b>5</b>	<b>DNSSEC</b>	<b>43</b>
5.1	Zone Signing . . . . .	43
5.2	Secure Delegation . . . . .	48
5.3	DNSSEC Validation . . . . .	49
5.4	Dynamic Trust Anchor Management . . . . .	50
5.5	PKCS#11 (Cryptoki) Support . . . . .	51
<b>6</b>	<b>Advanced Configurations</b>	<b>55</b>
6.1	Dynamic Update . . . . .	55
6.2	NOTIFY . . . . .	56
6.3	Incremental Zone Transfers (IXFR) . . . . .	56

6.4	Split DNS . . . . .	56
6.5	IPv6 Support in BIND 9 . . . . .	59
6.6	Dynamically Loadable Zones (DLZ) . . . . .	60
6.7	Dynamic Database (DynDB) . . . . .	62
6.8	Catalog Zones . . . . .	63
6.9	DNS Firewalls and Response Policy Zones . . . . .	67
<b>7</b>	<b>Security Configurations</b>	<b>77</b>
7.1	Security Assumptions . . . . .	77
7.2	Access Control Lists . . . . .	78
7.3	Chroot and Setuid . . . . .	79
7.4	Dynamic Update Security . . . . .	80
7.5	TSIG . . . . .	80
7.6	TKEY . . . . .	82
7.7	SIG(0) . . . . .	83
<b>8</b>	<b>Configuration Reference</b>	<b>85</b>
8.1	Configuration File (named.conf) . . . . .	85
8.2	Blocks . . . . .	90
8.3	Statements . . . . .	258
8.4	Statements by Tag . . . . .	285
8.5	BIND 9 Statistics . . . . .	313
<b>9</b>	<b>Troubleshooting</b>	<b>321</b>
9.1	Common Problems . . . . .	321
9.2	Incrementing and Changing the Serial Number . . . . .	322
9.3	Where Can I Get Help? . . . . .	323
<b>10</b>	<b>Building BIND 9</b>	<b>325</b>
10.1	Required Libraries . . . . .	325
10.2	Optional Features . . . . .	326
10.3	macOS . . . . .	327
<b>11</b>	<b>DNSSEC Guide</b>	<b>329</b>
11.1	Preface . . . . .	329
11.2	Introduction . . . . .	330
11.3	Getting Started . . . . .	335
11.4	Validation . . . . .	336
11.5	Signing . . . . .	348
11.6	Basic DNSSEC Troubleshooting . . . . .	368
11.7	Advanced Discussions . . . . .	376
11.8	Recipes . . . . .	389
11.9	Commonly Asked Questions . . . . .	409
<b>12</b>	<b>Manual Pages</b>	<b>413</b>
12.1	arpaname - translate IP addresses to the corresponding ARPA names . . . . .	413
12.2	ddns-confgen - TSIG key generation tool . . . . .	413
12.3	delv - DNS lookup and validation utility . . . . .	414
12.4	dig - DNS lookup utility . . . . .	418
12.5	dnssec-cds - change DS records for a child zone based on CDS/CDNSKEY . . . . .	428
12.6	dnssec-dsfromkey - DNSSEC DS RR generation tool . . . . .	431
12.7	dnssec-importkey - import DNSKEY records from external systems so they can be managed . . . . .	432
12.8	dnssec-keyfromlabel - DNSSEC key generation tool . . . . .	434
12.9	dnssec-keygen: DNSSEC key generation tool . . . . .	437
12.10	dnssec-revoke - set the REVOKED bit on a DNSSEC key . . . . .	441

12.11	dnssec-settime: set the key timing metadata for a DNSSEC key . . . . .	442
12.12	dnssec-signzone - DNSSEC zone signing tool . . . . .	445
12.13	dnssec-verify - DNSSEC zone verification tool . . . . .	451
12.14	dnstap-read - print dnstap data in human-readable form . . . . .	452
12.15	filter-aaaa.so - filter AAAA in DNS responses when A is present . . . . .	453
12.16	host - DNS lookup utility . . . . .	454
12.17	mdig - DNS pipelined lookup utility . . . . .	456
12.18	named-checkconf - named configuration file syntax checking tool . . . . .	460
12.19	named-checkzone - zone file validation tool . . . . .	462
12.20	named-compilezone - zone file converting tool . . . . .	464
12.21	named-journalprint - print zone journal in human-readable form . . . . .	467
12.22	named-nzd2nzf - convert an NZD database to NZF text format . . . . .	467
12.23	named-rrchecker - syntax checker for individual DNS resource records . . . . .	468
12.24	named.conf - configuration file for <b>named</b> . . . . .	472
12.25	named - Internet domain name server . . . . .	491
12.26	nsec3hash - generate NSEC3 hash . . . . .	494
12.27	nslookup - query Internet name servers interactively . . . . .	495
12.28	nsupdate - dynamic DNS update utility . . . . .	498
12.29	rndc-confgen - rndc key generation tool . . . . .	503
12.30	rndc.conf - rndc configuration file . . . . .	504
12.31	rndc - name server control utility . . . . .	506
12.32	tsig-keygen - TSIG key generation tool . . . . .	514
<b>13</b>	<b>General DNS Reference Information</b> . . . . .	<b>515</b>
13.1	Requests for Comment (RFCs) . . . . .	515
13.2	Notes . . . . .	520
13.3	Internet Drafts . . . . .	520
<b>14</b>	<b>Release Notes</b> . . . . .	<b>521</b>
14.1	Introduction . . . . .	526
14.2	Supported Platforms . . . . .	527
14.3	Download . . . . .	527
14.4	Known Issues . . . . .	527
14.5	Notes for BIND 9.18.47 . . . . .	527
14.6	Notes for BIND 9.18.46 . . . . .	527
14.7	Notes for BIND 9.18.45 . . . . .	527
14.8	Notes for BIND 9.18.44 . . . . .	528
14.9	Notes for BIND 9.18.43 . . . . .	528
14.10	Notes for BIND 9.18.42 . . . . .	528
14.11	Notes for BIND 9.18.41 . . . . .	528
14.12	Notes for BIND 9.18.40 . . . . .	530
14.13	Notes for BIND 9.18.39 . . . . .	530
14.14	Notes for BIND 9.18.38 . . . . .	530
14.15	Notes for BIND 9.18.37 . . . . .	531
14.16	Notes for BIND 9.18.36 . . . . .	531
14.17	Notes for BIND 9.18.35 . . . . .	532
14.18	Notes for BIND 9.18.34 . . . . .	532
14.19	Notes for BIND 9.18.33 . . . . .	533
14.20	Notes for BIND 9.18.32 . . . . .	534
14.21	Notes for BIND 9.18.31 . . . . .	535
14.22	Notes for BIND 9.18.30 . . . . .	536
14.23	Notes for BIND 9.18.29 . . . . .	537
14.24	Notes for BIND 9.18.28 . . . . .	538
14.25	Notes for BIND 9.18.27 . . . . .	539

14.26	Notes for BIND 9.18.26	539
14.27	Notes for BIND 9.18.25	539
14.28	Notes for BIND 9.18.24	540
14.29	Notes for BIND 9.18.23	541
14.30	Notes for BIND 9.18.22	541
14.31	Notes for BIND 9.18.21	541
14.32	Notes for BIND 9.18.20	541
14.33	Notes for BIND 9.18.19	542
14.34	Notes for BIND 9.18.18	543
14.35	Notes for BIND 9.18.17	543
14.36	Notes for BIND 9.18.16	544
14.37	Notes for BIND 9.18.15	544
14.38	Notes for BIND 9.18.14	545
14.39	Notes for BIND 9.18.13	545
14.40	Notes for BIND 9.18.12	546
14.41	Notes for BIND 9.18.11	547
14.42	Notes for BIND 9.18.10	548
14.43	Notes for BIND 9.18.9	549
14.44	Notes for BIND 9.18.8	550
14.45	Notes for BIND 9.18.7	550
14.46	Notes for BIND 9.18.6	551
14.47	Notes for BIND 9.18.5	552
14.48	Notes for BIND 9.18.4	552
14.49	Notes for BIND 9.18.3	553
14.50	Notes for BIND 9.18.2	554
14.51	Notes for BIND 9.18.1	554
14.52	Notes for BIND 9.18.0	555
14.53	License	559
14.54	End of Life	560
14.55	Thank You	560
<b>15</b>	<b>Changelog</b>	<b>561</b>
15.1	BIND 9.18.47	561
15.2	BIND 9.18.46	561
15.3	BIND 9.18.45	561
15.4	BIND 9.18.44	562
15.5	BIND 9.18.43	562
15.6	BIND 9.18.42	563
15.7	BIND 9.18.41	563
15.8	BIND 9.18.40	565
15.9	BIND 9.18.39	565
15.10	BIND 9.18.38	566
15.11	BIND 9.18.37	567
15.12	BIND 9.18.36	567
15.13	BIND 9.18.35	568
15.14	BIND 9.18.34	569
15.15	BIND 9.18.33	570
15.16	BIND 9.18.32	572
15.17	BIND 9.18.31	574
15.18	BIND 9.18.30	575
15.19	BIND 9.18.29	577
15.20	Changes prior to 9.18.29	579
<b>16</b>	<b>A Brief History of the DNS and BIND</b>	<b>987</b>





## INTRODUCTION TO DNS AND BIND 9

The Internet Domain Name System (DNS) consists of:

- the syntax to specify the names of entities in the Internet in a hierarchical manner,
- the rules used for delegating authority over names, and
- the system implementation that actually maps names to Internet addresses.

DNS data is maintained in a group of distributed hierarchical databases.

### 1.1 Scope of Document

The Berkeley Internet Name Domain (BIND) software implements a domain name server for a number of operating systems. This document provides basic information about the installation and maintenance of Internet Systems Consortium (ISC) BIND version 9 software package for system administrators.

This manual covers BIND version 9.18.47.

### 1.2 Organization of This Document

*Introduction to DNS and BIND 9* introduces the basic DNS and BIND concepts. Some tutorial material on *The Domain Name System (DNS)* is presented for those unfamiliar with DNS. A *DNS Security Overview* is provided to allow BIND operators to implement appropriate security for their operational environment.

*Resource Requirements* describes the hardware and environment requirements for BIND 9 and lists both the supported and unsupported platforms.

*Configurations and Zone Files* is intended as a quickstart guide for newer users. Sample files are included for *Authoritative Name Servers* (both *primary* and *secondary*), as well as a simple *Resolver (Caching Name Servers)* and a *Forwarding Resolver Configuration*. Some reference material on the *Zone File* is included.

*Name Server Operations* covers basic BIND 9 software and DNS operations, including some useful tools, Unix signals, and plugins.

*Advanced Configurations* builds on the configurations of *Configurations and Zone Files*, adding functions and features the system administrator may need.

*Security Configurations* covers most aspects of BIND 9 security, including file permissions, running BIND 9 in a "jail," and securing file transfers and dynamic updates.

*DNSSEC* describes the theory and practice of cryptographic authentication of DNS information. The *DNSSEC Guide* is a practical guide to implementing DNSSEC.

*Configuration Reference* gives exhaustive descriptions of all supported blocks, statements, and grammars used in BIND 9's `named.conf` configuration file.

*Troubleshooting* provides information on identifying and solving BIND 9 and DNS problems. Information about bug-reporting procedures is also provided.

*Building BIND 9* is a definitive guide for those occasions where the user requires special options not provided in the standard Linux or Unix distributions.

The **Appendices** contain useful reference information, such as a bibliography and historic information related to BIND and the Domain Name System, as well as the current *man* pages for all the published tools.

## 1.3 Conventions Used in This Document

In this document, we generally use `fixed-width` text to indicate the following types of information:

- pathnames
- filenames
- URLs
- hostnames
- mailing list names
- new terms or concepts
- literal user input
- program output
- keywords
- variables

Text in "quotes," **bold text**, or *italics* is also used for emphasis or clarity.

## 1.4 The Domain Name System (DNS)

This is a brief description of the functionality and organization of the Domain Name System (DNS). It is provided to familiarize users with the concepts involved, the (often confusing) terminology used, and how all the parts fit together to form an operational system.

All network systems operate with network addresses, such as IPv4 and IPv6. The vast majority of humans find it easier to work with names rather than seemingly endless strings of network address digits. The earliest ARPANET systems (from which the Internet evolved) mapped names to addresses using a **hosts** file that was distributed to all entities whenever changes occurred. Operationally, such a system became rapidly unsustainable once there were more than 100 networked entities, which led to the specification and implementation of the Domain Name System that we use today.

### 1.4.1 DNS Fundamentals

The DNS naming system is organized as a tree structure comprised of multiple levels and thus it naturally creates a distributed system. Each node in the tree is given a label which defines its **Domain** (its area or zone) of **Authority**. The topmost node in the tree is the **Root Domain**; it delegates to **Domains** at the next level which are generically known as the **Top-Level Domains (TLDs)**. They in turn delegate to **Second-Level Domains (SLDs)**, and so on. The Top-Level Domains (TLDs) include a special group of TLDs called the **Country Code Top-Level Domains (ccTLDs)**, in which every country is assigned a unique two-character country code from ISO 3166 as its domain.

**Note**

The Domain Name System is controlled by ICANN (<https://www.icann.org>) (a 501c non-profit entity); their current policy is that any new TLD, consisting of three or more characters, may be proposed by any group of commercial sponsors and if it meets ICANN's criteria will be added to the TLDs.

The concept of delegation and authority flows down the DNS tree (the DNS hierarchy) as shown:

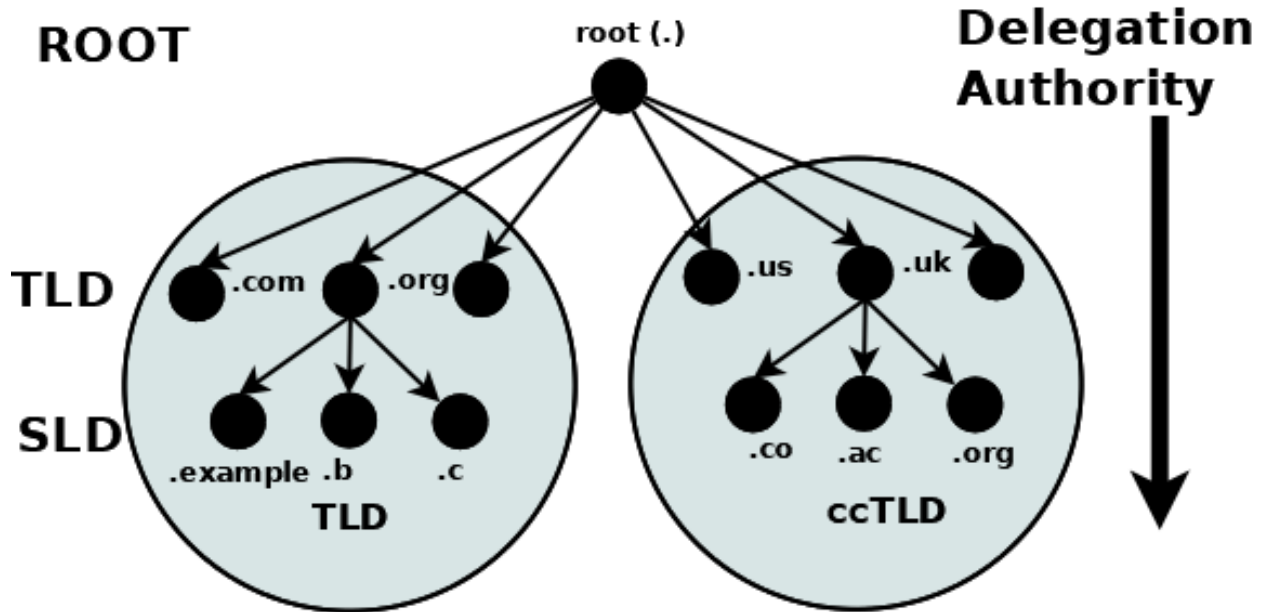

Fig. 1: Delegation and Authority in the DNS Name Space

A domain is the label of a node in the tree. A **domain name** uniquely identifies any node in the DNS tree and is written, left to right, by combining all the domain labels (each of which are unique within their parent's zone or domain of authority), with a dot separating each component, up to the root domain. In the above diagram the following are all domain names:

```
example.com
b.com
ac.uk
us
org
```

The root has a unique label of "." (dot), which is normally omitted when it is written as a domain name, but when it is written as a **Fully Qualified Domain Name (FQDN)** the dot must be present. Thus:

```
example.com      # domain name
example.com.    # FQDN
```

### 1.4.2 Authority and Delegation

Each domain (node) has been **delegated** the authority from its parent domain. The delegated authority includes specific responsibilities to ensure that every domain it delegates has a unique name or label within its zone or domain of authority, and that it maintains an **authoritative** list of its delegated domains. The responsibilities further include an operational requirement to operate two (or more) name servers (which may be contracted to a third party) which will contain the

authoritative data for all the domain labels within its zone of authority in a *zone file*. Again, the tree structure ensures that the DNS name space is naturally distributed.

The following diagram illustrates that **Authoritative Name Servers** exist for every level and every domain in the DNS name space:

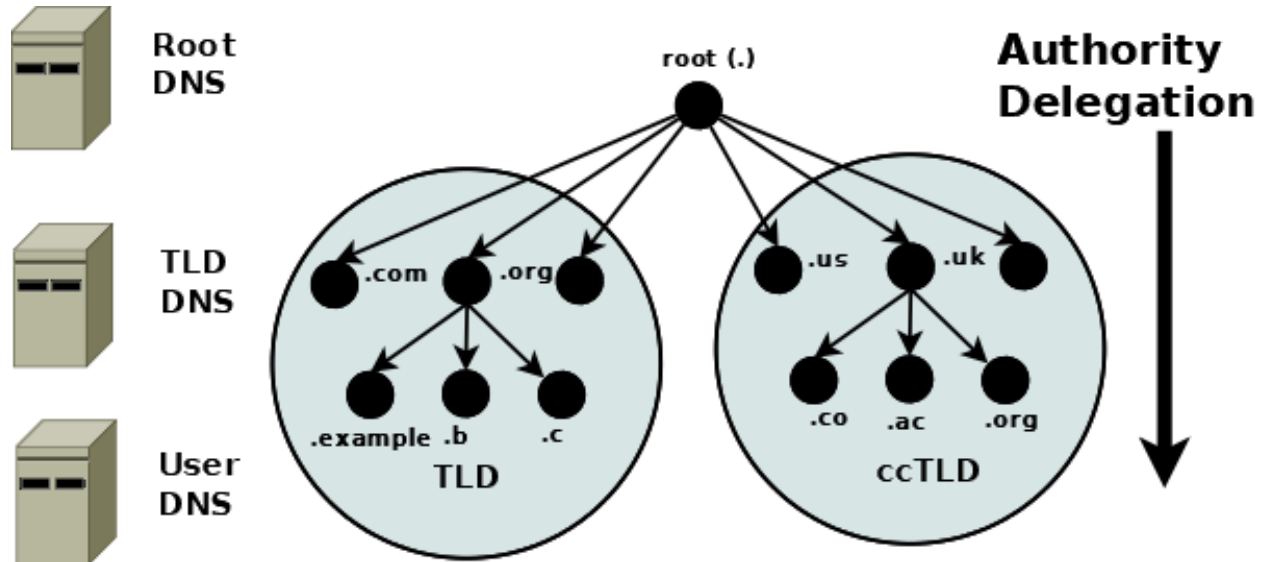

Fig. 2: Authoritative Name Servers in the DNS Name Space

**Note**

The difference between a domain and a zone can appear confusing. Practically, the terms are generally used synonymously in the DNS. If, however, you are into directed graphs and tree structure theory or similar exotica, a zone can be considered as an arc through any node (or domain) with the domain at its apex. The zone therefore encompasses all the name space below the domain. This can, however, lead to the concept of subzones and these were indeed defined in the original DNS specifications. Thankfully the term subzone has been lost in the mists of time.

### 1.4.3 Root Servers

The **root servers** are a critical part of the DNS authoritative infrastructure. There are 13 root servers (*a.root-servers.net* to *m.root-servers.net*). The number 13 is historically based on the maximum amount of name and IPv4 data that could be packed into a 512-byte UDP message, and not a perverse affinity for a number that certain cultures treat as unlucky. The 512-byte UDP data limit is no longer a limiting factor and all root servers now support both IPv4 and IPv6. In addition, almost all the root servers use **anycast**, with well over 300 instances of the root servers now providing service worldwide (see further information at <https://root-servers.org>). The root servers are the starting point for all **name resolution** within the DNS.

### 1.4.4 Name Resolution

So far all the emphasis has been on how the DNS stores its authoritative domain (zone) data. End-user systems use names (an email address or a web address) and need to access this authoritative data to obtain an IP address, which they use to contact the required network resources such as web, FTP, or mail servers. The process of converting a domain name to a result (typically an IP address, though other types of data may be obtained) is generically called **name resolution**, and is handled by **resolvers** (also known as **caching name servers** and many other terms). The following diagram shows the typical name resolution process:

## Name Resolution Authoritative Name Servers and Resolvers

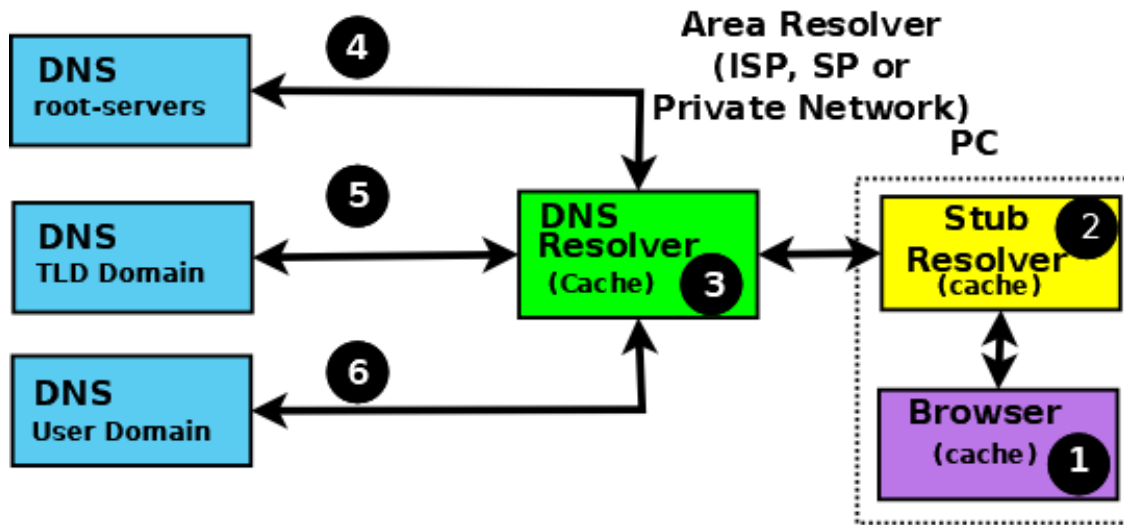

Fig. 3: Authoritative Name Servers and Name Resolution

An end-user application, such as a browser (1), when needing to resolve a name such as **www.example.com**, makes an internal system call to a minimal function resolution entity called a **stub resolver** (2). The stub resolver (using stored IP addresses) contacts a resolver (a caching name server or full-service resolver) (3), which in turn contacts all the necessary authoritative name servers (4, 5, and 6) to provide the answer that it then returns to the user (2, 1). To improve performance, all resolvers (including most stub resolvers) cache (store) their results such that a subsequent request for the same data is taken from the resolver's cache, removing the need to repeat the name resolution process and use time-consuming resources. All communication between the stub resolver, the resolver, and the authoritative name servers uses the DNS protocol's query and response message pair.

### 1.4.5 DNS Protocol and Queries

DNS **queries** use the UDP protocol over the reserved port 53 (but both TCP and TLS can optionally be used in some parts of the network).

The following diagram shows the name resolution process expressed in terms of DNS queries and responses.

The stub resolver sends a **recursive query** message (with the required domain name in the QUESTION section of the query) (2) to the resolver. A **recursive** query simply requests the resolver to find the complete answer. A stub resolver only ever sends recursive queries and always needs the service of a resolver. The response to a recursive query can be:

1. The answer to the user's QUESTION in the ANSWER section of the query response.
2. An error (such as NXDOMAIN - the name does not exist).

The resolver, on receipt of the user's recursive query, either responds immediately, if the ANSWER is in its cache, or accesses the DNS hierarchy to obtain the answer. The resolver always starts with root servers and sends an **iterative query** (4, 5, and 6). The response to an iterative query can be:

1. The answer to the resolver's QUESTION in the ANSWER section of the query response.
2. A **referral** (indicated by an empty ANSWER section but data in the AUTHORITY section, and typically IP addresses in the ADDITIONAL section of the response).
3. An error (such as NXDOMAIN - the name does not exist).

## Recursive and Iterative Queries

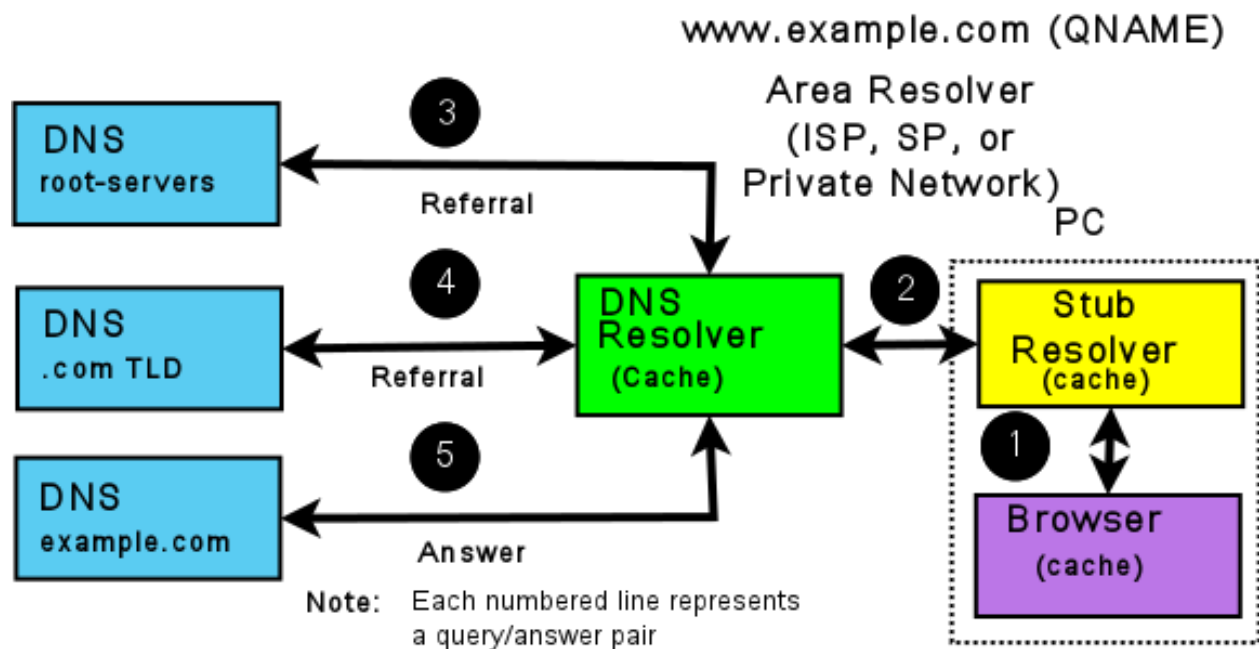

Item (2) is a Recursive query; one question gives one complete answer  
 Items (3), (4), and (5) are Iterative queries which may return either a referral, an answer, or an error

Fig. 4: Resolvers and Queries

If the response is either an answer or an error, these are returned immediately to the user (and cached for future use). If the response is a referral, the resolver needs to take additional action to respond to the user's recursive query.

A referral, in essence, indicates that the queried server does not know the answer (the ANSWER section of the response is empty), but it refers the resolver to the authoritative name servers (in the AUTHORITY section of the response) which it knows about in the domain name supplied in the QUESTION section of the query. Thus, if the QUESTION is for the domain name **www.example.com**, the root server to which the iterative query was sent adds a list of the **.com authoritative name servers** in the AUTHORITY section. The resolver selects one of the servers from the AUTHORITY section and sends an iterative query to it. Similarly, the .com authoritative name servers send a referral containing a list of the **example.com** authoritative name servers. This process continues down the DNS hierarchy until either an ANSWER or an error is received, at which point the user's original recursive query is sent a response.

#### **Note**

The DNS hierarchy is always accessed starting at the root servers and working down; there is no concept of "up" in the DNS hierarchy. Clearly, if the resolver has already cached the list of .com authoritative name servers and the user's recursive query QUESTION contains a domain name ending in .com, it can omit access to the root servers. However, that is simply an artifact (in this case a performance benefit) of caching and does not change the concept of top-down access within the DNS hierarchy.

The insatiably curious may find reading [RFC 1034](#) and [RFC 1035](#) a useful starting point for further information.

### 1.4.6 DNS and BIND 9

BIND 9 is a complete implementation of the DNS protocol. BIND 9 can be configured (using its `named.conf` file) as an authoritative name server, a resolver, and, on supported hosts, a stub resolver. While large operators usually dedicate DNS servers to a single function per system, smaller operators will find that BIND 9's flexible configuration features support multiple functions, such as a single DNS server acting as both an authoritative name server and a resolver.

Example configurations of basic *authoritative name servers* and *resolvers and forwarding resolvers*, as well as *advanced configurations* and *secure configurations*, are provided.

## 1.5 DNS Security Overview

DNS is a communications protocol. All communications protocols are potentially vulnerable to both subversion and eavesdropping. It is important for users to audit their exposure to the various threats within their operational environment and implement the appropriate solutions. BIND 9, a specific implementation of the DNS protocol, provides an extensive set of security features. The purpose of this section is to help users to select from the range of available security features those required for their specific user environment.

A generic DNS network is shown below, followed by text descriptions. In general, the further one goes from the left-hand side of the diagram, the more complex the implementation.

#### **Note**

Historically, DNS data was regarded as public and security was concerned, primarily, with ensuring the integrity of DNS data. DNS data privacy is increasingly regarded as an important dimension of overall security, specifically *DNS over TLS*.

The following notes refer to the numbered elements in the above diagram.

1. A variety of system administration techniques and methods may be used to secure BIND 9's local environment, including *file permissions*, running BIND 9 in a *jail*, and the use of *Access Control Lists*.

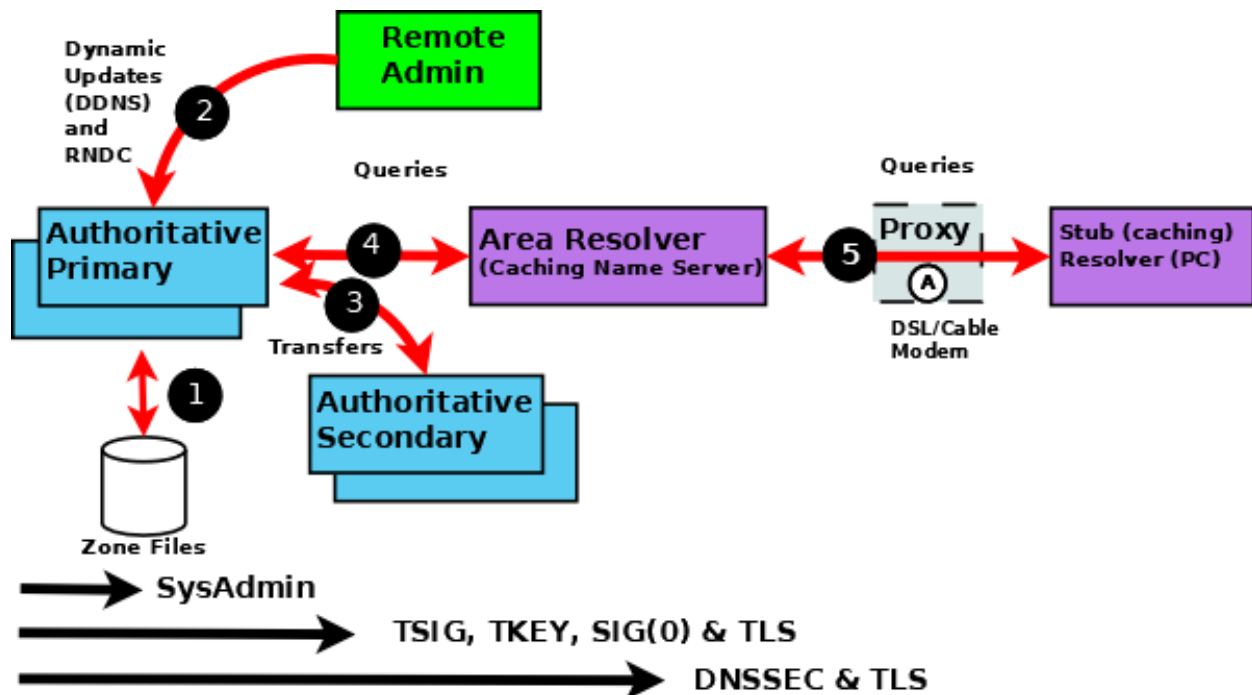

Fig. 5: BIND 9 Security Overview

2. The remote name daemon control (*rndc*) program allows the system administrator to control the operation of a name server. The majority of BIND 9 packages or ports come preconfigured with local (loopback address) security preconfigured. If *rndc* is being invoked from a remote host, further configuration is required. The *nsupdate* tool uses **Dynamic DNS (DDNS)** features and allows users to dynamically change the contents of the zone file(s). *nsupdate* access and security may be controlled using `named.conf statements` or via the *TSIG cryptographic method*. Clearly, if the remote hosts used for either *rndc* or DDNS lie within a network entirely under the user's control, the security threat may be regarded as non-existent. Any implementation requirements, therefore, depend on the site's security policy.

3. Zone transfer from a **primary** to one or more **secondary** authoritative name servers across a public network carries risk. The zone transfer may be secured using `named.conf statements`, *TSIG cryptographic methods*, or *TLS*. Clearly, if the secondary authoritative name server(s) all lie within a network entirely under the user's control, the security threat may be regarded as non-existent. Any implementation requirements again depend on the site's security policy.

4. If the operator of an authoritative name server (primary or secondary) wishes to ensure that DNS responses to user-initiated queries about the zone(s) for which they are responsible can only have come from their server, that the data received by the user is the same as that sent, and that non-existent names are genuine, then *DNSSEC* is the only solution. DNSSEC requires configuration and operational changes both to the authoritative name servers and to any resolver which accesses those servers.

5. The typical Internet-connected end-user device (PCs, laptops, and even mobile phones) either has a stub resolver or operates via a DNS proxy. A stub resolver requires the services of an area or full-service resolver to completely answer user queries. Stub resolvers on the majority of PCs and laptops typically have a caching capability to increase performance. At this time there are no standard stub resolvers or proxy DNS tools that implement DNSSEC. BIND 9 may be configured to provide such capability on supported Linux or Unix platforms. *DNS over TLS* may be configured to verify the integrity of the data between the stub resolver and area (or full-service) resolver. However, unless the resolver and the authoritative name server implements DNSSEC, end-to-end integrity (from authoritative name server to stub resolver) cannot be guaranteed.

## RESOURCE REQUIREMENTS

### 2.1 Hardware Requirements

DNS hardware requirements have traditionally been quite modest. For many installations, servers that have been retired from active duty have performed admirably as DNS servers.

However, the DNSSEC features of BIND 9 may be quite CPU-intensive, so organizations that make heavy use of these features may wish to consider larger systems for these applications. BIND 9 is fully multithreaded, allowing full utilization of multiprocessor systems for installations that need it.

### 2.2 CPU Requirements

CPU requirements for BIND 9 range from i386-class machines, for serving static zones without caching, to enterprise-class machines to process many dynamic updates and DNSSEC-signed zones, serving many thousands of queries per second.

### 2.3 Memory Requirements

Server memory must be sufficient to hold both the cache and the zones loaded from disk. The `max-cache-size` option can limit the amount of memory used by the cache, at the expense of reducing cache hit rates and causing more DNS traffic. It is still good practice to have enough memory to load all zone and cache data into memory; unfortunately, the best way to determine this for a given installation is to watch the name server in operation. After a few weeks, the server process should reach a relatively stable size where entries are expiring from the cache as fast as they are being inserted.

### 2.4 Name Server-Intensive Environment Issues

For name server-intensive environments, there are two configurations that may be used. The first is one where clients and any second-level internal name servers query the main name server, which has enough memory to build a large cache; this approach minimizes the bandwidth used by external name lookups. The second alternative is to set up second-level internal name servers to make queries independently. In this configuration, none of the individual machines need to have as much memory or CPU power as in the first alternative, but this has the disadvantage of making many more external queries, as none of the name servers share their cached data.

### 2.5 Supported Platforms

The current support status of BIND 9 versions across various platforms can be found in the ISC Knowledgebase:

<https://kb.isc.org/docs/supported-platforms>

In general, this version of BIND will build and run on any POSIX-compliant system with a C11-compliant C compiler, BSD-style sockets with RFC-compliant IPv6 support, POSIX-compliant threads, and the *required libraries*.

The following C11 features are used in BIND 9:

- Atomic operations support, either in the form of C11 atomics or `__atomic` builtin operations.
- Thread Local Storage support, either in the form of C11 `__Thread_local/thread_local`, or the `__thread` GCC extension.

The C11 variants are preferred.

ISC regularly tests BIND on many operating systems and architectures, but lacks the resources to test all of them. Consequently, ISC is only able to offer support on a “best-effort” basis for some.

## 2.5.1 Regularly Tested Platforms

Current versions of BIND 9 are fully supported and regularly tested on the following systems:

- Debian 12, 13
- Ubuntu LTS 22.04, 24.04
- Fedora 43
- Red Hat Enterprise Linux / CentOS / AlmaLinux 8, 9, 10
- FreeBSD 13, 14, 15
- Alpine Linux 3.23

The amd64 CPU architecture is fully supported and regularly tested.

## 2.5.2 Best-Effort

The following are platforms on which BIND is known to build and run. ISC makes every effort to fix bugs on these platforms, but may be unable to do so quickly due to lack of hardware, less familiarity on the part of engineering staff, and other constraints. None of these are tested regularly by ISC.

- macOS 10.12+
- Solaris 11
- NetBSD
- OpenBSD
- Other Linux distributions still supported by their vendors, such as:
  - Ubuntu 20.10+
  - Gentoo
  - Arch Linux
- OpenWRT/LEDE 17.01+
- Other CPU architectures (arm, arm64, mips64, ppc64, s390x)

## 2.5.3 Community-Maintained

These systems may not all have the required dependencies for building BIND easily available, although it is possible in many cases to compile those directly from source. The community and interested parties may wish to help with maintenance, and we welcome patch contributions, although we cannot guarantee that we will accept them. All contributions will be assessed against the risk of adverse effect on officially supported platforms.

- Platforms past or close to their respective EOL dates, such as:
  - Ubuntu 14.04, 16.04, 18.04, 20.04 (Ubuntu ESM releases are not supported)
  - CentOS 6
  - Debian 8 Jessie, 9 Stretch, 10 Buster, 11 Bullseye
  - Red Hat Enterprise Linux / CentOS / Oracle Linux 6, 7
  - Debian 8 Jessie, 9 Stretch, 10 Buster
  - FreeBSD 10.x, 11.x, 12.x
- Less common CPU architectures (i386, i686, mips, mipsel, sparc, ppc, and others)

## 2.6 Unsupported Platforms

These are platforms on which current versions of BIND 9 are known *not* to build or run:

- Platforms without at least OpenSSL 1.0.2
- Windows
- Solaris 10 and older
- Platforms that do not support IPv6 Advanced Socket API (RFC 3542)
- Platforms that do not support atomic operations (via compiler or library)
- Linux without NPTL (Native POSIX Thread Library)
- Platforms on which **libuv** cannot be compiled

## 2.7 Installing BIND 9

*Building BIND 9* contains complete instructions for how to build BIND 9.

The ISC [Knowledgebase](#) contains many useful articles about installing BIND 9 on specific platforms.



## CONFIGURATIONS AND ZONE FILES

### 3.1 Introduction

BIND 9 uses a single configuration file called *named.conf*, which is typically located in either */etc/namedb* or */usr/local/etc/namedb*.

#### Note

If *rndc* is being used locally (on the same host as BIND 9) then an additional file *rndc.conf* may be present, though *rndc* operates without this file. If *rndc* is being run from a remote host then an *rndc.conf* file must be present as it defines the link characteristics and properties.

Depending on the functionality of the system, one or more zone files is required.

The samples given throughout this and subsequent chapters use a standard base format for both the *named.conf* and the zone files for **example.com**. The intent is for the reader to see the evolution from a common base as features are added or removed.

#### 3.1.1 *named.conf* Base File

This file illustrates the typical format and layout style used for *named.conf* and provides a basic logging service, which may be extended as required by the user.

```
// base named.conf file
// Recommended that you always maintain a change log in this file as shown here
// options clause defining the server-wide properties
options {
    // all relative paths use this directory as a base
    directory "/var";
    // version statement for security to avoid hacking known weaknesses
    // if the real version number is revealed
    version "not currently available";
};

// logging clause
// log to /var/log/named/example.log all events from info UP in severity (no debug)
// uses 3 files in rotation swaps files when size reaches 250K
// failure messages that occur before logging is established are
// in syslog (/var/log/messages)
//
logging {
```

(continues on next page)

(continued from previous page)

```

channel example_log {
    // uses a relative path name and the directory statement to
    // expand to /var/log/named/example.log
    file "log/named/example.log" versions 3 size 250k;
    // only log info and up messages - all others discarded
    severity info;
};
category default {
    example_log;
};
};

```

The *logging* and *options* blocks and *category*, *channel*, *directory*, *file*, and *severity* statements are all described further in the appropriate sections of this ARM.

### 3.1.2 example.com base zone file

The following is a complete zone file for the domain **example.com**, which illustrates a number of common features. Comments in the file explain these features where appropriate. Zone files consist of *Resource Records (RR)*, which describe the zone's characteristics or properties.

```

1 ; base zone file for example.com
2 $TTL 2d ; default TTL for zone
3 $ORIGIN example.com. ; base domain-name
4 ; Start of Authority RR defining the key characteristics of the zone (domain)
5 @ IN SOA ns1.example.com. hostmaster.example.com. (
6     2003080800 ; serial number
7     12h ; refresh
8     15m ; update retry
9     3w ; expiry
10    2h ; minimum
11 )
12 ; name server RR for the domain
13 IN NS ns1.example.com.
14 ; the second name server is external to this zone (domain)
15 IN NS ns2.example.net.
16 ; mail server RRs for the zone (domain)
17 3w IN MX 10 mail.example.com.
18 ; the second mail servers is external to the zone (domain)
19 IN MX 20 mail.example.net.
20 ; domain hosts includes NS and MX records defined above
21 ; plus any others required
22 ; for instance a user query for the A RR of joe.example.com will
23 ; return the IPv4 address 192.168.254.6 from this zone file
24 ns1 IN A 192.168.254.2
25 mail IN A 192.168.254.4
26 joe IN A 192.168.254.6
27 www IN A 192.168.254.7
28 ; aliases ftp (ftp server) to an external domain
29 ftp IN CNAME ftp.example.net.

```

This type of zone file is frequently referred to as a **forward-mapped zone file**, since it maps domain names to some other value, while a *reverse-mapped zone file* maps an IP address to a domain name. The zone file is called **example.com**

for no good reason except that it is the domain name of the zone it describes; as always, users are free to use whatever file-naming convention is appropriate to their needs.

### 3.1.3 Other Zone Files

Depending on the configuration additional zone files may or should be present. Their format and functionality are briefly described here.

### 3.1.4 localhost Zone File

All end-user systems are shipped with a `hosts` file (usually located in `/etc`). This file is normally configured to map the name **localhost** (the name used by applications when they run locally) to the loopback address. It is argued, reasonably, that a forward-mapped zone file for **localhost** is therefore not strictly required. This manual does use the BIND 9 distribution file `localhost-forward.db` (normally in `/etc/namedb/master` or `/usr/local/etc/namedb/master`) in all configuration samples for the following reasons:

1. Many users elect to delete the `hosts` file for security reasons (it is a potential target of serious domain name redirection/poisoning attacks).
2. Systems normally lookup any name (including domain names) using the `hosts` file first (if present), followed by DNS. However, the `nsswitch.conf` file (typically in `/etc`) controls this order (normally **hosts: file dns**), allowing the order to be changed or the **file** value to be deleted entirely depending on local needs. Unless the BIND administrator controls this file and knows its values, it is unsafe to assume that **localhost** is forward-mapped correctly.
3. As a reminder to users that unnecessary queries for **localhost** form a non-trivial volume of DNS queries on the public network, which affects DNS performance for all users.

Users may, however, elect at their discretion not to implement this file since, depending on the operational environment, it may not be essential.

The BIND 9 distribution file `localhost-forward.db` format is shown for completeness and provides for both IPv4 and IPv6 localhost resolution. The zone (domain) name is **localhost**.

```
$TTL 3h
localhost. SOA      localhost. nobody.localhost. 42 1d 12h 1w 3h
             NS      localhost.
             A       127.0.0.1
             AAAA    :::1
```

**Note**

Readers of a certain age or disposition may note the reference in this file to the late, lamented Douglas Noel Adams.

### 3.1.5 localhost Reverse-Mapped Zone File

This zone file allows any query requesting the name associated with the loopback IP (127.0.0.1). This file is required to prevent unnecessary queries from reaching the public DNS hierarchy. The BIND 9 distribution file `localhost.rev` is shown for completeness:

```
$TTL 1D
@           IN      SOA  localhost. root.localhost. (
                2007091701 ; serial
                30800      ; refresh
                7200       ; retry
```

(continues on next page)

(continued from previous page)

		604800	; expire
		300 )	; minimum
	IN	NS	localhost.
1	IN	PTR	localhost.

### 3.2 Authoritative Name Servers

These provide authoritative answers to user queries for the zones they support: for instance, the zone data describing the domain name **example.com**. An authoritative name server may support one or many zones.

Each zone may be defined as either a **primary** or a **secondary**. A primary zone reads its zone data directly from a file system. A secondary zone obtains its zone data from the primary zone using a process called **zone transfer**. Both the primary and the secondary zones provide authoritative data for their zone; there is no difference in the answer to a query from a primary or a secondary zone. An authoritative name server may support any combination of primary and secondary zones.

**Note**

The terms **primary** and **secondary** do not imply any access priority. Resolvers (name servers that provide the complete answers to user queries) are not aware of (and cannot find out) whether an authoritative answer comes from the primary or secondary name server. Instead, the resolver uses the list of authoritative servers for the zone (there must be at least two) and maintains a Round Trip Time (RTT) - the time taken to respond to the query - for each server in the list. The resolver uses the lowest-value server (the fastest) as its preferred server for the zone and continues to do so until its RTT becomes higher than the next slowest in its list, at which time that one becomes the preferred server.

For reasons of backward compatibility BIND 9 treats "primary" and "master" as synonyms, as well as "secondary" and "slave."

The following diagram shows the relationship between the primary and secondary name servers. The text below explains the process in detail.

The numbers in parentheses in the following text refer to the numbered items in the diagram above.

1. The authoritative primary name server always loads (or reloads) its zone files from (1) a local or networked filestore.
2. The authoritative secondary name server always loads its zone data from a primary via a **zone transfer** operation. Zone transfer may use **AXFR** (complete zone transfer) or **IXFR** (incremental zone transfer), but only if both primary and secondary name servers support the service. The zone transfer process (either AXFR or IXFR) works as follows:
  - a) The secondary name server for the zone reads (3 and 4) the *SOA RR* periodically. The interval is defined by the **refresh** parameter of the Start of Authority (SOA) RR.
  - b) The secondary compares the **serial number** parameter of the SOA RR received from the primary with the serial number in the SOA RR of its current zone data.
  - c) If the received serial number is arithmetically greater (higher) than the current one, the secondary initiates a zone transfer (5) using AXFR or IXFR (depending on the primary and secondary configuration), using TCP over port 53 (6).
3. The typically recommended zone refresh times for the SOA RR (the time interval when the secondary reads or polls the primary for the zone SOA RR) are multiples of hours to reduce traffic loads. Worst-case zone change propagation can therefore take extended periods.
4. The optional NOTIFY (**RFC 1996**) feature (2) is automatically configured; use the *notify* statement to turn off the feature. Whenever the primary loads or reloads a zone, it sends a NOTIFY message to the configured

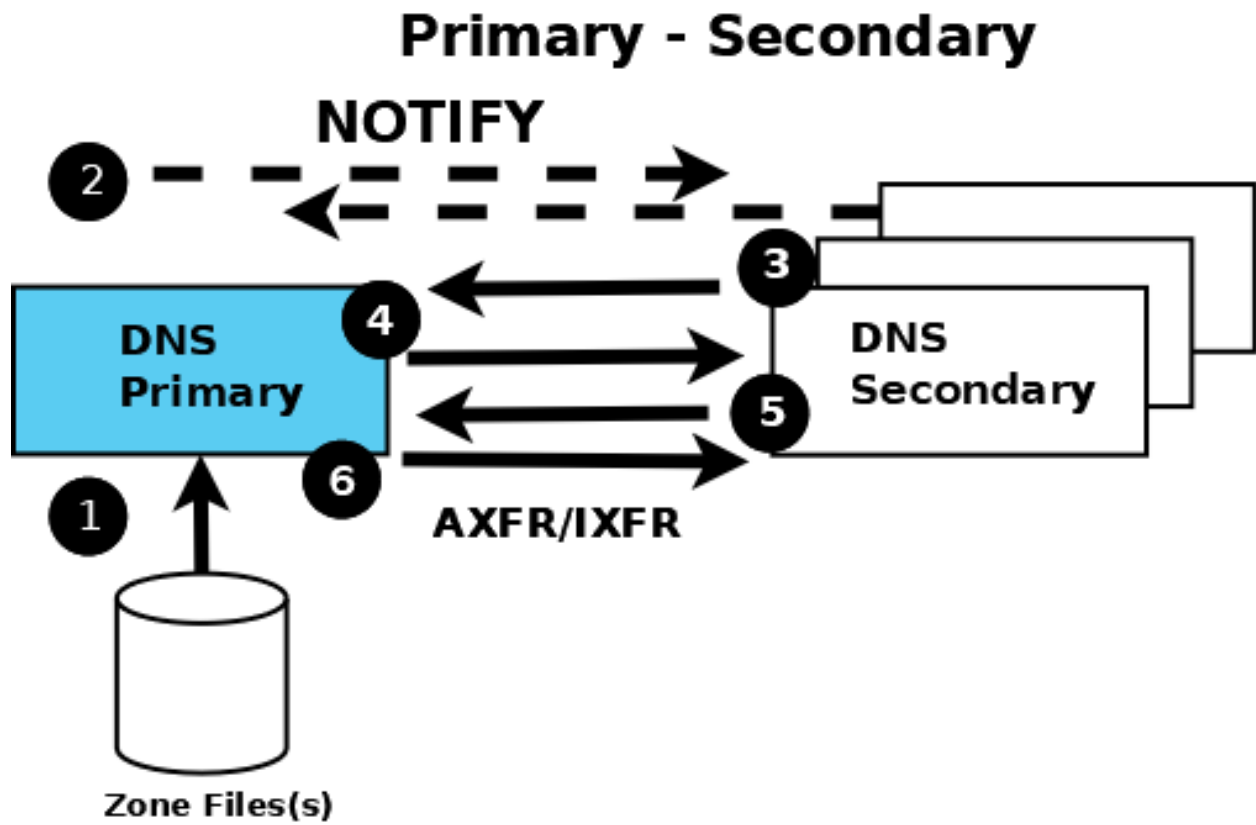

Fig. 1: Authoritative Primary and Secondary Name Servers

secondary (or secondaries) and may optionally be configured to send the NOTIFY message to other hosts using the *also-notify* statement. The NOTIFY message simply indicates to the secondary that the primary has loaded or reloaded the zone. On receipt of the NOTIFY message, the secondary responds to indicate it has received the NOTIFY and immediately reads the SOA RR from the primary (as described in section 2 a. above). If the zone file has changed, propagation is practically immediate.

The authoritative samples all use NOTIFY but identify the statements used, so that they can be removed if not required.

### 3.2.1 Primary Authoritative Name Server

The zone files are unmodified *from the base samples* but the *named.conf* file has been modified as shown:

```
// authoritative primary named.conf file
// options clause defining the server-wide properties
options {
    // all relative paths use this directory as a base
    directory "/var";
    // version statement for security to avoid hacking known weaknesses
    // if the real version number is revealed
    version "not currently available";
    // This is the default - allows user queries from any IP
    allow-query { any; };
    // normal server operations may place items in the cache
    // this prevents any user query from accessing these items
    // only authoritative zone data will be returned
    allow-query-cache { none; };
    // Do not provide recursive service to user queries
    recursion no;
};
// logging clause
// log to /var/log/named/example.log all events from info UP in severity (no debug)
// uses 3 files in rotation swaps files when size reaches 250K
// failure messages that occur before logging is established are
// in syslog (/var/log/messages)
//
logging {
    channel example_log {
        // uses a relative path name and the directory statement to
        // expand to /var/log/named/example.log
        file "log/named/example.log" versions 3 size 250k;
        // only log info and up messages - all others discarded
        severity info;
    };
    category default {
        example_log;
    };
};
// Provide forward mapping zone for localhost
// (optional)
zone "localhost" {
    type primary;
    file "master/localhost-forward.db";
    notify no;
};
```

(continues on next page)

(continued from previous page)

```
// Provide reverse mapping zone for the loopback
// address 127.0.0.1
zone "0.0.127.in-addr.arpa" {
    type primary;
    file "localhost.rev";
    notify no;
};
// We are the primary server for example.com
zone "example.com" {
    // this is the primary name server for the zone
    type primary;
    file "example.com";
    // this is the default
    notify yes;
    // IP addresses of secondary servers allowed to
    // transfer example.com from this server
    allow-transfer {
        192.168.4.14;
        192.168.5.53;
    };
};
```

The added statements and blocks are commented in the above file.

The `zone` block, and `allow-query`, `allow-query-cache`, `allow-transfer`, `file`, `notify`, `recursion`, and `type` statements are described in detail in the appropriate sections.

### 3.2.2 Secondary Authoritative Name Server

The zone files `local-host-forward.db` and `localhost.rev` are unmodified *from the base samples*. The **example.com** zone file is not required (the zone file is obtained from the primary via zone transfer). The `named.conf` file has been modified as shown:

```
// authoritative secondary named.conf file
// options clause defining the server-wide properties
options {
    // all relative paths use this directory as a base
    directory "/var";
    // version statement for security to avoid hacking known weaknesses
    // if the real version number is revealed
    version "not currently available";
    // This is the default - allows user queries from any IP
    allow-query { any; };
    // normal server operations may place items in the cache
    // this prevents any user query from accessing these items
    // only authoritative zone data will be returned
    allow-query-cache { none; };
    // Do not provide recursive service to user queries
    recursion no;
};
// logging clause
// log to /var/log/named/example.log all events from info UP in severity (no debug)
// uses 3 files in rotation swaps files when size reaches 250K
```

(continues on next page)

(continued from previous page)

```
// failure messages that occur before logging is established are
// in syslog (/var/log/messages)
//
logging {
  channel example_log {
    // uses a relative path name and the directory statement to
    // expand to /var/log/named/example.log
    file "log/named/example.log" versions 3 size 250k;
    // only log info and up messages - all others discarded
    severity info;
  };
  category default {
    example_log;
  };
};
// Provide forward mapping zone for localhost
// (optional)
zone "localhost" {
  type primary;
  file "master/localhost-forward.db";
  notify no;
};
// Provide reverse mapping zone for the loopback
// address 127.0.0.1
zone "0.0.127.in-addr.arpa" {
  type primary;
  file "localhost.rev";
  notify no;
};
// We are the secondary server for example.com
zone "example.com" {
  // this is a secondary server for the zone
  type secondary;
  // the file statement here allows the secondary to save
  // each zone transfer so that in the event of a program restart
  // the zone can be loaded immediately and the server can start
  // to respond to queries without waiting for a zone transfer
  file "example.com.saved";
  // IP address of example.com primary server
  primaries { 192.168.254.2; };
};
```

The statements and blocks added are all commented in the above file.

The `zone` block, and `allow-query`, `allow-query-cache`, `allow-transfer`, `file`, `primaries`, `recursion`, and `type` statements are described in detail in the appropriate sections.

If NOTIFY is not being used, no changes are required in this `named.conf` file, since it is the primary that initiates the NOTIFY message.

**Note**

Just when the reader thought they understood primary and secondary, things can get more complicated. A secondary zone can also be a primary to other secondaries: *named*, by default, sends NOTIFY messages for every zone it loads. Specifying *notify primary-only*; in the *zone* block for the secondary causes *named* to only send NOTIFY messages for primary zones that it loads.

### 3.3 Resolver (Caching Name Servers)

Resolvers handle *recursive user queries* and provide complete answers; that is, they issue one or more *iterative queries* to the DNS hierarchy. Having obtained a complete answer (or an error), a resolver passes the answer to the user and places it in its cache. Subsequent user requests for the same query will be answered from the resolver's cache until the *TTL* of the cached answer has expired, when it will be flushed from the cache; the next user query that requests the same information results in a new series of queries to the DNS hierarchy.

Resolvers are frequently referred to by a bewildering variety of names, including caching name servers, recursive name servers, forwarding resolvers, area resolvers, and full-service resolvers.

The following diagram shows how resolvers can function in a typical networked environment:

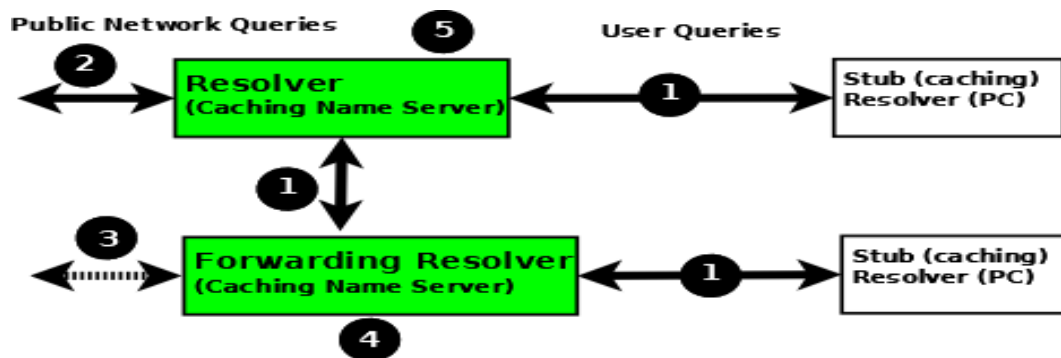

#### Resolver and Forwarding Resolver

1. End-user systems are all distributed with a local **stub resolver** as a standard feature. Today, the majority of stub resolvers also provide a local cache service to speed up user response times.
2. A stub resolver has limited functionality; specifically, it cannot follow *referrals*. When a stub resolver receives a request for a name from a local program, such as a browser, and the answer is not in its local cache, it sends a *recursive user query* (1) to a locally configured resolver (5), which may have the answer available in its cache. If it does not, it issues *iterative queries* (2) to the DNS hierarchy to obtain the answer. The resolver to which the local system sends the user query is configured, for Linux and Unix hosts, in `/etc/resolv.conf`; for Windows users it is configured or changed via the Control Panel or Settings interface.
3. Alternatively, the user query can be sent to a **forwarding resolver** (4). Forwarding resolvers on first glance look fairly pointless, since they appear to be acting as a simple pass-through and, like the stub resolver, require a full-service resolver (5). However, forwarding resolvers can be very powerful additions to a network for the following reasons:
  - a) Cost and Performance. Each **recursive user query** (1) at the forwarding resolver (4) results in two messages - the query and its answer. The resolver (5) may have to issue three, four, or more query pairs (2) to get the required answer. Traffic is reduced dramatically, increasing performance or reducing cost (if the link is tariffed). Additionally, since the forwarding resolver is typically shared across multiple hosts, its cache is more likely to contain answers, again improving user performance.

- b) Network Maintenance. Forwarding resolvers (4) can be used to ease the burden of local administration by providing a single point at which changes to remote name servers can be managed, rather than having to update all hosts. Thus, all hosts in a particular network section or area can be configured to point to a forwarding resolver, which can be configured to stream DNS traffic as desired and changed over time with minimal effort.
  - c) Sanitizing Traffic. Especially in larger private networks it may be sensible to stream DNS traffic using a forwarding resolver structure. The forwarding resolver (4) may be configured, for example, to handle all in-domain traffic (relatively safe) and forward all external traffic to a **hardened** resolver (5).
  - d) Stealth Networks. Forwarding resolvers are extensively used in *stealth or split networks*.
4. Forwarding resolvers (4) can be configured to forward all traffic to a resolver (5), or to only forward selective traffic (5) while directly resolving other traffic (3).

**⚠ Attention**

While the diagram above shows **recursive user queries** arriving via interface (1), there is nothing to stop them from arriving via interface (2) via the public network. If no limits are placed on the source IPs that can send such queries, the resolver is termed an **open resolver**. Indeed, when the world was young this was the way things worked on the Internet. Much has changed and what seems to be a friendly, generous action can be used by rogue actors to cause all kinds of problems including **Denial of Service (DoS)** attacks. Resolvers should always be configured to limit the IP addresses that can use their services. BIND 9 provides a number of statements and blocks to simplify defining these IP limits and configuring a **closed resolver**. The resolver samples given here all configure closed resolvers using a variety of techniques.

### 3.3.1 Additional Zone Files

#### Root Servers (Hint) Zone File

Resolvers (although not necessarily forwarding resolvers) need to access the DNS hierarchy. To do this, they need to know the addresses (IPv4 and/or IPv6) of the 13 *root servers*. This is done by the provision of a root server zone file, which is contained in the standard BIND 9 distribution as the file named `.root` (normally found in `/etc/namedb` or `/usr/local/namedb`). This file may also be obtained from the IANA website (<https://www.iana.org/domains/root/files>).

**i Note**

Many distributions rename this file for historical reasons. Consult the appropriate distribution documentation for the actual file name.

The hint zone file is referenced using the `type hint` statement and a zone (domain) name of "." (the generally silent dot).

**i Note**

The root server IP addresses have been stable for a number of years and are likely to remain stable for the near future. BIND 9 has a root-server list in its executable such that even if this file is omitted, out-of-date, or corrupt BIND 9 can still function. For this reason, many sample configurations omit the hints file. All the samples given here include the hints file primarily as a reminder of the functionality of the configuration, rather than as an absolute necessity.

## Private IP Reverse Map Zone Files

Resolvers are configured to send *iterative queries* to the public DNS hierarchy when the information requested is not in their cache or not defined in any local zone file. Many networks make extensive use of private IP addresses (defined by [RFC 1918](#), [RFC 2193](#), [RFC 5737](#), and [RFC 6598](#)). By their nature these IP addresses are forward-mapped in various user zone files. However, certain applications may issue **reverse map** queries (mapping an IP address to a name). If the private IP addresses are not defined in one or more reverse-mapped zone file(s), the resolver sends them to the DNS hierarchy where they are simply useless traffic, slowing down DNS responses for all users.

Private IP addresses may be defined using standard *reverse-mapping techniques* or using the `empty-zones-enable` statement. By default this statement is set to `empty-zones-enable yes`; and thus automatically prevents unnecessary DNS traffic by sending an NXDOMAIN error response (indicating the name does not exist) to any request. However, some applications may require a genuine answer to such reverse-mapped requests or they will fail to function. Mail systems in particular perform reverse DNS queries as a first-line spam check; in this case a reverse-mapped zone file is essential. The sample configuration files given here for both the resolver and the forwarding resolver provide a reverse-mapping zone file for the private IP address 192.168.254.4, which is the mail server address in the *base zone file*, as an illustration of the reverse-map technique. The file is named `192.168.254.rev` and has a zone name of **254.168.192.in-addr.arpa**.

```
; reverse map zone file for 192.168.254.4 only
$TTL 2d ; 172800 seconds
$ORIGIN 254.168.192.IN-ADDR.ARPA.
@      IN      SOA      ns1.example.com. hostmaster.example.com. (
                                2003080800 ; serial number
                                3h          ; refresh
                                15m         ; update retry
                                3w          ; expiry
                                3h          ; nx = nxdomain ttl
                                )
; only one NS is required for this local file
; and is an out of zone name
      IN      NS       ns1.example.com.
; other IP addresses can be added as required
; this maps 192.168.254.4 as shown
4      IN      PTR      mail.example.com. ; fully qualified domain name (FQDN)
```

## 3.3.2 Resolver Configuration

The resolver provides *recursive query support* to a defined set of IP addresses. It is therefore a **closed** resolver and cannot be used in wider network attacks.

```
// resolver named.conf file
// Two corporate subnets we wish to allow queries from
// defined in an acl clause
acl corpnets {
    192.168.4.0/24;
    192.168.7.0/24;
};

// options clause defining the server-wide properties
options {
    // all relative paths use this directory as a base
    directory "/var";
    // version statement for security to avoid hacking known weaknesses
    // if the real version number is revealed
```

(continues on next page)

(continued from previous page)

```
version "not currently available";
// this is the default
recursion yes;
// recursive queries only allowed from these ips
// and references the acl clause
allow-query { corpnets; };
// this ensures that any reverse map for private IPs
// not defined in a zone file will *not* be passed to the public network
// it is the default value
empty-zones-enable yes;
};

// logging clause
// log to /var/log/named/example.log all events from info UP in severity (no debug)
// uses 3 files in rotation swaps files when size reaches 250K
// failure messages that occur before logging is established are
// in syslog (/var/log/messages)
//
logging {
  channel example_log {
    // uses a relative path name and the directory statement to
    // expand to /var/log/named/example.log
    file "log/named/example.log" versions 3 size 250k;
    // only log info and up messages - all others discarded
    severity info;
  };
  category default {
    example_log;
  };
};

// zone file for the root servers
// discretionary zone (see root server discussion above)
zone "." {
  type hint;
  file "named.root";
};

// zone file for the localhost forward map
// discretionary zone depending on hosts file (see discussion)
zone "localhost" {
  type primary;
  file "masters/localhost-forward.db";
  notify no;
};

// zone file for the loopback address
// necessary zone
zone "0.0.127.in-addr.arpa" {
  type primary;
  file "localhost.rev";
  notify no;
};
```

(continues on next page)

(continued from previous page)

```
};

// zone file for local IP reverse map
// discretionary file depending on requirements
zone "254.168.192.in-addr.arpa" {
    type primary;
    file "192.168.254.rev";
    notify no;
};
```

The *zone* and *acl* blocks, and the *allow-query*, *empty-zones-enable*, *file*, *notify*, *recursion*, and *type* statements are described in detail in the appropriate sections.

As a reminder, the configuration of this resolver does **not** access the DNS hierarchy (does not use the public network) for any recursive query for which:

1. The answer is already in the cache.
2. The domain name is **localhost** (zone localhost).
3. Is a reverse-map query for 127.0.0.1 (zone 0.0.127.in-addr.arpa).
4. Is a reverse-map query for 192.168.254/24 (zone 254.168.192.in-addr.arpa).
5. Is a reverse-map query for any local IP (*empty-zones-enable* statement).

All other recursive queries will result in access to the DNS hierarchy to resolve the query.

### 3.3.3 Forwarding Resolver Configuration

This forwarding resolver configuration forwards all recursive queries, other than those for the defined zones and those for which the answer is already in its cache, to a full-service resolver at the IP address 192.168.250.3, with an alternative at 192.168.230.27. The forwarding resolver will cache all responses from these servers. The configuration is closed, in that it defines those IPs from which it will accept recursive queries.

A second configuration in which selective forwarding occurs *is also provided*.

```
// forwarding named.conf file
// Two corporate subnets we wish to allow queries from
// defined in an acl clause
acl corpnets {
    192.168.4.0/24;
    192.168.7.0/24;
};

// options clause defining the server-wide properties
options {
    // all relative paths use this directory as a base
    directory "/var";
    // version statement for security to avoid hacking known weaknesses
    // if the real version number is revealed
    version "not currently available";
    // this is the default
    recursion yes;
    // recursive queries only allowed from these ips
    // and references the acl clause
```

(continues on next page)

(continued from previous page)

```
allow-query { corpnets; };
// this ensures that any reverse map for private IPs
// not defined in a zone file will *not* be passed to the public network
// it is the default value
empty-zones-enable yes;
// this defines the addresses of the resolvers to which queries will be forwarded
forwarders {
    192.168.250.3;
    192.168.230.27;
};
// indicates all queries will be forwarded other than for defined zones
forward only;
};

// logging clause
// log to /var/log/named/example.log all events from info UP in severity (no debug)
// uses 3 files in rotation swaps files when size reaches 250K
// failure messages that occur before logging is established are
// in syslog (/var/log/messages)
//
logging {
    channel example_log {
        // uses a relative path name and the directory statement to
        // expand to /var/log/named/example.log
        file "log/named/example.log" versions 3 size 250k;
        // only log info and up messages - all others discarded
        severity info;
    };
    category default {
        example_log;
    };
};

// hints zone file is not required

// zone file for the localhost forward map
// discretionary zone depending on hosts file (see discussion)
zone "localhost" {
    type primary;
    file "masters/localhost-forward.db";
    notify no;
};

// zone file for the loopback address
// necessary zone
zone "0.0.127.in-addr.arpa" {
    type primary;
    file "localhost.rev";
    notify no;
};

// zone file for local IP reverse map
```

(continues on next page)

(continued from previous page)

```
// discretionary file depending on requirements
zone "254.168.192.in-addr.arpa" {
    type primary;
    file "192.168.254.rev";
    notify no;
};
```

The *zone* and *acl* blocks, and the *allow-query*, *empty-zones-enable*, *file*, *forward*, *forwarders*, *notify*, *recursion*, and *type* statements are described in detail in the appropriate sections.

As a reminder, the configuration of this forwarding resolver does **not** forward any recursive query for which:

1. The answer is already in the cache.
2. The domain name is **localhost** (zone localhost).
3. Is a reverse-map query for 127.0.0.1 (zone 0.0.127.in-addr.arpa).
4. Is a reverse-map query for 192.168.254/24 (zone 254.168.192.in-addr.arpa).
5. Is a reverse-map query for any local IP (*empty-zones-enable* statement).

All other recursive queries will be forwarded to resolve the query.

### 3.3.4 Selective Forwarding Resolver Configuration

This forwarding resolver configuration only forwards recursive queries for the zone **example.com** to the resolvers at 192.168.250.3 and 192.168.230.27. All other recursive queries, other than those for the defined zones and those for which the answer is already in its cache, are handled by this resolver. The forwarding resolver will cache all responses from both the public network and from the forwarded resolvers. The configuration is closed, in that it defines those IPs from which it will accept recursive queries.

```
// selective forwarding named.conf file
// Two corporate subnets we wish to allow queries from
// defined in an acl clause
acl corpnets {
    192.168.4.0/24;
    192.168.7.0/24;
};

// options clause defining the server-wide properties
options {
    // all relative paths use this directory as a base
    directory "/var";
    // version statement for security to avoid hacking known weaknesses
    // if the real version number is revealed
    version "not currently available";
    // this is the default
    recursion yes;
    // recursive queries only allowed from these ips
    // and references the acl clause
    allow-query { corpnets; };
    // this ensures that any reverse map for private IPs
    // not defined in a zone file will *not* be passed to the public network
    // it is the default value
    empty-zones-enable yes;
```

(continues on next page)

(continued from previous page)

```
// forwarding is not global but selective by zone in this configuration
};

// logging clause
// log to /var/log/named/example.log all events from info UP in severity (no debug)
// uses 3 files in rotation swaps files when size reaches 250K
// failure messages that occur before logging is established are
// in syslog (/var/log/messages)
//
logging {
    channel example_log {
        // uses a relative path name and the directory statement to
        // expand to /var/log/named/example.log
        file "log/named/example.log" versions 3 size 250k;
        // only log info and up messages - all others discarded
        severity info;
    };
    category default {
        example_log;
    };
};

// zone file for the root servers
// discretionary zone (see root server discussion above)
zone "." {
    type hint;
    file "named.root";
};

// zone file for the localhost forward map
// discretionary zone depending on hosts file (see discussion)
zone "localhost" {
    type primary;
    file "masters/localhost-forward.db";
    notify no;
};

// zone file for the loopback address
// necessary zone
zone "0.0.127.in-addr.arpa" {
    type primary;
    file "localhost.rev";
    notify no;
};

// zone file for local IP reverse map
// discretionary file depending on requirements
zone "254.168.192.in-addr.arpa" {
    type primary;
    file "192.168.254.rev";
    notify no;
};
```

(continues on next page)

(continued from previous page)

```

};
// zone file forwarded example.com
zone "example.com" {
    type forward;
    // this defines the addresses of the resolvers to
    // which queries for this zone will be forwarded
    forwarders {
        192.168.250.3;
        192.168.230.27;
    };
    // indicates all queries for this zone will be forwarded
    forward only;
};

```

The *zone* and *acl* blocks, and the *allow-query*, *empty-zones-enable*, *file*, *forward*, *forwarders*, *notify*, *recursion*, and *type* statements are described in detail in the appropriate sections.

As a reminder, the configuration of this resolver does **not** access the DNS hierarchy (does not use the public network) for any recursive query for which:

1. The answer is already in the cache.
2. The domain name is **localhost** (zone localhost).
3. Is a reverse-map query for 127.0.0.1 (zone 0.0.127.in-addr.arpa).
4. Is a reverse-map query for 192.168.254/24 (zone 254.168.192.in-addr.arpa).
5. Is a reverse-map query for any local IP (empty-zones-enable statement).
6. Is a query for the domain name **example.com**, in which case it will be forwarded to either 192.168.250.3 or 192.168.230.27 (zone example.com).

All other recursive queries will result in access to the DNS hierarchy to resolve the query.

## 3.4 Load Balancing

A primitive form of load balancing can be achieved in the DNS by using multiple resource records (RRs) in a *zone file* (such as multiple A records) for one name.

For example, assuming three HTTP servers with network addresses of 10.0.0.1, 10.0.0.2, and 10.0.0.3, a set of records such as the following means that clients will connect to each machine one-third of the time:

Name	TTL	CLASS	TYPE	Resource Record (RR) Data
www	600	IN	A	10.0.0.1
	600	IN	A	10.0.0.2
	600	IN	A	10.0.0.3

When a resolver queries for these records, BIND rotates them and responds to the query with the records in a random order. In the example above, clients randomly receive records in the order 1, 2, 3; 2, 3, 1; and 3, 1, 2. Most clients use the first record returned and discard the rest.

For more detail on ordering responses, refer to the *rrset-order* statement in the *options* block.

## 3.5 Zone File

This section, largely borrowed from [RFC 1034](#), describes the concept of a Resource Record (RR) and explains how to use them.

### 3.5.1 Resource Records

A domain name identifies a node in the DNS tree namespace. Each node has a set of resource information, which may be empty. The set of resource information associated with a particular name is composed of separate RRs. The order of RRs in a set is not significant and need not be preserved by name servers, resolvers, or other parts of the DNS. However, sorting of multiple RRs is permitted for optimization purposes: for example, to specify that a particular nearby server be tried first. See *sortlist* and *RRset Ordering*.

The components of a Resource Record are:

**owner name**

The domain name where the RR is found.

**RR type**

An encoded 16-bit value that specifies the type of the resource record. For a list of *types* of valid RRs, including those that have been obsoleted, please refer to <https://www.iana.org/assignments/dns-parameters/dns-parameters.xhtml#dns-parameters-4>.

**TTL**

The time-to-live of the RR. This field is a 32-bit integer in units of seconds, and is primarily used by resolvers when they cache RRs. The TTL describes how long a RR can be cached before it should be discarded.

**class**

An encoded 16-bit value that identifies a protocol family or an instance of a protocol.

**RDATA**

The resource data. The format of the data is type- and sometimes class-specific.

The following *classes* of resource records are currently valid in the DNS:

**IN**

The Internet. The only widely *class* used today.

**CH**

Chaosnet, a LAN protocol created at MIT in the mid-1970s. It was rarely used for its historical purpose, but was reused for BIND's built-in server information zones, e.g., **version.bind**.

**HS**

Hesiod, an information service developed by MIT's Project Athena. It was used to share information about various systems databases, such as users, groups, printers, etc.

The *owner name* is often implicit, rather than forming an integral part of the RR. For example, many name servers internally form tree or hash structures for the name space, and chain RRs off nodes. The remaining RR parts are the fixed header (type, class, TTL), which is consistent for all RRs, and a variable part (RDATA) that fits the needs of the resource being described.

The TTL field is a time limit on how long an RR can be kept in a cache. This limit does not apply to authoritative data in zones; that also times out, but follows the refreshing policies for the zone. The TTL is assigned by the administrator for the zone where the data originates. While short TTLs can be used to minimize caching, and a zero TTL prohibits caching, the realities of Internet performance suggest that these times should be on the order of days for the typical host. If a change is anticipated, the TTL can be reduced prior to the change to minimize inconsistency, and then increased back to its former value following the change.

The data in the RDATA section of RRs is carried as a combination of binary strings and domain names. The domain names are frequently used as "pointers" to other data in the DNS.

### Textual Expression of RRs

RRs are represented in binary form in the packets of the DNS protocol, and are usually represented in highly encoded form when stored in a name server or resolver. In the examples provided in [RFC 1034](#), a style similar to that used in primary files was employed in order to show the contents of RRs. In this format, most RRs are shown on a single line, although continuation lines are possible using parentheses.

The start of the line gives the owner of the RR. If a line begins with a blank, then the owner is assumed to be the same as that of the previous RR. Blank lines are often included for readability.

Following the owner are listed the TTL, type, and class of the RR. Class and type use the mnemonics defined above, and TTL is an integer before the type field. To avoid ambiguity in parsing, type and class mnemonics are disjoint, TTLs are integers, and the type mnemonic is always last. The IN class and TTL values are often omitted from examples in the interest of clarity.

The resource data or RDATA section of the RR is given using knowledge of the typical representation for the data.

For example, the RRs carried in a message might be shown as:

<b>ISI.EDU.</b>	<b>MX</b>	<b>10</b>	<b>VENERA.ISI.EDU.</b>
	<b>MX</b>	<b>10</b>	<b>VAXA.ISI.EDU</b>
<b>VENERA.ISI.EDU</b>	<b>A</b>	<b>128.9.0.32</b>	
	<b>A</b>	<b>10.1.0.52</b>	
<b>VAXA.ISI.EDU</b>	<b>A</b>	<b>10.2.0.27</b>	
	<b>A</b>	<b>128.9.0.33</b>	

The MX RRs have an RDATA section which consists of a 16-bit number followed by a domain name. The address RRs use a standard IP address format to contain a 32-bit Internet address.

The above example shows six RRs, with two RRs at each of three domain names.

Here is another possible example:

<b>XX.LCS.MIT.EDU.</b>	<b>IN A</b>	<b>10.0.0.44</b>
	<b>CH A</b>	<b>MIT.EDU. 2420</b>

This shows two addresses for **XX.LCS.MIT.EDU**, each of a different class.

### 3.5.2 Discussion of MX Records

As described above, domain servers store information as a series of resource records, each of which contains a particular piece of information about a given domain name (which is usually, but not always, a host). The simplest way to think of an RR is as a typed pair of data, a domain name matched with a relevant datum and stored with some additional type information, to help systems determine when the RR is relevant.

MX records are used to control delivery of email. The data specified in the record is a priority and a domain name. The priority controls the order in which email delivery is attempted, with the lowest number first. If two priorities are the same, a server is chosen randomly. If no servers at a given priority are responding, the mail transport agent falls back to the next largest priority. Priority numbers do not have any absolute meaning; they are relevant only relative to other MX records for that domain name. The domain name given is the machine to which the mail is delivered. It *must* have an associated address record (A or AAAA); CNAME is not sufficient.

For a given domain, if there is both a CNAME record and an MX record, the MX record is in error and is ignored. Instead, the mail is delivered to the server specified in the MX record pointed to by the CNAME. For example:

<b>example.com.</b>	<b>IN</b>	<b>MX</b>	<b>10</b>	<b>mail.example.com.</b>
				<b>mail2.example.com.</b>
			<b>20</b>	<b>mail.backup.org.</b>
<b>mail.example.com.</b>	<b>IN</b>	<b>A</b>	<b>10.0.0.1</b>	
<b>mail2.example.com.</b>	<b>IN</b>	<b>A</b>	<b>10.0.0.2</b>	

Mail delivery is attempted to **mail.example.com** and **mail2.example.com** (in any order); if neither of those succeeds, delivery to **mail.backup.org** is attempted.

### 3.5.3 Setting TTLs

The time-to-live (TTL) of the RR field is a 32-bit integer represented in units of seconds, and is primarily used by resolvers when they cache RRs. The TTL describes how long an RR can be cached before it should be discarded. The following three types of TTLs are currently used in a zone file.

#### SOA minimum

The last field in the SOA is the negative caching TTL. This controls how long other servers cache no-such-domain (NXDOMAIN) responses from this server. Further details can be found in [RFC 2308](#).

The maximum time for negative caching is 3 hours (3h).

#### \$TTL

The \$TTL directive at the top of the zone file (before the SOA) gives a default TTL for every RR without a specific TTL set.

#### RR TTLs

Each RR can have a TTL as the second field in the RR, which controls how long other servers can cache it.

All of these TTLs default to units of seconds, though units can be explicitly specified: for example, **1h30m**.

### 3.5.4 Inverse Mapping in IPv4

Reverse name resolution (that is, translation from IP address to name) is achieved by means of the **in-addr.arpa** domain and PTR records. Entries in the in-addr.arpa domain are made in least-to-most significant order, read left to right. This is the opposite order to the way IP addresses are usually written. Thus, a machine with an IP address of 10.1.2.3 would have a corresponding in-addr.arpa name of 3.2.1.10.in-addr.arpa. This name should have a PTR resource record whose data field is the name of the machine or, optionally, multiple PTR records if the machine has more than one name. For example, in the **example.com** domain:

<b>\$ORIGIN</b>	<b>2.1.10.in-addr.arpa</b>
<b>3</b>	<b>IN PTR foo.example.com.</b>

#### Note

The \$ORIGIN line in this example is only to provide context; it does not necessarily appear in the actual usage. It is only used here to indicate that the example is relative to the listed origin.

### 3.5.5 Other Zone File Directives

The DNS "master file" format was initially defined in [RFC 1035](#) and has subsequently been extended. While the format itself is class-independent, all records in a zone file must be of the same class.

Master file directives include \$ORIGIN, \$INCLUDE, and \$TTL.

## The @ (at-sign)

When used in the label (or name) field, the asperand or at-sign (@) symbol represents the current origin. At the start of the zone file, it is the `<zone_name>`, followed by a trailing dot (.).

## The \$ORIGIN Directive

Syntax: `$ORIGIN domain-name [comment]`

`$ORIGIN` sets the domain name that is appended to any unqualified records. When a zone is first read, there is an implicit `$ORIGIN <zone_name> .`; note the trailing dot. The current `$ORIGIN` is appended to the domain specified in the `$ORIGIN` argument if it is not absolute.

```
$ORIGIN example.com.
WWW      CNAME      MAIN-SERVER
```

is equivalent to

```
WWW.EXAMPLE.COM. CNAME MAIN-SERVER.EXAMPLE.COM.
```

## The \$INCLUDE Directive

Syntax: `$INCLUDE filename [origin] [comment]`

This reads and processes the file `filename` as if it were included in the file at this point. The `filename` can be an absolute path, or a relative path. In the latter case it is read from `named`'s working directory. If `origin` is specified, the file is processed with `$ORIGIN` set to that value; otherwise, the current `$ORIGIN` is used.

The origin and the current domain name revert to the values they had prior to the `$INCLUDE` once the file has been read.

### Note

**RFC 1035** specifies that the current origin should be restored after an `$INCLUDE`, but it is silent on whether the current domain name should also be restored. BIND 9 restores both of them. This could be construed as a deviation from **RFC 1035**, a feature, or both.

## The \$TTL Directive

Syntax: `$TTL default-ttl [comment]`

This sets the default Time-To-Live (TTL) for subsequent records with undefined TTLs. Valid TTLs are of the range 0-2147483647 seconds.

`$TTL` is defined in **RFC 2308**.

## 3.5.6 BIND Primary File Extension: the \$GENERATE Directive

Syntax: `$GENERATE range owner [ttl] [class] type rdata [comment]`

`$GENERATE` is used to create a series of resource records that only differ from each other by an iterator.

### range

This can be one of two forms: `start-stop` or `start-stop/step`. If the first form is used, then `step` is set to 1. "start", "stop", and "step" must be positive integers between 0 and  $(2^{31})-1$ . "start" must not be larger than "stop".

**owner**

This describes the owner name of the resource records to be created.

The **owner** string may include one or more \$ (dollar sign) symbols, which will be replaced with the iterator value when generating records; see below for details.

**ttl**

This specifies the time-to-live of the generated records. If not specified, this is inherited using the normal TTL inheritance rules.

**class** and **ttl** can be entered in either order.

**class**

This specifies the class of the generated records. This must match the zone class if it is specified.

**class** and **ttl** can be entered in either order.

**type**

This can be any valid type.

**rdata**

This is a string containing the RDATA of the resource record to be created. As with **owner**, the **rdata** string may include one or more \$ symbols, which are replaced with the iterator value. **rdata** may be quoted if there are spaces in the string; the quotation marks do not appear in the generated record.

Any single \$ (dollar sign) symbols within the **owner** or **rdata** strings are replaced by the iterator value. To get a \$ in the output, escape the \$ using a backslash \, e.g., \\$ . (For compatibility with earlier versions, \$\$ is also recognized as indicating a literal \$ in the output.)

The \$ may optionally be followed by modifiers which change the offset from the iterator, field width, and base. Modifiers are introduced by a { (left brace) immediately following the \$, as in **\${offset[,width[,base]]}**. For example, **-\${20,3,d}** subtracts 20 from the current value and prints the result as a decimal in a zero-padded field of width 3. Available output forms are decimal (**d**), octal (**o**), hexadecimal (**x** or **X** for uppercase), and nibble (**n** or **N** for uppercase). The modifier cannot contain whitespace or newlines.

The default modifier is **\${0,0,d}**. If the **owner** is not absolute, the current **\$ORIGIN** is appended to the name.

In nibble mode, the value is treated as if it were a reversed hexadecimal string, with each hexadecimal digit as a separate label. The width field includes the label separator.

Examples:

**\$GENERATE** can be used to easily generate the sets of records required to support sub-/24 reverse delegations described in [RFC 2317](#):

```
$ORIGIN 0.0.192.IN-ADDR.ARPA.
$GENERATE 1-2 @ NS SERVER$.EXAMPLE.
$GENERATE 1-127 $ CNAME $.0
```

is equivalent to

```
0.0.0.192.IN-ADDR.ARPA. NS SERVER1.EXAMPLE.
0.0.0.192.IN-ADDR.ARPA. NS SERVER2.EXAMPLE.
1.0.0.192.IN-ADDR.ARPA. CNAME 1.0.0.0.192.IN-ADDR.ARPA.
2.0.0.192.IN-ADDR.ARPA. CNAME 2.0.0.0.192.IN-ADDR.ARPA.
...
127.0.0.192.IN-ADDR.ARPA. CNAME 127.0.0.0.192.IN-ADDR.ARPA.
```

This example creates a set of A and MX records. Note the MX's **rdata** is a quoted string; the quotes are stripped when **\$GENERATE** is processed:

```
$ORIGIN EXAMPLE.
$GENERATE 1-127 HOST-$ A 1.2.3.$
$GENERATE 1-127 HOST-$ MX "0 ."
```

is equivalent to

```
HOST-1.EXAMPLE.  A  1.2.3.1
HOST-1.EXAMPLE.  MX 0 .
HOST-2.EXAMPLE.  A  1.2.3.2
HOST-2.EXAMPLE.  MX 0 .
HOST-3.EXAMPLE.  A  1.2.3.3
HOST-3.EXAMPLE.  MX 0 .
...
HOST-127.EXAMPLE. A  1.2.3.127
HOST-127.EXAMPLE. MX 0 .
```

This example generates A and AAAA records using modifiers; the AAAA **owner** names are generated using nibble mode:

```
$ORIGIN EXAMPLE.
$GENERATE 0-2 HOST-#{0,4,d} A 1.2.3.#{1,0,d}
$GENERATE 1024-1026 #{0,3,n} AAAA 2001:db8::#{0,4,x}
```

is equivalent to:

```
HOST-0000.EXAMPLE.  A      1.2.3.1
HOST-0001.EXAMPLE.  A      1.2.3.2
HOST-0002.EXAMPLE.  A      1.2.3.3
0.0.4.EXAMPLE.     AAAA   2001:db8::400
1.0.4.EXAMPLE.     AAAA   2001:db8::401
2.0.4.EXAMPLE.     AAAA   2001:db8::402
```

The **\$GENERATE** directive is a BIND extension and not part of the standard zone file format.

### 3.5.7 Additional File Formats

In addition to the standard text format, BIND 9 supports the ability to read or dump to zone files in other formats.

The **raw** format is a binary representation of zone data in a manner similar to that used in zone transfers. Since it does not require parsing text, load time is significantly reduced.

For a primary server, a zone file in **raw** format is expected to be generated from a text zone file by the `named-compilezone` command. For a secondary server or a dynamic zone, the zone file is automatically generated when `named` dumps the zone contents after zone transfer or when applying prior updates, if one of these formats is specified by the **masterfile-format** option.

If a zone file in **raw** format needs manual modification, it first must be converted to **text** format by the `named-compilezone` command, then converted back after editing. For example:

```
named-compilezone -f raw -F text -o zonefile.text <origin> zonefile.raw
[edit zonefile.text]
named-compilezone -f text -F raw -o zonefile.raw <origin> zonefile.text
```



## NAME SERVER OPERATIONS

### 4.1 Tools for Use With the Name Server Daemon

This section describes several indispensable diagnostic, administrative, and monitoring tools available to the system administrator for controlling and debugging the name server daemon.

#### 4.1.1 Diagnostic Tools

The *dig*, *host*, and *nslookup* programs are all command-line tools for manually querying name servers. They differ in style and output format.

##### *dig*

*dig* is the most versatile and complete of these lookup tools. It has two modes: simple interactive mode for a single query, and batch mode, which executes a query for each in a list of several query lines. All query options are accessible from the command line.

For more information and a list of available commands and options, see *dig - DNS lookup utility*.

##### *host*

The *host* utility emphasizes simplicity and ease of use. By default, it converts between host names and Internet addresses, but its functionality can be extended with the use of options.

For more information and a list of available commands and options, see *host - DNS lookup utility*.

##### *nslookup*

*nslookup* has two modes: interactive and non-interactive. Interactive mode allows the user to query name servers for information about various hosts and domains, or to print a list of hosts in a domain. Non-interactive mode is used to print just the name and requested information for a host or domain.

Due to its arcane user interface and frequently inconsistent behavior, we do not recommend the use of *nslookup*. Use *dig* instead.

#### 4.1.2 Administrative Tools

Administrative tools play an integral part in the management of a server.

##### *named-checkconf*

The *named-checkconf* program checks the syntax of a *named.conf* file.

For more information and a list of available commands and options, see *named-checkconf - named configuration file syntax checking tool*.

##### *named-checkzone*

The *named-checkzone* program checks a zone file for syntax and consistency.

For more information and a list of available commands and options, see *named-checkzone - zone file validation tool*.

***named-compilezone***

This tool is similar to *named-checkzone* but it always dumps the zone content to a specified file (typically in a different format).

For more information and a list of available commands and options, see *named-compilezone - zone file converting tool*.

***rndc***

The remote name daemon control (*rndc*) program allows the system administrator to control the operation of a name server.

See *rndc - name server control utility* for details of the available *rndc* commands.

*rndc* requires a configuration file, since all communication with the server is authenticated with digital signatures that rely on a shared secret, and there is no way to provide that secret other than with a configuration file. The default location for the *rndc* configuration file is `/usr/local/etc/rndc.conf`, but an alternate location can be specified with the `-c` option. If the configuration file is not found, *rndc* also looks in `/usr/local/etc/rndc.key` (or whatever `sysconfdir` was defined when the BIND build was configured). The `rndc.key` file is generated by running *rndc-confgen -a* as described in *controls*.

The format of the configuration file is similar to that of *named.conf*, but is limited to only three blocks: the *options*, *key*, *server*, and the *include Directive*. These blocks are what associate the secret keys to the servers with which they are meant to be shared. The order of blocks is not significant.

**options**

**Grammar:**

```
options {
    default-key <string>;
    default-port <integer>;
    default-server <string>;
    default-source-address ( <ipv4_address> | * );
    default-source-address-v6 ( <ipv6_address> | * );
};
```

**Blocks:** topmost

**default-server**

**Grammar:** `default-server <string>;`

**Blocks:** options

*default-server* takes a host name or address argument and represents the server that is contacted if no `-s` option is provided on the command line.

**default-key**

**Grammar:** `default-key <string>;`

**Blocks:** options

*default-key* takes the name of a key as its argument, as defined by a *key* block.

**default-port**

**Grammar:** `default-port <integer>;`

**Blocks:** options

*default-port* specifies the port to which *rndc* should connect if no port is given on the command line or in a *server* block.

**default-source-address**

**Grammar:** default-source-address ( <ipv4\_address> | \* );

**Blocks:** options

**default-source-address-v6**

**Grammar:** default-source-address-v6 ( <ipv6\_address> | \* );

**Blocks:** options

*default-source-address* and *default-source-address-v6* specify the IPv4 and IPv6 source address used to communicate with the server if no address is given on the command line or in a *server* block.

**key**

**Grammar server:** key <string>;

**Grammar topmost:**

```
key <string> {
    algorithm <string>;
    secret <string>;
}; // may occur multiple times
```

**Blocks:** topmost, server

The *key* block defines a key to be used by *rndc* when authenticating with *named*. Its syntax is identical to the *key* statement in *named.conf*. The keyword *key* is followed by a key name, which must be a valid domain name, though it need not actually be hierarchical; thus, a string like *rndc\_key* is a valid name. The *key* block has two statements: *algorithm* and *secret*.

**algorithm**

**Grammar:** algorithm <string>;

**Blocks:** key

While the configuration parser accepts any string as the argument to *algorithm*, currently only the strings *hmac-md5*, *hmac-sha1*, *hmac-sha224*, *hmac-sha256*, *hmac-sha384*, and *hmac-sha512* have any meaning.

**secret**

**Grammar:** secret <string>;

**Blocks:** key

The secret is a Base64-encoded string as specified in [RFC 3548](#).

**server**

**Grammar:**

```
server <string> {
    addresses { ( <quoted_string> [ port <integer> ] | <ipv4_address> [ port
↪<integer> ] | <ipv6_address> [ port <integer> ] ); ... };
    key <string>;
    port <integer>;
    source-address ( <ipv4_address> | * );
    source-address-v6 ( <ipv6_address> | * );
}; // may occur multiple times
```

**Blocks:** topmost

The *server* block specifies connection parameters for a given server. The server can be specified as a host name or address.

**addresses**

**Grammar:** `addresses { ( <quoted_string> [ port <integer> ] | <ipv4_address> [ port <integer> ] | <ipv6_address> [ port <integer> ] ); ... };`

**Blocks:** server

Specifies one or more addresses to use when communicating with this server.

**key**

Associates a key defined using the *key* statement with a server.

**port**

**Grammar:** `port <integer>;`

**Blocks:** server

Specifies the port *rndc* should connect to on the server.

**source-address**

**Grammar:** `source-address ( <ipv4_address> | * );`

**Blocks:** server

**source-address-v6**

**Grammar:** `source-address-v6 ( <ipv6_address> | * );`

**Blocks:** server

Overrides *default-source-address* and *default-source-address-v6* for this specific server.

A sample minimal configuration file is as follows:

```
key rndc_key {
    algorithm "hmac-sha256";
    secret
        "c3Ryb25nIGVub3VnaCBmb3IgYSBtYW4gYnV0IG1hZGUgZm9yIGEGd29tYW4K";
};
options {
    default-server 127.0.0.1;
    default-key    rndc_key;
};
```

This file, if installed as `/usr/local/etc/rndc.conf`, allows the command:

`rndc reload`

to connect to 127.0.0.1 port 953 and causes the name server to reload, if a name server on the local machine is running with the following controls statements:

```
controls {
    inet 127.0.0.1
        allow { localhost; } keys { rndc_key; };
};
```

and it has an identical key block for `rndc_key`.

Running the `rndc-confgen` program conveniently creates an `rndc.conf` file, and also displays the corresponding `controls` statement needed to add to `named.conf`. Alternatively, it is possible to run `rndc-confgen -a` to set up an `rndc.key` file and not modify `named.conf` at all.

## 4.2 Signals

Certain Unix signals cause the name server to take specific actions, as described in the following table. These signals can be sent using the `kill` command.

SIGHUP	Causes the server to read <code>named.conf</code> and reload the database.
SIGTERM	Causes the server to clean up and exit.
SIGINT	Causes the server to clean up and exit.

## 4.3 Plugins

Plugins are a mechanism to extend the functionality of `named` using dynamically loadable libraries. By using plugins, core server functionality can be kept simple for the majority of users; more complex code implementing optional features need only be installed by users that need those features.

The plugin interface is a work in progress, and is expected to evolve as more plugins are added. Currently, only "query plugins" are supported; these modify the name server query logic. Other plugin types may be added in the future.

The only plugin currently included in BIND is `filter-aaaa.so`, which replaces the `filter-aaaa` feature that previously existed natively as part of `named`. The code for this feature has been removed from `named` and can no longer be configured using standard `named.conf` syntax, but linking in the `filter-aaaa.so` plugin provides identical functionality.

## 4.4 Configuring Plugins

### plugin

**Grammar:** `plugin ( query ) <string> [ { <unspecified-text> } ];` // may occur multiple times

**Blocks:** `topmost`, `view`

**Tags:** `server`

Configures plugins in `named.conf`.

A plugin is configured with the `plugin` statement in `named.conf`:

```
plugin query "library.so" {
    parameters
};
```

In this example, file `library.so` is the plugin library. `query` indicates that this is a query plugin.

Multiple `plugin` statements can be specified, to load different plugins or multiple instances of the same plugin.

`parameters` are passed as an opaque string to the plugin's initialization routine. Configuration syntax differs depending on the module.

## 4.5 Developing Plugins

Each plugin implements four functions:

- `plugin_register` to allocate memory, configure a plugin instance, and attach to hook points within *named*,
- `plugin_destroy` to tear down the plugin instance and free memory,
- `plugin_version` to check that the plugin is compatible with the current version of the plugin API,
- `plugin_check` to test syntactic correctness of the plugin parameters.

At various locations within the *named* source code, there are "hook points" at which a plugin may register itself. When a hook point is reached while *named* is running, it is checked to see whether any plugins have registered themselves there; if so, the associated "hook action" - a function within the plugin library - is called. Hook actions may examine the runtime state and make changes: for example, modifying the answers to be sent back to a client or forcing a query to be aborted. More details can be found in the file `lib/ns/include/ns/hooks.h`.

DNS Security Extensions (DNSSEC) provide reliable protection from [cache poisoning](#) attacks. At the same time these extensions also provide other benefits: they limit the impact of [random subdomain attacks](#) on resolver caches and authoritative servers, and provide the foundation for modern applications like [authenticated and private e-mail transfer](#).

To achieve this goal, DNSSEC adds [digital signatures](#) to DNS records in authoritative DNS zones, and DNS resolvers verify the validity of the signatures on the received records. If the signatures match the received data, the resolver can be sure that the data was not modified in transit.

**Note**

DNSSEC and transport-level encryption are complementary! Unlike typical transport-level encryption like DNS-over-TLS, DNS-over-HTTPS, or VPN, DNSSEC makes DNS records verifiable at all points of the DNS resolution chain.

This section focuses on ways to deploy DNSSEC using BIND. For a more in-depth discussion of DNSSEC principles (e.g. *How Does DNSSEC Change DNS Lookup?*) please see *DNSSEC Guide*.

## 5.1 Zone Signing

BIND offers several ways to generate signatures and maintain their validity during the lifetime of a DNS zone:

- *Fully Automated (Key and Signing Policy)* - **strongly recommended**
- *Manual Key Management* - only for special needs
- *Manual Signing* - discouraged, use only for debugging

### 5.1.1 Zone keys

Regardless of the *zone-signing* method in use, cryptographic keys are stored in files named like `Kdnssec.example.+013+12345.key` and `Kdnssec.example.+013+12345.private`. The private key (in the `.private` file) is used to generate signatures, and the public key (in the `.key` file) is used for signature verification. Additionally, the *Fully Automated (Key and Signing Policy)* method creates a third file, `Kdnssec.example+013+12345.state`, which is used to track DNSSEC key timings and to perform key rollovers safely.

These filenames contain:

- the key name, which always matches the zone name (`dnssec.example.`),
- the [algorithm number](#) (013 is ECDSAP256SHA256, 008 is RSASHA256, etc.),
- and the key tag, i.e. a non-unique key identifier (12345 in this case).

**Warning**

Private keys are required for full disaster recovery. Back up key files in a safe location and protect them from unauthorized access. Anyone with access to the private key can create fake but seemingly valid DNS data.

## 5.1.2 Fully Automated (Key and Signing Policy)

Key and Signing Policy (KASP) is a method of configuration that describes how to maintain DNSSEC signing keys and how to sign the zone.

This is the recommended, fully automated way to sign and maintain DNS zones. For most use cases users can simply use the built-in default policy, which applies up-to-date DNSSEC practices:

```
zone "dnssec.example" {
    type primary;
    file "dnssec.example.db";
    dnssec-policy default;
    inline-signing yes;
};
```

The `dnssec-policy` statement requires dynamic DNS to be set up, or `inline-signing` to be enabled. In the example above we use the latter.

This is sufficient to create the necessary signing keys, and generate DNSKEY, RRSIG, and NSEC records for the zone. BIND also takes care of any DNSSEC maintenance for this zone, including replacing signatures that are about to expire and managing *Key Rollovers*.

**Note**

`dnssec-policy` needs write access to the zone. Please see `dnssec-policy` for more details about implications for zone storage.

The default policy creates one key that is used to sign the complete zone, and uses NSEC to enable authenticated denial of existence (a secure way to tell which records do not exist in a zone). This policy is recommended and typically does not need to be changed.

If needed, a custom policy can be defined by adding a `dnssec-policy` statement into the configuration:

```
dnssec-policy "custom" {
    dnskey-ttl 600;
    keys {
        ksk lifetime P1Y algorithm ecdsap384sha384;
        zsk lifetime 60d algorithm ecdsap384sha384;
    };
    nsec3param iterations 0 optout no salt-length 0;
};
```

This custom policy, for example:

- uses a very short DNSKEY TTL (600 seconds),
- uses two keys to sign the zone: a Key Signing Key (KSK) to sign the key related RRsets (DNSKEY, CDS, and CDNSKEY), and a Zone Signing Key (ZSK) to sign the rest of the zone. The KSK is automatically rotated after one year and the ZSK after 60 days.

**Also:**

- The configured keys have a lifetime set and use the ECDSAP384SHA384 algorithm.
- The last line instructs BIND to generate NSEC3 records for *Proof of Non-Existence*, using zero extra iterations and no salt. NSEC3 opt-out is disabled, meaning insecure delegations also get an NSEC3 record.

For more information about KASP configuration see [dnssec-policy](#).

The [Advanced Discussions](#) section in the DNSSEC Guide discusses the various policy settings and may be useful for determining values for specific needs.

**Key Rollover**

When using a [dnssec-policy](#), a key lifetime can be set to trigger key rollovers. ZSK rollovers are fully automatic, but for KSK and CSK rollovers a DS record needs to be submitted to the parent. See [Secure Delegation](#) for possible ways to do so.

Once the DS is in the parent (and the DS of the predecessor key is withdrawn), BIND needs to be told that this event has happened. This can be done automatically by configuring parental agents:

```
zone "dnssec.example" {
    type primary;
    file "dnssec.example.db";
    dnssec-policy default;
    inline-signing yes;
    parental-agents { 192.0.2.1; };
};
```

Here one server, 192.0.2.1, is configured for BIND to send DS queries to, to check the DS RRset for `dnssec-example` during key rollovers. This needs to be a trusted server, because BIND does not validate the response.

If setting up a parental agent is undesirable, it is also possible to tell BIND that the DS is published in the parent with: `rndc dnssec -checkds -key 12345 published dnssec.example..` and the DS for the predecessor key has been removed with: `rndc dnssec -checkds -key 54321 withdrawn dnssec.example..` where 12345 and 54321 are the key tags of the successor and predecessor key, respectively.

To roll a key sooner than scheduled, or to roll a key that has an unlimited lifetime, use: `rndc dnssec -rollover -key 12345 dnssec.example..`

You can pregenerate keys and save them in the key directory. As long as the key has no timing metadata set, it may be selected as a successor in the upcoming key rollover. To pregenerate keys without setting key timing metadata, use the `-G` option: `dnssec-keygen -G dnssec.example..`

To revert a signed zone back to an insecure zone, change the zone configuration to use the built-in "insecure" policy. Detailed instructions are described in [Reverting to Unsigned](#).

**5.1.3 Manual Key Management****Warning**

The method described here allows full control over the keys used to sign the zone. This is required only for very special cases and is generally discouraged. Under normal circumstances, please use [Fully Automated \(Key and Signing Policy\)](#).

**Multi-Signer Model**

Dynamic zones provide the ability to sign a zone by multiple providers, meaning each provider signs and serves the same zone independently. Such a setup requires some coordination between providers when it comes to key rollovers, and

may be better suited to be configured with `auto-dnssec allow;`. This permits keys to be updated and the zone to be re-signed only if the user issues the command `rndc sign zonename`.

A zone can also be configured with `auto-dnssec maintain`, which automatically adjusts the zone's DNSSEC keys on a schedule according to the key timing metadata. However, keys still need to be generated separately, for example with `dnssec-keygen`.

Of course, dynamic zones can also use `dnssec-policy` to fully automate DNSSEC maintenance. The next sections assume that more key management control is needed, and describe how to use dynamic DNS update to perform various DNSSEC operations.

### Enabling DNSSEC Manually

As an alternative to fully automated zone signing using `dnssec-policy`, a zone can be changed from insecure to secure using a dynamic DNS update. `named` must be configured so that it can see the `κ*` files which contain the public and private parts of the `zone keys` that are used to sign the zone. Key files should be placed in the `key-directory`, as specified in `named.conf`:

```
zone update.example {
    type primary;
    update-policy local;
    auto-dnssec allow;
    file "dynamic/update.example.db";
    key-directory "keys/update.example/";
};
```

If there are both a KSK and a ZSK available (or a CSK), this configuration causes the zone to be signed. An NSEC chain is generated as part of the initial signing process.

In any secure zone which supports dynamic updates, `named` periodically re-signs RRsets which have not been re-signed as a result of some update action. The signature lifetimes are adjusted to spread the re-sign load over time rather than all at once.

### Publishing DNSKEY Records

To insert the keys via dynamic update:

```
% nsupdate
> ttl 3600
> update add update.example DNSKEY 256 3 7_
↪AwEAAZn17pUF0KpbPA2c7Gz76Vb18v0teKT3EyAGfBfL8eQ8a135zz3Y I1m/
↪SAQBxIqMfLtIwqWPdgthsu36azGQAX8=
> update add update.example DNSKEY 257 3 7 AwEAAAd/7odU/
↪64o2LGsifbLtQmtO8dFDtTAZXSX2+X3e/UNlq9IHq3Y0 XtC0Iuawl/qkaKVxXe21o8Ct+dM6UehyCqk=
> send
```

In order to sign with these keys, the corresponding key files should also be placed in the `key-directory`.

### NSEC3

To sign using `NSEC3` instead of `NSEC`, add an NSEC3PARAM record to the initial update request. The `OPTOUT` bit in the NSEC3 chain can be set in the flags field of the NSEC3PARAM record.

```
% nsupdate
> ttl 3600
> update add update.example DNSKEY 256 3 7_
```

(continues on next page)

(continued from previous page)

```

↪AwEAAZn17pUF0KpbPA2c7Gz76Vb18v0teKT3EyAGfBfL8eQ8a135zz3Y I1m/
↪SAQBxIqMfLtIwqWpdgthsu36azGQAX8=
> update add update.example DNSKEY 257 3 7 AwEAAAd/7odU/
↪64o2LGsifbLtQmtO8dFDtTAZXSX2+X3e/UN1q9IHq3Y0 XtC0Iuawl/qkaKVxXe21o8Ct+dM6UehyCqk=
> update add update.example NSEC3PARAM 1 0 0 -
> send

```

Note that the `NSEC3PARAM` record does not show up until `named` has had a chance to build/remove the relevant chain. A private type record is created to record the state of the operation (see below for more details), and is removed once the operation completes.

The `NSEC3` chain is generated and the `NSEC3PARAM` record is added before the `NSEC` chain is destroyed.

While the initial signing and `NSEC/NSEC3` chain generation are occurring, other updates are possible as well.

A new `NSEC3PARAM` record can be added via dynamic update. When the new `NSEC3` chain has been generated, the `NSEC3PARAM` flag field is set to zero. At that point, the old `NSEC3PARAM` record can be removed. The old chain is removed after the update request completes.

`named` only supports creating new `NSEC3` chains where all the `NSEC3` records in the zone have the same `OPTOUT` state. `named` supports updates to zones where the `NSEC3` records in the chain have mixed `OPTOUT` state. `named` does not support changing the `OPTOUT` state of an individual `NSEC3` record; if the `OPTOUT` state of an individual `NSEC3` needs to be changed, the entire chain must be changed.

To switch back to `NSEC`, use `nsupdate` to remove any `NSEC3PARAM` records. The `NSEC` chain is generated before the `NSEC3` chain is removed.

## DNSKEY Rollovers

To perform key rollovers via a dynamic update, the `K*` files for the new keys must be added so that `named` can find them. The new `DNSKEY` RRs can then be added via dynamic update. When the zones are being signed, they are signed with the new key set; when the signing is complete, the private type records are updated so that the last octet is non-zero.

If this is for a `KSK`, the parent and any trust anchor repositories of the new `KSK` must be informed.

The maximum TTL in the zone must expire before removing the old `DNSKEY`. If it is a `KSK` that is being updated, the `DS` RRset in the parent must also be updated and its TTL allowed to expire. This ensures that all clients are able to verify at least one signature when the old `DNSKEY` is removed.

The old `DNSKEY` can be removed via `UPDATE`, taking care to specify the correct key. `named` cleans out any signatures generated by the old key after the update completes.

## Going Insecure

To convert a signed zone to unsigned using dynamic DNS, delete all the `DNSKEY` records from the zone apex using `nsupdate`. All signatures, `NSEC` or `NSEC3` chains, and associated `NSEC3PARAM` records are removed automatically when the zone is supposed to be re-signed.

This requires the `dnssec-secure-to-insecure` option to be set to `yes` in `named.conf`.

In addition, if the `auto-dnssec` maintain or a `dnssec-policy` is used, it should be removed or changed to allow instead; otherwise it will re-sign.

## 5.1.4 Manual Signing

There are several tools available to manually sign a zone.

### Warning

Please note manual procedures are available mainly for backwards compatibility and should be used only by expert users with specific needs.

To set up a DNSSEC secure zone manually, a series of steps must be followed. Please see chapter *Manual Signing* in the *DNSSEC Guide* for more information.

## 5.1.5 Monitoring with Private Type Records

The state of the signing process is signaled by private type records (with a default type value of 65534). When signing is complete, those records with a non-zero initial octet have a non-zero value for the final octet.

If the first octet of a private type record is non-zero, the record indicates either that the zone needs to be signed with the key matching the record, or that all signatures that match the record should be removed. Here are the meanings of the different values of the first octet:

- algorithm (octet 1)
- key ID in network order (octet 2 and 3)
- removal flag (octet 4)
- complete flag (octet 5)

Only records flagged as "complete" can be removed via dynamic update; attempts to remove other private type records are silently ignored.

If the first octet is zero (this is a reserved algorithm number that should never appear in a `DNSKEY` record), the record indicates that changes to the `NSEC3` chains are in progress. The rest of the record contains an `NSEC3PARAM` record, while the flag field tells what operation to perform based on the flag bits:

```
0x01 OPTOUT
0x80 CREATE
0x40 REMOVE
0x20 NONSEC
```

## 5.2 Secure Delegation

Once a zone is signed on the authoritative servers, the last remaining step is to establish chain of trust<sup>1</sup> between the parent zone (`example.`) and the local zone (`dnssec.example.`).

Generally the procedure is:

- **Wait** for stale data to expire from caches. The amount of time required is equal to the maximum TTL value used in the zone before signing. This step ensures that unsigned data expire from caches and resolvers do not get confused by missing signatures.
- Insert/update DS records in the parent zone (`dnssec.example.` DS record).

<sup>1</sup> For further details on how the chain of trust is used in practice, see *The 12-Step DNSSEC Validation Process (Simplified)* in the *DNSSEC Guide*.

There are multiple ways to update DS records in the parent zone. Refer to the documentation for the parent zone to find out which options are applicable to a given case zone. Generally the options are, from most- to least-recommended:

- Automatically update the DS record in the parent zone using CDS/CDNSKEY records automatically generated by BIND. This requires support for [RFC 7344](#) in either parent zone, registry, or registrar. In that case, configure BIND to *monitor DS records in the parent zone* and everything will happen automatically at the right time.
- Query the zone for automatically generated CDS or CDNSKEY records using *dig*, and then insert these records into the parent zone using the method specified by the parent zone (web form, e-mail, API, ...).
- Generate DS records manually using the *dnssec-dsfromkey* utility on *zone keys*, and then insert them into the parent zone.

## 5.3 DNSSEC Validation

The BIND resolver validates answers from authoritative servers by default. This behavior is controlled by the configuration statement *dnssec-validation*.

By default a trust anchor for the DNS root zone is used. This trust anchor is provided as part of BIND and is kept up-to-date using *Dynamic Trust Anchor Management*.

### Note

DNSSEC validation works "out of the box" and does not require additional configuration. Additional configuration options are intended only for special cases.

To validate answers, the resolver needs at least one trusted starting point, a "trust anchor." Essentially, trust anchors are copies of DNSKEY RRs for zones that are used to form the first link in the cryptographic chain of trust. Alternative trust anchors can be specified using *trust-anchors*, but this setup is very unusual and is recommended only for expert use. For more information, see *Trust Anchors* in the *DNSSEC Guide*.

The BIND authoritative server does not verify signatures on load, so zone keys for authoritative zones do not need to be specified in the configuration file.

### 5.3.1 Validation Failures

When DNSSEC validation is configured, the resolver rejects any answers from signed, secure zones which fail to validate, and returns SERVFAIL to the client.

Responses may fail to validate for any of several reasons, including missing, expired, or invalid signatures; a key which does not match the DS RRset in the parent zone; or an insecure response from a zone which, according to its parent, should have been secure.

For more information see *Basic DNSSEC Troubleshooting*.

### 5.3.2 Coexistence With Unsigned (Insecure) Zones

Zones not protected by DNSSEC are called "insecure," and these zones seamlessly coexist with signed zones.

When the validator receives a response from an unsigned zone that has a signed parent, it must confirm with the parent that the zone was intentionally left unsigned. It does this by verifying, via signed and validated *NSEC/NSEC3 records*, that the parent zone contains no DS records for the child.

If the validator *can* prove that the zone is insecure, then the response is accepted. However, if it cannot, the validator must assume an insecure response to be a forgery; it rejects the response and logs an error.

The logged error reads "insecurity proof failed" and "got insecure response; parent indicates it should be secure."

## 5.4 Dynamic Trust Anchor Management

BIND is able to maintain DNSSEC trust anchors using **RFC 5011** key management. This feature allows *named* to keep track of changes to critical DNSSEC keys without any need for the operator to make changes to configuration files.

### 5.4.1 Validating Resolver

To configure a validating resolver to use **RFC 5011** to maintain a trust anchor, configure the trust anchor using a *trust-anchors* statement and the *initial-key* keyword. Information about this can be found in the *trust-anchors* statement description.

### 5.4.2 Authoritative Server

To set up an authoritative zone for **RFC 5011** trust anchor maintenance, generate two (or more) key signing keys (KSKs) for the zone. Sign the zone with one of them; this is the "active" KSK. All KSKs which do not sign the zone are "stand-by" keys.

Any validating resolver which is configured to use the active KSK as an **RFC 5011**-managed trust anchor takes note of the stand-by KSKs in the zone's DNSKEY RRset, and stores them for future reference. The resolver rechecks the zone periodically; after 30 days, if the new key is still there, the key is accepted by the resolver as a valid trust anchor for the zone. Anytime after this 30-day acceptance timer has completed, the active KSK can be revoked, and the zone can be "rolled over" to the newly accepted key.

The easiest way to place a stand-by key in a zone is to use the "smart signing" features of *dnssec-keygen* and *dnssec-signzone*. If a key exists with a publication date in the past, but an activation date which is unset or in the future, *dnssec-signzone -S* includes the DNSKEY record in the zone but does not sign with it:

```
$ dnssec-keygen -K keys -f KSK -P now -A now+2y example.net
$ dnssec-signzone -S -K keys example.net
```

To revoke a key, use the command *dnssec-revoke*. This adds the REVOKED bit to the key flags and regenerates the *K\*.key* and *K\*.private* files.

After revoking the active key, the zone must be signed with both the revoked KSK and the new active KSK. Smart signing takes care of this automatically.

Once a key has been revoked and used to sign the DNSKEY RRset in which it appears, that key is never again accepted as a valid trust anchor by the resolver. However, validation can proceed using the new active key, which was accepted by the resolver when it was a stand-by key.

See **RFC 5011** for more details on key rollover scenarios.

When a key has been revoked, its key ID changes, increasing by 128 and wrapping around at 65535. So, for example, the key "Kexample.com.+005+10000" becomes "Kexample.com.+005+10128".

If two keys have IDs exactly 128 apart and one is revoked, the two key IDs will collide, causing several problems. To prevent this, *dnssec-keygen* does not generate a new key if another key which may collide is present. This checking only occurs if the new keys are written to the same directory that holds all other keys in use for that zone.

Older versions of BIND 9 did not have this protection. Exercise caution if using key revocation on keys that were generated by previous releases, or if using keys stored in multiple directories or on multiple machines.

It is expected that a future release of BIND 9 will address this problem in a different way, by storing revoked keys with their original unrevoked key IDs.

## 5.5 PKCS#11 (Cryptoki) Support

Public Key Cryptography Standard #11 (PKCS#11) defines a platform-independent API for the control of hardware security modules (HSMs) and other cryptographic support devices.

PKCS#11 uses a "provider library": a dynamically loadable library which provides a low-level PKCS#11 interface to drive the HSM hardware. The PKCS#11 provider library comes from the HSM vendor, and it is specific to the HSM to be controlled.

BIND 9 uses `engine_pkcs11` for PKCS#11. `engine_pkcs11` is an OpenSSL engine which is part of the [OpenSC](#) project. The engine is dynamically loaded into OpenSSL and the HSM is operated indirectly; any cryptographic operations not supported by the HSM can be carried out by OpenSSL instead.

### 5.5.1 Prerequisites

See the documentation provided by the HSM vendor for information about installing, initializing, testing, and troubleshooting the HSM.

### 5.5.2 Building SoftHSMv2

SoftHSMv2, the latest development version of SoftHSM, is available from <https://github.com/softhsm/SoftHSMv2>. It is a software library developed by the OpenDNSSEC project (<https://www.opendnssec.org>) which provides a PKCS#11 interface to a virtual HSM, implemented in the form of an SQLite3 database on the local filesystem. It provides less security than a true HSM, but it allows users to experiment with native PKCS#11 when an HSM is not available. SoftHSMv2 can be configured to use either OpenSSL or the Botan library to perform cryptographic functions, but when using it for native PKCS#11 in BIND, OpenSSL is required.

By default, the SoftHSMv2 configuration file is `prefix/etc/softhsm2.conf` (where `prefix` is configured at compile time). This location can be overridden by the `SOFTHSM2_CONF` environment variable. The SoftHSMv2 cryptographic store must be installed and initialized before using it with BIND.

```
$ cd SoftHSMv2
$ configure --with-crypto-backend=openssl --prefix=/opt/pkcs11/usr
$ make
$ make install
$ /opt/pkcs11/usr/bin/softhsm-util --init-token 0 --slot 0 --label softhsmv2
```

### 5.5.3 OpenSSL-based PKCS#11

OpenSSL-based PKCS#11 uses `engine_pkcs11` OpenSSL engine from `libp11` project.

`engine_pkcs11` tries to fit the PKCS#11 API within the engine API of OpenSSL. That is, it provides a gateway between PKCS#11 modules and the OpenSSL engine API. One has to register the engine with OpenSSL and one has to provide the path to the PKCS#11 module which should be gatewayed to. This can be done by editing the OpenSSL configuration file, by engine specific controls, or by using the `p11-kit` proxy module.

It is recommended, that `libp11 >= 0.4.12` is used.

For more detailed howto including the examples, we recommend reading:

<https://gitlab.isc.org/isc-projects/bind9/-/wikis/BIND-9-PKCS11>

### 5.5.4 Using the HSM

The canonical documentation for configuring `engine_pkcs11` is in the `libp11/README.md` file, but a sample working configuration is included here for the user's convenience:

We are going to use our own custom copy of OpenSSL configuration, again it's driven by an environment variable, this time called `OPENSSL_CONF`. We are going to copy the global OpenSSL configuration (often found in `etc/ssl/openssl.cnf`) and customize it to use `engines_pkcs11`.

```
cp /etc/ssl/openssl.cnf /opt/bind9/etc/openssl.cnf
```

and export the environment variable:

```
export OPENSSL_CONF=/opt/bind9/etc/openssl.cnf
```

Now add following line at the top of file, before any sections (in square brackets) are defined:

```
openssl_conf = openssl_init
```

And make sure there are no other `'openssl_conf = ...'` lines in the file.

Add following lines at the bottom of the file:

```
[openssl_init]
engines=engine_section

[engine_section]
pkcs11 = pkcs11_section

[pkcs11_section]
engine_id = pkcs11
dynamic_path = <PATHTO>/pkcs11.so
MODULE_PATH = <FULL_PATH_TO_HSM_MODULE>
init = 0
```

## 5.5.5 Key Generation

HSM keys can now be created and used. We are assuming that BIND 9 is already installed, either from a package or from the sources, and the tools are readily available in the `$PATH`.

For generating the keys, we are going to use `pkcs11-tool` available from the OpenSC suite. On both DEB-based and RPM-based distributions, the package is called `opensc`.

We need to generate at least two RSA keys:

```
pkcs11-tool --module <FULL_PATH_TO_HSM_MODULE> -l -k --key-type rsa:2048 --label_
↪example.net-ksk --pin <PIN>
pkcs11-tool --module <FULL_PATH_TO_HSM_MODULE> -l -k --key-type rsa:2048 --label_
↪example.net-zsk --pin <PIN>
```

Remember that each key should have unique label and we are going to use that label to reference the private key.

Convert the RSA keys stored in the HSM into a format that BIND 9 understands. The `dnssec-keyfromlabel` tool from BIND 9 can link the raw keys stored in the HSM with the `K<zone>+<alg>+<id>` files. The OpenSSL engine name (`pkcs11`), the algorithm (`RSASHA256`) and the PKCS#11 label that specify the token (we assume that it has been initialized as `bind9`), the name of the PKCS#11 object (called "label" when generating the keys using `pkcs11-tool`), and the HSM PIN must all be provided.

Convert the KSK:

```
dnssec-keyfromlabel -E pkcs11 -a RSASHA256 -l "token=bind9;object=example.net-ksk;pin-
↪value=0000" -f KSK example.net
```

and ZSK:

```
dnssec-keyfromlabel -E pkcs11 -a RSASHA256 -l "token=bind9;object=example.net-zsk;pin-
↪value=0000" example.net
```

NOTE: a PIN stored on disk can be used by specifying `pin-source=<path_to>/<file>`, e.g:

```
(umask 0700 && echo -n 0000 > /opt/bind9/etc/pin.txt)
```

and then use in the label specification:

```
pin-source=/opt/bind9/etc/pin.txt
```

Confirm that there is one KSK and one ZSK present in the current directory:

```
ls -l K*
```

The output should look like this (the second number will be different):

```
Kexample.net.+008+31729.key
Kexample.net.+008+31729.private
Kexample.net.+008+42231.key
Kexample.net.+008+42231.private
```

A note on generating ECDSA keys: there is a bug in `libp11` when looking up a key. That function compares keys only on their ID, not the label, so when looking up a key it returns the first key, rather than the matching key. To work around this when creating ECDSA keys, specify a unique ID:

```
ksk=$(echo "example.net-ksk" | openssl sha1 -r | awk '{print $1}')
zsk=$(echo "example.net-zsk" | openssl sha1 -r | awk '{print $1}')
pkcs11-tool --module <FULL_PATH_TO_HSM_MODULE> -l -k --key-type EC:prime256v1 --id
↪$ksk --label example.net-ksk --pin <PIN>
pkcs11-tool --module <FULL_PATH_TO_HSM_MODULE> -l -k --key-type EC:prime256v1 --id
↪$zsk --label example.net-zsk --pin <PIN>
```

## 5.5.6 Specifying the Engine on the Command Line

When using OpenSSL-based PKCS#11, the "engine" to be used by OpenSSL can be specified in *named* and all of the BIND `dnssec-*` tools by using the `-E <engine>` command line option. Specifying the engine is generally not necessary unless a different OpenSSL engine is used.

The zone signing commences as usual, with only one small difference. We need to provide the name of the OpenSSL engine using the `-E` command line option.

```
dnssec-signzone -E pkcs11 -S -o example.net example.net
```

## 5.5.7 Running *named* With Automatic Zone Re-signing

The zone can also be signed automatically by *named*. Again, we need to provide the name of the OpenSSL engine using the `-E` command line option.

```
named -E pkcs11 -c named.conf
```

and the logs should have lines like:

```
Fetching example.net/RSASHA256/31729 (KSK) from key repository.
DNSKEY example.net/RSASHA256/31729 (KSK) is now published
DNSKEY example.net/RSA256SHA256/31729 (KSK) is now active
Fetching example.net/RSASHA256/42231 (ZSK) from key repository.
DNSKEY example.net/RSASHA256/42231 (ZSK) is now published
DNSKEY example.net/RSA256SHA256/42231 (ZSK) is now active
```

For *named* to dynamically re-sign zones using HSM keys, and/or to sign new records inserted via *nsupdate*, *named* must have access to the HSM PIN. In OpenSSL-based PKCS#11, this is accomplished by placing the PIN into the `openssl.cnf` file (in the above examples, `/opt/pkcs11/usr/ssl/openssl.cnf`).

The location of the `openssl.cnf` file can be overridden by setting the `OPENSSL_CONF` environment variable before running *named*.

Here is a sample `openssl.cnf`:

```
openssl_conf = openssl_def
[ openssl_def ]
engines = engine_section
[ engine_section ]
pkcs11 = pkcs11_section
[ pkcs11_section ]
PIN = <PLACE PIN HERE>
```

This also allows the `dnssec-*` tools to access the HSM without PIN entry. (The `pkcs11-*` tools access the HSM directly, not via OpenSSL, so a PIN is still required to use them.)

## ADVANCED CONFIGURATIONS

### 6.1 Dynamic Update

Dynamic update is a method for adding, replacing, or deleting records in a primary server by sending it a special form of DNS messages. The format and meaning of these messages is specified in [RFC 2136](#).

Dynamic update is enabled by including an *allow-update* or an *update-policy* clause in the *zone* statement.

If the zone's *update-policy* is set to *local*, updates to the zone are permitted for the key *local-ddns*, which is generated by *named* at startup. See *Dynamic Update Policies* for more details.

Dynamic updates using Kerberos-signed requests can be made using the TKEY/GSS protocol, by setting the *tkey-gssapi-keytab* option. Once enabled, Kerberos-signed requests are matched against the update policies for the zone, using the Kerberos principal as the signer for the request.

Updating of secure zones (zones using DNSSEC) follows [RFC 3007](#): RRSIG, NSEC, and NSEC3 records affected by updates are automatically regenerated by the server using an online zone key. Update authorization is based on transaction signatures and an explicit server policy.

#### 6.1.1 The Journal File

All changes made to a zone using dynamic update are stored in the zone's journal file. This file is automatically created by the server when the first dynamic update takes place. The name of the journal file is formed by appending the extension *.jnl* to the name of the corresponding zone file unless specifically overridden. The journal file is in a binary format and should not be edited manually.

The server also occasionally writes ("dumps") the complete contents of the updated zone to its zone file. This is not done immediately after each dynamic update because that would be too slow when a large zone is updated frequently. Instead, the dump is delayed by up to 15 minutes, allowing additional updates to take place. During the dump process, transient files are created with the extensions *.jnw* and *.jnk*; under ordinary circumstances, these are removed when the dump is complete, and can be safely ignored.

When a server is restarted after a shutdown or crash, it replays the journal file to incorporate into the zone any updates that took place after the last zone dump.

Changes that result from incoming incremental zone transfers are also journaled in a similar way.

The zone files of dynamic zones cannot normally be edited by hand because they are not guaranteed to contain the most recent dynamic changes; those are only in the journal file. The only way to ensure that the zone file of a dynamic zone is up-to-date is to run *rndc stop*.

To make changes to a dynamic zone manually, follow these steps: first, disable dynamic updates to the zone using *rndc freeze zone*. This updates the zone file with the changes stored in its *.jnl* file. Then, edit the zone file. Finally, run *rndc thaw zone* to reload the changed zone and re-enable dynamic updates.

*rndc sync zone* updates the zone file with changes from the journal file without stopping dynamic updates; this may be useful for viewing the current zone state. To remove the *.jnl* file after updating the zone file, use *rndc sync -clean*.

## 6.2 NOTIFY

DNS NOTIFY is a mechanism that allows primary servers to notify their secondary servers of changes to a zone's data. In response to a NOTIFY message from a primary server, the secondary checks to see that its version of the zone is the current version and, if not, initiates a zone transfer.

For more information about DNS NOTIFY, see the description of the *notify* and *also-notify* statements. The NOTIFY protocol is specified in [RFC 1996](#).

### **Note**

As a secondary zone can also be a primary to other secondaries, *named*, by default, sends NOTIFY messages for every zone it loads.

## 6.3 Incremental Zone Transfers (IXFR)

The incremental zone transfer (IXFR) protocol is a way for secondary servers to transfer only changed data, instead of having to transfer an entire zone. The IXFR protocol is specified in [RFC 1995](#).

When acting as a primary server, BIND 9 supports IXFR for those zones where the necessary change history information is available. These include primary zones maintained by dynamic update and secondary zones whose data was obtained by IXFR. For manually maintained primary zones, and for secondary zones obtained by performing a full zone transfer (AXFR), IXFR is supported only if the option *ixfr-from-differences* is set to *yes*.

When acting as a secondary server, BIND 9 attempts to use IXFR unless it is explicitly disabled. For more information about disabling IXFR, see the description of the *request-ixfr* clause of the *server* statement.

When a secondary server receives a zone via AXFR, it creates a new copy of the zone database and then swaps it into place; during the loading process, queries continue to be served from the old database with no interference. When receiving a zone via IXFR, however, changes are applied to the running zone, which may degrade query performance during the transfer. If a server receiving an IXFR request determines that the response size would be similar in size to an AXFR response, it may wish to send AXFR instead. The threshold at which this determination is made can be configured using the *max-ixfr-ratio* option.

## 6.4 Split DNS

Setting up different views of the DNS space to internal and external resolvers is usually referred to as a *split DNS* setup. There are several reasons an organization might want to set up its DNS this way.

One common reason to use split DNS is to hide "internal" DNS information from "external" clients on the Internet. There is some debate as to whether this is actually useful. Internal DNS information leaks out in many ways (via email headers, for example) and most savvy "attackers" can find the information they need using other means. However, since listing addresses of internal servers that external clients cannot possibly reach can result in connection delays and other annoyances, an organization may choose to use split DNS to present a consistent view of itself to the outside world.

Another common reason for setting up a split DNS system is to allow internal networks that are behind filters or in [RFC 1918](#) space (reserved IP space, as documented in [RFC 1918](#)) to resolve DNS on the Internet. Split DNS can also be used to allow mail from outside back into the internal network.

### 6.4.1 Example Split DNS Setup

Let's say a company named *Example, Inc.* (*example.com*) has several corporate sites that have an internal network with reserved Internet Protocol (IP) space and an external demilitarized zone (DMZ), or "outside" section of a network, that is available to the public.

Example, Inc. wants its internal clients to be able to resolve external hostnames and to exchange mail with people on the outside. The company also wants its internal resolvers to have access to certain internal-only zones that are not available at all outside of the internal network.

To accomplish this, the company sets up two sets of name servers. One set is on the inside network (in the reserved IP space) and the other set is on bastion hosts, which are "proxy" hosts in the DMZ that can talk to both sides of its network.

The internal servers are configured to forward all queries, except queries for `site1.internal`, `site2.internal`, `site1.example.com`, and `site2.example.com`, to the servers in the DMZ. These internal servers have complete sets of information for `site1.example.com`, `site2.example.com`, `site1.internal`, and `site2.internal`.

To protect the `site1.internal` and `site2.internal` domains, the internal name servers must be configured to disallow all queries to these domains from any external hosts, including the bastion hosts.

The external servers, which are on the bastion hosts, are configured to serve the "public" version of the `site1.example.com` and `site2.example.com` zones. This could include things such as the host records for public servers (`www.example.com` and `ftp.example.com`) and mail exchange (MX) records (`a.mx.example.com` and `b.mx.example.com`).

In addition, the public `site1.example.com` and `site2.example.com` zones should have special MX records that contain wildcard (\*) records pointing to the bastion hosts. This is needed because external mail servers have no other way of determining how to deliver mail to those internal hosts. With the wildcard records, the mail is delivered to the bastion host, which can then forward it on to internal hosts.

Here's an example of a wildcard MX record:

```
*      IN MX 10 external1.example.com.
```

Now that they accept mail on behalf of anything in the internal network, the bastion hosts need to know how to deliver mail to internal hosts. The resolvers on the bastion hosts need to be configured to point to the internal name servers for DNS resolution.

Queries for internal hostnames are answered by the internal servers, and queries for external hostnames are forwarded back out to the DNS servers on the bastion hosts.

For all of this to work properly, internal clients need to be configured to query *only* the internal name servers for DNS queries. This could also be enforced via selective filtering on the network.

If everything has been set properly, Example, Inc.'s internal clients are now able to:

- Look up any hostnames in the `site1.example.com` and `site2.example.com` zones.
- Look up any hostnames in the `site1.internal` and `site2.internal` domains.
- Look up any hostnames on the Internet.
- Exchange mail with both internal and external users.

Hosts on the Internet are able to:

- Look up any hostnames in the `site1.example.com` and `site2.example.com` zones.
- Exchange mail with anyone in the `site1.example.com` and `site2.example.com` zones.

Here is an example configuration for the setup just described above. Note that this is only configuration information; for information on how to configure the zone files, see [Configurations and Zone Files](#).

Internal DNS server config:

```
acl internals { 172.16.72.0/24; 192.168.1.0/24; };
acl externals { bastion-ips-go-here; };
```

(continues on next page)

(continued from previous page)

```
options {
    ...
    ...
    forward only;
    // forward to external servers
    forwarders {
        bastion-ips-go-here;
    };
    // sample allow-transfer (no one)
    allow-transfer { none; };
    // restrict query access
    allow-query { internals; externals; };
    // restrict recursion
    allow-recursion { internals; };
    ...
    ...
};

// sample primary zone
zone "site1.example.com" {
    type primary;
    file "m/site1.example.com";
    // do normal iterative resolution (do not forward)
    forwarders { };
    allow-query { internals; externals; };
    allow-transfer { internals; };
};

// sample secondary zone
zone "site2.example.com" {
    type secondary;
    file "s/site2.example.com";
    primaries { 172.16.72.3; };
    forwarders { };
    allow-query { internals; externals; };
    allow-transfer { internals; };
};

zone "site1.internal" {
    type primary;
    file "m/site1.internal";
    forwarders { };
    allow-query { internals; };
    allow-transfer { internals; };
};

zone "site2.internal" {
    type secondary;
    file "s/site2.internal";
    primaries { 172.16.72.3; };
    forwarders { };
    allow-query { internals; };
};
```

(continues on next page)

(continued from previous page)

```
allow-transfer { internals; }
};
```

External (bastion host) DNS server configuration:

```
acl internals { 172.16.72.0/24; 192.168.1.0/24; };

acl externals { bastion-ips-go-here; };

options {
    ...
    ...
    // sample allow-transfer (no one)
    allow-transfer { none; };
    // default query access
    allow-query { any; };
    // restrict cache access
    allow-query-cache { internals; externals; };
    // restrict recursion
    allow-recursion { internals; externals; };
    ...
    ...
};

// sample secondary zone
zone "site1.example.com" {
    type primary;
    file "m/site1.foo.com";
    allow-transfer { internals; externals; };
};

zone "site2.example.com" {
    type secondary;
    file "s/site2.foo.com";
    primaries { another_bastion_host_maybe; };
    allow-transfer { internals; externals; };
};
```

In the `resolv.conf` (or equivalent) on the bastion host(s):

```
search ...
nameserver 172.16.72.2
nameserver 172.16.72.3
nameserver 172.16.72.4
```

## 6.5 IPv6 Support in BIND 9

BIND 9 fully supports all currently defined forms of IPv6 name-to-address and address-to-name lookups. It also uses IPv6 addresses to make queries when running on an IPv6-capable system.

For forward lookups, BIND 9 supports only AAAA records. [RFC 3363](#) deprecated the use of A6 records, and client-side support for A6 records was accordingly removed from BIND 9. However, authoritative BIND 9 name servers still load

zone files containing A6 records correctly, answer queries for A6 records, and accept zone transfer for a zone containing A6 records.

For IPv6 reverse lookups, BIND 9 supports the traditional "nibble" format used in the `ip6.arpa` domain, as well as the older, deprecated `ip6.int` domain. Older versions of BIND 9 supported the "binary label" (also known as "bitstring") format, but support of binary labels has been completely removed per [RFC 3363](#). Many applications in BIND 9 do not understand the binary label format at all anymore, and return an error if one is given. In particular, an authoritative BIND 9 name server will not load a zone file containing binary labels.

### 6.5.1 Address Lookups Using AAAA Records

The IPv6 AAAA record is a parallel to the IPv4 A record, and, unlike the deprecated A6 record, specifies the entire IPv6 address in a single record. For example:

```
$ORIGIN example.com.
host          3600    IN      AAAA    2001:db8::1
```

Use of IPv4-in-IPv6 mapped addresses is not recommended. If a host has an IPv4 address, use an A record, not a AAAA, with `::ffff:192.168.42.1` as the address.

### 6.5.2 Address-to-Name Lookups Using Nibble Format

When looking up an address in nibble format, the address components are simply reversed, just as in IPv4, and `ip6.arpa.` is appended to the resulting name. For example, the following commands produce a reverse name lookup for a host with address `2001:db8::1`:

```
$ORIGIN 0.0.0.0.0.0.0.0.8.b.d.0.1.0.0.2.ip6.arpa.
1.0.0.0.0.0.0.0.0.0.0.0.0.0.0.0 14400    IN      PTR      (
                                host.example.com. )
```

## 6.6 Dynamically Loadable Zones (DLZ)

Dynamically Loadable Zones (DLZ) are an extension to BIND 9 that allows zone data to be retrieved directly from an external database. There is no required format or schema.

There are number of contributed DLZ modules for several different database backends, including MySQL and LDAP, but they are not actively maintained.

The DLZ module provides data to `named` in text format, which is then converted to DNS wire format by `named`. This conversion, and the lack of any internal caching, places significant limits on the query performance of DLZ modules. Consequently, DLZ is not recommended for use on high-volume servers. However, it can be used in a hidden primary configuration, with secondaries retrieving zone updates via AXFR. Note, however, that DLZ has no built-in support for DNS notify; secondary servers are not automatically informed of changes to the zones in the database.

### 6.6.1 Configuring DLZ

**dlz**

**Grammar zone (primary, redirect, secondary):** `dlz <string>;`

**Grammar topmost, view:**

```
dlz <string> {
    database <string>;
    search <boolean>;
}; // may occur multiple times
```

**Blocks:** topmost, view, zone (primary, redirect, secondary)

**Tags:** zone

Configures a Dynamically Loadable Zone (DLZ) database in *named.conf*.

A DLZ database is configured with a *dlz* statement in *named.conf*:

```
dlz example {
    database "dlopen driver.so args";
    search yes;
};
```

This specifies a DLZ module to search when answering queries; the module is implemented in *driver.so* and is loaded at runtime by the *dlopen* DLZ driver. Multiple *dlz* statements can be specified.

#### **search**

**Grammar:** *search* <boolean>;

**Blocks:** *dlz*, *view.dlz*

**Tags:** *query*

Specifies whether a Dynamically Loadable Zone (DLZ) module is queried for an answer to a query name.

When answering a query, all DLZ modules with *search* set to *yes* are queried to see whether they contain an answer for the query name. The best available answer is returned to the client.

The *search* option in the above example can be omitted, because *yes* is the default value.

If *search* is set to *no*, this DLZ module is *not* searched for the best match when a query is received. Instead, zones in this DLZ must be separately specified in a zone statement. This allows users to configure a zone normally using standard zone-option semantics, but specify a different database backend for storage of the zone's data. For example, to implement NXDOMAIN redirection using a DLZ module for backend storage of redirection rules:

```
dlz other {
    database "dlopen driver.so args";
    search no;
};

zone "." {
    type redirect;
    dlz other;
};
```

## 6.6.2 Sample DLZ Module

For guidance in the implementation of DLZ modules, the *example* directory in the [gitlab.isc.org/isc-projects/dlz-modules](https://gitlab.isc.org/isc-projects/dlz-modules/-/tree/main/example?ref\_type=heads) contains a basic dynamically linkable DLZ module - i.e., one which can be loaded at runtime by the "dlopen" DLZ driver. The example sets up a single zone, whose name is passed to the module as an argument in the *dlz* statement:

```
dlz other {
    database "dlopen driver.so example.nil";
};
```

In the above example, the module is configured to create a zone "example.nil", which can answer queries and AXFR requests and accept DDNS updates. At runtime, prior to any updates, the zone contains an SOA, NS, and a single A record at the apex:

```
example.nil. 3600 IN SOA example.nil. hostmaster.example.nil. (
                123 900 600 86400 3600
            )
example.nil. 3600 IN NS example.nil.
example.nil. 1800 IN A 10.53.0.1
```

The sample driver can retrieve information about the querying client and alter its response on the basis of this information. To demonstrate this feature, the example driver responds to queries for "source-addr.<zonename>/TXT" with the source address of the query. Note, however, that this record will *not* be included in AXFR or ANY responses. Normally, this feature is used to alter responses in some other fashion, e.g., by providing different address records for a particular name depending on the network from which the query arrived.

Documentation of the DLZ module API can be found in [README](https://gitlab.isc.org/isc-projects/dlz-modules/-/raw/main/example/README). This repository also contains the header file [dlz\_minimal.h](https://gitlab.isc.org/isc-projects/dlz-modules/-/raw/main/modules/include/dlz\_minimal.h), which defines the API and should be included by any dynamically linkable DLZ module.

## 6.7 Dynamic Database (DynDB)

Dynamic Database, or DynDB, is an extension to BIND 9 which, like DLZ (see *Dynamically Loadable Zones (DLZ)*), allows zone data to be retrieved from an external database. Unlike DLZ, a DynDB module provides a full-featured BIND zone database interface. Where DLZ translates DNS queries into real-time database lookups, resulting in relatively poor query performance, and is unable to handle DNSSEC-signed data due to its limited API, a DynDB module can pre-load an in-memory database from the external data source, providing the same performance and functionality as zones served natively by BIND.

A DynDB module supporting LDAP has been created by Red Hat and is available from <https://pagure.io/bind-dyndb-ldap>.

A sample DynDB module for testing and developer guidance is included with the BIND source code, in the directory `bin/tests/system/dyndb/driver`.

### 6.7.1 Configuring DynDB

#### **dyndb**

**Grammar:** `dyndb <string> <quoted_string> { <unspecified-text> };` // may occur multiple times

**Blocks:** topmost, view

**Tags:** zone

Configures a DynDB database in `named.conf`.

A DynDB database is configured with a `dyndb` statement in `named.conf`:

```
dyndb example "driver.so" {
    parameters
};
```

The file `driver.so` is a DynDB module which implements the full DNS database API. Multiple `dyndb` statements can be specified, to load different drivers or multiple instances of the same driver. Zones provided by a DynDB module are added to the view's zone table, and are treated as normal authoritative zones when BIND responds to queries. Zone configuration is handled internally by the DynDB module.

The parameters are passed as an opaque string to the DynDB module's initialization routine. Configuration syntax differs depending on the driver.

## 6.7.2 Sample DynDB Module

For guidance in the implementation of DynDB modules, the directory `bin/tests/system/dyndb/driver` contains a basic DynDB module. The example sets up two zones, whose names are passed to the module as arguments in the `dyndb` statement:

```
dyndb sample "sample.so" { example.nil. arpa. };
```

In the above example, the module is configured to create a zone, "example.nil", which can answer queries and AXFR requests and accept DDNS updates. At runtime, prior to any updates, the zone contains an SOA, NS, and a single A record at the apex:

```
example.nil. 86400 IN SOA example.nil. example.nil. (
                                0 28800 7200 604800 86400
                                )
example.nil. 86400 IN NS example.nil.
example.nil. 86400 IN A 127.0.0.1
```

When the zone is updated dynamically, the DynDB module determines whether the updated RR is an address (i.e., type A or AAAA); if so, it automatically updates the corresponding PTR record in a reverse zone. Note that updates are not stored permanently; all updates are lost when the server is restarted.

## 6.8 Catalog Zones

A "catalog zone" is a special DNS zone that contains a list of other zones to be served, along with their configuration parameters. Zones listed in a catalog zone are called "member zones." When a catalog zone is loaded or transferred to a secondary server which supports this functionality, the secondary server creates the member zones automatically. When the catalog zone is updated (for example, to add or delete member zones, or change their configuration parameters), those changes are immediately put into effect. Because the catalog zone is a normal DNS zone, these configuration changes can be propagated using the standard AXFR/IXFR zone transfer mechanism.

The format and behavior of catalog zones are specified in [RFC 9432](#).

### 6.8.1 Principle of Operation

Normally, if a zone is to be served by a secondary server, the `named.conf` file on the server must list the zone, or the zone must be added using `rndc addzone`. In environments with a large number of secondary servers, and/or where the zones being served are changing frequently, the overhead involved in maintaining consistent zone configuration on all the secondary servers can be significant.

A catalog zone is a way to ease this administrative burden: it is a DNS zone that lists member zones that should be served by secondary servers. When a secondary server receives an update to the catalog zone, it adds, removes, or reconfigures member zones based on the data received.

To use a catalog zone, it must first be set up as a normal zone on both the primary and secondary servers that are configured to use it. It must also be added to a `catalog-zones` list in the `options` or `view` statement in `named.conf`. This is comparable to the way a policy zone is configured as a normal zone and also listed in a `response-policy` statement.

To use the catalog zone feature to serve a new member zone:

- Set up the member zone to be served on the primary as normal. This can be done by editing *named.conf* or by running *rndc addzone*.
- Add an entry to the catalog zone for the new member zone. This can be done by editing the catalog zone's zone file and running *rndc reload*, or by updating the zone using *nsupdate*.

The change to the catalog zone is propagated from the primary to all secondaries using the normal AXFR/IXFR mechanism. When the secondary receives the update to the catalog zone, it detects the entry for the new member zone, creates an instance of that zone on the secondary server, and points that instance to the *primaries* specified in the catalog zone data. The newly created member zone is a normal secondary zone, so BIND immediately initiates a transfer of zone contents from the primary. Once complete, the secondary starts serving the member zone.

Removing a member zone from a secondary server requires only deleting the member zone's entry in the catalog zone; the change to the catalog zone is propagated to the secondary server using the normal AXFR/IXFR transfer mechanism. The secondary server, on processing the update, notices that the member zone has been removed, stops serving the zone, and removes it from its list of configured zones. However, removing the member zone from the primary server must be done by editing the configuration file or running *rndc delzone*.

## 6.8.2 Configuring Catalog Zones

### catalog-zones

**Grammar:** catalog-zones { zone <string> [ default-primaries [ port <integer> ] { ( <remote-servers> | <ipv4\_address> [ port <integer> ] | <ipv6\_address> [ port <integer> ] ) [ key <string> ] [ tls <string> ]; ... } ] [ zone-directory <quoted\_string> ] [ in-memory <boolean> ] [ min-update-interval <duration> ]; ... };

**Blocks:** options, view

**Tags:** zone

Configures catalog zones in *named.conf*.

Catalog zones are configured with a *catalog-zones* statement in the *options* or *view* section of *named.conf*. For example:

```
catalog-zones {
    zone "catalog.example"
    default-primaries { 10.53.0.1; }
    in-memory no
    zone-directory "catzones"
    min-update-interval 10;
};
```

This statement specifies that the zone *catalog.example* is a catalog zone. This zone must be properly configured in the same view. In most configurations, it would be a secondary zone.

The options following the zone name are not required, and may be specified in any order.

#### default-masters

Synonym for *default-primaries*.

#### default-primaries

This option defines the default primaries for member zones listed in a catalog zone, and can be overridden by options within a catalog zone. If no such options are included, then member zones transfer their contents from the servers listed in this option.

**in-memory**

This option, if set to `yes`, causes member zones to be stored only in memory. This is functionally equivalent to configuring a secondary zone without a `file` option. The default is `no`; member zones' content is stored locally in a file whose name is automatically generated from the view name, catalog zone name, and member zone name.

**zone-directory**

This option causes local copies of member zones' zone files to be stored in the specified directory, if `in-memory` is not set to `yes`. The default is to store zone files in the server's working directory. A non-absolute pathname in `zone-directory` is assumed to be relative to the working directory.

**min-update-interval**

This option sets the minimum interval between updates to catalog zones, in seconds. If an update to a catalog zone (for example, via IXFR) happens less than `min-update-interval` seconds after the most recent update, the changes are not carried out until this interval has elapsed. The default is 5 seconds.

Catalog zones are defined on a per-view basis. Configuring a non-empty `catalog-zones` statement in a view automatically turns on `allow-new-zones` for that view. This means that `rndc addzone` and `rndc delzone` also work in any view that supports catalog zones.

### 6.8.3 Catalog Zone Format

A catalog zone is a regular DNS zone; therefore, it must have a single SOA and at least one NS record.

A record stating the version of the catalog zone format is also required. If the version number listed is not supported by the server, then a catalog zone may not be used by that server.

```
catalog.example.      IN SOA . . 2016022901 900 600 86400 1
catalog.example.     IN NS invalid.
version.catalog.example.  IN TXT "2"
```

Note that this record must have the domain name `version.catalog-zone-name`. The data stored in a catalog zone is indicated by the domain name label immediately before the catalog zone domain. Currently BIND supports catalog zone schema versions "1" and "2".

Also note that the catalog zone must have an NS record in order to be a valid DNS zone, and using the value "invalid." for NS is recommended.

A member zone is added by including a PTR resource record in the `zones` sub-domain of the catalog zone. The record label can be any unique label. The target of the PTR record is the member zone name. For example, to add member zones `domain.example` and `domain2.example`:

```
5960775ba382e7a4e09263fc06e7c00569b6a05c.zones.catalog.example. IN PTR domain.example.
uniquelabel.zones.catalog.example. IN PTR domain2.example.
```

The label is necessary to identify custom properties (see below) for a specific member zone. Also, the zone state can be reset by changing its label, in which case BIND will remove the member zone and add it back.

### 6.8.4 Catalog Zone Custom Properties

BIND uses catalog zones custom properties to define different properties which can be set either globally for the whole catalog zone or for a single member zone. Global custom properties override the settings in the configuration file, and member zone custom properties override global custom properties.

For the version "1" of the schema custom properties must be placed without a special suffix.

For the version "2" of the schema custom properties must be placed under the ".ext" suffix.

Global custom properties are set at the apex of the catalog zone, e.g.:

```
primaries.ext.catalog.example.      IN AAAA 2001:db8::1
```

BIND currently supports the following custom properties:

- A simple *primaries* definition:

```
primaries.ext.catalog.example.      IN A 192.0.2.1
```

This custom property defines a primary server for the member zones, which can be either an A or AAAA record. If multiple primaries are set, the order in which they are used is random.

Note: *masters* can be used as a synonym for *primaries*.

- A *primaries* with a TSIG key defined:

```
label.primaries.ext.catalog.example.  IN A 192.0.2.2
label.primaries.ext.catalog.example.  IN TXT "tsig_key_name"
```

This custom property defines a primary server for the member zone with a TSIG key set. The TSIG key must be configured in the configuration file. *label* can be any valid DNS label.

Note: *masters* can be used as a synonym for *primaries*.

- *allow-query* and *allow-transfer* ACLs:

```
allow-query.ext.catalog.example.     IN APL 1:10.0.0.1/24
allow-transfer.ext.catalog.example.   IN APL !1:10.0.0.1/32 1:10.0.0.0/24
```

These custom properties are the equivalents of *allow-query* and *allow-transfer* options in a zone declaration in the *named.conf* configuration file. The ACL is processed in order; if there is no match to any rule, the default policy is to deny access. For the syntax of the APL RR, see [RFC 3123](#).

The member zone-specific custom properties are defined the same way as global custom properties, but in the member zone subdomain:

```
primaries.ext.5960775ba382e7a4e09263fc06e7c00569b6a05c.zones.catalog.example. IN A
↪192.0.2.2
label.primaries.ext.5960775ba382e7a4e09263fc06e7c00569b6a05c.zones.catalog.example.
↪IN AAAA 2001:db8::2
label.primaries.ext.5960775ba382e7a4e09263fc06e7c00569b6a05c.zones.catalog.example.
↪IN TXT "tsig_key_name"
allow-query.ext.5960775ba382e7a4e09263fc06e7c00569b6a05c.zones.catalog.example. IN
↪APL 1:10.0.0.0/24
primaries.ext.uniquelabel.zones.catalog.example. IN A 192.0.2.3
```

Custom properties defined for a specific zone override the global custom properties defined in the catalog zone. These in turn override the global options defined in the *catalog-zones* statement in the configuration file.

Note that none of the global records for a custom property are inherited if any records are defined for that custom property for the specific zone. For example, if the zone had a *primaries* record of type A but not AAAA, it would *not* inherit the type AAAA record from the global custom property or from the global option in the configuration file.

### 6.8.5 Change of Ownership (coo)

BIND supports the catalog zones "Change of Ownership" (coo) property. When the same entry which exists in one catalog zone is added into another catalog zone, the default behavior for BIND is to ignore it, and continue serving the zone using the catalog zone where it was originally existed, unless it is removed from there, then it can be added into the new one.

Using the `coo` property it is possible to gracefully move a zone from one catalog zone into another, by letting the catalog consumers know that it is permitted to do so. To do that, the original catalog zone should be updated with a new record with `coo` custom property:

```
uniquelabel.zones.catalog.example. IN PTR domain2.example.
coo.uniquelabel.zones.catalog.example. IN PTR catalog2.example.
```

Here, the `catalog.example` catalog zone gives permission for the member zone with label "uniquelabel" to be transferred into `catalog2.example` catalog zone. Catalog consumers which support the `coo` property will then take note, and when the zone is finally added into `catalog2.example` catalog zone, catalog consumers will change the ownership of the zone from `catalog.example` to `catalog2.example`. BIND's implementation simply deletes the zone from the old catalog zone and adds it back into the new catalog zone, which also means that all associated state for the just migrated zone will be reset, including when the unique label is the same.

The record with `coo` custom property can be later deleted by the catalog zone operator after confirming that all the consumers have received it and have successfully changed the ownership of the zone.

## 6.9 DNS Firewalls and Response Policy Zones

A DNS firewall examines DNS traffic and allows some responses to pass through while blocking others. This examination can be based on several criteria, including the name requested, the data (such as an IP address) associated with that name, or the name or IP address of the name server that is authoritative for the requested name. Based on these criteria, a DNS firewall can be configured to discard, modify, or replace the original response, allowing administrators more control over what systems can access or be accessed from their networks.

DNS Response Policy Zones (RPZ) are a form of DNS firewall in which the firewall rules are expressed within the DNS itself - encoded in an open, vendor-neutral format as records in specially constructed DNS zones.

Using DNS zones to configure policy allows policy to be shared from one server to another using the standard DNS zone transfer mechanism. This allows a DNS operator to maintain their own firewall policies and share them easily amongst their internal name servers, or to subscribe to external firewall policies such as commercial or cooperative "threat feeds," or both.

*named* can subscribe to up to 64 Response Policy Zones, each of which encodes a separate policy rule set. Each rule is stored in a DNS resource record set (RRset) within the RPZ, and consists of a **trigger** and an **action**. There are five types of triggers and six types of actions.

A response policy rule in a DNS RPZ can be triggered as follows:

- by the IP address of the client
- by the query name
- by an address which would be present in a truthful response
- by the name or address of an authoritative name server responsible for publishing the original response

A response policy action can be one of the following:

- to synthesize a "domain does not exist" (NXDOMAIN) response
- to synthesize a "name exists but there are no records of the requested type" (NODATA) response
- to drop the response
- to switch to TCP by sending a truncated UDP response that requires the DNS client to try again with TCP
- to replace/override the response's data with specific data (provided within the response policy zone)
- to exempt the response from further policy processing

The most common use of a DNS firewall is to "poison" a domain name, IP address, name server name, or name server IP address. Poisoning is usually done by forcing a synthetic "domain does not exist" (NXDOMAIN) response. This means that if an administrator maintains a list of known "phishing" domains, these names can be made unreachable by customers or end users just by adding a firewall policy into the recursive DNS server, with a trigger for each known "phishing" domain, and an action in every case forcing a synthetic NXDOMAIN response. It is also possible to use a data-replacement action such as answering for these known "phishing" domains with the name of a local web server that can display a warning page. Such a web server would be called a "walled garden."

**Note**

Authoritative name servers can be responsible for many different domains. If DNS RPZ is used to poison all domains served by some authoritative name server name or address, the effects can be quite far-reaching. Users are advised to ensure that such authoritative name servers do not also serve domains that should not be poisoned.

### 6.9.1 Why Use a DNS Firewall?

Criminal and network abuse traffic on the Internet often uses the Domain Name System (DNS), so protection against these threats should include DNS firewalling. A DNS firewall can selectively intercept DNS queries for known network assets including domain names, IP addresses, and name servers. Interception can mean rewriting a DNS response to direct a web browser to a "walled garden," or simply making any malicious network assets invisible and unreachable.

### 6.9.2 What Can a DNS Firewall Do?

Firewalls work by applying a set of rules to a traffic flow, where each rule consists of a trigger and an action. Triggers determine which messages within the traffic flow are handled specially, and actions determine what that special handling is. For a DNS firewall, the traffic flow to be controlled consists of responses sent by a recursive DNS server to its end-user clients. Some true responses are not safe for all clients, so the policy rules in a DNS firewall allow some responses to be intercepted and replaced with safer content.

### 6.9.3 Creating and Maintaining RPZ Rule Sets

In DNS RPZ, the DNS firewall policy rule set is stored in a DNS zone, which is maintained and synchronized using the same tools and methods as for any other DNS zone. The primary name server for a DNS RPZ may be an internal server, if an administrator is creating and maintaining their own DNS policy zone, or it may be an external name server (such as a security vendor's server), if importing a policy zone published externally. The primary copy of the DNS firewall policy can be a DNS "zone file" which is either edited by hand or generated from a database. A DNS zone can also be edited indirectly using DNS dynamic updates (for example, using the "nsupdate" shell level utility).

DNS RPZ allows firewall rules to be expressed in a DNS zone format and then carried to subscribers as DNS data. A recursive DNS server which is capable of processing DNS RPZ synchronizes these DNS firewall rules using the same standard DNS tools and protocols used for secondary name service. The DNS policy information is then promoted to the DNS control plane inside the customer's DNS resolver, making that server into a DNS firewall.

A security company whose products include threat intelligence feeds can use a DNS Response Policy Zone (RPZ) as a delivery channel to customers. Threats can be expressed as known-malicious IP addresses and subnets, known-malicious domain names, and known-malicious domain name servers. By feeding this threat information directly into customers' local DNS resolvers, providers can transform these DNS servers into a distributed DNS firewall.

When a customer's DNS resolver is connected by a realtime subscription to a threat intelligence feed, the provider can protect the customer's end users from malicious network elements (including IP addresses and subnets, domain names, and name servers) immediately as they are discovered. While it may take days or weeks to "take down" criminal and abusive infrastructure once reported, a distributed DNS firewall can respond instantly.

Other distributed TCP/IP firewalls have been on the market for many years, and enterprise users are now comfortable importing real-time threat intelligence from their security vendors directly into their firewalls. This intelligence can take

the form of known-malicious IP addresses or subnets, or of patterns which identify known-malicious email attachments, file downloads, or web addresses (URLs). In some products it is also possible to block DNS packets based on the names or addresses they carry.

### 6.9.4 Limitations of DNS RPZ

We're often asked if DNS RPZ could be used to set up redirection to a CDN. For example, if "mydomain.com" is a normal domain with SOA, NS, MX, TXT records etc., then if someone sends an A or AAAA query for "mydomain.com", can we use DNS RPZ on an authoritative nameserver to return "CNAME mydomain.com.my-cdn-provider.net"?

The problem with this suggestion is that there is no way to CNAME only A and AAAA queries, not even with RPZ.

The underlying reason is that if the authoritative server answers with a CNAME, the recursive server making that query will cache the response. Thereafter (while the CNAME is still in cache), it assumes that there are no records of any non-CNAME type for the name that was being queried, and directs subsequent queries for all other types directly to the target name of the CNAME record.

To be clear, this is not a limitation of RPZ; it is a function of the way the DNS protocol works. It's simply not possible to use "partial" CNAMEs to help when setting up CDNs because doing this will break other functionality such as email routing.

Similarly, following the DNS protocol definition, wildcards in the form of \*.example records might behave in unintuitive ways. For a detailed definition of wildcards in DNS, please see [RFC 4592](#), especially section 2.

### 6.9.5 DNS Firewall Usage Examples

Here are some scenarios in which a DNS firewall might be useful.

Some known threats are based on an IP address or subnet (IP address range). For example, an analysis may show that all addresses in a "class C" network are used by a criminal gang for "phishing" web servers. With a DNS firewall based on DNS RPZ, a firewall policy can be created such as "if a DNS lookup would result in an address from this class C network, then answer instead with an NXDOMAIN indication." That simple rule would prevent any end users inside customers' networks from being able to look up any domain name used in this phishing attack – without having to know in advance what those names might be.

Other known threats are based on domain names. An analysis may determine that a certain domain name or set of domain names is being or will shortly be used for spamming, phishing, or other Internet-based attacks which all require working domain names. By adding name-triggered rules to a distributed DNS firewall, providers can protect customers' end users from any attacks which require them to be able to look up any of these malicious names. The names can be wildcards (for example, \*.evil.com), and these wildcards can have exceptions if some domains are not as malicious as others (if \*.evil.com is bad, then not.evil.com might be an exception).

Alongside growth in electronic crime has come growth of electronic criminal expertise. Many criminal gangs now maintain their own extensive DNS infrastructure to support a large number of domain names and a diverse set of IP addressing resources. Analyses show in many cases that the only truly fixed assets criminal organizations have are their name servers, which are by nature slightly less mobile than other network assets. In such cases, DNS administrators can anchor their DNS firewall policies in the abusive name server names or name server addresses, and thus protect their customers' end users from threats where neither the domain name nor the IP address of that threat is known in advance.

Electronic criminals rely on the full resiliency of DNS just as the rest of digital society does. By targeting criminal assets at the DNS level we can deny these criminals the resilience they need. A distributed DNS firewall can leverage the high skills of a security company to protect a large number of end users. DNS RPZ, as the first open and vendor-neutral distributed DNS firewall, can be an effective way to deliver threat intelligence to customers.

## A Real-World Example of DNS RPZ's Value

The Conficker malware worm (<https://en.wikipedia.org/wiki/Conficker>) was first detected in 2008. Although it is no longer an active threat, the techniques described here can be applied to other DNS threats.

Conficker used a domain generation algorithm (DGA) to choose up to 50,000 command and control domains per day. It would be impractical to create an RPZ that contains so many domain names and changes so much on a daily basis. Instead, we can trigger RPZ rules based on the names of the name servers that are authoritative for the command and control domains, rather than trying to trigger on each of 50,000 different (daily) query names. Since the well-known name server names for Conficker's domain names are never used by nonmalicious domains, it is safe to poison all lookups that rely on these name servers. Here is an example that achieves this result:

```
$ORIGIN rpz.example.com.
ns.0xc0f1c3a5.com.rpz-nsdname CNAME *.walled-garden.example.com.
ns.0xc0f1c3a5.net.rpz-nsdname CNAME *.walled-garden.example.com.
ns.0xc0f1c3a5.org.rpz-nsdname CNAME *.walled-garden.example.com.
```

The \* at the beginning of these CNAME target names is special, and it causes the original query name to be prepended to the CNAME target. So if a user tries to visit the Conficker command and control domain `racaldftn.com.ai` (which was a valid Conficker command and control domain name on 19-October-2011), the RPZ-configured recursive name server will send back this answer:

```
racaldftn.com.ai. CNAME racaldftn.com.ai.walled-garden.example.com.
racaldftn.com.ai.walled-garden.example.com. A 192.168.50.3
```

This example presumes that the following DNS content has also been created, which is not part of the RPZ zone itself but is in another domain:

```
$ORIGIN walled-garden.example.com.
* A 192.168.50.3
```

Assuming that we're running a web server listening on 192.168.50.3 that always displays a warning message no matter what uniform resource identifier (URI) is used, the above RPZ configuration will instruct the web browser of any infected end user to connect to a "server name" consisting of their original lookup name (`racaldftn.com.ai`) prepended to the walled garden domain name (`walled-garden.example.com`). This is the name that will appear in the web server's log file, and having the full name in that log file will facilitate an analysis as to which users are infected with what virus.

## 6.9.6 Keeping Firewall Policies Updated

It is vital for overall system performance that incremental zone transfers (see [RFC 1995](#)) and real-time change notification (see [RFC 1996](#)) be used to synchronize DNS firewall rule sets between the publisher's primary copy of the rule set and the subscribers' working copies of the rule set.

If DNS dynamic updates are used to maintain a DNS RPZ rule set, the name server automatically calculates a stream of deltas for use when sending incremental zone transfers to the subscribing name servers. Sending a stream of deltas – known as an "incremental zone transfer" or IXFR – is usually much faster than sending the full zone every time it changes, so it's worth the effort to use an editing method that makes such incremental transfers possible.

Administrators who edit or periodically regenerate a DNS RPZ rule set and whose primary name server uses BIND can enable the `ixfr-from-differences` option, which tells the primary name server to calculate the differences between each new zone and the preceding version, and to make these differences available as a stream of deltas for use in incremental zone transfers to the subscribing name servers. This will look something like the following:

```
options {
    // ...
    ixfr-from-differences yes;
```

(continues on next page)

(continued from previous page)

```
// ...
};
```

As mentioned above, the simplest and most common use of a DNS firewall is to poison domain names known to be purely malicious, by simply making them disappear. All DNS RPZ rules are expressed as resource record sets (RRsets), and the way to express a "force a name-does-not-exist condition" is by adding a CNAME pointing to the root domain (.). In practice this looks like:

```
$ORIGIN rpz.example.com.
malicious1.org          CNAME .
*.malicious1.org       CNAME .
malicious2.org          CNAME .
*.malicious2.org       CNAME .
```

Two things are noteworthy in this example. First, the malicious names are made relative within the response policy zone. Since there is no trailing dot following ".org" in the above example, the actual RRsets created within this response policy zone are, after expansion:

```
malicious1.org.rpz.example.com.      CNAME .
*.malicious1.org.rpz.example.com.    CNAME .
malicious2.org.rpz.example.com.      CNAME .
*.malicious2.org.rpz.example.com.    CNAME .
```

Second, for each name being poisoned, a wildcard name is also listed. This is because a malicious domain name probably has or may potentially have malicious subdomains.

In the above example, the relative domain names *malicious1.org* and *malicious2.org* will match only the real domain names *malicious1.org* and *malicious2.org*, respectively. The relative domain names *\*.malicious1.org* and *\*.malicious2.org* will match any *subdomain.of.malicious1.org* or *subdomain.of.malicious2.org*, respectively.

This example forces an NXDOMAIN condition as its policy action, but other policy actions are also possible.

### 6.9.7 Performance and Scalability When Using Multiple RPZs

Since version 9.10, BIND can be configured to have different response policies depending on the identity of the querying client and the nature of the query. To configure BIND response policy, the information is placed into a zone file whose only purpose is conveying the policy information to BIND. A zone file containing response policy information is called a Response Policy Zone, or RPZ, and the mechanism in BIND that uses the information in those zones is called DNS RPZ.

It is possible to use as many as 64 separate RPZ files in a single instance of BIND, and BIND is not significantly slowed by such heavy use of RPZ.

(Note: by default, BIND 9.11 only supports up to 32 RPZ files, but this can be increased to 64 at compile time. All other supported versions of BIND support 64 by default.)

Each one of the policy zone files can specify policy for as many different domains as necessary. The limit of 64 is on the number of independently-specified policy collections and not the number of zones for which they specify policy.

Policy information from all of the policy zones together are stored in a special data structure allowing simultaneous lookups across all policy zones to be performed very rapidly. Looking up a policy rule is proportional to the logarithm of the number of rules in the largest single policy zone.

### 6.9.8 Practical Tips for DNS Firewalls and DNS RPZ

Administrators who subscribe to an externally published DNS policy zone and who have a large number of internal recursive name servers should create an internal name server called a "distribution master" (DM). The DM is a secondary (stealth secondary) name server from the publisher's point of view; that is, the DM is fetching zone content from the external server. The DM is also a primary name server from the internal recursive name servers' point of view: they fetch zone content from the DM. In this configuration the DM is acting as a gateway between the external publisher and the internal subscribers.

The primary server must know the unicast listener address of every subscribing recursive server, and must enumerate all of these addresses as destinations for real time zone change notification (as described in [RFC 1996](#)). So if an enterprise-wide RPZ is called "rpz.example.com" and if the unicast listener addresses of four of the subscribing recursive name servers are 192.0.200.1, 192.0.201.1, 192.0.202.1, and 192.0.203.1, the primary server's configuration looks like this:

```
zone "rpz.example.com" {
    type primary;
    file "primary/rpz.example.com";
    notify explicit;
    also-notify { 192.0.200.1;
                 192.0.201.1;
                 192.0.202.1;
                 192.0.203.1; };
    allow-transfer { 192.0.200.1;
                   192.0.201.1;
                   192.0.202.1;
                   192.0.203.1; };
    allow-query { localhost; };
};
```

Each recursive DNS server that subscribes to the policy zone must be configured as a secondary server for the zone, and must also be configured to use the policy zone for local response policy. To subscribe a recursive name server to a response policy zone where the unicast listener address of the primary server is 192.0.220.2, the server's configuration should look like this:

```
options {
    // ...
    response-policy {
        zone "rpz.example.com";
    };
    // ...
};

zone "rpz.example.com";
type secondary;
primaries { 192.0.222.2; };
file "secondary/rpz.example.com";
allow-query { localhost; };
allow-transfer { none; };
};
```

Note that queries are restricted to "localhost," since query access is never used by DNS RPZ itself, but may be useful to DNS operators for use in debugging. Transfers should be disallowed to prevent policy information leaks.

If an organization's business continuity depends on full connectivity with another company whose ISP also serves some criminal or abusive customers, it's possible that one or more external RPZ providers – that is, security feed vendors – may eventually add some RPZ rules that could hurt a company's connectivity to its business partner. Users can protect

themselves from this risk by using an internal RPZ in addition to any external RPZs, and by putting into their internal RPZ some "pass-through" rules to prevent any policy action from affecting a DNS response that involves a business partner.

A recursive DNS server can be connected to more than one RPZ, and these are searched in order. Therefore, to protect a network from dangerous policies which may someday appear in external RPZ zones, administrators should list the internal RPZ zones first.

```
options {
  // ...
  response-policy {
    zone "rpz.example.com";
    zone "rpz.security-vendor-1.com";
    zone "rpz.security-vendor-2.com";
  };
  // ...
};
```

Within an internal RPZ, there need to be rules describing the network assets of business partners whose communications need to be protected. Although it is not generally possible to know what domain names they use, administrators will be aware of what address space they have and perhaps what name server names they use.

```
$ORIGIN rpz.example.com.
8.0.0.0.10.rpz-ip           CNAME   rpz-passthru.
16.0.0.45.128.rpz-nsip     CNAME   rpz-passthru.
ns.partner1.com.rpz-nsdname CNAME   rpz-passthru.
ns.partner2.com.rpz-nsdname CNAME   rpz-passthru.
```

Here, we know that answers in address block 10.0.0.0/8 indicate a business partner, as well as answers involving any name server whose address is in the 128.45.0.0/16 address block, and answers involving the name servers whose names are ns.partner1.com or ns.partner2.com.

The above example demonstrates that when matching by answer IP address (the .rpz-ip owner), or by name server IP address (the .rpz-nsip owner) or by name server domain name (the .rpz-nsdname owner), the special RPZ marker (.rpz-ip, .rpz-nsip, or .rpz-nsdname) does not appear as part of the CNAME target name.

By triggering these rules using the known network assets of a partner, and using the "pass-through" policy action, no later RPZ processing (which in the above example refers to the "rpz.security-vendor-1.com" and "rpz.security-vendor-2.com" policy zones) will have any effect on DNS responses for partner assets.

### 6.9.9 Creating a Simple Walled Garden Triggered by IP Address

It may be the case that the only thing known about an attacker is the IP address block they are using for their "phishing" web servers. If the domain names and name servers they use are unknown, but it is known that every one of their "phishing" web servers is within a small block of IP addresses, a response can be triggered on all answers that would include records in this address range, using RPZ rules that look like the following example:

```
$ORIGIN rpz.example.com.
22.0.212.94.109.rpz-ip     CNAME   drop.garden.example.com.
*.212.94.109.in-addr.arpa  CNAME   .
*.213.94.109.in-addr.arpa  CNAME   .
*.214.94.109.in-addr.arpa  CNAME   .
*.215.94.109.in-addr.arpa  CNAME   .
```

Here, if a truthful answer would include an A (address) RR (resource record) whose value were within the 109.94.212.0/22 address block, then a synthetic answer is sent instead of the truthful answer. Assuming the query is for www.malicious.net, the synthetic answer is:

```
www.malicious.net.      CNAME  drop.garden.example.com.
drop.garden.example.com.  A      192.168.7.89
```

This assumes that *drop.garden.example.com* has been created as real DNS content, outside of the RPZ:

```
$ORIGIN example.com.
drop.garden            A      192.168.7.89
```

In this example, there is no "\*" in the CNAME target name, so the original query name will not be present in the walled garden web server's log file. This is an undesirable loss of information, and is shown here for example purposes only.

The above example RPZ rules would also affect address-to-name (also known as "reverse DNS") lookups for the unwanted addresses. If a mail or web server receives a connection from an address in the example's 109.94.212.0/22 address block, it will perform a PTR record lookup to find the domain name associated with that IP address.

This kind of address-to-name translation is usually used for diagnostic or logging purposes, but it is also common for email servers to reject any email from IP addresses which have no address-to-name translation. Most mail from such IP addresses is spam, so the lack of a PTR record here has some predictive value. By using the "force name-does-not-exist" policy trigger on all lookups in the PTR name space associated with an address block, DNS administrators can give their servers a hint that these IP addresses are probably sending junk.

### 6.9.10 A Known Inconsistency in DNS RPZ's NSDNAME and NSIP Rules

Response Policy Zones define several possible triggers for each rule, and among these two are known to produce inconsistent results. This is not a bug; rather, it relates to inconsistencies in the DNS delegation model.

#### DNS Delegation

In DNS authority data, an NS RRset that is not at the apex of a DNS zone creates a sub-zone. That sub-zone's data is separate from the current (or "parent") zone, and it can have different authoritative name servers than the current zone. In this way, the root zone leads to COM, NET, ORG, and so on, each of which have their own name servers and their own way of managing their authoritative data. Similarly, ORG has delegations to ISC.ORG and to millions of other "dot-ORG" zones, each of which can have its own set of authoritative name servers. In the parlance of the protocol, these NS RRsets below the apex of a zone are called "delegation points." An NS RRset at a delegation point contains a list of authoritative servers to which the parent zone is delegating authority for all names at or below the delegation point.

At the apex of every zone there is also an NS RRset. Ideally, this so-called "apex NS RRset" should be identical to the "delegation point NS RRset" in the parent zone, but this ideal is not always achieved. In the real DNS, it's almost always easier for a zone administrator to update one of these NS RRsets than the other, so that one will be correct and the other out of date. This inconsistency is so common that it's been necessarily rendered harmless: domains that are inconsistent in this way are less reliable and perhaps slower, but they still function as long as there is some overlap between each of the NS RRsets and the truth. ("Truth" in this case refers to the actual set of name servers that are authoritative for the zone.)

#### A Quick Review of DNS Iteration

In DNS recursive name servers, an incoming query that cannot be answered from the local cache is sent to the closest known delegation point for the query name. For example, if a server is looking up XYZZY.ISC.ORG and it the name servers for ISC.ORG, then it sends the query to those servers directly; however, if it has never heard of ISC.ORG before, it must first send the query to the name servers for ORG (or perhaps even to the root zone that is the parent of ORG).

When it asks one of the parent name servers, that server will not have an answer, so it sends a "referral" consisting only of the "delegation point NS RRset." Once the server receives this referral, it "iterates" by sending the same query again, but this time to name servers for a more specific part of the query name. Eventually this iteration terminates, usually by getting an answer or a "name error" (NXDOMAIN) from the query name's authoritative server, or by encountering some type of server failure.

When an authoritative server for the query name sends an answer, it has the option of including a copy of the zone's apex NS RRset. If this occurs, the recursive name server caches this NS RRset, replacing the delegation point NS RRset that it had received during the iteration process. In the parlance of the DNS, the delegation point NS RRset is "glue," meaning non-authoritative data, or more of a hint than a real truth. On the other hand, the apex NS RRset is authoritative data, coming as it does from the zone itself, and it is considered more credible than the "glue." For this reason, it's a little bit more important that the apex NS RRset be correct than that the delegation point NS RRset be correct, since the former will quickly replace the latter, and will be used more often for a longer total period of time.

Importantly, the authoritative name server need not include its apex NS RRset in any answers, and recursive name servers do not ordinarily query directly for this RRset. Therefore it is possible for the apex NS RRset to be completely wrong without any operational ill-effects, since the wrong data need not be exposed. Of course, if a query comes in for this NS RRset, most recursive name servers will forward the query to the zone's authority servers, since it's bad form to return "glue" data when asked a specific question. In these corner cases, bad apex NS RRset data can cause a zone to become unreachable unpredictably, according to what other queries the recursive name server has processed.

There is another kind of "glue," for name servers whose names are below delegation points. If ORG delegates ISC.ORG to NS-EXT.ISC.ORG, the ORG server needs to know an address for NS-EXT.ISC.ORG and return this address as part of the delegation response. However, the name-to-address binding for this name server is only authoritative inside the ISC.ORG zone; therefore, the A or AAAA RRset given out with the delegation is non-authoritative "glue," which is replaced by an authoritative RRset if one is seen. As with apex NS RRsets, the real A or AAAA RRset is not automatically queried for by the recursive name server, but is queried for if an incoming query asks for this RRset.

## Enter RPZ

RPZ has two trigger types that are intended to allow policy zone authors to target entire groups of domains based on those domains all being served by the same DNS servers: NSDNAME and NSIP. The NSDNAME and NSIP rules are matched against the name and IP address (respectively) of the nameservers of the zone the answer is in, and all of its parent zones. In its default configuration, BIND actively fetches any missing NS RRsets and address records. If, in the process of attempting to resolve the names of all of these delegated server names, BIND receives a SERVFAIL response for any of the queries, then it aborts the policy rule evaluation and returns SERVFAIL for the query. This is technically neither a match nor a non-match of the rule.

Every "." in a fully qualified domain name (FQDN) represents a potential delegation point. When BIND goes searching for parent zone NS RRsets (and, in the case of NSIP, their accompanying address records), it has to check every possible delegation point. This can become a problem for some specialized pseudo-domains, such as some domain name and network reputation systems, that have many "." characters in the names. It is further complicated if that system also has non-compliant DNS servers that silently drop queries for NS and SOA records. This forces BIND to wait for those queries to time out before it can finish evaluating the policy rule, even if this takes longer than a reasonable client typically waits for an answer (delays of over 60 seconds have been observed).

While both of these cases do involve configurations and/or servers that are technically "broken," they may still "work" outside of RPZ NSIP and NSDNAME rules because of redundancy and iteration optimizations.

There are two RPZ options, `nsip-wait-recurse` and `nsdname-wait-recurse`, that alter BIND's behavior by allowing it to use only those records that already exist in the cache when evaluating NSIP and NSDNAME rules, respectively.

Therefore NSDNAME and NSIP rules are unreliable. The rules may be matched against either the apex NS RRset or the "glue" NS RRset, each with their associated addresses (that also might or might not be "glue"). It's in the administrator's interests to discover both the delegation name server names and addresses, and the apex name server names and authoritative address records, to ensure correct use of NS and NSIP triggers in RPZ. Even then, there may be collateral damage to completely unrelated domains that otherwise "work," just by having NSIP and NSDNAME rules.

### 6.9.11 Example: Using RPZ to Disable Mozilla DoH-by-Default

Mozilla announced in September 2019 that they would enable DNS-over-HTTPS (DoH) for all US-based users of the Firefox browser, sending all their DNS queries to predefined DoH providers (Cloudflare's 1.1.1.1 service in particular). This is a concern for some network administrators who do not want their users' DNS queries to be rerouted unexpectedly. However, Mozilla provides a mechanism to disable the DoH-by-default setting: if the Mozilla-owned domain `use-application-dns.net` returns an NXDOMAIN response code, Firefox will not use DoH.

To accomplish this using RPZ:

1. Create a policy zone file called `mozilla.rpz.db` configured so that NXDOMAIN will be returned for any query to `use-application-dns.net`:

```
$TTL 604800
$ORIGIN mozilla.rpz.
@ IN SOA localhost. root.localhost. 1 604800 86400 2419200 604800
@ IN NS localhost.
use-application-dns.net CNAME .
```

2. Add the zone into the BIND configuration (usually `named.conf`):

```
zone mozilla.rpz {
    type primary;
    file "<PATH_TO>/mozilla.rpz.db";
    allow-query { localhost; };
};
```

3. Enable use of the Response Policy Zone for all incoming queries by adding the `response-policy` directive into the options `{}` section:

```
options {
    response-policy { zone mozilla.rpz; } break-dnssec yes;
};
```

4. Reload the configuration and test whether the Response Policy Zone that was just added is in effect:

```
# rndc reload
# dig IN A use-application-dns.net @<IP_ADDRESS_OF_YOUR_RESOLVER>
# dig IN AAAA use-application-dns.net @<IP_ADDRESS_OF_YOUR_RESOLVER>
```

The response should return NXDOMAIN instead of the list of IP addresses, and the BIND 9 log should contain lines like this:

```
09-Sep-2019 18:50:49.439 client @0x7faf8e004a00 ::1#54175 (use-application-dns.net):
↳rpz QNAME NXDOMAIN rewrite use-application-dns.net/AAAA/IN via use-application-dns.
↳net.mozilla.rpz
09-Sep-2019 18:50:49.439 client @0x7faf8e007800 127.0.0.1#62915 (use-application-dns.
↳net): rpz QNAME NXDOMAIN rewrite use-application-dns.net/AAAA/IN via use-
↳application-dns.net.mozilla.rpz
```

Note that this is the simplest possible configuration; specific configurations may be different, especially for administrators who are already using other response policy zones, or whose servers are configured with multiple views.

## SECURITY CONFIGURATIONS

### 7.1 Security Assumptions

BIND 9's design assumes that access to the objects listed below is limited only to trusted parties. An incorrect deployment, which does not follow rules set by this section, cannot be the basis for CVE assignment or special security-sensitive handling of issues.

Unauthorized access can potentially disclose sensitive data, slow down server operation, etc. Unauthorized, unexpected, or incorrect writes to any of the following listed objects can potentially cause crashes, incorrect data handling, or corruption:

- All files stored on disk - including zone files, configuration files, key files, temporary files, etc.
- Clients communicating via the *controls* socket using configured keys
- Access to *statistics-channels* from untrusted clients
- Sockets used for *update-policy* type *external*

Certain aspects of the DNS protocol are left unspecified, such as the handling of responses from DNS servers which do not fully conform to the DNS protocol. For such a situation, BIND implements its own safety checks and limits which are subject to change as the protocol and deployment evolve.

#### 7.1.1 Authoritative Servers

By default, zones use intentionally lenient limits (unlimited size, long transfer timeouts, etc.). These defaults can be misused by the source of data (zone transfers or UPDATES) to exhaust resources on the receiving side.

The impact of malicious zone changes can be limited, to an extent, using configuration options listed in sections *Server Resource Limits* and *Zone Transfers*. Limits should also be applied to zones where malicious clients may potentially be authorized to use *Dynamic Update*.

#### 7.1.2 DNS Resolvers

By definition, DNS resolvers act as traffic amplifiers; during normal operation, a DNS resolver can legitimately generate more outgoing traffic (counted in packets or bytes) than the incoming client traffic that triggered it. The DNS protocol specification does not currently specify limits for this amplification, but BIND implements its own limits to balance interoperability and safety. As a general rule, if a traffic amplification factor for any given scenario is lower than 100 packets, ISC does not handle the given scenario as a security issue. These limits are subject to change as DNS deployment evolves.

All DNS answers received by the DNS resolver are treated as untrusted input and are subject to safety and correctness checks. However, protocol non-conformity might cause unexpected behavior. If such unexpected behavior is limited to DNS domains hosted on non-conformant servers, it is not deemed a security issue *in BIND*.

## 7.2 Access Control Lists

Access Control Lists (ACLs) are address match lists that can be set up and nicknamed for future use in *allow-notify*, *allow-query*, *allow-query-on*, *allow-recursion*, *blackhole*, *allow-transfer*, *match-clients*, etc.

ACLs give users finer control over who can access the name server, without cluttering up configuration files with huge lists of IP addresses.

It is a *good idea* to use ACLs, and to control access. Limiting access to the server by outside parties can help prevent spoofing and denial of service (DoS) attacks against the server.

ACLs match clients on the basis of up to three characteristics: 1) The client's IP address; 2) the TSIG key that was used to sign the request, if any; and 3) an address prefix encoded in an EDNS Client-Subnet option, if any.

Here is an example of ACLs based on client addresses:

```
// Set up an ACL named "bogusnets" that blocks
// RFC1918 space and some reserved space, which is
// commonly used in spoofing attacks.
acl bogusnets {
    0.0.0.0/8; 192.0.2.0/24; 224.0.0.0/3;
    10.0.0.0/8; 172.16.0.0/12; 192.168.0.0/16;
};

// Set up an ACL called our-nets. Replace this with the
// real IP numbers.
acl our-nets { x.x.x.x/24; x.x.x.x/21; };
options {
    ...
    ...
    allow-query { our-nets; };
    allow-recursion { our-nets; };
    ...
    blackhole { bogusnets; };
    ...
};

zone "example.com" {
    type primary;
    file "m/example.com";
    allow-query { any; };
};
```

This allows authoritative queries for `example.com` from any address, but recursive queries only from the networks specified in `our-nets`, and no queries at all from the networks specified in `bogusnets`.

In addition to network addresses and prefixes, which are matched against the source address of the DNS request, ACLs may include `key` elements, which specify the name of a TSIG key.

When BIND 9 is built with GeoIP support, ACLs can also be used for geographic access restrictions. This is done by specifying an ACL element of the form: `geoip db database field value`.

The `field` parameter indicates which field to search for a match. Available fields are `country`, `region`, `city`, `continent`, `postal` (postal code), `metro` (metro code), `area` (area code), `tz` (timezone), `isp`, `asnum`, and `domain`.

`value` is the value to search for within the database. A string may be quoted if it contains spaces or other special characters. An `asnum` search for autonomous system number can be specified using the string "ASNNNNN" or the integer NNNN. If a `country` search is specified with a string that is two characters long, it must be a standard ISO-3166-1

two-letter country code; otherwise, it is interpreted as the full name of the country. Similarly, if `region` is the search term and the string is two characters long, it is treated as a standard two-letter state or province abbreviation; otherwise, it is treated as the full name of the state or province.

The `database` field indicates which GeoIP database to search for a match. In most cases this is unnecessary, because most search fields can only be found in a single database. However, searches for `continent` or `country` can be answered from either the `city` or `country` databases, so for these search types, specifying a `database` forces the query to be answered from that database and no other. If a `database` is not specified, these queries are first answered from the `city` database if it is installed, and then from the `country` database if it is installed. Valid database names are `country`, `city`, `asnum`, `isp`, and `domain`.

Some example GeoIP ACLs:

```
geoup country US;
geoup country JP;
geoup db country country Canada;
geoup region WA;
geoup city "San Francisco";
geoup region Oklahoma;
geoup postal 95062;
geoup tz "America/Los_Angeles";
geoup org "Internet Systems Consortium";
```

ACLs use a "first-match" logic rather than "best-match"; if an address prefix matches an ACL element, then that ACL is considered to have matched even if a later element would have matched more specifically. For example, the ACL { `10/8; !10.0.0.1;`  } would actually match a query from 10.0.0.1, because the first element indicates that the query should be accepted, and the second element is ignored.

When using "nested" ACLs (that is, ACLs included or referenced within other ACLs), a negative match of a nested ACL tells the containing ACL to continue looking for matches. This enables complex ACLs to be constructed, in which multiple client characteristics can be checked at the same time. For example, to construct an ACL which allows a query only when it originates from a particular network *and* only when it is signed with a particular key, use:

```
allow-query { !{ !10/8; any; }; key example; };
```

Within the nested ACL, any address that is *not* in the 10/8 network prefix is rejected, which terminates the processing of the ACL. Any address that *is* in the 10/8 network prefix is accepted, but this causes a negative match of the nested ACL, so the containing ACL continues processing. The query is accepted if it is signed by the key `example`, and rejected otherwise. The ACL, then, only matches when *both* conditions are true.

## 7.3 chroot and setuid

On Unix servers, it is possible to run BIND in a *chrooted* environment (using the `chroot()` function) by specifying the `-t` option for `named`. This can help improve system security by placing BIND in a "sandbox," which limits the damage done if a server is compromised.

Another useful feature in the Unix version of BIND is the ability to run the daemon as an unprivileged user (`-u user`). We suggest running as an unprivileged user when using the `chroot` feature.

Here is an example command line to load BIND in a `chroot` sandbox, `/var/named`, and to run `named` `setuid` to user 202:

```
/usr/local/sbin/named -u 202 -t /var/named
```

### 7.3.1 The `chroot` Environment

For a `chroot` environment to work properly in a particular directory (for example, `/var/named`), the environment must include everything BIND needs to run. From BIND's point of view, `/var/named` is the root of the filesystem; the values of options like `directory` and `pid-file` must be adjusted to account for this.

Unlike with earlier versions of BIND, `named` does *not* typically need to be compiled statically, nor do shared libraries need to be installed under the new root. However, depending on the operating system, it may be necessary to set up locations such as `/dev/zero`, `/dev/random`, `/dev/log`, and `/etc/localtime`.

### 7.3.2 Using the `setuid` Function

Prior to running the `named` daemon, use the `touch` utility (to change file access and modification times) or the `chown` utility (to set the user id and/or group id) on files where BIND should write.

#### **Note**

If the `named` daemon is running as an unprivileged user, it cannot bind to new restricted ports if the server is reloaded.

## 7.4 Dynamic Update Security

Access to the dynamic update facility should be strictly limited. In earlier versions of BIND, the only way to do this was based on the IP address of the host requesting the update, by listing an IP address or network prefix in the `allow-update` zone option. This method is insecure, since the source address of the update UDP packet is easily forged. Also note that if the IP addresses allowed by the `allow-update` option include the address of a secondary server which performs forwarding of dynamic updates, the primary can be trivially attacked by sending the update to the secondary, which forwards it to the primary with its own source IP address - causing the primary to approve it without question.

For these reasons, we strongly recommend that updates be cryptographically authenticated by means of transaction signatures (TSIG). That is, the `allow-update` option should list only TSIG key names, not IP addresses or network prefixes. Alternatively, the `update-policy` option can be used.

Some sites choose to keep all dynamically updated DNS data in a subdomain and delegate that subdomain to a separate zone. This way, the top-level zone containing critical data, such as the IP addresses of public web and mail servers, need not allow dynamic updates at all.

## 7.5 TSIG

TSIG (Transaction SIGnatures) is a mechanism for authenticating DNS messages, originally specified in [RFC 2845](#). It allows DNS messages to be cryptographically signed using a shared secret. TSIG can be used in any DNS transaction, as a way to restrict access to certain server functions (e.g., recursive queries) to authorized clients when IP-based access control is insufficient or needs to be overridden, or as a way to ensure message authenticity when it is critical to the integrity of the server, such as with dynamic UPDATE messages or zone transfers from a primary to a secondary server.

This section is a guide to setting up TSIG in BIND. It describes the configuration syntax and the process of creating TSIG keys.

`named` supports TSIG for server-to-server communication, and some of the tools included with BIND support it for sending messages to `named`:

- `nsupdate - dynamic DNS update utility` supports TSIG via the `-k`, `-l`, and `-y` command-line options, or via the `key` command when running interactively.
- `dig - DNS lookup utility` supports TSIG via the `-k` and `-y` command-line options.

### 7.5.1 Generating a Shared Key

TSIG keys can be generated using the `tsig-keygen` command; the output of the command is a `key` directive suitable for inclusion in `named.conf`. The key name, algorithm, and size can be specified by command-line parameters; the defaults are "tsig-key", HMAC-SHA256, and 256 bits, respectively.

Any string which is a valid DNS name can be used as a key name. For example, a key to be shared between servers called `host1` and `host2` could be called "host1-host2.", and this key can be generated using:

```
$ tsig-keygen host1-host2. > host1-host2.key
```

This key may then be copied to both hosts. The key name and secret must be identical on both hosts. (Note: copying a shared secret from one server to another is beyond the scope of the DNS. A secure transport mechanism should be used: secure FTP, SSL, ssh, telephone, encrypted email, etc.)

`tsig-keygen` can also be run as `ddns-confgen`, in which case its output includes additional configuration text for setting up dynamic DNS in `named`. See *ddns-confgen - TSIG key generation tool* for details.

### 7.5.2 Loading a New Key

For a key shared between servers called `host1` and `host2`, the following could be added to each server's `named.conf` file:

```
key "host1-host2." {
    algorithm hmac-sha256;
    secret "DAopyf1mhCbFVZw7pgmNPBoLUq8wEUT7UuPoLENP2HY=";
};
```

(This is the same key generated above using `tsig-keygen`.)

Since this text contains a secret, it is recommended that either `named.conf` not be world-readable, or that the `key` directive be stored in a file which is not world-readable and which is included in `named.conf` via the `include` directive.

Once a key has been added to `named.conf` and the server has been restarted or reconfigured, the server can recognize the key. If the server receives a message signed by the key, it is able to verify the signature. If the signature is valid, the response is signed using the same key.

TSIG keys that are known to a server can be listed using the command `rndc tsig-list`.

### 7.5.3 Instructing the Server to Use a Key

A server sending a request to another server must be told whether to use a key, and if so, which key to use.

For example, a key may be specified for each server in the `primaries` statement in the definition of a secondary zone; in this case, all SOA QUERY messages, NOTIFY messages, and zone transfer requests (AXFR or IXFR) are signed using the specified key. Keys may also be specified in the `also-notify` statement of a primary or secondary zone, causing NOTIFY messages to be signed using the specified key.

Keys can also be specified in a `server` directive. Adding the following on `host1`, if the IP address of `host2` is 10.1.2.3, would cause *all* requests from `host1` to `host2`, including normal DNS queries, to be signed using the `host1-host2.` key:

```
server 10.1.2.3 {
    keys { host1-host2. ;};
};
```

Multiple keys may be present in the `keys` statement, but only the first one is used. As this directive does not contain secrets, it can be used in a world-readable file.

Requests sent by `host2` to `host1` would *not* be signed, unless a similar `server` directive were in `host2`'s configuration file.

When any server sends a TSIG-signed DNS request, it expects the response to be signed with the same key. If a response is not signed, or if the signature is not valid, the response is rejected.

## 7.5.4 TSIG-Based Access Control

TSIG keys may be specified in ACL definitions and ACL directives such as `allow-query`, `allow-transfer`, and `allow-update`. The above key would be denoted in an ACL element as `key host1-host2`.

Here is an example of an `allow-update` directive using a TSIG key:

```
allow-update { !{ !localnets; any; }; key host1-host2. ;};
```

This allows dynamic updates to succeed only if the UPDATE request comes from an address in `localnets`, *and* if it is signed using the `host1-host2` key.

See *Dynamic Update Policies* for a discussion of the more flexible `update-policy` statement.

## 7.5.5 Errors

Processing of TSIG-signed messages can result in several errors:

- If a TSIG-aware server receives a message signed by an unknown key, the response will be unsigned, with the TSIG extended error code set to BADKEY.
- If a TSIG-aware server receives a message from a known key but with an invalid signature, the response will be unsigned, with the TSIG extended error code set to BADSIG.
- If a TSIG-aware server receives a message with a time outside of the allowed range, the response will be signed but the TSIG extended error code set to BADTIME, and the time values will be adjusted so that the response can be successfully verified.

In all of the above cases, the server returns a response code of NOTAUTH (not authenticated).

## 7.6 TKEY

TKEY (Transaction KEY) is a mechanism for automatically negotiating a shared secret between two hosts, originally specified in [RFC 2930](#).

There are several TKEY "modes" that specify how a key is to be generated or assigned. BIND 9 implements only one of these modes: Diffie-Hellman key exchange. Both hosts are required to have a KEY record with algorithm DH (though this record is not required to be present in a zone).

The TKEY process is initiated by a client or server by sending a query of type TKEY to a TKEY-aware server. The query must include an appropriate KEY record in the additional section, and must be signed using either TSIG or SIG(0) with a previously established key. The server's response, if successful, contains a TKEY record in its answer section. After this transaction, both participants have enough information to calculate a shared secret using Diffie-Hellman key exchange. The shared secret can then be used to sign subsequent transactions between the two servers.

TSIG keys known by the server, including TKEY-negotiated keys, can be listed using `rndc tsig-list`.

TKEY-negotiated keys can be deleted from a server using `rndc tsig-delete`. This can also be done via the TKEY protocol itself, by sending an authenticated TKEY query specifying the "key deletion" mode.

## **7.7 SIG(0)**

Support for DNSSEC SIG(0) transaction signatures has been removed. This is a countermeasure for CVE-2024-1975.



## CONFIGURATION REFERENCE

The operational functionality of BIND 9 is defined using the file **named.conf**, which is typically located in `/etc` or `/usr/local/etc/namedb`, depending on the operating system or distribution. A further file **rndc.conf** will be present if **rndc** is being run from a remote host, but is not required if **rndc** is being run from **localhost** (the same system as BIND 9 is running on).

### 8.1 Configuration File (named.conf)

The file `named.conf` may contain three types of entities:

#### Comment

*Multiple comment formats are supported.*

#### Block

*Blocks* are containers for *statements* which either have common functionality - for example, the definition of a cryptographic key in a *key* block - or which define the scope of the statement - for example, a statement which appears in a *zone* block has scope only for that zone.

Blocks are organized hierarchically within `named.conf` and may have a number of different properties:

- Certain blocks cannot be nested inside other blocks and thus may be regarded as the *topmost-level* blocks: for example, the *options* block and the *logging* block.
- Certain blocks can appear multiple times, in which case they have an associated name to disambiguate them: for example, the *zone* block (`zone example.com { ... };`) or the *key* block (`key mykey { ... };`).
- Certain blocks may be "nested" within other blocks. For example, the *zone* block may appear within a *view* block.

The description of each block in this manual lists its permissible locations.

#### Statement

- Statements define and control specific BIND behaviors.
- Statements may have a single parameter (a **Value**) or multiple parameters (**Argument/Value** pairs). For example, the *recursion* statement takes a single value parameter - in this case, the string `yes` or `no` (`recursion yes;`) - while the *port* statement takes a numeric value defining the DNS port number (`port 53;`). More complex statements take one or more argument/value pairs. The *also-notify* statement may take a number of such argument/value pairs, such as `also-notify port 5353;`, where `port` is the argument and `5353` is the corresponding value.
- Statements can appear in a single *block* - for example, an *algorithm* statement can appear only in a *key* block - or in multiple blocks - for example, an *also-notify* statement can appear in an *options* block where it has global (server-wide) scope, in a *zone* block where it has scope only for the specific zone (and

overrides any global statement), or even in a *view* block where it has scope for only that view (and overrides any global statement).

The file `named.conf` may further contain one or more instances of the *include Directive*. This directive is provided for administrative convenience in assembling a complete `named.conf` file and plays no subsequent role in BIND 9 operational characteristics or functionality.

**Note**

Over a period of many years the BIND ARM acquired a bewildering array of terminology. Many of the terms used described similar concepts and served only to add a layer of complexity, possibly confusion, and perhaps mystique to BIND 9 configuration. The ARM now uses only the terms **Block**, **Statement**, **Argument**, **Value**, and **Directive** to describe all entities used in BIND 9 configuration.

### 8.1.1 Comment Syntax

The BIND 9 comment syntax allows comments to appear anywhere that whitespace may appear in a BIND configuration file. To appeal to programmers of all kinds, they can be written in the C, C++, or shell/Perl style.

#### Syntax

```
/* This is a BIND comment as in C */
```

```
// This is a BIND comment as in C++
```

```
# This is a BIND comment as in common Unix shells
# and Perl
```

#### Definition and Usage

Comments can be inserted anywhere that whitespace may appear in a BIND configuration file.

C-style comments start with the two characters `/*` (slash, star) and end with `*/` (star, slash). Because they are completely delimited with these characters, they can be used to comment only a portion of a line or to span multiple lines.

C-style comments cannot be nested. For example, the following is not valid because the entire comment ends with the first `*/`:

```
/* This is the start of a comment.
   This is still part of the comment.
  /* This is an incorrect attempt at nesting a comment. */
   This is no longer in any comment. */
```

C++-style comments start with the two characters `//` (slash, slash) and continue to the end of the physical line. They cannot be continued across multiple physical lines; to have one logical comment span multiple lines, each line must use the `//` pair. For example:

```
// This is the start of a comment. The next line
// is a new comment, even though it is logically
// part of the previous comment.
```

Shell-style (or Perl-style) comments start with the character `#` (number/pound sign) and continue to the end of the physical line, as in C++ comments. For example:

```
# This is the start of a comment.  The next line
# is a new comment, even though it is logically
# part of the previous comment.
```

### Warning

The semicolon (;) character cannot start a comment, unlike in a zone file. The semicolon indicates the end of a configuration statement.

## 8.1.2 Configuration Layout Styles

BIND is very picky about opening and closing brackets/braces, semicolons, and all the other separators defined in the formal syntaxes in later sections. There are many layout styles that can assist in minimizing errors, as shown in the following examples:

```
// dense single-line style
zone "example.com" in{type secondary; file "secondary.example.com"; primaries {10.0.0.
→1;};};
// single-statement-per-line style
zone "example.com" in{
    type secondary;
    file "secondary.example.com";
    primaries {10.0.0.1;};
};
// spot the difference
zone "example.com" in{
    type secondary;
file "sec.secondary.com";
primaries {10.0.0.1;}; };
```

## 8.1.3 include Directive

```
include filename;
```

### include Directive Definition and Usage

The include directive inserts the specified file (or files if a valid [glob expression](#) is detected) at the point where the include directive is encountered. The include directive facilitates the administration of configuration files by permitting the reading or writing of some things but not others. For example, the statement could include private keys that are readable only by the name server.

## 8.1.4 Address Match Lists

### Syntax

An address match list is a list of semicolon-separated *address\_match\_element* s.

```
{ <address_match_element>; ... };
```

Each element is then defined as:

```
address_match_element
```

```
[ ! ] ( <ip_address> | <netprefix> | key <server_key> | <acl_name> | { address_
↪match_list } )
```

## Definition and Usage

Address match lists are primarily used to determine access control for various server operations. They are also used in the *listen-on* and *sortlist* statements. The elements which constitute an address match list can be any of the following:

- *ip\_address*: an IP address (IPv4 or IPv6)
- *netprefix*: an IP prefix (in / notation)
- *server\_key*: a key ID, as defined by the *key* statement
- *acl\_name*: the name of an address match list defined with the *acl* statement
- a nested address match list enclosed in braces

Elements can be negated with a leading exclamation mark (!), and the match list names "any", "none", "localhost", and "localnets" are predefined. More information on those names can be found in the description of the *acl* statement.

The addition of the key clause made the name of this syntactic element something of a misnomer, since security keys can be used to validate access without regard to a host or network address. Nonetheless, the term "address match list" is still used throughout the documentation.

When a given IP address or prefix is compared to an address match list, the comparison takes place in approximately O(1) time. However, key comparisons require that the list of keys be traversed until a matching key is found, and therefore may be somewhat slower.

The interpretation of a match depends on whether the list is being used for access control, defining *listen-on* ports, or in a *sortlist*, and whether the element was negated.

When used as an access control list, a non-negated match allows access and a negated match denies access. If there is no match, access is denied. The clauses *allow-notify*, *allow-recursion*, *allow-recursion-on*, *allow-query*, *allow-query-on*, *allow-query-cache*, *allow-query-cache-on*, *allow-transfer*, *allow-update*, *allow-update-forwarding*, *blackhole*, and *keep-response-order* all use address match lists. Similarly, the *listen-on* option causes the server to refuse queries on any of the machine's addresses which do not match the list.

Order of insertion is significant. If more than one element in an ACL is found to match a given IP address or prefix, preference is given to the one that came *first* in the ACL definition. Because of this first-match behavior, an element that defines a subset of another element in the list should come before the broader element, regardless of whether either is negated. For example, in *1.2.3/24; ! 1.2.3.13*; the *1.2.3.13* element is completely useless because the algorithm matches any lookup for *1.2.3.13* to the *1.2.3/24* element. Using *! 1.2.3.13; 1.2.3/24* fixes that problem by blocking *1.2.3.13* via the negation, but all other *1.2.3.\** hosts pass through.

## 8.1.5 Glossary of Terms Used

Following is a list of terms used throughout the BIND configuration file documentation:

**acl\_name**

The name of an *address\_match\_list* as defined by the *acl* statement.

**address\_match\_list**

See *Address Match Lists*.

**boolean**

Either *yes* or *no*. The words *true* and *false* are also accepted, as are the numbers *1* and *0*.

**domain\_name**

A quoted string which is used as a DNS name; for example: *my.test.domain*.

**duration**

A duration in BIND 9 can be written in three ways: as a single number representing seconds, as a string of numbers with TTL-style time-unit suffixes, or in ISO 6801 duration format.

Allowed TTL time-unit suffixes are: "W" (week), "D" (day), "H" (hour), "M" (minute), and "S" (second). Examples: "1W" (1 week), "3d12h" (3 days, 12 hours).

ISO 8601 duration format consists of the letter "P", followed by an optional series of numbers with unit suffixes "Y" (year), "M" (month), "W" (week), and "D" (day); this may optionally be followed by the letter "T", and another series of numbers with unit suffixes "H" (hour), "M" (minute), and "S" (second). Examples: "P3M10D" (3 months, 10 days), "P2WT12H" (2 weeks, 12 hours), "pt15m" (15 minutes). For more information on ISO 8601 duration format, see [RFC 3339](#), appendix A.

Both TTL-style and ISO 8601 duration formats are case-insensitive.

**fixedpoint**

A non-negative real number that can be specified to the nearest one-hundredth. Up to five digits can be specified before a decimal point, and up to two digits after, so the maximum value is 99999.99. Acceptable values might be further limited by the contexts in which they are used.

**integer**

A non-negative 32-bit integer (i.e., a number between 0 and 4294967295, inclusive). Its acceptable value might be further limited by the context in which it is used.

**ip\_address**

An *ipv4\_address* or *ipv6\_address*.

**ipv4\_address**

An IPv4 address with exactly four integer elements valued 0 through 255 and separated by dots (.), such as 192.168.1.1 (a "dotted-decimal" notation with all four elements present).

**ipv6\_address**

An IPv6 address, such as 2001:db8::1234. IPv6-scoped addresses that have ambiguity on their scope zones must be disambiguated by an appropriate zone ID with the percent character (%) as a delimiter. It is strongly recommended to use string zone names rather than numeric identifiers, to be robust against system configuration changes. However, since there is no standard mapping for such names and identifier values, only interface names as link identifiers are supported, assuming one-to-one mapping between interfaces and links. For example, a link-local address fe80::1 on the link attached to the interface ne0 can be specified as fe80::1%ne0. Note that on most systems link-local addresses always have ambiguity and need to be disambiguated.

**netprefix**

An IP network specified as an *ip\_address*, followed by a slash (/) and then the number of bits in the netmask. Trailing zeros in an *ip\_address* may be omitted. For example, 127/8 is the network 127.0.0.0 with netmask 255.0.0.0 and 1.2.3.0/28 is network 1.2.3.0 with netmask 255.255.255.240. When specifying a prefix involving an IPv6-scoped address, the scope may be omitted. In that case, the prefix matches packets from any scope.

**percentage**

An integer value followed by % to represent percent.

**port**

An IP port *integer*. It is limited to 0 through 65535, with values below 1024 typically restricted to use by processes running as root. In some cases, an asterisk (\*) character can be used as a placeholder to select a random high-numbered port.

**portrange**

A list of a *port* or a port range. A port range is specified in the form of *range* followed by two *port*s, *port\_low* and *port\_high*, which represents port numbers from *port\_low* through *port\_high*, inclusive. *port\_low* must not be larger than *port\_high*. For example, *range* 1024 65535 represents ports from 1024 through 65535. The asterisk (\*) character is not allowed as a valid *port* or as a port range boundary.

**remote-servers**

A named list of one or more *ip\_address* es with optional *tls\_id*, *server\_key*, and/or *port*. A *remote-servers* list may include other *remote-servers* lists. See *primaries* block.

**server\_key**

A *domain\_name* representing the name of a shared key, to be used for *transaction security*. Keys are defined using *key* blocks.

**size**

**sizeval**

A 64-bit unsigned integer. Integers may take values  $0 \leq \text{value} \leq 18446744073709551615$ , though certain parameters (such as *max-journal-size*) may use a more limited range within these extremes. In most cases, setting a value to 0 does not literally mean zero; it means "undefined" or "as big as possible," depending on the context. See the explanations of particular parameters that use *size* for details on how they interpret its use. Numeric values can optionally be followed by a scaling factor: *K* or *k* for kilobytes, *M* or *m* for megabytes, and *G* or *g* for gigabytes, which scale by 1024, 1024\*1024, and 1024\*1024\*1024 respectively.

Some statements also accept the keywords *unlimited* or *default*: *unlimited* generally means "as big as possible," and is usually the best way to safely set a very large number. *default* uses the limit that was in force when the server was started.

**tls\_id**

A named TLS configuration object which defines a TLS key and certificate. See *tls* block.

## 8.2 Blocks

A BIND 9 configuration consists of blocks, statements, and comments.

The following blocks are supported:

*acl*

Defines a named IP address matching list, for access control and other uses.

*controls*

Declares control channels to be used by the *rndc* utility.

*dnssec-policy*

Describes a DNSSEC key and signing policy for zones. See *dnssec-policy* for details.

*key*

Specifies key information for use in authentication and authorization using TSIG.

*logging*

Specifies what information the server logs and where the log messages are sent.

**masters**

Synonym for *primaries*.

*options*

Controls global server configuration options and sets defaults for other statements.

*parental-agents*

Defines a named list of servers for inclusion in primary and secondary zones' *parental-agents* lists.

*primaries*

Defines a named list of servers for inclusion in stub and secondary zones' *primaries* or *also-notify* lists. (Note: this is a synonym for the original keyword *masters*, which can still be used, but is no longer the preferred terminology.)

*server*

Sets certain configuration options on a per-server basis.

***statistics-channels***

Declares communication channels to get access to *named* statistics.

***tls***

Specifies configuration information for a TLS connection, including a *key-file*, *cert-file*, *ca-file*, *dhparam-file*, *remote-hostname*, *ciphers*, *protocols*, *prefer-server-ciphers*, and *session-tickets*.

***http***

Specifies configuration information for an HTTP connection, including *endpoints*, *listener-clients*, and *streams-per-connection*.

***trust-anchors***

Defines DNSSEC trust anchors: if used with the *initial-key* or *initial-ds* keyword, trust anchors are kept up-to-date using **RFC 5011** trust anchor maintenance; if used with *static-key* or *static-ds*, keys are permanent.

***managed-keys***

Is identical to *trust-anchors*; this option is deprecated in favor of *trust-anchors* with the *initial-key* keyword, and may be removed in a future release.

***trusted-keys***

Defines permanent trusted DNSSEC keys; this option is deprecated in favor of *trust-anchors* with the *static-key* keyword, and may be removed in a future release.

***view***

Defines a view.

***zone***

Defines a zone.

The *logging* and *options* statements may only occur once per configuration.

## 8.2.1 *acl* Block Grammar

***acl***

**Grammar:** *acl* <string> { <address\_match\_element>; ... }; // may occur multiple times

**Blocks:** *topmost*

**Tags:** *server*

Assigns a symbolic name to an address match list.

## 8.2.2 *acl* Block Definition and Usage

The *acl* statement assigns a symbolic name to an address match list. It gets its name from one of the primary uses of address match lists: Access Control Lists (ACLs).

The following ACLs are built-in:

***any***

Matches all hosts.

***none***

Matches no hosts.

***localhost***

Matches the IPv4 and IPv6 addresses of all network interfaces on the system. When addresses are added or removed, the *localhost* ACL element is updated to reflect the changes.

**localnets**

Matches any host on an IPv4 or IPv6 network for which the system has an interface. When addresses are added or removed, the `localnets` ACL element is updated to reflect the changes. Some systems do not provide a way to determine the prefix lengths of local IPv6 addresses; in such cases, `localnets` only matches the local IPv6 addresses, just like `localhost`.

**8.2.3 *controls* Block Grammar****controls****Grammar:**

```
controls {
    inet ( <ipv4_address> | <ipv6_address> | * ) [ port ( <integer> | * ) ]
    ↪allow { <address_match_element>; ... } [ keys { <string>; ... } ] [ read-only
    ↪<boolean> ]; // may occur multiple times
    unix <quoted_string> perm <integer> owner <integer> group <integer> [
    ↪keys { <string>; ... } ] [ read-only <boolean> ]; // may occur multiple times
}; // may occur multiple times
```

**Blocks:** topmost

**Tags:** server

Specifies control channels to be used to manage the name server.

**8.2.4 *controls* Block Definition and Usage**

The `controls` statement declares control channels to be used by system administrators to manage the operation of the name server. These control channels are used by the `rndc` utility to send commands to and retrieve non-DNS results from a name server.

**unix**

**Grammar:** `unix <quoted_string> perm <integer> owner <integer> group <integer> [ keys { <string>; ... } ] [ read-only <boolean> ]; // may occur multiple times`

**Blocks:** controls

**Tags:** server

Specifies a Unix domain socket as a control channel.

A `unix` control channel is a Unix domain socket listening at the specified path in the file system. Access to the socket is specified by the `perm`, `owner`, and `group` clauses. Note that on some platforms (SunOS and Solaris), the permissions (`perm`) are applied to the parent directory as the permissions on the socket itself are ignored.

**inet**

**Grammar controls:** `inet ( <ipv4_address> | <ipv6_address> | * ) [ port ( <integer> | * ) ] allow { <address_match_element>; ... } [ keys { <string>; ... } ] [ read-only <boolean> ]; // may occur multiple times`

**Grammar statistics-channels:** `inet ( <ipv4_address> | <ipv6_address> | * ) [ port ( <integer> | * ) ] [ allow { <address_match_element>; ... } ]; // may occur multiple times`

**Blocks:** controls, statistics-channels

**Tags:** server

Specifies a TCP socket as a control channel.

An *inet* control channel is a TCP socket listening at the specified *port* on the specified *ip\_address*, which can be an IPv4 or IPv6 address. An *ip\_address* of \* (asterisk) is interpreted as the IPv4 wildcard address; connections are accepted on any of the system's IPv4 addresses. To listen on the IPv6 wildcard address, use an *ip\_address* of ::. If *rndc* is only used on the local host, using the loopback address (127.0.0.1 or ::1) is recommended for maximum security.

If no port is specified, port 953 is used. The asterisk \* cannot be used for *port*.

The ability to issue commands over the control channel is restricted by the *allow* and *keys* clauses.

**allow**

Connections to the control channel are permitted based on the *address\_match\_list*. This is for simple IP address-based filtering only; any *server\_key* elements of the *address\_match\_list* are ignored.

**keys**

The primary authorization mechanism of the command channel is the list of *server\_key*s. Each listed *key* is authorized to execute commands over the control channel. See *Administrative Tools* for information about configuring keys in *rndc*.

**read-only**

If the *read-only* argument is on, the control channel is limited to the following set of read-only commands: *nta-dump*, *null*, *status*, *showzone*, *testgen*, and *zonestatus*. By default, *read-only* is not enabled and the control channel allows read-write access.

If no *controls* statement is present, *named* sets up a default control channel listening on the loopback address 127.0.0.1 and its IPv6 counterpart, ::1. In this case, and also when the *controls* statement is present but does not have a *keys* clause, *named* attempts to load the command channel key from the file */usr/local/etc/rndc.key*. To create an *rndc.key* file, run *rndc-confgen -a*.

To disable the command channel, use an empty *controls* statement: `controls { };`

### 8.2.5 key Block Grammar

**key**

**Grammar:**

```
key <string> {
    algorithm <string>;
    secret <string>;
}; // may occur multiple times
```

**Blocks:** topmost, view

**Tags:** security

Defines a shared secret key for use with *TSIG* or the command channel.

### 8.2.6 key Block Definition and Usage

The *key* statement defines a shared secret key for use with *TSIG* (see *TSIG*) or the command channel (see *controls*).

The *key* statement can occur at the top level of the configuration file or inside a *view* statement. Keys defined in top-level *key* statements can be used in all views. Keys intended for use in a *controls* statement must be defined at the top level.

The *server\_key*, also known as the key name, is a domain name that uniquely identifies the key. It can be used in a *server* statement to cause requests sent to that server to be signed with this key, or in address match lists to verify that incoming requests have been signed with a key matching this name, algorithm, and secret.

**algorithm**

**Grammar:** `algorithm <string>;`

**Blocks:** key, view.key

**Tags:** security

Defines the algorithm to be used in a key clause.

The *algorithm\_id* is a string that specifies a security/authentication algorithm. The *named* server supports `hmac-md5`, `hmac-sha1`, `hmac-sha224`, `hmac-sha256`, `hmac-sha384`, and `hmac-sha512` TSIG authentication. Truncated hashes are supported by appending the minimum number of required bits preceded by a dash, e.g., `hmac-sha1-80`.

**secret**

**Grammar:** `secret <string>;`

**Blocks:** key, view.key

**Tags:** security

Defines a Base64-encoded string to be used as the secret by the algorithm.

The *secret\_string* is the secret to be used by the algorithm, and is treated as a Base64-encoded string.

## 8.2.7 logging Block Grammar

**logging**

**Grammar:**

```
logging {
    category <string> { <string>; ... }; // may occur multiple times
    channel <string> {
        buffered <boolean>;
        file <quoted_string> [ versions ( unlimited | <integer> ) ] [ ↵
↵size <size> ] [ suffix ( increment | timestamp ) ];
        null;
        print-category <boolean>;
        print-severity <boolean>;
        print-time ( iso8601 | iso8601-utc | local | <boolean> );
        severity <log_severity>;
        stderr;
        syslog [ <syslog_facility> ];
    }; // may occur multiple times
};
```

**Blocks:** topmost

**Tags:** logging

Configures logging options for the name server.

## 8.2.8 *logging* Block Definition and Usage

The *logging* statement configures a wide variety of logging options for the name server. Its *channel* phrase associates output methods, format options, and severity levels with a name that can then be used with the *category* phrase to select how various classes of messages are logged.

Only one *logging* statement is used to define as many channels and categories as desired. If there is no *logging* statement, the logging configuration is:

```
logging {
    category default { default_syslog; default_debug; };
    category unmatched { null; };
};
```

If *named* is started with the *-L* option, it logs to the specified file at startup, instead of using syslog. In this case the logging configuration is:

```
logging {
    category default { default_logfile; default_debug; };
    category unmatched { null; };
};
```

The logging configuration is only established when the entire configuration file has been parsed. When the server starts up, all logging messages regarding syntax errors in the configuration file go to the default channels, or to standard error if the *-g* option was specified.

### The *channel* Phrase

#### **channel**

##### **Grammar:**

```
channel <string> {
    buffered <boolean>;
    file <quoted_string> [ versions ( unlimited | <integer> ) ] [ size <size>_L
↔] [ suffix ( increment | timestamp ) ];
    null;
    print-category <boolean>;
    print-severity <boolean>;
    print-time ( iso8601 | iso8601-utc | local | <boolean> );
    severity <log_severity>;
    stderr;
    syslog [ <syslog_facility> ];
}; // may occur multiple times
```

**Blocks:** logging

**Tags:** logging

Defines a stream of data that can be independently logged.

All log output goes to one or more *channels*; there is no limit to the number of channels that can be created.

Every channel definition must include a destination clause that says whether messages selected for the channel go to a file, go to a particular syslog facility, go to the standard error stream, or are discarded. The definition can optionally also limit the message severity level that is accepted by the channel (the default is *info*), and whether to include a *named*-generated time stamp, the category name, and/or the severity level (the default is not to include any).

**null**

**Grammar:** `null;`

**Blocks:** `logging.channel`

**Tags:** `logging`

Causes all messages sent to the logging channel to be discarded.

The `null` destination clause causes all messages sent to the channel to be discarded; in that case, other options for the channel are meaningless.

**file**

The `file` destination clause directs the channel to a disk file. It can include additional arguments to specify how large the file is allowed to become before it is rolled to a backup file (`size`), how many backup versions of the file are saved each time this happens (`versions`), and the format to use for naming backup versions (`suffix`).

The `size` option is used to limit log file growth. If the file ever exceeds the specified size, then `named` stops writing to the file unless it has a `versions` option associated with it. If backup versions are kept, the files are rolled as described below. If there is no `versions` option, no more data is written to the log until some out-of-band mechanism removes or truncates the log to less than the maximum size. The default behavior is not to limit the size of the file.

File rolling only occurs when the file exceeds the size specified with the `size` option. No backup versions are kept by default; any existing log file is simply appended. The `versions` option specifies how many backup versions of the file should be kept. If set to `unlimited`, there is no limit.

The `suffix` option can be set to either `increment` or `timestamp`. If set to `timestamp`, then when a log file is rolled, it is saved with the current timestamp as a file suffix. If set to `increment`, then backup files are saved with incrementing numbers as suffixes; older files are renamed when rolling. For example, if `versions` is set to 3 and `suffix` to `increment`, then when `filename.log` reaches the size specified by `size`, `filename.log.1` is renamed to `filename.log.2`, `filename.log.0` is renamed to `filename.log.1`, and `filename.log` is renamed to `filename.log.0`, whereupon a new `filename.log` is opened.

Here is an example using the `size`, `versions`, and `suffix` options:

```
channel an_example_channel {
    file "example.log" versions 3 size 20m suffix increment;
    print-time yes;
    print-category yes;
};
```

**syslog**

**Grammar:** `syslog [ <syslog_facility> ];`

**Blocks:** `logging.channel`

**Tags:** `logging`

Directs the logging channel to the system log.

The `syslog` destination clause directs the channel to the system log. Its argument is a syslog facility as described in the `syslog` man page. Known facilities are `kern`, `user`, `mail`, `daemon`, `auth`, `syslog`, `lpr`, `news`, `uucp`, `cron`, `authpriv`, `ftp`, `local0`, `local1`, `local2`, `local3`, `local4`, `local5`, `local6`, and `local7`; however, not all facilities are supported on all operating systems. How `syslog` handles messages sent to this facility is described in the `syslog.conf` man page. On a system which uses a very old version of `syslog`, which only uses two arguments to the `openlog()` function, this clause is silently ignored.

**severity****Grammar:** `severity <log_severity>;`**Blocks:** `logging.channel`**Tags:** `logging`

Defines the priority level of log messages.

The `severity` clause works like `syslog`'s "priorities," except that they can also be used when writing straight to a file rather than using `syslog`. Messages which are not at least of the severity level given are not selected for the channel; messages of higher severity levels are accepted.

When using `syslog`, the `syslog.conf` priorities also determine what eventually passes through. For example, defining a channel facility and severity as `daemon` and `debug`, but only logging `daemon.warning` via `syslog.conf`, causes messages of severity `info` and `notice` to be dropped. If the situation were reversed, with `named` writing messages of only `warning` or higher, then `syslogd` would print all messages it received from the channel.

**stderr****Grammar:** `stderr;`**Blocks:** `logging.channel`**Tags:** `logging`

Directs the logging channel output to the server's standard error stream.

The `stderr` destination clause directs the channel to the server's standard error stream. This is intended for use when the server is running as a foreground process, as when debugging a configuration, for example.

The server can supply extensive debugging information when it is in debugging mode. If the server's global debug level is greater than zero, debugging mode is active. The global debug level is set either by starting the `named` server with the `-d` flag followed by a positive integer, or by running `rndc trace`. The global debug level can be set to zero, and debugging mode turned off, by running `rndc notrace`. All debugging messages in the server have a debug level; higher debug levels give more detailed output. Channels that specify a specific debug severity, for example:

```
channel specific_debug_level {
    file "foo";
    severity debug 3;
};
```

get debugging output of level 3 or less any time the server is in debugging mode, regardless of the global debugging level. Channels with `dynamic` severity use the server's global debug level to determine what messages to print.

**print-time****Grammar:** `print-time ( iso8601 | iso8601-utc | local | <boolean> );`**Blocks:** `logging.channel`**Tags:** `logging`

Specifies the time format for log messages.

`print-time` can be set to `yes`, `no`, or a time format specifier, which may be one of `local`, `iso8601`, or `iso8601-utc`. If set to `no`, the date and time are not logged. If set to `yes` or `local`, the date and time are logged in a human-readable format, using the local time zone. If set to `iso8601`, the local time is logged in ISO

8601 format. If set to `iso8601-utc`, the date and time are logged in ISO 8601 format, with time zone set to UTC. The default is `no`.

`print-time` may be specified for a `syslog` channel, but it is usually pointless since `syslog` also logs the date and time.

**print-category**

**Grammar:** `print-category <boolean>;`

**Blocks:** `logging.channel`

**Tags:** `logging`

Includes the category in log messages.

If `print-category` is requested, then the category of the message is logged as well.

**print-severity**

**Grammar:** `print-severity <boolean>;`

**Blocks:** `logging.channel`

**Tags:** `logging`

Includes the severity in log messages.

If `print-severity` is on, then the severity level of the message is logged. The `print-` options may be used in any combination, and are always printed in the following order: time, category, severity.

Here is an example where all three `print-` options are on:

```
28-Feb-2000 15:05:32.863 general: notice: running
```

**buffered**

**Grammar:** `buffered <boolean>;`

**Blocks:** `logging.channel`

**Tags:** `logging`

Controls flushing of log messages.

If `buffered` has been turned on, the output to files is not flushed after each log entry. By default all log messages are flushed.

There are four predefined channels that are used for `named`'s default logging, as follows. If `named` is started with the `-L` option, then a fifth channel, `default_logfile`, is added. How they are used is described in `category`.

```
channel default_syslog {
    // send to syslog's daemon facility
    syslog daemon;
    // only send priority info and higher
    severity info;
};

channel default_debug {
    // write to named.run in the working directory
    // Note: stderr is used instead of "named.run" if
```

(continues on next page)

(continued from previous page)

```

// the server is started with the '-g' option.
file "named.run";
// log at the server's current debug level
severity dynamic;
};

channel default_stderr {
    // writes to stderr
    stderr;
    // only send priority info and higher
    severity info;
};

channel null {
    // toss anything sent to this channel
    null;
};

channel default_logfile {
    // this channel is only present if named is
    // started with the -L option, whose argument
    // provides the file name
    file "...";
    // log at the server's current debug level
    severity dynamic;
};

```

The `default_debug` channel has the special property that it only produces output when the server's debug level is non-zero. It normally writes to a file called `named.run` in the server's working directory.

For security reasons, when the `-u` command-line option is used, the `named.run` file is created only after `named` has changed to the new UID, and any debug output generated while `named` is starting - and still running as root - is discarded. To capture this output, run the server with the `-L` option to specify a default logfile, or the `-g` option to log to standard error which can be redirected to a file.

Once a channel is defined, it cannot be redefined. The built-in channels cannot be altered directly, but the default logging can be modified by pointing categories at defined channels.

### The *category* Phrase

There are many categories, so desired logs can be sent anywhere while unwanted logs are ignored. If a list of channels is not specified for a category, log messages in that category are sent to the `default` category instead. If no default category is specified, the following "default default" is used:

```
category default { default_syslog; default_debug; };
```

If `named` is started with the `-L` option, the default category is:

```
category default { default_logfile; default_debug; };
```

As an example, let's say a user wants to log security events to a file, but also wants to keep the default logging behavior. They would specify the following:

```
channel my_security_channel {
    file "my_security_file";
    severity info;
};
category security {
    my_security_channel;
    default_syslog;
    default_debug;
};
```

To discard all messages in a category, specify the *null* channel:

```
category xfer-out { null; };
category notify { null; };
```

**category**

**Grammar:** category <string> { <string>; ... }; // may occur multiple times

**Blocks:** logging

**Tags:** logging

Specifies the type of data logged to a particular channel.

The following are the available categories and brief descriptions of the types of log information they contain. More categories may be added in future BIND releases.

**client**

Processing of client requests.

**cname**

Name servers that are skipped for being a CNAME rather than A/AAAA records.

**config**

Configuration file parsing and processing.

**database**

Messages relating to the databases used internally by the name server to store zone and cache data.

**default**

Logging options for those categories where no specific configuration has been defined.

**delegation-only**

Queries that have been forced to NXDOMAIN as the result of a delegation-only zone or a *delegation-only* in a forward, hint, or stub zone declaration.

**dispatch**

Dispatching of incoming packets to the server modules where they are to be processed.

**dnssec**

DNSSEC and TSIG protocol processing.

**dnstap**

The *dnstap* DNS traffic capture system.

**edns-disabled**

Log queries that have been forced to use plain DNS due to timeouts. This is often due to the remote servers not being **RFC 1034**-compliant (not always returning FORMERR or similar to EDNS queries and other extensions)

to the DNS when they are not understood). In other words, this is targeted at servers that fail to respond to DNS queries that they don't understand.

Note: the log message can also be due to packet loss. Before reporting servers for non-**RFC 1034** compliance they should be re-tested to determine the nature of the non-compliance. This testing should prevent or reduce the number of false-positive reports.

Note: eventually *named* will have to stop treating such timeouts as due to **RFC 1034** non-compliance and start treating it as plain packet loss. Falsely classifying packet loss as due to **RFC 1034** non-compliance impacts DNSSEC validation, which requires EDNS for the DNSSEC records to be returned.

#### **general**

A catch-all for many things that still are not classified into categories.

#### **lame-servers**

Misconfigurations in remote servers, discovered by BIND 9 when trying to query those servers during resolution.

#### **network**

Network operations.

#### **notify**

The NOTIFY protocol.

#### **nsid**

NSID options received from upstream servers.

#### **queries**

A location where queries should be logged.

At startup, specifying the category *queries* also enables query logging unless the *querylog* option has been specified.

The query log entry first reports a client object identifier in @0x<hexadecimal-number> format. Next, it reports the client's IP address and port number, and the query name, class, and type. Next, it reports whether the Recursion Desired flag was set (+ if set, - if not set), whether the query was signed (S), whether EDNS was in use along with the EDNS version number (E(#)), whether TCP was used (T), whether DO (DNSSEC Ok) was set (D), whether CD (Checking Disabled) was set (C), whether a valid DNS Server COOKIE was received (V), and whether a DNS COOKIE option without a valid Server COOKIE was present (K). After this, the destination address the query was sent to is reported. Finally, if any CLIENT-SUBNET option was present in the client query, it is included in square brackets in the format [ECS address/source/scope].

```
client @0x7f91b8005490 127.0.0.1#62536 (www.example.com): query: www.example.com.
↳IN AAAA +E(0)K (127.0.0.1)
client @0x7f91b4007400 ::1#62537 (www.example.net): query: www.example.net IN.
↳AAAA +E(0)K (::1)
```

The first part of this log message, showing the client address/port number and query name, is repeated in all subsequent log messages related to the same query.

#### **query-errors**

Information about queries that resulted in some failure.

#### **rate-limit**

Start, periodic, and final notices of the rate limiting of a stream of responses that are logged at *info* severity in this category. These messages include a hash value of the domain name of the response and the name itself, except when there is insufficient memory to record the name for the final notice. The final notice is normally delayed until about one minute after rate limiting stops. A lack of memory can hurry the final notice, which is indicated by an initial asterisk (\*). Various internal events are logged at debug level 1 and higher.

Rate limiting of individual requests is logged in the *query-errors* category.

**resolver**

DNS resolution, such as the recursive lookups performed on behalf of clients by a caching name server.

**rpz**

Information about errors in response policy zone files, rewritten responses, and, at the highest `debug` levels, mere rewriting attempts.

**rpz-passthru**

Information about RPZ PASSTHRU policy activity. This category allows pre-approved policy activity to be logged into a dedicated channel.

**security**

Approval and denial of requests.

**serve-stale**

Indication of whether a stale answer is used following a resolver failure.

**spill**

Queries that have been terminated, either by dropping or responding with SERVFAIL, as a result of a `fetchlimit` quota being exceeded.

**sslkeylog**

TLS pre-master secrets (for debugging purposes).

**trust-anchor-telemetry**

*trust-anchor-telemetry* requests received by *named*.

**unmatched**

Messages that *named* was unable to determine the class of, or for which there was no matching *view*. A one-line summary is also logged to the `client` category. This category is best sent to a file or `stderr`; by default it is sent to the *null* channel.

**update**

Dynamic updates.

**update-security**

Approval and denial of update requests.

**xfer-in**

Zone transfers the server is receiving.

**xfer-out**

Zone transfers the server is sending.

**zoneload**

Loading of zones and creation of automatic empty zones.

**The query-errors Category**

The `query-errors` category is used to indicate why and how specific queries resulted in responses which indicate an error. Normally, these messages are logged at `debug` logging levels; note, however, that if query logging is active, some are logged at `info`. The logging levels are described below:

At `debug` level 1 or higher - or at `info` when query logging is active - each response with the rcode of SERVFAIL is logged as follows:

```
client 127.0.0.1#61502: query failed (SERVFAIL) for www.example.com/IN/AAAA at query.  
c:3880
```

This means an error resulting in SERVFAIL was detected at line 3880 of source file `query.c`. Log messages of this level are particularly helpful in identifying the cause of SERVFAIL for an authoritative server.

At debug level 2 or higher, detailed context information about recursive resolutions that resulted in SERVFAIL is logged. The log message looks like this:

```
fetch completed at resolver.c:2970 for www.example.com/A
in 10.000183: timed out/success [domain:example.com,
referral:2,restart:7,qrysent:8,timeout:5,lame:0,quota:0,neterr:0,
badresp:1,adberr:0,findfail:0,valfail:0]
```

The first part before the colon shows that a recursive resolution for AAAA records of `www.example.com` completed in 10.000183 seconds, and the final result that led to the SERVFAIL was determined at line 2970 of source file `resolver.c`.

The next part shows the detected final result and the latest result of DNSSEC validation. The latter is always "success" when no validation attempt was made. In this example, this query probably resulted in SERVFAIL because all name servers are down or unreachable, leading to a timeout in 10 seconds. DNSSEC validation was probably not attempted.

The last part, enclosed in square brackets, shows statistics collected for this particular resolution attempt. The `domain` field shows the deepest zone that the resolver reached; it is the zone where the error was finally detected. The meaning of the other fields is summarized in the following list.

**referral**

The number of referrals the resolver received throughout the resolution process. In the above `example.com` there are two.

**restart**

The number of cycles that the resolver tried remote servers at the `domain` zone. In each cycle, the resolver sends one query (possibly resending it, depending on the response) to each known name server of the `domain` zone.

**qrysent**

The number of queries the resolver sent at the `domain` zone.

**timeout**

The number of timeouts the resolver received since the last response.

**lame**

The number of lame servers the resolver detected at the `domain` zone. A server is detected to be lame either by an invalid response or as a result of lookup in BIND 9's address database (ADB), where lame servers are cached.

**quota**

The number of times the resolver was unable to send a query because it had exceeded the permissible fetch quota for a server.

**neterr**

The number of erroneous results that the resolver encountered in sending queries at the `domain` zone. One common case is when the remote server is unreachable and the resolver receives an "ICMP unreachable" error message.

**badresp**

The number of unexpected responses (other than `lame`) to queries sent by the resolver at the `domain` zone.

**adberr**

Failures in finding remote server addresses of the ``domain`` zone in the ADB. One common case of this is that the remote server's name does not have any address records.

**findfail**

Failures to resolve remote server addresses. This is a total number of failures throughout the resolution process.

**valfail**

Failures of DNSSEC validation. Validation failures are counted throughout the resolution process (not limited to the `domain` zone), but should only happen in `domain`.

At debug level 3 or higher, the same messages as those at debug level 1 are logged for errors other than SERVFAIL. Note that negative responses such as NXDOMAIN are not errors, and are not logged at this debug level.

At debug level 4 or higher, the detailed context information logged at debug level 2 is logged for errors other than SERVFAIL and for negative responses such as NXDOMAIN.

## 8.2.9 *parental-agents* Block Grammar

### **parental-agents**

**Grammar zone (primary, secondary):** `parental-agents [ port <integer> ] { ( <remote-servers> | <ipv4_address> [ port <integer> ] | <ipv6_address> [ port <integer> ] ) [ key <string> ] [ tls <string> ]; ... };`

**Grammar topmost:** `parental-agents <string> [ port <integer> ] { ( <remote-servers> | <ipv4_address> [ port <integer> ] | <ipv6_address> [ port <integer> ] ) [ key <string> ] [ tls <string> ]; ... }; // may occur multiple times`

**Blocks:** topmost, zone (primary, secondary)

**Tags:** zone

Defines a list of delegation agents to be used by primary and secondary zones.

## 8.2.10 *parental-agents* Block Definition and Usage

*parental-agents* lists allow for a common set of parental agents to be easily used by multiple primary and secondary zones. A "parental agent" is a trusted DNS server that is queried to check whether DS records for a given zones are up-to-date.

## 8.2.11 *primaries* Block Grammar

### **primaries**

**Grammar zone (mirror, redirect, secondary, stub):** `primaries [ port <integer> ] { ( <remote-servers> | <ipv4_address> [ port <integer> ] | <ipv6_address> [ port <integer> ] ) [ key <string> ] [ tls <string> ]; ... };`

**Grammar topmost:** `primaries <string> [ port <integer> ] { ( <remote-servers> | <ipv4_address> [ port <integer> ] | <ipv6_address> [ port <integer> ] ) [ key <string> ] [ tls <string> ]; ... }; // may occur multiple times`

**Blocks:** topmost, zone (mirror, redirect, secondary, stub)

**Tags:** zone

Defines one or more primary servers for a zone.

## 8.2.12 *primaries* Block Definition and Usage

*primaries* lists allow for a common set of primary servers to be easily used by multiple stub and secondary zones in their *primaries* or *also-notify* lists. (Note: *primaries* is a synonym for the original keyword *masters*, which can still be used, but is no longer the preferred terminology.)

To force the zone transfer requests to be sent over TLS, use *tls* keyword, e.g. `primaries { 192.0.2.1 tls tls-configuration-name; };`, where *tls-configuration-name* refers to a previously defined *tls statement*.

**Warning**

Please note that TLS connections to primaries are **not authenticated** unless `remote-hostname` or `ca-file` are specified within the `tls statement` in use (see information on *Strict TLS* and *Mutual TLS* for more details). **Not authenticated mode** (*Opportunistic TLS*) provides protection from passive observers but does not protect from man-in-the-middle attacks on zone transfers.

**Warning**

Please note that this version of BIND 9 does not support dynamic update forwarding (see *allow-update-forwarding*) in conjunction with zone transfers over TLS (XoT). This includes when the `tls` keyword is used with `primaries`, e.g. `primaries { 192.0.2.1 tls tls-configuration-name; };`

## 8.2.13 options Block Grammar

### options

**Grammar:**

```
options {
    allow-new-zones <boolean>;
    allow-notify { <address_match_element>; ... };
    allow-query { <address_match_element>; ... };
    allow-query-cache { <address_match_element>; ... };
    allow-query-cache-on { <address_match_element>; ... };
    allow-query-on { <address_match_element>; ... };
    allow-recursion { <address_match_element>; ... };
    allow-recursion-on { <address_match_element>; ... };
    allow-transfer [ port <integer> ] [ transport <string> ] { <address_match_
↳element>; ... };
    allow-update { <address_match_element>; ... };
    allow-update-forwarding { <address_match_element>; ... };
    also-notify [ port <integer> ] { ( <remote-servers> | <ipv4_address> [ _
↳port <integer> ] | <ipv6_address> [ port <integer> ] ) [ key <string> ] [ tls
↳<string> ]; ... };
    alt-transfer-source ( <ipv4_address> | * ); // deprecated
    alt-transfer-source-v6 ( <ipv6_address> | * ); // deprecated
    answer-cookie <boolean>;
    attach-cache <string>;
    auth-nxdomain <boolean>;
    auto-dnssec ( allow | maintain | off ); // deprecated
    automatic-interface-scan <boolean>;
    avoid-v4-udp-ports { <portrange>; ... }; // deprecated
    avoid-v6-udp-ports { <portrange>; ... }; // deprecated
    bindkeys-file <quoted_string>;
    blackhole { <address_match_element>; ... };
    catalog-zones { zone <string> [ default-primaries [ port <integer> ] { (
↳<remote-servers> | <ipv4_address> [ port <integer> ] | <ipv6_address> [ port
↳<integer> ] ) [ key <string> ] [ tls <string> ]; ... } ] [ zone-directory
↳<quoted_string> ] [ in-memory <boolean> ] [ min-update-interval <duration> ]; ..
↳. };

```

(continues on next page)

(continued from previous page)

```

check-dup-records ( fail | warn | ignore );
check-integrity <boolean>;
check-mx ( fail | warn | ignore );
check-mx-cname ( fail | warn | ignore );
check-names ( primary | master | secondary | slave | response ) ( fail | ↵
↵warn | ignore ); // may occur multiple times
check-sibling <boolean>;
check-spf ( warn | ignore );
check-srv-cname ( fail | warn | ignore );
check-wildcard <boolean>;
clients-per-query <integer>;
cookie-algorithm ( aes | siphash24 );
cookie-secret <string>; // may occur multiple times
coresize ( default | unlimited | <sizeval> ); // deprecated
datasize ( default | unlimited | <sizeval> ); // deprecated
deny-answer-addresses { <address_match_element>; ... } [ except-from {
↵<string>; ... } ];
deny-answer-aliases { <string>; ... } [ except-from { <string>; ... } ];
dialup ( notify | notify-passive | passive | refresh | <boolean> ); ↵
↵deprecated
directory <quoted_string>;
disable-algorithms <string> { <string>; ... }; // may occur multiple times
disable-ds-digests <string> { <string>; ... }; // may occur multiple times
disable-empty-zone <string>; // may occur multiple times
dns64 <netprefix> {
    break-dnssec <boolean>;
    clients { <address_match_element>; ... };
    exclude { <address_match_element>; ... };
    mapped { <address_match_element>; ... };
    recursive-only <boolean>;
    suffix <ipv6_address>;
}; // may occur multiple times
dns64-contact <string>;
dns64-server <string>;
dnskey-sig-validity <integer>;
dnssrps-enable <boolean>;
dnssrps-options { <unspecified-text> };
dnssec-accept-expired <boolean>;
dnssec-dnskey-kskonly <boolean>;
dnssec-loadkeys-interval <integer>;
dnssec-must-be-secure <string> <boolean>; // may occur multiple times, ↵
↵deprecated
dnssec-policy <string>;
dnssec-secure-to-insecure <boolean>;
dnssec-update-mode ( maintain | no-resign );
dnssec-validation ( yes | no | auto );
dnstap { ( all | auth | client | forwarder | resolver | update ) [ ( ↵
↵query | response ) ]; ... };
dnstap-identity ( <quoted_string> | none | hostname );
dnstap-output ( file | unix ) <quoted_string> [ size ( unlimited | <size> ↵
↵) ] [ versions ( unlimited | <integer> ) ] [ suffix ( increment | timestamp ) ];
dnstap-version ( <quoted_string> | none );

```

(continues on next page)

(continued from previous page)

```

    dscp <integer>; // obsolete
    dual-stack-servers [ port <integer> ] { ( <quoted_string> [ port <integer>
↪ ] | <ipv4_address> [ port <integer> ] | <ipv6_address> [ port <integer> ] ); ..
↪. };
    dump-file <quoted_string>;
    edns-udp-size <integer>;
    empty-contact <string>;
    empty-server <string>;
    empty-zones-enable <boolean>;
    fetch-quota-params <integer> <fixedpoint> <fixedpoint> <fixedpoint>;
    fetches-per-server <integer> [ ( drop | fail ) ];
    fetches-per-zone <integer> [ ( drop | fail ) ];
    files ( default | unlimited | <sizeval> ); // deprecated
    flush-zones-on-shutdown <boolean>;
    forward ( first | only );
    forwarders [ port <integer> ] { ( <ipv4_address> | <ipv6_address> ) [↪
↪port <integer> ]; ... };
    fstrm-set-buffer-hint <integer>;
    fstrm-set-flush-timeout <integer>;
    fstrm-set-input-queue-size <integer>;
    fstrm-set-output-notify-threshold <integer>;
    fstrm-set-output-queue-model ( mpsc | spsc );
    fstrm-set-output-queue-size <integer>;
    fstrm-set-reopen-interval <duration>;
    geoip-directory ( <quoted_string> | none );
    glue-cache <boolean>; // deprecated
    heartbeat-interval <integer>; // deprecated
    hostname ( <quoted_string> | none );
    http-listener-clients <integer>;
    http-port <integer>;
    http-streams-per-connection <integer>;
    https-port <integer>;
    interface-interval <duration>;
    ipv4only-contact <string>;
    ipv4only-enable <boolean>;
    ipv4only-server <string>;
    ixfr-from-differences ( primary | master | secondary | slave | <boolean>↪
↪);
    keep-response-order { <address_match_element>; ... };
    key-directory <quoted_string>;
    lame-ttl <duration>;
    listen-on [ port <integer> ] [ tls <string> ] [ http <string> ] {
↪<address_match_element>; ... }; // may occur multiple times
    listen-on-v6 [ port <integer> ] [ tls <string> ] [ http <string> ] {
↪<address_match_element>; ... }; // may occur multiple times
    lmbd-mapsize <sizeval>;
    lock-file ( <quoted_string> | none );
    managed-keys-directory <quoted_string>;
    masterfile-format ( raw | text );
    masterfile-style ( full | relative );
    match-mapped-addresses <boolean>;
    max-cache-size ( default | unlimited | <sizeval> | <percentage> );

```

(continues on next page)

(continued from previous page)

```
max-cache-ttl <duration>;
max-clients-per-query <integer>;
max-ixfr-ratio ( unlimited | <percentage> );
max-journal-size ( default | unlimited | <sizeval> );
max-ncache-ttl <duration>;
max-query-count <integer>;
max-query-restarts <integer>;
max-records <integer>;
max-records-per-type <integer>;
max-recursion-depth <integer>;
max-recursion-queries <integer>;
max-refresh-time <integer>;
max-retry-time <integer>;
max-rsa-exponent-size <integer>;
max-stale-ttl <duration>;
max-transfer-idle-in <integer>;
max-transfer-idle-out <integer>;
max-transfer-time-in <integer>;
max-transfer-time-out <integer>;
max-types-per-name <integer>;
max-udp-size <integer>;
max-zone-ttl ( unlimited | <duration> );
memstatistics <boolean>;
memstatistics-file <quoted_string>;
message-compression <boolean>;
min-cache-ttl <duration>;
min-ncache-ttl <duration>;
min-refresh-time <integer>;
min-retry-time <integer>;
minimal-any <boolean>;
minimal-responses ( no-auth | no-auth-recursive | <boolean> );
multi-master <boolean>;
new-zones-directory <quoted_string>;
no-case-compress { <address_match_element>; ... };
nocookie-udp-size <integer>;
notify ( explicit | master-only | primary-only | <boolean> );
notify-delay <integer>;
notify-rate <integer>;
notify-source ( <ipv4_address> | * );
notify-source-v6 ( <ipv6_address> | * );
notify-to-soa <boolean>;
nsec3-test-zone <boolean>; // test only
nta-lifetime <duration>;
nta-recheck <duration>;
nxdomain-redirect <string>;
parental-source ( <ipv4_address> | * );
parental-source-v6 ( <ipv6_address> | * );
pid-file ( <quoted_string> | none );
port <integer>;
preferred-glue <string>;
prefetch <integer> [ <integer> ];
provide-ixfr <boolean>;
```

(continues on next page)

(continued from previous page)

```

qname-minimization ( strict | relaxed | disabled | off );
query-source [ address ] ( <ipv4_address> | * );
query-source-v6 [ address ] ( <ipv6_address> | * );
querylog <boolean>;
random-device ( <quoted_string> | none ); // obsolete
rate-limit {
    all-per-second <integer>;
    errors-per-second <integer>;
    exempt-clients { <address_match_element>; ... };
    ipv4-prefix-length <integer>;
    ipv6-prefix-length <integer>;
    log-only <boolean>;
    max-table-size <integer>;
    min-table-size <integer>;
    nodata-per-second <integer>;
    nxdomains-per-second <integer>;
    qps-scale <integer>;
    referrals-per-second <integer>;
    responses-per-second <integer>;
    slip <integer>;
    window <integer>;
};
recursing-file <quoted_string>;
recursion <boolean>;
recursive-clients <integer>;
request-expire <boolean>;
request-ixfr <boolean>;
request-nsid <boolean>;
require-server-cookie <boolean>;
reserved-sockets <integer>; // deprecated
resolver-nonbackoff-tries <integer>; // deprecated
resolver-query-timeout <integer>;
resolver-retry-interval <integer>; // deprecated
response-padding { <address_match_element>; ... } block-size <integer>;
response-policy { zone <string> [ add-soa <boolean> ] [ log <boolean> ] [ ↵
↵max-policy-ttl <duration> ] [ min-update-interval <duration> ] [ policy ( cname ↵
↵| disabled | drop | given | no-op | nodata | nxdomain | passthru | tcp-only
↵<quoted_string> ) ] [ recursive-only <boolean> ] [ nsip-enable <boolean> ] [ ↵
↵nsdname-enable <boolean> ]; ... } [ add-soa <boolean> ] [ break-dnssec <boolean>
↵ ] [ max-policy-ttl <duration> ] [ min-update-interval <duration> ] [ min-ns-
↵dots <integer> ] [ nsip-wait-recurse <boolean> ] [ nsdname-wait-recurse
↵<boolean> ] [ qname-wait-recurse <boolean> ] [ recursive-only <boolean> ] [ ↵
↵nsip-enable <boolean> ] [ nsdname-enable <boolean> ] [ dnsrps-enable <boolean> ↵
↵] [ dnsrps-options { <unspecified-text> } ];
    reuseport <boolean>;
    root-delegation-only [ exclude { <string>; ... } ]; // deprecated
    root-key-sentinel <boolean>;
    rrset-order { [ class <string> ] [ type <string> ] [ name <quoted_string> ↵
↵] <string> <string>; ... };
    secroots-file <quoted_string>;
    send-cookie <boolean>;
    serial-query-rate <integer>;

```

(continues on next page)

(continued from previous page)

```
serial-update-method ( date | increment | unixtime );
server-id ( <quoted_string> | none | hostname );
servfail-ttl <duration>;
session-keyalg <string>;
session-keyfile ( <quoted_string> | none );
session-keyname <string>;
sig-signing-nodes <integer>;
sig-signing-signatures <integer>;
sig-signing-type <integer>;
sig-validity-interval <integer> [ <integer> ];
sortlist { <address_match_element>; ... };
stacksize ( default | unlimited | <sizeval> ); // deprecated
stale-answer-client-timeout ( disabled | off | <integer> );
stale-answer-enable <boolean>;
stale-answer-ttl <duration>;
stale-cache-enable <boolean>;
stale-refresh-time <duration>;
startup-notify-rate <integer>;
statistics-file <quoted_string>;
suppress-initial-notify <boolean>; // obsolete
synth-from-dnssec <boolean>;
tcp-advertised-timeout <integer>;
tcp-clients <integer>;
tcp-idle-timeout <integer>;
tcp-initial-timeout <integer>;
tcp-keepalive-timeout <integer>;
tcp-listen-queue <integer>;
tcp-receive-buffer <integer>;
tcp-send-buffer <integer>;
tkey-dhkey <quoted_string> <integer>; // deprecated
tkey-domain <quoted_string>; // deprecated
tkey-gssapi-credential <quoted_string>; // deprecated
tkey-gssapi-keytab <quoted_string>;
tls-port <integer>;
transfer-format ( many-answers | one-answer );
transfer-message-size <integer>;
transfer-source ( <ipv4_address> | * );
transfer-source-v6 ( <ipv6_address> | * );
transfers-in <integer>;
transfers-out <integer>;
transfers-per-ns <integer>;
trust-anchor-telemetry <boolean>;
try-tcp-refresh <boolean>;
udp-receive-buffer <integer>;
udp-send-buffer <integer>;
update-check-ksk <boolean>;
update-quota <integer>;
use-alt-transfer-source <boolean>; // deprecated
use-v4-udp-ports { <portrange>; ... }; // deprecated
use-v6-udp-ports { <portrange>; ... }; // deprecated
v6-bias <integer>;
validate-exception { <string>; ... };
```

(continues on next page)

(continued from previous page)

```

version ( <quoted_string> | none );
zero-no-soa-ttl <boolean>;
zero-no-soa-ttl-cache <boolean>;
zone-statistics ( full | terse | none | <boolean> );
};

```

**Blocks:** topmost**Tags:** server

Defines global options to be used by BIND 9.

This is the grammar of the `options` statement in the `named.conf` file:

### 8.2.14 `options` Block Definition and Usage

The `options` statement sets up global options to be used by BIND. This statement may appear only once in a configuration file. If there is no `options` statement, an options block with each option set to its default is used.

#### **attach-cache**

**Grammar:** `attach-cache <string>;`**Blocks:** options, view**Tags:** view

Allows multiple views to share a single cache database.

This option allows multiple views to share a single cache database. Each view has its own cache database by default, but if multiple views have the same operational policy for name resolution and caching, those views can share a single cache to save memory, and possibly improve resolution efficiency, by using this option.

The `attach-cache` option may also be specified in `view` statements, in which case it overrides the global `attach-cache` option.

The `cache_name` specifies the cache to be shared. When the `named` server configures views which are supposed to share a cache, it creates a cache with the specified name for the first view of these sharing views. The rest of the views simply refer to the already-created cache.

One common configuration to share a cache is to allow all views to share a single cache. This can be done by specifying `attach-cache` as a global option with an arbitrary name.

Another possible operation is to allow a subset of all views to share a cache while the others retain their own caches. For example, if there are three views A, B, and C, and only A and B should share a cache, specify the `attach-cache` option as a view of A (or B)'s option, referring to the other view name:

```

view "A" {
    // this view has its own cache
    ...
};
view "B" {
    // this view refers to A's cache
    attach-cache "A";
};
view "C" {

```

(continues on next page)

(continued from previous page)

```
// this view has its own cache
...
};
```

Views that share a cache must have the same policy on configurable parameters that may affect caching. The current implementation requires the following configurable options be consistent among these views: *check-names*, *dnssec-accept-expired*, *dnssec-validation*, *max-cache-ttl*, *max-ncache-ttl*, *max-stale-ttl*, *max-cache-size*, *min-cache-ttl*, *min-ncache-ttl*, and *zero-no-soa-ttl*.

Note that there may be other parameters that may cause confusion if they are inconsistent for different views that share a single cache. For example, if these views define different sets of forwarders that can return different answers for the same question, sharing the answer does not make sense or could even be harmful. It is the administrator's responsibility to ensure that configuration differences in different views do not cause disruption with a shared cache.

**directory**

**Grammar:** `directory <quoted_string>;`

**Blocks:** options

**Tags:** server

Sets the server's working directory.

This sets the working directory of the server. Any non-absolute pathnames in the configuration file are taken as relative to this directory. The default location for most server output files (e.g., `named.run`) is this directory. If a directory is not specified, the working directory defaults to ". ", the directory from which the server was started. The directory specified should be an absolute path, and *must* be writable by the effective user ID of the *named* process.

The option takes effect only at the time that the configuration option is parsed; if other files are being included before or after specifying the new *directory*, the *directory* option must be listed before any other directive (like `include`) that can work with relative files. The safest way to include files is to use absolute file names.

**dnstap**

**Grammar:** `dnstap { ( all | auth | client | forwarder | resolver | update ) [ ( query | response ) ]; ... };`

**Blocks:** options, view

**Tags:** logging

Enables logging of *dnstap* messages.

*dnstap* is a fast, flexible method for capturing and logging DNS traffic. Developed by Robert Edmonds at Farsight Security, Inc., and supported by multiple DNS implementations, *dnstap* uses `libfstrm` (a lightweight high-speed framing library; see <https://github.com/farsightsec/fstrm>) to send event payloads which are encoded using Protocol Buffers (`libprotobuf-c`, a mechanism for serializing structured data developed by Google, Inc.; see <https://protobuf.dev>).

To enable *dnstap* at compile time, the `fstrm` and `protobuf-c` libraries must be available, and BIND must be configured with `--enable-dnstap`.

The *dnstap* option is a bracketed list of message types to be logged. These may be set differently for each view. Supported types are `client`, `auth`, `resolver`, `forwarder`, and `update`. Specifying type `all` causes all *dnstap* messages to be logged, regardless of type.

Each type may take an additional argument to indicate whether to log `query` messages or `response` messages; if not specified, both queries and responses are logged.

Example: To log all authoritative queries and responses, recursive client responses, and upstream queries sent by the resolver, use:

```
dnstap {
  auth;
  client response;
  resolver query;
};
```

### **Note**

In the default configuration, the `dnstap` output for recursive resolver traffic does not include the IP addresses used by server-side sockets. This is caused by the fact that unless the *query source address* is explicitly set, these sockets are bound to wildcard IP addresses and determining the specific IP address used by each of them requires issuing a system call (i.e. incurring a performance penalty).

Logged `dnstap` messages can be parsed using the `dnstap-read` utility (see *dnstap-read - print dnstap data in human-readable form* for details).

For more information on `dnstap`, see <http://dnstap.info>.

The `fstrm` library has a number of tunables that are exposed in `named.conf`, and can be modified if necessary to improve performance or prevent loss of data. These are:

#### **fstrm-set-buffer-hint**

**Grammar:** `fstrm-set-buffer-hint <integer>;`

**Blocks:** options

**Tags:** logging

Sets the number of accumulated bytes in the output buffer before forcing a buffer flush.

The threshold number of bytes to accumulate in the output buffer before forcing a buffer flush. The minimum is 1024, the maximum is 65536, and the default is 8192.

#### **fstrm-set-flush-timeout**

**Grammar:** `fstrm-set-flush-timeout <integer>;`

**Blocks:** options

**Tags:** logging

Sets the number of seconds that unflushed data remains in the output buffer.

The number of seconds to allow unflushed data to remain in the output buffer. The minimum is 1 second, the maximum is 600 seconds (10 minutes), and the default is 1 second.

#### **fstrm-set-output-notify-threshold**

**Grammar:** `fstrm-set-output-notify-threshold <integer>;`

**Blocks:** options

**Tags:** logging

Sets the number of outstanding queue entries allowed on an input queue before waking the I/O thread.

The number of outstanding queue entries to allow on an input queue before waking the I/O thread. The minimum is 1 and the default is 32.

**fstrm-set-output-queue-model**

**Grammar:** `fstrm-set-output-queue-model ( mpsc | spsc );`

**Blocks:** options

**Tags:** logging

Sets the queuing semantics to use for queue objects.

The queuing semantics to use for queue objects. The default is `mpsc` (multiple producer, single consumer); the other option is `spsc` (single producer, single consumer).

**fstrm-set-input-queue-size**

**Grammar:** `fstrm-set-input-queue-size <integer>;`

**Blocks:** options

**Tags:** logging

Sets the number of queue entries to allocate for each input queue.

The number of queue entries to allocate for each input queue. This value must be a power of 2. The minimum is 2, the maximum is 16384, and the default is 512.

**fstrm-set-output-queue-size**

**Grammar:** `fstrm-set-output-queue-size <integer>;`

**Blocks:** options

**Tags:** logging

Sets the number of queue entries allocated for each output queue.

The number of queue entries to allocate for each output queue. The minimum is 2, the maximum is system-dependent and based on `IOV_MAX`, and the default is 64.

**fstrm-set-reopen-interval**

**Grammar:** `fstrm-set-reopen-interval <duration>;`

**Blocks:** options

**Tags:** logging

Sets the number of seconds to wait between attempts to reopen a closed output stream.

The number of seconds to wait between attempts to reopen a closed output stream. The minimum is 1 second, the maximum is 600 seconds (10 minutes), and the default is 5 seconds. For convenience, TTL-style time-unit suffixes may be used to specify the value.

Note that all of the above minimum, maximum, and default values are set by the `libfstrm` library, and may be subject to change in future versions of the library. See the `libfstrm` documentation for more information.

**dnstap-output**

**Grammar:** `dnstap-output ( file | unix ) <quoted_string> [ size ( unlimited | <size> ) ] [ versions ( unlimited | <integer> ) ] [ suffix ( increment | timestamp ) ] ;`

**Blocks:** options

**Tags:** logging

Configures the path to which the *dnstap* frame stream is sent.

This configures the path to which the *dnstap* frame stream is sent if *dnstap* is enabled at compile time and active.

The first argument is either *file* or *unix*, indicating whether the destination is a file or a Unix domain socket. The second argument is the path of the file or socket. (Note: when using a socket, *dnstap* messages are only sent if another process such as *fstrm\_capture* (provided with *libfstrm*) is listening on the socket.)

If the first argument is *file*, then up to three additional options can be added: *size* indicates the size to which a *dnstap* log file can grow before being rolled to a new file; *versions* specifies the number of rolled log files to retain; and *suffix* indicates whether to retain rolled log files with an incrementing counter as the suffix (*increment*) or with the current timestamp (*timestamp*). These are similar to the *size*, *versions*, and *suffix* options in a *logging* channel. The default is to allow *dnstap* log files to grow to any size without rolling.

*dnstap-output* can only be set globally in *options*. Currently, it can only be set once while *named* is running; once set, it cannot be changed by *rndc reload* or *rndc reconfig*.

**dnstap-identity**

**Grammar:** `dnstap-identity ( <quoted_string> | none | hostname ) ;`

**Blocks:** options

**Tags:** logging

Specifies an identity string to send in *dnstap* messages.

This specifies an identity string to send in *dnstap* messages. If set to *hostname*, which is the default, the server's hostname is sent. If set to *none*, no identity string is sent.

**dnstap-version**

**Grammar:** `dnstap-version ( <quoted_string> | none ) ;`

**Blocks:** options

**Tags:** logging

Specifies a *version* string to send in *dnstap* messages.

This specifies a *version* string to send in *dnstap* messages. The default is the version number of the BIND release. If set to *none*, no version string is sent.

**geoup-directory**

**Grammar:** `geoup-directory ( <quoted_string> | none ) ;`

**Blocks:** options

**Tags:** server

Specifies the directory containing GeoIP database files.

When *named* is compiled using the MaxMind GeoIP2 geolocation API, this specifies the directory containing GeoIP database files. By default, the option is set based on the prefix used to build the `libmaxminddb` module; for example, if the library is installed in `/usr/local/lib`, then the default *geoip-directory* is `/usr/local/share/GeoIP`. See *acl* for details about *geoip* ACLs.

**key-directory**

**Grammar:** `key-directory <quoted_string>;`

**Blocks:** options, view, zone (primary, secondary)

**Tags:** dnssec

Indicates the directory where public and private DNSSEC key files are found.

This is the directory where the public and private DNSSEC key files should be found when performing a dynamic update of secure zones, if different than the current working directory. (Note that this option has no effect on the paths for files containing non-DNSSEC keys such as `bind.keys`, `rndc.key`, or `session.key`.)

**lmdb-mapsize**

**Grammar:** `lmdb-mapsize <sizeval>;`

**Blocks:** options, view

**Tags:** server

Sets a maximum size for the memory map of the new-zone database in LMDB database format.

When *named* is built with `liblmbd`, this option sets a maximum size for the memory map of the new-zone database (NZD) in LMDB database format. This database is used to store configuration information for zones added using *rndc addzone*. Note that this is not the NZD database file size, but the largest size that the database may grow to.

Because the database file is memory-mapped, its size is limited by the address space of the *named* process. The default of 32 megabytes was chosen to be usable with 32-bit *named* builds. The largest permitted value is 1 terabyte. Given typical zone configurations without elaborate ACLs, a 32 MB NZD file ought to be able to hold configurations of about 100,000 zones.

**managed-keys-directory**

**Grammar:** `managed-keys-directory <quoted_string>;`

**Blocks:** options

**Tags:** dnssec

Specifies the directory in which to store the files that track managed DNSSEC keys.

This specifies the directory in which to store the files that track managed DNSSEC keys (i.e., those configured using the *initial-key* or *initial-ds* keywords in a *trust-anchors* statement). By default, this is the working directory. The directory *must* be writable by the effective user ID of the *named* process.

If *named* is not configured to use views, managed keys for the server are tracked in a single file called `managed-keys.bind`. Otherwise, managed keys are tracked in separate files, one file per view; each file name is the view name (or, if it contains characters that are incompatible with use as a file name, the SHA256 hash of the view name), followed by the extension `.mkeys`.

(Note: in earlier releases, file names for views always used the SHA256 hash of the view name. To ensure compatibility after upgrading, if a file using the old name format is found to exist, it is used instead of the new format.)

**max-ixfr-ratio**

**Grammar:** `max-ixfr-ratio ( unlimited | <percentage> );`

**Blocks:** options, view, zone (mirror, primary, secondary)

**Tags:** transfer

Sets the maximum size for IXFR responses to zone transfer requests.

This sets the size threshold (expressed as a percentage of the size of the full zone) beyond which *named* chooses to use an AXFR response rather than IXFR when answering zone transfer requests. See *Incremental Zone Transfers (IXFR)*.

The minimum value is 1%. The keyword `unlimited` disables ratio checking and allows IXFRs of any size. The default is 100%.

**new-zones-directory**

**Grammar:** `new-zones-directory <quoted_string>;`

**Blocks:** options, view

**Tags:** zone

Specifies the directory where configuration parameters are stored for zones added by *rndc addzone*.

This specifies the directory in which to store the configuration parameters for zones added via *rndc addzone*. By default, this is the working directory. If set to a relative path, it is relative to the working directory. The directory *must* be writable by the effective user ID of the *named* process.

**qname-minimization**

**Grammar:** `qname-minimization ( strict | relaxed | disabled | off );`

**Blocks:** options, view

**Tags:** query

Controls QNAME minimization behavior in the BIND 9 resolver.

When this is set to `strict`, BIND follows the QNAME minimization algorithm to the letter, as specified in **RFC 7816**.

Setting this option to `relaxed` causes BIND to fall back to normal (non-minimized) query mode when it receives either NXDOMAIN or other unexpected responses (e.g., SERVFAIL, improper zone cut, REFUSED) to a minimized query.

In `relaxed` mode *named* makes NS queries for `<domain>` as it walks down the tree.

`disabled` disables QNAME minimization completely. `off` is a synonym for `disabled`.

The current default is `relaxed`, but it may be changed to `strict` in a future release.

**tkey-gssapi-keytab**

**Grammar:** `tkey-gssapi-keytab <quoted_string>;`

**Blocks:** options

**Tags:** security

Sets the KRB5 keytab file to use for GSS-TSIG updates.

This is the KRB5 keytab file to use for GSS-TSIG updates. If this option is set and `tkey-gssapi-credential` is not set, updates are allowed with any key matching a principal in the specified keytab.

**tkey-gssapi-credential**

 **Warning**

This option is deprecated and will be removed in a future version of BIND.

**Grammar:** `tkey-gssapi-credential <quoted_string>; // deprecated`

**Blocks:** options

**Tags:** security

Sets the security credential for authentication keys requested by the GSS-TSIG protocol.

This is the security credential with which the server should authenticate keys requested by the GSS-TSIG protocol. Currently only Kerberos 5 authentication is available; the credential is a Kerberos principal which the server can acquire through the default system key file, normally `/etc/krb5.keytab`. The location of the keytab file can be overridden using the `tkey-gssapi-keytab` option. Normally this principal is of the form `DNS/server.domain`. To use GSS-TSIG, `tkey-domain` must also be set if a specific keytab is not set with `tkey-gssapi-keytab`.

**tkey-domain**

 **Warning**

This option is deprecated and will be removed in a future version of BIND.

**Grammar:** `tkey-domain <quoted_string>; // deprecated`

**Blocks:** options

**Tags:** security

Sets the domain appended to the names of all shared keys generated with `TKEY`.

This domain is appended to the names of all shared keys generated with `TKEY`. When a client requests a `TKEY` exchange, it may or may not specify the desired name for the key. If present, the name of the shared key is `client-specified part + tkey-domain`. Otherwise, the name of the shared key is `random hex digits + tkey-domain`. In most cases, the `domainname` should be the server's domain name, or an otherwise nonexistent subdomain like `_tkey.domainname`. If using GSS-TSIG, this variable must be defined, unless a specific keytab is specified using `tkey-gssapi-keytab`.

**tkey-dhkey**

**Warning**

This option is deprecated and will be removed in a future version of BIND.

**Grammar:** `tkey-dhkey <quoted_string> <integer>; // deprecated`

**Blocks:** options

**Tags:** deprecated

Sets the Diffie-Hellman key used by the server to generate shared keys.

This is the Diffie-Hellman key used by the server to generate shared keys with clients using the Diffie-Hellman mode of `TKEY`. The server must be able to load the public and private keys from files in the working directory. In most cases, the `key_name` should be the server's host name.

This option is deprecated, and will be rendered non-operational in a future release.

**dump-file**

**Grammar:** `dump-file <quoted_string>;`

**Blocks:** options

**Tags:** logging

Indicates the pathname of the file where the server dumps the database after `rndc dumpdb`.

This is the pathname of the file the server dumps the database to, when instructed to do so with `rndc dumpdb`. If not specified, the default is `named_dump.db`.

**memstatistics-file**

**Grammar:** `memstatistics-file <quoted_string>;`

**Blocks:** options

**Tags:** logging

Sets the pathname of the file where the server writes memory usage statistics on exit.

This is the pathname of the file the server writes memory usage statistics to on exit. If not specified, the default is `named.memstats`.

**lock-file**

**Grammar:** `lock-file ( <quoted_string> | none );`

**Blocks:** options

**Tags:** server

Sets the pathname of the file on which `named` attempts to acquire a file lock when starting for the first time.

This is the pathname of a file on which `named` attempts to acquire a file lock when starting for the first time; if unsuccessful, the server terminates, under the assumption that another server is already running. If not specified, the default is `none`.

Specifying `lock-file none` disables the use of a lock file. `lock-file` is ignored if `named` was run using the `-X` option, which overrides it. Changes to `lock-file` are ignored if `named` is being reloaded or reconfigured; it is only effective when the server is first started.

**pid-file**

**Grammar:** `pid-file ( <quoted_string> | none );`

**Blocks:** options

**Tags:** server

Specifies the pathname of the file where the server writes its process ID.

This is the pathname of the file the server writes its process ID in. If not specified, the default is `/usr/local/var/run/named.pid`. The PID file is used by programs that send signals to the running name server. Specifying `pid-file none` disables the use of a PID file; no file is written and any existing one is removed. Note that `none` is a keyword, not a filename, and therefore is not enclosed in double quotes.

**recursing-file**

**Grammar:** `recursing-file <quoted_string>;`

**Blocks:** options

**Tags:** server

Specifies the pathname of the file where the server dumps queries that are currently recursing via `rndc recursing`.

This is the pathname of the file where the server dumps the queries that are currently recursing, when instructed to do so with `rndc recursing`. If not specified, the default is `named.recursing`.

**statistics-file**

**Grammar:** `statistics-file <quoted_string>;`

**Blocks:** options

**Tags:** logging, server

Specifies the pathname of the file where the server appends statistics, when using `rndc stats`.

This is the pathname of the file the server appends statistics to, when instructed to do so using `rndc stats`. If not specified, the default is `named.stats` in the server's current directory. The format of the file is described in *The Statistics File*.

**bindkeys-file**

**Grammar:** `bindkeys-file <quoted_string>;`

**Blocks:** options

**Tags:** dnssec

Specifies the pathname of a file to override the built-in trusted keys provided by `named`.

This is the pathname of a file to override the built-in trusted keys provided by `named`. See the discussion of `dnssec-validation` for details. If not specified, the default is `/usr/local/etc/bind.keys`.

**secroots-file**

**Grammar:** `secroots-file <quoted_string>;`

**Blocks:** options

**Tags:** dnssec

Specifies the pathname of the file where the server dumps security roots, when using `rndc secroots`.

This is the pathname of the file the server dumps security roots to, when instructed to do so with `rndc secroots`. If not specified, the default is `named.secroots`.

**session-keyfile**

**Grammar:** `session-keyfile ( <quoted_string> | none );`

**Blocks:** options

**Tags:** security

Specifies the pathname of the file where a TSIG session key is written, when generated by `named` for use by `nsupdate -l`.

This is the pathname of the file into which to write a TSIG session key generated by `named` for use by `nsupdate -l`. If not specified, the default is `/usr/local/var/run/session.key`. (See *Dynamic Update Policies*, and in particular the discussion of the `update-policy` statement's `local` option, for more information about this feature.)

**session-keyname**

**Grammar:** `session-keyname <string>;`

**Blocks:** options

**Tags:** security

Specifies the key name for the TSIG session key.

This is the key name to use for the TSIG session key. If not specified, the default is `local-ddns`.

**session-keyalg**

**Grammar:** `session-keyalg <string>;`

**Blocks:** options

**Tags:** security

Specifies the algorithm to use for the TSIG session key.

This is the algorithm to use for the TSIG session key. Valid values are `hmac-sha1`, `hmac-sha224`, `hmac-sha256`, `hmac-sha384`, `hmac-sha512`, and `hmac-md5`. If not specified, the default is `hmac-sha256`.

**port**

**Grammar:** `port <integer>;`

**Blocks:** options

**Tags:** server, query

Specifies the UDP/TCP port number the server uses to receive and send DNS protocol traffic.

This is the UDP/TCP port number the server uses to receive and send DNS protocol traffic. The default is 53. This option is mainly intended for server testing; a server using a port other than 53 is not able to communicate with the global DNS.

**tls-port**

**Grammar:** `tls-port <integer>;`

**Blocks:** options

**Tags:** server, query

Specifies the TCP port number the server uses to receive and send DNS-over-TLS protocol traffic.

This is the TCP port number the server uses to receive and send DNS-over-TLS protocol traffic. The default is 853.

**https-port**

**Grammar:** `https-port <integer>;`

**Blocks:** options

**Tags:** server, query

Specifies the TCP port number the server uses to receive and send DNS-over-HTTPS protocol traffic.

This is the TCP port number the server uses to receive and send DNS-over-HTTPS protocol traffic. The default is 443.

**http-port**

**Grammar:** `http-port <integer>;`

**Blocks:** options

**Tags:** server, query

Specifies the TCP port number the server uses to receive and send unencrypted DNS traffic via HTTP.

This is the TCP port number the server uses to receive and send unencrypted DNS traffic via HTTP (a configuration that may be useful when encryption is handled by third-party software or by a reverse proxy).

**http-listener-clients**

**Grammar:** `http-listener-clients <integer>;`

**Blocks:** options

**Tags:** server

Limits the number of active concurrent connections on a per-listener basis.

This sets a hard limit on the number of active concurrent connections on a per-listener basis. The default value is 300; setting it to 0 removes the quota.

**http-streams-per-connection**

**Grammar:** `http-streams-per-connection <integer>;`

**Blocks:** options

**Tags:** server

Limits the number of active concurrent HTTP/2 streams on a per-connection basis.

This sets a hard limit on the number of active concurrent HTTP/2 streams on a per-connection basis. The default value is 100; setting it to 0 removes the limit. Once the limit is exceeded, the server finishes the HTTP session.

**dscp**

**Grammar:** `dscp <integer>; // obsolete`

**Blocks:** options

**Tags:** server, query

Sets the Differentiated Services Code Point (DSCP) value (obsolete).

This option used to set the global Differentiated Services Code Point (DSCP) value to classify outgoing DNS traffic. It is now obsolete and has no effect.

**preferred-glue**

**Grammar:** `preferred-glue <string>;`

**Blocks:** options, view

**Tags:** query

Controls the order of glue records in an A or AAAA response.

If specified, the listed type (A or AAAA) is emitted before other glue in the additional section of a query response. The default is to prefer A records when responding to queries that arrived via IPv4 and AAAA when responding to queries that arrived via IPv6.

**root-delegation-only**

 **Warning**

This option is deprecated and will be removed in a future version of BIND.

**Grammar:** `root-delegation-only [ exclude { <string>; ... } ]; // deprecated`

**Blocks:** options, view

**Tags:** deprecated

Turns on enforcement of delegation-only in top-level domains (TLDs) and root zones with an optional exclude list.

This turns on enforcement of delegation-only in top-level domains (TLDs) and root zones with an optional exclude list.

DS queries are expected to be made to and be answered by delegation-only zones. Such queries and responses are treated as an exception to delegation-only processing and are not converted to NXDOMAIN responses, provided a CNAME is not discovered at the query name.

If a delegation-only zone server also serves a child zone, it is not always possible to determine whether an answer comes from the delegation-only zone or the child zone. SOA NS and DNSKEY records are apex-only records and a matching response that contains these records or DS is treated as coming from a child zone. RRSIG records are also examined to see whether they are signed by a child zone, and the authority section is examined to see if there is evidence that the answer is from the child zone. Answers that are determined to be from a child zone are not converted to NXDOMAIN responses. Despite all these checks, there is still a possibility of false negatives when a child zone is being served.

Similarly, false positives can arise from empty nodes (no records at the name) in the delegation-only zone when the query type is not ANY.

Note that some TLDs are not delegation-only; e.g., "DE", "LV", "US", and "MUSEUM". This list is not exhaustive.

```
options {
    root-delegation-only exclude { "de"; "lv"; "us"; "museum"; };
};
```

This option is deprecated, and will be rendered non-operational in a future release.

**disable-algorithms**

**Grammar:** `disable-algorithms <string> { <string>; ... };` // may occur multiple times

**Blocks:** options, view

**Tags:** dnssec

Disables DNSSEC algorithms from a specified zone.

This disables the specified DNSSEC algorithms at and below the specified name. Multiple *disable-algorithms* statements are allowed. Only the best-match *disable-algorithms* clause is used to determine the algorithms.

If all supported algorithms are disabled, the zones covered by the *disable-algorithms* setting are treated as insecure.

Configured trust anchors in *trust-anchors* (or *managed-keys* or *trusted-keys*) that match a disabled algorithm are ignored and treated as if they were not configured.

**disable-ds-digests**

**Grammar:** `disable-ds-digests <string> { <string>; ... };` // may occur multiple times

**Blocks:** options, view

**Tags:** dnssec, zone

Disables DS digest types from a specified zone.

This disables the specified DS digest types at and below the specified name. Multiple *disable-ds-digests* statements are allowed. Only the best-match *disable-ds-digests* clause is used to determine the digest types.

If all supported digest types are disabled, the zones covered by *disable-ds-digests* are treated as insecure.

**dnssec-must-be-secure**

**Warning**

This option is deprecated and will be removed in a future version of BIND.

**Grammar:** `dnssec-must-be-secure <string> <boolean>; // may occur multiple times, deprecated`

**Blocks:** options, view

**Tags:** deprecated

Defines hierarchies that must or may not be secure (signed and validated).

This option is deprecated and will be removed in a future release.

This specifies hierarchies which must be or may not be secure (signed and validated). If `yes`, then `named` only accepts answers if they are secure. If `no`, then normal DNSSEC validation applies, allowing insecure answers to be accepted. The specified domain must be defined as a trust anchor, for instance in a `trust-anchors` statement, or `dnssec-validation auto` must be active.

**dns64****Grammar:**

```
dns64 <netprefix> {
    break-dnssec <boolean>;
    clients { <address_match_element>; ... };
    exclude { <address_match_element>; ... };
    mapped { <address_match_element>; ... };
    recursive-only <boolean>;
    suffix <ipv6_address>;
}; // may occur multiple times
```

**Blocks:** options, view

**Tags:** query

Instructs `named` to return mapped IPv4 addresses to AAAA queries when there are no AAAA records.

This directive instructs `named` to return mapped IPv4 addresses to AAAA queries when there are no AAAA records. It is intended to be used in conjunction with a NAT64. Each `dns64` defines one DNS64 prefix. Multiple DNS64 prefixes can be defined.

Compatible IPv6 prefixes have lengths of 32, 40, 48, 56, 64, and 96, per [RFC 6052](#). Bits 64..71 inclusive must be zero, with the most significant bit of the prefix in position 0.

In addition, a reverse IP6.ARPA zone is created for the prefix to provide a mapping from the IP6.ARPA names to the corresponding IN-ADDR.ARPA names using synthesized CNAMEs.

**dns64-server**

**Grammar:** `dns64-server <string>;`

**Blocks:** options, view

**Tags:** server

Specifies the name of the server for `dns64` zones.

**dns64-contact**

**Grammar:** `dns64-contact <string>;`

**Blocks:** options, view

**Tags:** server

Specifies the name of the contact for *dns64* zones.

*dns64-server* and *dns64-contact* can be used to specify the name of the server and contact for the zones. These can be set at the view/options level but not on a per-prefix basis.

*dns64* will also cause IPV4ONLY.ARPA to be created if not explicitly disabled using *ipv4only-enable*.

**clients**

**Grammar:** `clients { <address_match_element>; ... };`

**Blocks:** options.dns64, view.dns64

**Tags:** query

Specifies an access control list (ACL) of clients that are affected by a given *dns64* directive.

Each *dns64* supports an optional *clients* ACL that determines which clients are affected by this directive. If not defined, it defaults to *any*;

**mapped**

**Grammar:** `mapped { <address_match_element>; ... };`

**Blocks:** options.dns64, view.dns64

**Tags:** query

Specifies an access control list (ACL) of IPv4 addresses that are to be mapped to the corresponding A RRset in *dns64*.

Each *dns64* block supports an optional *mapped* ACL that selects which IPv4 addresses are to be mapped in the corresponding A RRset. If not defined, it defaults to *any*;

**exclude**

**Grammar:** `exclude { <address_match_element>; ... };`

**Blocks:** options.dns64, view.dns64

**Tags:** query

Allows a list of IPv6 addresses to be ignored if they appear in a domain name's AAAA records in *dns64*.

Normally, DNS64 does not apply to a domain name that owns one or more AAAA records; these records are simply returned. The optional *exclude* ACL allows specification of a list of IPv6 addresses that are ignored if they appear in a domain name's AAAA records; DNS64 is applied to any A records the domain name owns. If not defined, *exclude* defaults to `::ffff:0.0.0.0/96`.

**suffix**

**Grammar:** `suffix <ipv6_address>;`

**Blocks:** options.dns64, view.dns64

**Tags:** query

Defines trailing bits for mapped IPv4 address bits in *dns64*.

An optional *suffix* can also be defined to set the bits trailing the mapped IPv4 address bits. By default these bits are set to `::`. The bits matching the prefix and mapped IPv4 address must be zero.

#### **recursive-only**

**Grammar:** `recursive-only <boolean>;`

**Blocks:** `options.dns64, view.dns64`

**Tags:** query

Toggles whether *dns64* synthesis occurs only for recursive queries.

If *recursive-only* is set to `yes`, the DNS64 synthesis only happens for recursive queries. The default is `no`.

#### **break-dnssec**

**Grammar:** `break-dnssec <boolean>;`

**Blocks:** `options.dns64, view.dns64`

**Tags:** query

Enables *dns64* synthesis even if the validated result would cause a DNSSEC validation failure.

If *break-dnssec* is set to `yes`, the DNS64 synthesis happens even if the result, if validated, would cause a DNSSEC validation failure. If this option is set to `no` (the default), the DO is set on the incoming query, and there are RRSIGs on the applicable records, then synthesis does not happen.

```
acl rfc1918 { 10/8; 192.168/16; 172.16/12; };

dns64 64:FF9B::/96 {
    clients { any; };
    mapped { !rfc1918; any; };
    exclude { 64:FF9B::/96; ::ffff:0000:0000/96; };
    suffix ::;
};
```

#### **ipv4only-enable**

**Grammar:** `ipv4only-enable <boolean>;`

**Blocks:** `options, view`

**Tags:** query

Enables automatic IPv4 zones if a *dns64* block is configured.

This enables or disables automatic zones `ipv4only.arpa`, `170.0.0.192.in-addr.arpa`, and `171.0.0.192.in-addr.arpa`.

By default these zones are loaded if *dns64* is configured.

**ipv4only-server****Grammar:** `ipv4only-server <string>;`**Blocks:** options, view**Tags:** server, query

Specifies the name of the server for the IPV4ONLY.ARPA zone created by *dns64*.

**ipv4only-contact****Grammar:** `ipv4only-contact <string>;`**Blocks:** options, view**Tags:** server

Specifies the contact for the IPV4ONLY.ARPA zone created by *dns64*.

*ipv4only-server* and *ipv4only-contact* can be used to specify the name of the server and contact for the IPV4ONLY.ARPA zone created by *dns64*.

**dnssec-loadkeys-interval****Grammar:** `dnssec-loadkeys-interval <integer>;`**Blocks:** options, view, zone (primary, secondary)**Tags:** dnssec

Sets the frequency of automatic checks of the DNSSEC key repository.

When a zone is configured with `auto-dnssec maintain;`, its key repository must be checked periodically to see if any new keys have been added or any existing keys' timing metadata has been updated (see *dnssec-keygen: DNSSEC key generation tool* and *dnssec-settime: set the key timing metadata for a DNSSEC key*). The *dnssec-loadkeys-interval* option sets the frequency of automatic repository checks, in minutes. The default is 60 (1 hour), the minimum is 1 (1 minute), and the maximum is 1440 (24 hours); any higher value is silently reduced.

*dnssec-policy*

This specifies which key and signing policy (KASP) should be used for this zone. This is a string referring to a *dnssec-policy* block. The default is *none*.

**dnssec-update-mode****Grammar:** `dnssec-update-mode ( maintain | no-resign );`**Blocks:** options, view, zone (primary, secondary)**Tags:** dnssec

Controls the scheduled maintenance of DNSSEC signatures.

If this option is set to its default value of *maintain* in a zone of *type primary* which is DNSSEC-signed and configured to allow dynamic updates (see *Dynamic Update Policies*), and if *named* has access to the private signing key(s) for the zone, then *named* automatically signs all new or changed records and maintains signatures for the zone by regenerating RRSIG records whenever they approach their expiration date.

If the option is changed to *no-resign*, then *named* signs all new or changed records, but scheduled maintenance of signatures is disabled.

With either of these settings, *named* rejects updates to a DNSSEC-signed zone when the signing keys are inactive or unavailable to *named*. (A planned third option, *external*, will disable all automatic signing and allow DNSSEC data to be submitted into a zone via dynamic update; this is not yet implemented.)

#### **nta-lifetime**

**Grammar:** *nta-lifetime* <duration>;

**Blocks:** options, view

**Tags:** dnssec

Specifies the lifetime, in seconds, for negative trust anchors added via *rndc nta*.

This specifies the default lifetime, in seconds, for negative trust anchors added via *rndc nta*.

A negative trust anchor selectively disables DNSSEC validation for zones that are known to be failing because of misconfiguration, rather than an attack. When data to be validated is at or below an active NTA (and above any other configured trust anchors), *named* aborts the DNSSEC validation process and treats the data as insecure rather than bogus. This continues until the NTA's lifetime has elapsed. NTAs persist across *named* restarts.

For convenience, TTL-style time-unit suffixes can be used to specify the NTA lifetime in seconds, minutes, or hours. It also accepts ISO 8601 duration formats.

*nta-lifetime* defaults to one hour; it cannot exceed one week.

#### **nta-recheck**

**Grammar:** *nta-recheck* <duration>;

**Blocks:** options, view

**Tags:** dnssec

Specifies the time interval for checking whether negative trust anchors added via *rndc nta* are still necessary.

This specifies how often to check whether negative trust anchors added via *rndc nta* are still necessary.

A negative trust anchor is normally used when a domain has stopped validating due to operator error; it temporarily disables DNSSEC validation for that domain. In the interest of ensuring that DNSSEC validation is turned back on as soon as possible, *named* periodically sends a query to the domain, ignoring negative trust anchors, to find out whether it can now be validated. If so, the negative trust anchor is allowed to expire early.

Validity checks can be disabled for an individual NTA by using *rndc nta -f*, or for all NTAs by setting *nta-recheck* to zero.

For convenience, TTL-style time-unit suffixes can be used to specify the NTA recheck interval in seconds, minutes, or hours. It also accepts ISO 8601 duration formats.

The default is five minutes. It cannot be longer than *nta-lifetime*, which cannot be longer than a week.

#### **max-zone-ttl**

##### **tags**

deprecated

##### **short**

Specifies a maximum permissible time-to-live (TTL) value, in seconds.

This should now be configured as part of *dnssec-policy*. Use of this option in *options*, *view* and *zone* blocks has no effect on any zone for which a *dnssec-policy* has also been configured.

*max-zone-ttl* specifies a maximum permissible TTL value in seconds. For convenience, TTL-style time-unit suffixes may be used to specify the maximum value. When a zone file is loaded, any record encountered with a TTL higher than *max-zone-ttl* causes the zone to be rejected.

This is needed in DNSSEC-maintained zones because when rolling to a new DNSKEY, the old key needs to remain available until RRSIG records have expired from caches. The *max-zone-ttl* option guarantees that the largest TTL in the zone is no higher than the set value.

When used in *options*, *view* and *zone* blocks, setting *max-zone-ttl* to zero is equivalent to "unlimited".

#### **stale-answer-ttl**

**Grammar:** `stale-answer-ttl <duration>;`

**Blocks:** *options*, *view*

**Tags:** *query*

Specifies the time to live (TTL) to be returned on stale answers, in seconds.

This specifies the TTL to be returned on stale answers. The default is 30 seconds. The minimum allowed is 1 second; a value of 0 is updated silently to 1 second.

For stale answers to be returned, they must be enabled, either in the configuration file using *stale-answer-enable* or via *rndc serve-stale on*.

#### **serial-update-method**

**Grammar:** `serial-update-method ( date | increment | unixtime );`

**Blocks:** *options*, *view*, *zone* (primary)

**Tags:** *zone*

Specifies the update method to be used for the zone serial number in the SOA record.

Zones configured for dynamic DNS may use this option to set the update method to be used for the zone serial number in the SOA record.

With the default setting of `serial-update-method increment;`, the SOA serial number is incremented by one each time the zone is updated.

When set to `serial-update-method unixtime;`, the SOA serial number is set to the number of seconds since the Unix epoch, unless the serial number is already greater than or equal to that value, in which case it is simply incremented by one.

When set to `serial-update-method date;`, the new SOA serial number is the current date in the form "YYYYMMDD", followed by two zeroes, unless the existing serial number is already greater than or equal to that value, in which case it is incremented by one.

#### **zone-statistics**

**Grammar:** `zone-statistics ( full | terse | none | <boolean> );`

**Blocks:** *options*, *view*, *zone* (*mirror*, *primary*, *redirect*, *secondary*, *static-stub*, *stub*)

**Tags:** *zone*, *logging*

Controls the level of statistics gathered for all zones.

If *full*, the server collects statistical data on all zones, unless specifically turned off on a per-zone basis by specifying `zone-statistics terse` or `zone-statistics none` in the *zone* statement. The statistical data

includes, for example, DNSSEC signing operations and the number of authoritative answers per query type. The default is `terse`, providing minimal statistics on zones (including name and current serial number, but not query type counters).

These statistics may be accessed via the `statistics-channel` or using `rndc stats`, which dumps them to the file listed in the `statistics-file`. See also *The Statistics File*.

For backward compatibility with earlier versions of BIND 9, the `zone-statistics` option can also accept `yes` or `no`; `yes` has the same meaning as `full`. As of BIND 9.10, `no` has the same meaning as `none`; previously, it was the same as `terse`.

## Boolean Options

### `automatic-interface-scan`

**Grammar:** `automatic-interface-scan <boolean>;`

**Blocks:** options

**Tags:** server

Controls the automatic rescanning of network interfaces when addresses are added or removed.

If `yes` and supported by the operating system, this automatically rescans network interfaces when the interface addresses are added or removed. The default is `yes`. This configuration option does not affect the time-based `interface-interval` option; it is recommended to set the time-based `interface-interval` to 0 when the operator confirms that automatic interface scanning is supported by the operating system.

The `automatic-interface-scan` implementation uses routing sockets for the network interface discovery; therefore, the operating system must support the routing sockets for this feature to work.

### `allow-new-zones`

**Grammar:** `allow-new-zones <boolean>;`

**Blocks:** options, view

**Tags:** server, zone

Controls the ability to add zones at runtime via `rndc addzone`.

If `yes`, then zones can be added at runtime via `rndc addzone`. The default is `no`.

Newly added zones' configuration parameters are stored so that they can persist after the server is restarted. The configuration information is saved in a file called `viewname.nzf` (or, if `named` is compiled with `liblmdb`, in an LMDB database file called `viewname.nzd`). "viewname" is the name of the view, unless the view name contains characters that are incompatible with use as a file name, in which case a cryptographic hash of the view name is used instead.

Configurations for zones added at runtime are stored either in a new-zone file (NZF) or a new-zone database (NZD), depending on whether `named` was linked with `liblmdb` at compile time. See *rndc - name server control utility* for further details about `rndc addzone`.

### `auth-nxdomain`

**Grammar:** `auth-nxdomain <boolean>;`

**Blocks:** options, view

**Tags:** query

Controls whether BIND, acting as a resolver, provides authoritative NXDOMAIN (domain does not exist) answers.

If *yes*, then the *AA* bit is always set on NXDOMAIN responses, even if the server is not actually authoritative. The default is *no*.

**memstatistics**

**Grammar:** `memstatistics <boolean>;`

**Blocks:** options

**Tags:** server, logging

Controls whether memory statistics are written to the file specified by *memstatistics-file* at exit.

This writes memory statistics to the file specified by *memstatistics-file* at exit. The default is *no* unless *-m record* is specified on the command line, in which case it is *yes*.

**dialup**

 **Warning**

This option is deprecated and will be removed in a future version of BIND.

**Grammar:** `dialup ( notify | notify-passive | passive | refresh | <boolean> ); // deprecated`

**Blocks:** options, view, zone (primary, secondary, stub)

**Tags:** deprecated

Concentrates zone maintenance so that all transfers take place once every *heartbeat-interval*, ideally during a single call.

This option is deprecated and will be removed in a future release.

If *yes*, then the server treats all zones as if they are doing zone transfers across a dial-on-demand dialup link, which can be brought up by traffic originating from this server. Although this setting has different effects according to zone type, it concentrates the zone maintenance so that everything happens quickly, once every *heartbeat-interval*, ideally during a single call. It also suppresses some normal zone maintenance traffic. The default is *no*.

If specified in the *view* and *zone* statements, the *dialup* option overrides the global *dialup* option.

If the zone is a primary zone, the server sends out a NOTIFY request to all the secondaries (default). This should trigger the zone serial number check in the secondary (providing it supports NOTIFY), allowing the secondary to verify the zone while the connection is active. The set of servers to which NOTIFY is sent can be controlled by *notify* and *also-notify*.

If the zone is a secondary or stub zone, the server suppresses the regular "zone up to date" (refresh) queries and only performs them when the *heartbeat-interval* expires, in addition to sending NOTIFY requests.

Finer control can be achieved by using *notify*, which only sends NOTIFY messages; *notify-passive*, which sends NOTIFY messages and suppresses the normal refresh queries; *refresh*, which suppresses normal refresh processing and sends refresh queries when the *heartbeat-interval* expires; and *passive*, which disables normal refresh processing.

dialup mode	normal refresh	heart-beat refresh	heart-beat notify
no (default)	yes	no	no
yes	no	yes	yes
notify	yes	no	yes
refresh	no	yes	no
passive	no	no	no
notify-passive	no	no	yes

Note that normal NOTIFY processing is not affected by *dialup*.

**flush-zones-on-shutdown**

**Grammar:** `flush-zones-on-shutdown <boolean>;`

**Blocks:** options

**Tags:** zone

Controls whether pending zone writes are flushed when the name server exits.

When the name server exits upon receiving SIGTERM, flush or do not flush any pending zone writes. The default is `flush-zones-on-shutdown no`.

**root-key-sentinel**

**Grammar:** `root-key-sentinel <boolean>;`

**Blocks:** options, view

**Tags:** server

Controls whether BIND 9 responds to root key sentinel probes.

If *yes*, the server responds to root key sentinel probes as described in [RFC 8509](#). The default is *yes*.

**reuseport**

**Grammar:** `reuseport <boolean>;`

**Blocks:** options

**Tags:** server

Enables kernel load-balancing of sockets.

This option enables kernel load-balancing of sockets on systems which support it, including Linux (SO\_REUSEPORT) and FreeBSD (SO\_REUSEPORT\_LB). This instructs the kernel to distribute incoming socket connections among the networking threads based on a hashing scheme. For more information, see the receive network flow classification options (*rx-flow-hash*) section in the `ethtool` manual page. The default is *yes*.

Enabling *reuseport* significantly increases general throughput when incoming traffic is distributed uniformly onto the threads by the operating system. However, in cases where a worker thread is busy with a long-lasting operation, such as processing a Response Policy Zone (RPZ) or Catalog Zone update or an unusually large zone transfer, incoming traffic that hashes onto that thread may be delayed. On servers where these events occur frequently, it may be preferable to disable socket load-balancing so that other threads can pick up the traffic that would have been sent to the busy thread.

Note: this option can only be set when `named` first starts. Changes will not take effect during reconfiguration; the server must be restarted.

**message-compression**

**Grammar:** `message-compression <boolean>;`

**Blocks:** options, view

**Tags:** query

Controls whether DNS name compression is used in responses to regular queries.

If *yes*, DNS name compression is used in responses to regular queries (not including AXFR or IXFR, which always use compression). Setting this option to *no* reduces CPU usage on servers and may improve throughput. However, it increases response size, which may cause more queries to be processed using TCP; a server with compression disabled is out of compliance with **RFC 1123** Section 6.1.3.2. The default is *yes*.

**minimal-responses**

**Grammar:** `minimal-responses ( no-auth | no-auth-recursive | <boolean> );`

**Blocks:** options, view

**Tags:** query

Controls whether the server only adds records to the authority and additional data sections when they are required (e.g. delegations, negative responses). This improves server performance.

This option controls the addition of records to the authority and additional sections of responses. Such records may be included in responses to be helpful to clients; for example, MX records may have associated address records included in the additional section, obviating the need for a separate address lookup. However, adding these records to responses is not mandatory and requires additional database lookups, causing extra latency when marshalling responses.

Responses to DNSKEY, DS, CDNSKEY, and CDS requests will never have optional additional records added. Responses to NS requests will always have additional section processing.

*minimal-responses* takes one of four values:

- *no*: the server is as complete as possible when generating responses.
- *yes*: the server only adds records to the authority and additional sections when such records are required by the DNS protocol (for example, when returning delegations or negative responses). This provides the best server performance but may result in more client queries.
- *no-auth*: the server omits records from the authority section except when they are required, but it may still add records to the additional section.
- *no-auth-recursive*: the same as *no-auth* when recursion is requested in the query (RD=1), or the same as *no* if recursion is not requested.

*no-auth* and *no-auth-recursive* are useful when answering stub clients, which usually ignore the authority section. *no-auth-recursive* is meant for use in mixed-mode servers that handle both authoritative and recursive queries.

The default is *no-auth-recursive*.

**glue-cache**

**Warning**

This option is deprecated and will be removed in a future version of BIND.

**Grammar:** `glue-cache <boolean>; // deprecated`

**Blocks:** options, view

**Tags:** deprecated

Deprecated.

When set to `yes`, a cache is used to improve query performance when adding address-type (A and AAAA) glue records to the additional section of DNS response messages that delegate to a child zone.

The glue cache uses memory proportional to the number of delegations in the zone. The default setting is `yes`, which improves performance at the cost of increased memory usage for the zone. To avoid this, set it to `no`.

**Note**

This option is deprecated and its use is discouraged. The glue cache will be permanently *enabled* in a future release.

**minimal-any**

**Grammar:** `minimal-any <boolean>;`

**Blocks:** options, view

**Tags:** query

Controls whether the server replies with only one of the RRsets for a query name, when generating a positive response to a query of type ANY over UDP.

If set to `yes`, the server replies with only one of the RRsets for the query name, and its covering RRSIGs if any, when generating a positive response to a query of type ANY over UDP, instead of replying with all known RRsets for the name. Similarly, a query for type RRSIG is answered with the RRSIG records covering only one type. This can reduce the impact of some kinds of attack traffic, without harming legitimate clients. (Note, however, that the RRset returned is the first one found in the database; it is not necessarily the smallest available RRset.) Additionally, *minimal-responses* is turned on for these queries, so no unnecessary records are added to the authority or additional sections. The default is `no`.

**notify**

**Grammar:** `notify ( explicit | master-only | primary-only | <boolean> );`

**Blocks:** options, view, zone (mirror, primary, secondary)

**Tags:** transfer

Controls whether NOTIFY messages are sent on zone changes.

If set to `yes` (the default), DNS NOTIFY messages are sent when a zone the server is authoritative for changes; see *using notify*. The messages are sent to the servers listed in the zone's NS records (except the primary server identified in the SOA MNAME field), and to any servers listed in the *also-notify* option.

If set to `primary-only` (or the older keyword `master-only`), notifies are only sent for primary zones. If set to `explicit`, notifies are sent only to servers explicitly listed using `also-notify`. If set to `no`, no notifies are sent.

The `notify` option may also be specified in the `zone` statement, in which case it overrides the `options notify` statement. It would only be necessary to turn off this option if it caused secondary zones to crash.

**notify-to-soa**

**Grammar:** `notify-to-soa <boolean>;`

**Blocks:** `options`, `view`, `zone` (`primary`, `secondary`)

**Tags:** `transfer`

Controls whether the name servers in the NS RRset are checked against the SOA MNAME.

If `yes`, do not check the name servers in the NS RRset against the SOA MNAME. Normally a NOTIFY message is not sent to the SOA MNAME (SOA ORIGIN), as it is supposed to contain the name of the ultimate primary server. Sometimes, however, a secondary server is listed as the SOA MNAME in hidden primary configurations; in that case, the ultimate primary should be set to still send NOTIFY messages to all the name servers listed in the NS RRset.

**recursion**

**Grammar:** `recursion <boolean>;`

**Blocks:** `options`, `view`

**Tags:** `query`

Defines whether recursion and caching are allowed.

If `yes`, and a DNS query requests recursion, then the server attempts to do all the work required to answer the query. If recursion is off and the server does not already know the answer, it returns a referral response. The default is `yes`. Note that setting `recursion no` does not prevent clients from getting data from the server's cache; it only prevents new data from being cached as an effect of client queries. Caching may still occur as an effect of the server's internal operation, such as NOTIFY address lookups.

**request-nsid**

**Grammar:** `request-nsid <boolean>;`

**Blocks:** `options`, `server`, `view`, `view.server`

**Tags:** `query`

Controls whether an empty EDNS(0) NSID (Name Server Identifier) option is sent with all queries to authoritative name servers during iterative resolution.

If `yes`, then an empty EDNS(0) NSID (Name Server Identifier) option is sent with all queries to authoritative name servers during iterative resolution. If the authoritative server returns an NSID option in its response, then its contents are logged in the `nsid` category at level `info`. The default is `no`.

**require-server-cookie**

**Grammar:** `require-server-cookie <boolean>;`

**Blocks:** `options`, `view`

**Tags:** `query`

Controls whether a valid server cookie is required before sending a full response to a UDP request.

If *yes*, require a valid server cookie before sending a full response to a UDP request from a cookie-aware client. BADCOOKIE is sent if there is a bad or nonexistent server cookie.

The default is *no*.

Users wishing to test that DNS COOKIE clients correctly handle BADCOOKIE, or who are getting a lot of forged DNS requests with DNS COOKIES present, should set this to *yes*. Setting this to *yes* results in a reduced amplification effect in a reflection attack, as the BADCOOKIE response is smaller than a full response, while also requiring a legitimate client to follow up with a second query with the new, valid, cookie.

#### **answer-cookie**

**Grammar:** `answer-cookie <boolean>;`

**Blocks:** options

**Tags:** query

Controls whether COOKIE EDNS replies are sent in response to client queries.

When set to the default value of *yes*, COOKIE EDNS options are sent when applicable in replies to client queries. If set to *no*, COOKIE EDNS options are not sent in replies. This can only be set at the global options level, not per-view.

`answer-cookie no` is intended as a temporary measure, for use when *named* shares an IP address with other servers that do not yet support DNS COOKIE. A mismatch between servers on the same address is not expected to cause operational problems, but the option to disable COOKIE responses so that all servers have the same behavior is provided out of an abundance of caution. DNS COOKIE is an important security mechanism, and should not be disabled unless absolutely necessary.

#### **send-cookie**

**Grammar:** `send-cookie <boolean>;`

**Blocks:** options, server, view, view.server

**Tags:** query

Controls whether a COOKIE EDNS option is sent along with a query.

If *yes*, then a COOKIE EDNS option is sent along with the query. If the resolver has previously communicated with the server, the COOKIE returned in the previous transaction is sent. This is used by the server to determine whether the resolver has talked to it before. A resolver sending the correct COOKIE is assumed not to be an off-path attacker sending a spoofed-source query; the query is therefore unlikely to be part of a reflection/amplification attack, so resolvers sending a correct COOKIE option are not subject to response rate limiting (RRL). Resolvers which do not send a correct COOKIE option may be limited to receiving smaller responses via the `nocookie-udp-size` option.

The *named* server may determine that COOKIE is not supported by the remote server and not add a COOKIE EDNS option to requests.

The default is *yes*.

#### **stale-answer-enable**

**Grammar:** `stale-answer-enable <boolean>;`

**Blocks:** options, view

**Tags:** server, query

Enables the returning of "stale" cached answers when the name servers for a zone are not answering.

If *yes*, enable the returning of "stale" cached answers when the name servers for a zone are not answering and the *stale-cache-enable* option is also enabled. The default is not to return stale answers.

Stale answers can also be enabled or disabled at runtime via *rndc serve-stale on* or *rndc serve-stale off*; these override the configured setting. *rndc serve-stale reset* restores the setting to the one specified in *named.conf*. Note that if stale answers have been disabled by *rndc*, they cannot be re-enabled by reloading or reconfiguring *named*; they must be re-enabled with *rndc serve-stale on*, or the server must be restarted.

Information about stale answers is logged under the *serve-stale* log category.

#### **stale-answer-client-timeout**

**Grammar:** *stale-answer-client-timeout* ( *disabled* | *off* | *<integer>* );

**Blocks:** options, view

**Tags:** server, query

Defines the amount of time (in milliseconds) that *named* waits before attempting to answer a query with a stale RRset from cache.

This option defines the amount of time (in milliseconds) that *named* waits before attempting to answer the query with a stale RRset from cache. If a stale answer is found, *named* continues the ongoing fetches, attempting to refresh the RRset in cache until the *resolver-query-timeout* interval is reached.

This option is off by default, which is equivalent to setting it to *off* or *disabled*. It also has no effect if *stale-answer-enable* is disabled.

The maximum value for this option is *resolver-query-timeout* minus one second. The minimum value, 0, causes a cached (stale) RRset to be immediately returned if it is available while still attempting to refresh the data in cache. **RFC 8767** recommends a value of 1800 (milliseconds).

#### **stale-cache-enable**

**Grammar:** *stale-cache-enable* *<boolean>*;

**Blocks:** options, view

**Tags:** server, query

Enables the retention of "stale" cached answers.

If *yes*, enable the retaining of "stale" cached answers. Default *no*.

#### **stale-refresh-time**

**Grammar:** *stale-refresh-time* *<duration>*;

**Blocks:** options, view

**Tags:** server, query

Sets the time window for the return of "stale" cached answers before the next attempt to contact, if the name servers for a given zone are not responding.

If the name servers for a given zone are not answering, this sets the time window for which *named* will promptly return "stale" cached answers for that RRset being requested before a new attempt in contacting the servers is

made. For convenience, TTL-style time-unit suffixes may be used to specify the value. It also accepts ISO 8601 duration formats.

The default *stale-refresh-time* is 30 seconds, as [RFC 8767](#) recommends that attempts to refresh to be done no more frequently than every 30 seconds. A value of zero disables the feature, meaning that normal resolution will take place first, if that fails only then *named* will return "stale" cached answers.

#### **nocookie-udp-size**

**Grammar:** `nocookie-udp-size <integer>;`

**Blocks:** options, view

**Tags:** query

Sets the maximum size of UDP responses that are sent to queries without a valid server COOKIE.

This sets the maximum size of UDP responses that are sent to queries without a valid server COOKIE. A value below 128 is silently raised to 128. The default value is 4096, but the *max-udp-size* option may further limit the response size as the default for *max-udp-size* is 1232.

#### **cookie-algorithm**

**Grammar:** `cookie-algorithm ( aes | siphash24 );`

**Blocks:** options

**Tags:** server

Sets the algorithm to be used when generating a server cookie.

This sets the algorithm to be used when generating the server cookie; the options are "aes" or "siphash24". The default is "siphash24". The "aes" option remains for legacy purposes.

#### **cookie-secret**

**Grammar:** `cookie-secret <string>; // may occur multiple times`

**Blocks:** options

**Tags:** server

Specifies a shared secret used for generating and verifying EDNS COOKIE options within an anycast cluster.

If set, this is a shared secret used for generating and verifying EDNS COOKIE options within an anycast cluster. If not set, the system generates a random secret at startup. The shared secret is encoded as a hex string and needs to be 128 bits for either "siphash24" or "aes".

If there are multiple secrets specified, the first one listed in *named.conf* is used to generate new server cookies. The others are only used to verify returned cookies.

#### **response-padding**

**Grammar:** `response-padding { <address_match_element>; ... } block-size <integer>;`

**Blocks:** options, view

**Tags:** query

Adds an EDNS Padding option to encrypted messages, to reduce the chance of guessing the contents based on size.

The EDNS Padding option is intended to improve confidentiality when DNS queries are sent over an encrypted channel, by reducing the variability in packet sizes. If a query:

1. contains an EDNS Padding option,
2. includes a valid server cookie or uses TCP,
3. is not signed using TSIG or SIG(0), and
4. is from a client whose address matches the specified ACL,

then the response is padded with an EDNS Padding option to a multiple of `block-size` bytes. If these conditions are not met, the response is not padded.

If `block-size` is 0 or the ACL is `none`, this feature is disabled and no padding occurs; this is the default. If `block-size` is greater than 512, a warning is logged and the value is truncated to 512. Block sizes are ordinarily expected to be powers of two (for instance, 128), but this is not mandatory.

**trust-anchor-telemetry**

**Grammar:** `trust-anchor-telemetry <boolean>;`

**Blocks:** options, view

**Tags:** dnssec

Instructs *named* to send specially formed queries once per day to domains for which trust anchors have been configured.

This causes *named* to send specially formed queries once per day to domains for which trust anchors have been configured via, e.g., `trust-anchors` or `dnssec-validation auto`.

The query name used for these queries has the form `_ta-xxxx(-xxxx)(...)<domain>`, where each "xxxx" is a group of four hexadecimal digits representing the key ID of a trusted DNSSEC key. The key IDs for each domain are sorted smallest to largest prior to encoding. The query type is NULL.

By monitoring these queries, zone operators are able to see which resolvers have been updated to trust a new key; this may help them decide when it is safe to remove an old one.

The default is `yes`.

**provide-ixfr**

**Grammar:** `provide-ixfr <boolean>;`

**Blocks:** options, server, view, view.server

**Tags:** transfer

Controls whether a primary responds to an incremental zone request (IXFR) or only responds with a full zone transfer (AXFR).

The `provide-ixfr` clause determines whether the local server, acting as primary, responds with an incremental zone transfer when the given remote server, a secondary, requests it. If set to `yes`, incremental transfer is provided whenever possible. If set to `no`, all transfers to the remote server are non-incremental.

**request-ixfr**

**Grammar:** `request-ixfr <boolean>;`

**Blocks:** options, server, view, zone (mirror, secondary), view.server

**Tags:** transfer

Controls whether a secondary requests an incremental zone transfer (IXFR) or a full zone transfer (AXFR).

The `request-ixfr` statement determines whether the local server, acting as a secondary, requests incremental zone transfers from the given remote server, a primary.

IXFR requests to servers that do not support IXFR automatically fall back to AXFR. Therefore, there is no need to manually list which servers support IXFR and which ones do not; the global default of `yes` should always work. The purpose of the `provide-ixfr` and `request-ixfr` statements is to make it possible to disable the use of IXFR even when both primary and secondary claim to support it: for example, if one of the servers is buggy and crashes or corrupts data when IXFR is used.

It may also be set in the zone block; if set there, it overrides the global or view setting for that zone. It may also be set in the `server` block.

#### **request-expire**

**Grammar:** `request-expire <boolean>;`

**Blocks:** options, server, view, zone (mirror, secondary), view.server

**Tags:** transfer, query

Specifies whether the local server requests the EDNS EXPIRE value, when acting as a secondary.

The `request-expire` statement determines whether the local server, when acting as a secondary, requests the EDNS EXPIRE value. The EDNS EXPIRE value indicates the remaining time before the zone data expires and needs to be refreshed. This is used when a secondary server transfers a zone from another secondary server; when transferring from the primary, the expiration timer is set from the EXPIRE field of the SOA record instead. The default is `yes`.

#### **match-mapped-addresses**

**Grammar:** `match-mapped-addresses <boolean>;`

**Blocks:** options

**Tags:** server

Allows IPv4-mapped IPv6 addresses to match address-match list entries for corresponding IPv4 addresses.

If `yes`, then an IPv4-mapped IPv6 address matches any address-match list entries that match the corresponding IPv4 address.

This option was introduced to work around a kernel quirk in some operating systems that causes IPv4 TCP connections, such as zone transfers, to be accepted on an IPv6 socket using mapped addresses. This caused address-match lists designed for IPv4 to fail to match. However, `named` now solves this problem internally. The use of this option is discouraged.

#### **ixfr-from-differences**

**Grammar zone (mirror, primary, secondary):** `ixfr-from-differences <boolean>;`

**Grammar options, view:** `ixfr-from-differences ( primary | master | secondary | slave | <boolean> );`

**Blocks:** options, view, zone (mirror, primary, secondary)

**Tags:** transfer

Controls how IXFR transfers are calculated.

When *yes* and the server loads a new version of a primary zone from its zone file or receives a new version of a secondary file via zone transfer, it compares the new version to the previous one and calculates a set of differences. The differences are then logged in the zone's journal file so that the changes can be transmitted to downstream secondaries as an incremental zone transfer.

By allowing incremental zone transfers to be used for non-dynamic zones, this option saves bandwidth at the expense of increased CPU and memory consumption at the primary server. In particular, if the new version of a zone is completely different from the previous one, the set of differences is of a size comparable to the combined size of the old and new zone versions, and the server needs to temporarily allocate memory to hold this complete difference set.

*ixfr-from-differences* also accepts *primary* and *secondary* at the view and options levels, which causes *ixfr-from-differences* to be enabled for all primary or secondary zones, respectively. It is off for all zones by default.

Note: if inline signing is enabled for a zone, the user-provided *ixfr-from-differences* setting is ignored for that zone.

**multi-master**

**Grammar:** `multi-master <boolean>;`

**Blocks:** options, view, zone (mirror, secondary, stub)

**Tags:** transfer

Controls whether serial number mismatch errors are logged.

This should be set when there are multiple primary servers for a zone and the addresses refer to different machines. If *yes*, *named* does not log when the serial number on the primary is less than what *named* currently has. The default is *no*.

**auto-dnssec**

 **Warning**

This option is deprecated and will be removed in a future version of BIND.

**Grammar:** `auto-dnssec ( allow | maintain | off ); // deprecated`

**Blocks:** options, view, zone (primary, secondary)

**Tags:** dnssec

Permits varying levels of automatic DNSSEC key management.

Zones configured for dynamic DNS may use this option to allow varying levels of automatic DNSSEC key management. There are three possible settings:

`auto-dnssec allow;` permits keys to be updated and the zone fully re-signed whenever the user issues the command `rndc sign zonename`.

`auto-dnssec maintain;` includes the above, but also automatically adjusts the zone's DNSSEC keys on a schedule, according to the keys' timing metadata (see *dnssec-keygen: DNSSEC key generation tool* and *dnssec-settime: set the key timing metadata for a DNSSEC key*). The command `rndc sign zonename` causes *named* to load keys from the key repository and sign the zone with all keys that are active. `rndc loadkeys zonename` causes *named* to load keys from the key repository and schedule key maintenance events to occur in the future, but it does not sign the full zone immediately. Note: once keys have been loaded for a zone the first time, the

repository is searched for changes periodically, regardless of whether `rndc loadkeys` is used. The recheck interval is defined by `dnssec-loadkeys-interval`.

`auto-dnssec off`; does not allow for DNSSEC key management. This is the default setting.

This option may only be activated at the zone level; if configured at the view or options level, it must be set to `off`.

The DNSSEC records are written to the zone's filename set in `file`, unless `inline-signing` is enabled.

#### **dnssec-validation**

**Grammar:** `dnssec-validation ( yes | no | auto );`

**Blocks:** options, view

**Tags:** dnssec

Enables DNSSEC validation in `named`.

This option enables DNSSEC validation in `named`.

If set to `auto`, DNSSEC validation is enabled and a default trust anchor for the DNS root zone is used. This trust anchor is provided as part of BIND and is kept up-to-date using *Dynamic Trust Anchor Management* key management.

If set to `yes`, DNSSEC validation is enabled, but a trust anchor must be manually configured using a `trust-anchors` statement (or the `managed-keys` or `trusted-keys` statements, both deprecated). If there is no configured trust anchor, validation does not take place.

If set to `no`, DNSSEC validation is disabled.

The default is `auto`, unless BIND is built with `configure --disable-auto-validation`, in which case the default is `yes`.

The default root trust anchor is stored in the file `bind.keys`. `named` loads that key at startup if `dnssec-validation` is set to `auto`. A copy of the file is installed along with BIND 9, and is current as of the release date. If the root key expires, a new copy of `bind.keys` can be downloaded from <https://www.isc.org/bind-keys>.

(To prevent problems if `bind.keys` is not found, the current trust anchor is also compiled in `named`. Relying on this is not recommended, however, as it requires `named` to be recompiled with a new key when the root key expires.)

#### **Note**

`named` loads *only* the root key from `bind.keys`. The file cannot be used to store keys for other zones. The root key in `bind.keys` is ignored if `dnssec-validation auto` is not in use.

Whenever the resolver sends out queries to an EDNS-compliant server, it always sets the DO bit indicating it can support DNSSEC responses, even if `dnssec-validation` is off.

#### **validate-except**

**Grammar:** `validate-except { <string>; ... };`

**Blocks:** options, view

**Tags:** dnssec

Specifies a list of domain names at and beneath which DNSSEC validation should not be performed.

This specifies a list of domain names at and beneath which DNSSEC validation should *not* be performed, regardless of the presence of a trust anchor at or above those names. This may be used, for example, when configuring a top-level domain intended only for local use, so that the lack of a secure delegation for that domain in the root zone does not cause validation failures. (This is similar to setting a negative trust anchor except that it is a permanent configuration, whereas negative trust anchors expire and are removed after a set period of time.)

**dnssec-accept-expired**

**Grammar:** `dnssec-accept-expired <boolean>;`

**Blocks:** options, view

**Tags:** dnssec

Instructs BIND 9 to accept expired DNSSEC signatures when validating.

This accepts expired signatures when verifying DNSSEC signatures. The default is `no`. Setting this option to `yes` leaves *named* vulnerable to replay attacks.

**querylog**

**Grammar:** `querylog <boolean>;`

**Blocks:** options

**Tags:** logging, server

Specifies whether query logging should be active when *named* first starts.

Query logging provides a complete log of all incoming queries and all query errors. This provides more insight into the server's activity, but with a cost to performance which may be significant on heavily loaded servers.

The *querylog* option specifies whether query logging should be active when *named* first starts. If *querylog* is not specified, then query logging is determined by the presence of the logging category *queries*. Please note that *rndc reconfig* and *rndc reload* have no effect on this option, so it cannot be changed once the server is running. However, query logging can be activated at runtime using the command `rndc querylog on`, or deactivated with `rndc querylog off`.

**check-names**

**Grammar zone (hint, mirror, primary, secondary, stub):** `check-names ( fail | warn | ignore );`

**Grammar options, view:** `check-names ( primary | master | secondary | slave | response ) ( fail | warn | ignore ); // may occur multiple times`

**Blocks:** options, view, zone (hint, mirror, primary, secondary, stub)

**Tags:** query, server

Restricts the character set and syntax of certain domain names in primary files and/or DNS responses received from the network.

This option is used to restrict the character set and syntax of certain domain names in primary files and/or DNS responses received from the network. The default varies according to usage area. For *type primary* zones the default is `fail`. For *type secondary* zones the default is `warn`. For answers received from the network (*response*), the default is `ignore`.

The rules for legal hostnames and mail domains are derived from **RFC 952** and **RFC 821** as modified by **RFC 1123**.

*check-names* applies to the owner names of A, AAAA, and MX records. It also applies to the domain names in the RDATA of NS, SOA, MX, and SRV records. It further applies to the RDATA of PTR records where the owner name indicates that it is a reverse lookup of a hostname (the owner name ends in IN-ADDR.ARPA, IP6.ARPA, or IP6.INT).

#### **check-dup-records**

**Grammar:** `check-dup-records ( fail | warn | ignore );`

**Blocks:** options, view, zone (primary)

**Tags:** dnssec, query

Checks primary zones for records that are treated as different by DNSSEC but are semantically equal in plain DNS.

This checks primary zones for records that are treated as different by DNSSEC but are semantically equal in plain DNS. The default is to `warn`. Other possible values are `fail` and `ignore`.

#### **check-mx**

**Grammar:** `check-mx ( fail | warn | ignore );`

**Blocks:** options, view, zone (primary)

**Tags:** zone

Checks whether an MX record appears to refer to an IP address.

This checks whether the MX record appears to refer to an IP address. The default is to `warn`. Other possible values are `fail` and `ignore`.

#### **check-wildcard**

**Grammar:** `check-wildcard <boolean>;`

**Blocks:** options, view, zone (primary)

**Tags:** zone

Checks for non-terminal wildcards.

This option is used to check for non-terminal wildcards. The use of non-terminal wildcards is almost always as a result of a lack of understanding of the wildcard-matching algorithm ([RFC 1034](#)). This option affects primary zones. The default (`yes`) is to check for non-terminal wildcards and issue a warning.

#### **check-integrity**

**Grammar:** `check-integrity <boolean>;`

**Blocks:** options, view, zone (primary)

**Tags:** zone

Performs post-load zone integrity checks on primary zones.

This performs post-load zone integrity checks on primary zones. It checks that MX and SRV records refer to address (A or AAAA) records and that glue address records exist for delegated zones. For MX and SRV records, only in-zone hostnames are checked (for out-of-zone hostnames, use *named-checkzone*). For NS records, only names below top-of-zone are checked (for out-of-zone names and glue consistency checks, use *named-checkzone*). The default is `yes`.

The use of the SPF record to publish Sender Policy Framework is deprecated, as the migration from using TXT records to SPF records was abandoned. Enabling this option also checks that a TXT Sender Policy Framework record exists (starts with "v=spf1") if there is an SPF record. Warnings are emitted if the TXT record does not exist; they can be suppressed with *check-spf*.

**check-mx-cname**

**Grammar:** `check-mx-cname ( fail | warn | ignore );`

**Blocks:** options, view, zone (primary)

**Tags:** zone

Sets the response to MX records that refer to CNAMEs.

If *check-integrity* is set, then fail, warn, or ignore MX records that refer to CNAMEs. The default is to warn.

**check-srv-cname**

**Grammar:** `check-srv-cname ( fail | warn | ignore );`

**Blocks:** options, view, zone (primary)

**Tags:** zone

Sets the response to SRV records that refer to CNAMEs.

If *check-integrity* is set, then fail, warn, or ignore SRV records that refer to CNAMEs. The default is to warn.

**check-sibling**

**Grammar:** `check-sibling <boolean>;`

**Blocks:** options, view, zone (primary)

**Tags:** zone

Specifies whether to check for sibling glue when performing integrity checks.

When performing integrity checks, also check that sibling glue exists. The default is *yes*.

**check-spf**

**Grammar:** `check-spf ( warn | ignore );`

**Blocks:** options, view, zone (primary)

**Tags:** zone

Specifies whether to check for a TXT Sender Policy Framework record, if an SPF record is present.

If *check-integrity* is set, check that there is a TXT Sender Policy Framework record present (starts with "v=spf1") if there is an SPF record present. The default is *warn*.

**zero-no-soa-ttl**

**Grammar:** `zero-no-soa-ttl <boolean>;`

**Blocks:** options, view, zone (mirror, primary, secondary)

**Tags:** zone, query, server

Specifies whether to set the time to live (TTL) of the SOA record to zero, when returning authoritative negative responses to SOA queries.

If *yes*, when returning authoritative negative responses to SOA queries, set the TTL of the SOA record returned in the authority section to zero. The default is *yes*.

#### **zero-no-soa-ttl-cache**

**Grammar:** `zero-no-soa-ttl-cache <boolean>;`

**Blocks:** options, view

**Tags:** zone, query, server

Sets the time to live (TTL) to zero when caching a negative response to an SOA query.

If *yes*, when caching a negative response to an SOA query set the TTL to zero. The default is *no*.

#### **update-check-ksk**

**Grammar:** `update-check-ksk <boolean>;`

**Blocks:** options, view, zone (primary, secondary)

**Tags:** zone, dnssec

Specifies whether to check the KSK bit to determine how a key should be used, when generating RRSIGs for a secure zone.

When set to the default value of *yes*, check the KSK bit in each key to determine how the key should be used when generating RRSIGs for a secure zone.

Ordinarily, zone-signing keys (that is, keys without the KSK bit set) are used to sign the entire zone, while key-signing keys (keys with the KSK bit set) are only used to sign the DNSKEY RRset at the zone apex. However, if this option is set to *no*, then the KSK bit is ignored; KSKs are treated as if they were ZSKs and are used to sign the entire zone. This is similar to the `dnssec-signzone -z` command-line option.

When this option is set to *yes*, there must be at least two active keys for every algorithm represented in the DNSKEY RRset: at least one KSK and one ZSK per algorithm. If there is any algorithm for which this requirement is not met, this option is ignored for that algorithm.

#### **dnssec-dnskey-kskonly**

**Grammar:** `dnssec-dnskey-kskonly <boolean>;`

**Blocks:** options, view, zone (primary, secondary)

**Tags:** dnssec

Specifies that only key-signing keys are used to sign the DNSKEY, CDNSKEY, and CDS RRsets at a zone's apex.

When this option and `update-check-ksk` are both set to *yes*, only key-signing keys (that is, keys with the KSK bit set) are used to sign the DNSKEY, CDNSKEY, and CDS RRsets at the zone apex. Zone-signing keys (keys without the KSK bit set) are used to sign the remainder of the zone, but not the DNSKEY RRset. This is similar to the `dnssec-signzone -x` command-line option.

The default is *yes*. If `update-check-ksk` is set to *no*, this option is ignored.

**try-tcp-refresh****Grammar:** `try-tcp-refresh <boolean>;`**Blocks:** options, view, zone (mirror, secondary)**Tags:** transfer

Specifies that BIND 9 should attempt to refresh a zone using TCP if UDP queries fail.

If `yes`, try to refresh the zone using TCP if UDP queries fail. The default is `yes`.

**dnssec-secure-to-insecure****Grammar:** `dnssec-secure-to-insecure <boolean>;`**Blocks:** options, view, zone (primary)**Tags:** dnssec

Allows a dynamic zone to transition from secure to insecure by deleting all DNSKEY records.

This allows a dynamic zone to transition from secure to insecure (i.e., signed to unsigned) by deleting all of the DNSKEY records. The default is `no`. If set to `yes`, and if the DNSKEY RRset at the zone apex is deleted, all RRSIG and NSEC records are removed from the zone as well.

If the zone uses NSEC3, it is also necessary to delete the NSEC3PARAM RRset from the zone apex; this causes the removal of all corresponding NSEC3 records. (It is expected that this requirement will be eliminated in a future release.)

Note that if a zone has been configured with `auto-dnssec maintain` and the private keys remain accessible in the key repository, the zone will be automatically signed again the next time `named` is started.

**synth-from-dnssec****Grammar:** `synth-from-dnssec <boolean>;`**Blocks:** options, view**Tags:** dnssec

Enables support for [RFC 8198](#), Aggressive Use of DNSSEC-Validated Cache.

This option enables support for [RFC 8198](#), Aggressive Use of DNSSEC-Validated Cache. It allows the resolver to send a smaller number of queries when resolving queries for DNSSEC-signed domains by synthesizing answers from cached NSEC and other RRsets that have been proved to be correct using DNSSEC. The default is `yes`.

**Note**

DNSSEC validation must be enabled for this option to be effective. This initial implementation only covers synthesis of answers from NSEC records; synthesis from NSEC3 is planned for the future. This will also be controlled by `synth-from-dnssec`.

**Forwarding**

The forwarding facility sends queries which cannot be answered using local data to different resolvers. This can be used to create a large site-wide cache on a few servers, reducing traffic over links to external name servers. It can also be used to allow queries by servers that do not have direct access to the Internet, but wish to look up exterior names anyway.

Forwarding occurs only on those queries for which the server is not authoritative and does not have the answer in its cache.

#### **forward**

**Grammar:** `forward ( first | only );`

**Blocks:** options, view, zone (forward, primary, secondary, static-stub, stub)

**Tags:** query

Allows or disallows fallback to recursion if forwarding has failed; it is always used in conjunction with the *forwarders* statement.

This option is only meaningful if the *forwarders* list is not empty. A value of *first* is the default and causes the server to query the forwarders first; if that does not answer the question, the server then looks for the answer itself. If *only* is specified, the server only queries the forwarders.

#### **forwarders**

**Grammar:** `forwarders [ port <integer> ] { ( <ipv4_address> | <ipv6_address> ) [ port <integer> ]; ... };`

**Blocks:** options, view, zone (forward, primary, secondary, static-stub, stub)

**Tags:** query

Defines one or more resolvers to which queries are forwarded.

This specifies a list of IP addresses of DNS resolvers, to which queries which cannot be answered using locally available data are forwarded. The default is the empty list (no forwarding). Each address in the list can be associated with an optional port number. A default port number can be set for the entire list.

Forwarding can also be configured on a per-domain basis, allowing for the global forwarding options to be overridden in a variety of ways. Particular domains can be set to use different forwarders, or have a different *forward only/first* behavior, or not forward at all; see *zone*.

## Dual-stack Servers

Dual-stack servers are used as servers of last resort, to work around problems in reachability due to the lack of support for either IPv4 or IPv6 on the host machine.

#### **dual-stack-servers**

**Grammar:** `dual-stack-servers [ port <integer> ] { ( <quoted_string> [ port <integer> ] | <ipv4_address> [ port <integer> ] | <ipv6_address> [ port <integer> ] ); ... };`

**Blocks:** options, view

**Tags:** server

Specifies host names or addresses of machines with access to both IPv4 and IPv6 transports.

This specifies host names or addresses of machines with access to both IPv4 and IPv6 transports. If a hostname is used, the server must be able to resolve the name using only the transport it has. If the machine is dual-stacked, the *dual-stack-servers* parameter has no effect unless access to a transport has been disabled on the command line (e.g., *named -4*).

## Access Control

Access to the server can be restricted based on the IP address of the requesting system. See *Address Match Lists* for details on how to specify IP address lists.

### allow-notify

**Grammar:** `allow-notify { <address_match_element>; ... };`

**Blocks:** options, view, zone (mirror, secondary)

**Tags:** transfer

Defines an *address\_match\_list* that is allowed to send NOTIFY messages for the zone, in addition to addresses defined in the *primaries* option for the zone.

This ACL specifies which hosts may send NOTIFY messages to inform this server of changes to zones for which it is acting as a secondary server. This is only applicable for secondary zones (i.e., *type secondary* or *slave*).

If this option is set in *view* or *options*, it is globally applied to all secondary zones. If set in the *zone* statement, the global value is overridden.

If not specified, the default is to process NOTIFY messages only from the configured *primaries* for the zone. *allow-notify* can be used to expand the list of permitted hosts, not to reduce it.

### allow-query

**Grammar:** `allow-query { <address_match_element>; ... };`

**Blocks:** options, view, zone (mirror, primary, redirect, secondary, static-stub, stub)

**Tags:** query

Specifies which hosts (an IP address list) are allowed to send queries to this resolver.

*allow-query* may also be specified in the *zone* statement, in which case it overrides the *options allow-query* statement. If not specified, the default is to allow queries from all hosts.

#### Note

*allow-query-cache* is used to specify access to the cache.

### allow-query-on

**Grammar:** `allow-query-on { <address_match_element>; ... };`

**Blocks:** options, view, zone (mirror, primary, redirect, secondary, static-stub, stub)

**Tags:** query

Specifies which local addresses (an IP address list) are allowed to send queries to this resolver. Used in multi-homed configurations.

This makes it possible, for instance, to allow queries on internal-facing interfaces but disallow them on external-facing ones, without necessarily knowing the internal network's addresses.

Note that *allow-query-on* is only checked for queries that are permitted by *allow-query*. A query must be allowed by both ACLs, or it is refused.

*allow-query-on* may also be specified in the *zone* statement, in which case it overrides the options *allow-query-on* statement.

If not specified, the default is to allow queries on all addresses.

**Note**

*allow-query-cache* is used to specify access to the cache.

**allow-query-cache**

**Grammar:** `allow-query-cache { <address_match_element>; ... };`

**Blocks:** options, view

**Tags:** query

Specifies which hosts (an IP address list) can access this server's cache and thus effectively controls recursion.

Defines an *address\_match\_list* of IP address(es) which are allowed to issue queries that access the local cache. Without access to the local cache recursive queries are effectively useless so, in effect, this statement (or its default) controls recursive behavior. This statement's default setting depends on:

1. If *recursion no*; present, defaults to `allow-query-cache {none;};`. No local cache access permitted.
2. If *recursion yes*; (default) then, if *allow-recursion* present, defaults to the value of *allow-recursion*. Local cache access permitted to the same *address\_match\_list* as *allow-recursion*.
3. If *recursion yes*; (default) then, if *allow-recursion* is **not** present, defaults to `allow-query-cache {localnets; localhost;};`. Local cache access permitted to *address\_match\_list* localnets and localhost IP addresses only.

**allow-query-cache-on**

**Grammar:** `allow-query-cache-on { <address_match_element>; ... };`

**Blocks:** options, view

**Tags:** query

Specifies which hosts (an IP address list) can access this server's cache. Used on servers with multiple interfaces.

This specifies which local addresses can send answers from the cache. If *allow-query-cache-on* is not set, then *allow-recursion-on* is used if set. Otherwise, the default is to allow cache responses to be sent from any address. Note: both *allow-query-cache* and *allow-query-cache-on* must be satisfied before a cache response can be sent; a client that is blocked by one cannot be allowed by the other.

**allow-recursion**

**Grammar:** `allow-recursion { <address_match_element>; ... };`

**Blocks:** options, view

**Tags:** query

Defines an *address\_match\_list* of clients that are allowed to perform recursive queries.

This specifies which hosts are allowed to make recursive queries through this server. BIND checks to see if the following parameters are set, in order: *allow-query-cache* and *allow-query*. If neither of those parameters is set, the default (localnets; localhost;) is used.

**allow-recursion-on**

**Grammar:** `allow-recursion-on { <address_match_element>; ... };`

**Blocks:** options, view

**Tags:** query, server

Specifies which local addresses can accept recursive queries.

This specifies which local addresses can accept recursive queries. If `allow-recursion-on` is not set, then `allow-query-cache-on` is used if set; otherwise, the default is to allow recursive queries on all addresses. Any client permitted to send recursive queries can send them to any address on which `named` is listening. Note: both `allow-recursion` and `allow-recursion-on` must be satisfied before recursion is allowed; a client that is blocked by one cannot be allowed by the other.

**allow-update**

**Grammar:** `allow-update { <address_match_element>; ... };`

**Blocks:** options, view, zone (primary)

**Tags:** transfer

Defines an `address_match_list` of hosts that are allowed to submit dynamic updates for primary zones.

A simple access control list. When set in the `zone` statement for a primary zone, this specifies which hosts are allowed to submit dynamic DNS updates to that zone. The default is to deny updates from all hosts.

Note that allowing updates based on the requestor's IP address is insecure; see *Dynamic Update Security* for details.

In general, this option should only be set at the `zone` level. While a default value can be set at the `options` or `view` level and inherited by zones, this could lead to some zones unintentionally allowing updates.

Updates are written to the zone's filename that is set in `file`.

**allow-update-forwarding**

**Grammar:** `allow-update-forwarding { <address_match_element>; ... };`

**Blocks:** options, view, zone (mirror, secondary)

**Tags:** transfer

Defines an `address_match_list` of hosts that are allowed to submit dynamic updates to a secondary server for transmission to a primary.

When set in the `zone` statement for a secondary zone, this specifies which hosts are allowed to submit dynamic DNS updates and have them be forwarded to the primary. The default is `{ none; }`, which means that no update forwarding is performed.

To enable update forwarding, specify `allow-update-forwarding { any; }` in the `zone` statement. Specifying values other than `{ none; }` or `{ any; }` is usually counterproductive; the responsibility for update access control should rest with the primary server, not the secondary.

Note that enabling the update forwarding feature on a secondary server may expose primary servers to attacks if they rely on insecure IP-address-based access control; see *Dynamic Update Security* for more details.

In general this option should only be set at the `zone` level. While a default value can be set at the `options` or `view` level and inherited by zones, this can lead to some zones unintentionally forwarding updates.

**allow-transfer**

**Grammar:** `allow-transfer [ port <integer> ] [ transport <string> ] { <address_match_element>; ... };`

**Blocks:** options, view, zone (mirror, primary, secondary)

**Tags:** transfer

Defines an *address\_match\_list* of hosts that are allowed to transfer the zone information from this server.

This specifies which hosts are allowed to receive zone transfers from the server. *allow-transfer* may also be specified in the *zone* statement, in which case it overrides the *allow-transfer* statement set in *options* or *view*. If not specified, the default is to allow transfers to all hosts.

The transport level limitations can also be specified. In particular, zone transfers can be restricted to a specific port and/or DNS transport protocol by using the options *port* and *transport*. Either option can be specified; if both are used, both constraints must be satisfied in order for the transfer to be allowed. Zone transfers are currently only possible via the TCP and TLS transports.

For example: `allow-transfer port 853 transport tls { any; };` allows outgoing zone transfers to any host using the TLS transport over port 853.

 **Warning**

Please note that incoming TLS connections are **not authenticated at the TLS level by default**. Please use *TSIG* to authenticate requestors or consider implementing *Mutual TLS* authentication.

**blackhole**

**Grammar:** `blackhole { <address_match_element>; ... };`

**Blocks:** options

**Tags:** query

Defines an *address\_match\_list* of hosts to ignore. The server will neither respond to queries from nor send queries to these addresses.

This specifies a list of addresses which the server does not accept queries from or use to resolve a query. Queries from these addresses are not responded to. The default is *none*.

When configuring this list, note that BIND evaluates Access Control Lists sequentially (first match wins). A common misconception is that the directive `!address;` blocks everything except that address. In reality, it only explicitly exempts *address* from the blackhole; all other IP addresses reach the end of the list without matching, meaning they are also not blackholed.

To successfully blackhole all traffic *except* specific addresses, you must explicitly catch the remaining traffic with `any;` at the end of the list. For example: `!address; any;`

**keep-response-order**

**Grammar:** `keep-response-order { <address_match_element>; ... };`

**Blocks:** options

**Tags:** server

Defines an *address\_match\_list* of addresses which do not accept reordered answers within a single TCP stream.

This specifies a list of addresses to which the server sends responses to TCP queries, in the same order in which they were received. This disables the processing of TCP queries in parallel. The default is *none*.

**no-case-compress**

**Grammar:** `no-case-compress { <address_match_element>; ... };`

**Blocks:** options, view

**Tags:** server

Specifies a list of addresses that require case-insensitive compression in responses.

This specifies a list of addresses which require responses to use case-insensitive compression. This ACL can be used when *named* needs to work with clients that do not comply with the requirement in **RFC 1034** to use case-insensitive name comparisons when checking for matching domain names.

If left undefined, the ACL defaults to *none*: case-sensitive compression is used for all clients. If the ACL is defined and matches a client, case is ignored when compressing domain names in DNS responses sent to that client.

This can result in slightly smaller responses; if a response contains the names "example.com" and "example.COM", case-insensitive compression treats the second one as a duplicate. It also ensures that the case of the query name exactly matches the case of the owner names of returned records, rather than matches the case of the records entered in the zone file. This allows responses to exactly match the query, which is required by some clients due to incorrect use of case-sensitive comparisons.

Case-insensitive compression is *always* used in AXFR and IXFR responses, regardless of whether the client matches this ACL.

There are circumstances in which *named* does not preserve the case of owner names of records: if a zone file defines records of different types with the same name, but the capitalization of the name is different (e.g., "www.example.com/A" and "WWW.EXAMPLE.COM/AAAA"), then all responses for that name use the *first* version of the name that was used in the zone file. This limitation may be addressed in a future release. However, domain names specified in the rdata of resource records (i.e., records of type NS, MX, CNAME, etc.) always have their case preserved unless the client matches this ACL.

**resolver-query-timeout**

**Grammar:** `resolver-query-timeout <integer>;`

**Blocks:** options, view

**Tags:** query

Specifies the length of time, in milliseconds, that a resolver attempts to resolve a recursive query before failing.

This is the amount of time in milliseconds that the resolver spends attempting to resolve a recursive query before failing. The default and minimum is 10000 and the maximum is 30000. Setting it to 0 results in the default being used.

This value was originally specified in seconds. Values less than or equal to 300 are treated as seconds and converted to milliseconds before applying the above limits.

## Interfaces

The interfaces, ports, and protocols that the server can use to answer queries may be specified using the *listen-on* and *listen-on-v6* options.

### **listen-on**

**Grammar:** `listen-on [ port <integer> ] [ tls <string> ] [ http <string> ] { <address_match_element>; ... }; // may occur multiple times`

**Blocks:** options

**Tags:** server

Specifies the IPv4 addresses on which a server listens for DNS queries.

### **listen-on-v6**

**Grammar:** `listen-on-v6 [ port <integer> ] [ tls <string> ] [ http <string> ] { <address_match_element>; ... }; // may occur multiple times`

**Blocks:** options

**Tags:** server

Specifies the IPv6 addresses on which a server listens for DNS queries.

The *listen-on* and *listen-on-v6* statements can each take an optional port, TLS configuration identifier, and/or HTTP configuration identifier, in addition to an *address\_match\_list*.

The *address\_match\_list* in *listen-on* specifies the IPv4 addresses on which the server will listen. (IPv6 addresses are ignored, with a logged warning.) The server listens on all interfaces allowed by the address match list. If no *listen-on* is specified, the default is to listen for standard DNS queries on port 53 of all IPv4 interfaces.

*listen-on-v6* takes an *address\_match\_list* of IPv6 addresses. The server listens on all interfaces allowed by the address match list. If no *listen-on-v6* is specified, the default is to listen for standard DNS queries on port 53 of all IPv6 interfaces.

If a TLS configuration is specified, *named* will listen for DNS-over-TLS (DoT) connections, using the key and certificate specified in the referenced *tls* statement. If the name *ephemeral* is used, an ephemeral key and certificate created for the currently running *named* process will be used.

If an HTTP configuration is specified, *named* will listen for DNS-over-HTTPS (DoH) connections using the HTTP endpoint specified in the referenced *http* statement. If the name *default* is used, then *named* will listen for connections at the default endpoint, */dns-query*.

Use of an *http* specification requires *tls* to be specified as well. If an unencrypted connection is desired (for example, on load-sharing servers behind a reverse proxy), *tls none* may be used.

If a port number is not specified, the default is 53 for standard DNS, 853 for DNS over TLS, 443 for DNS over HTTPS, and 80 for DNS over HTTP (unencrypted). These defaults may be overridden using the *port*, *tls-port*, *https-port*, and *http-port* options.

Multiple *listen-on* statements are allowed. For example:

```
listen-on { 5.6.7.8; };
listen-on port 1234 { !1.2.3.4; 1.2/16; };
listen-on port 8853 tls ephemeral { 4.3.2.1; };
listen-on port 8453 tls ephemeral http myserver { 8.7.6.5; };
```

The first two lines instruct the name server to listen for standard DNS queries on port 53 of the IP address 5.6.7.8 and on port 1234 of an address on the machine in net 1.2 that is not 1.2.3.4. The third line instructs the server to listen for DNS-over-TLS connections on port 8853 of the IP address 4.3.2.1 using the ephemeral key and certificate. The fourth line enables DNS-over-HTTPS connections on port 8453 of address 8.7.6.5, using the ephemeral key and certificate, and the HTTP endpoint or endpoints configured in an `http` statement with the name `myserver`.

Multiple `listen-on-v6` options can be used. For example:

```
listen-on-v6 { any; };
listen-on-v6 port 1234 { !2001:db8::/32; any; };
listen-on port 8853 tls example-tls { 2001:db8::100; };
listen-on port 8453 tls example-tls http default { 2001:db8::100; };
listen-on port 8000 tls none http myserver { 2001:db8::100; };
```

The first two lines instruct the name server to listen for standard DNS queries on port 53 of any IPv6 addresses, and on port 1234 of IPv6 addresses that are not in the prefix 2001:db8::/32. The third line instructs the server to listen for for DNS-over-TLS connections on port 8853 of the address 2001:db8::100, using a TLS key and certificate specified in the a `tls` statement with the name `example-tls`. The fourth instructs the server to listen for DNS-over-HTTPS connections, again using `example-tls`, on the default HTTP endpoint. The fifth line, in which the `tls` parameter is set to `none`, instructs the server to listen for *unencrypted* DNS queries over HTTP at the endpoint specified in `myserver`.

To instruct the server not to listen on any IPv6 addresses, use:

```
listen-on-v6 { none; };
```

## Query Address

### `query-source`

**Grammar:** `query-source [ address ] ( <ipv4_address> | * );`

**Blocks:** options, server, view, view.server

**Tags:** query

Controls the IPv4 address from which queries are issued.

### `query-source-v6`

**Grammar:** `query-source-v6 [ address ] ( <ipv6_address> | * );`

**Blocks:** options, server, view, view.server

**Tags:** query

Controls the IPv6 address from which queries are issued.

If the server does not know the answer to a question, it queries other name servers. `query-source` specifies the address and port used for such queries. For queries sent over IPv6, there is a separate `query-source-v6` option. If `address` is `*` (asterisk) or is omitted, a wildcard IP address (`INADDR_ANY`) is used.

The defaults of the `query-source` and `query-source-v6` options are:

```
query-source address * port *;
query-source-v6 address * port *;
```

**Note**

`port` configuration is deprecated. A warning will be logged when this parameter is used.

**Note**

The address specified in the `query-source` option is used for both UDP and TCP queries, but the port applies only to UDP queries. TCP queries always use a random unprivileged port.

**use-v4-udp-ports****Warning**

This option is deprecated and will be removed in a future version of BIND.

**Grammar:** `use-v4-udp-ports { <portrange>; ... }; // deprecated`

**Blocks:** options

**Tags:** deprecated

Specifies a list of ports that are valid sources for UDP/IPv4 messages.

**use-v6-udp-ports****Warning**

This option is deprecated and will be removed in a future version of BIND.

**Grammar:** `use-v6-udp-ports { <portrange>; ... }; // deprecated`

**Blocks:** options

**Tags:** deprecated

Specifies a list of ports that are valid sources for UDP/IPv6 messages.

These statements, which are deprecated and will be removed in a future release, specify a list of IPv4 and IPv6 UDP ports that are used as source ports for UDP messages.

If `port` is `*` or is omitted, a random port number from a pre-configured range is selected and used for each query. The port range(s) are specified in the `use-v4-udp-ports` (for IPv4) and `use-v6-udp-ports` (for IPv6) options.

If `use-v4-udp-ports` or `use-v6-udp-ports` is unspecified, `named` checks whether the operating system provides a programming interface to retrieve the system's default range for ephemeral ports. If such an interface is available, `named` uses the corresponding system default range; otherwise, it uses its own defaults:

```
use-v4-udp-ports { range 1024 65535; };
use-v6-udp-ports { range 1024 65535; };
```

**avoid-v4-udp-ports**

**Warning**

This option is deprecated and will be removed in a future version of BIND.

**Grammar:** `avoid-v4-udp-ports { <portrange>; ... }; // deprecated`

**Blocks:** options

**Tags:** deprecated

Specifies the range(s) of ports to be excluded from use as sources for UDP/IPv4 messages.

**avoid-v6-udp-ports**

**Warning**

This option is deprecated and will be removed in a future version of BIND.

**Grammar:** `avoid-v6-udp-ports { <portrange>; ... }; // deprecated`

**Blocks:** options

**Tags:** deprecated

Specifies the range(s) of ports to be excluded from use as sources for UDP/IPv6 messages.

These statements, which are deprecated and will be removed in a future release, indicate ranges of port numbers to exclude from those specified in the `avoid-v4-udp-ports` and `avoid-v6-udp-ports` options, respectively.

The defaults of the `avoid-v4-udp-ports` and `avoid-v6-udp-ports` options are:

```
avoid-v4-udp-ports {};
avoid-v6-udp-ports {};
```

For example, with the following configuration:

```
use-v6-udp-ports { range 32768 65535; };
avoid-v6-udp-ports { 40000; range 50000 60000; };
```

UDP ports of IPv6 messages sent from `named` are in one of the following ranges: 32768 to 39999, 40001 to 49999, or 60001 to 65535.

`avoid-v4-udp-ports` and `avoid-v6-udp-ports` can be used to prevent `named` from choosing as its random source port a port that is blocked by a firewall or that is used by other applications; if a query went out with a source port blocked by a firewall, the answer would not pass through the firewall and the name server would have to query again. Note: the desired range can also be represented only with `use-v4-udp-ports` and `use-v6-udp-ports`, and the `avoid-` options are redundant in that sense; they are provided for backward compatibility and to possibly simplify the port specification.

**Note**

Make sure the ranges are sufficiently large for security. A desirable size depends on several parameters, but we generally recommend it contain at least 16384 ports (14 bits of entropy). Note also that the system's default range when used may be too small for this purpose, and that the range may even be changed while *named* is running; the new range is automatically applied when *named* is reloaded. Explicit configuration of *use-v4-udp-ports* and *use-v6-udp-ports* is encouraged, so that the ranges are sufficiently large and are reasonably independent from the ranges used by other applications.

**Note**

The operational configuration where *named* runs may prohibit the use of some ports. For example, Unix systems do not allow *named*, if run without root privilege, to use ports less than 1024. If such ports are included in the specified (or detected) set of query ports, the corresponding query attempts will fail, resulting in resolution failures or delay. It is therefore important to configure the set of ports that can be safely used in the expected operational environment.

**Warning**

Specifying a single port is discouraged, as it removes a layer of protection against spoofing errors.

**Warning**

The configured *port* must not be the same as the listening port.

**Note**

See also *transfer-source*, *notify-source* and *parental-source*.

## Zone Transfers

BIND has mechanisms in place to facilitate zone transfers and set limits on the amount of load that transfers place on the system. The following options apply to zone transfers.

### **also-notify**

**Grammar:** `also-notify [ port <integer> ] { ( <remote-servers> | <ipv4_address> [ port <integer> ] | <ipv6_address> [ port <integer> ] ) [ key <string> ] [ tls <string> ]; ... };`

**Blocks:** options, view, zone (mirror, primary, secondary)

**Tags:** transfer

Defines one or more hosts that are sent NOTIFY messages when zone changes occur.

This option defines a global list of IP addresses of name servers that are also sent NOTIFY messages whenever a fresh copy of the zone is loaded, in addition to the servers listed in the zone's NS records. This helps to ensure that copies of the zones quickly converge on stealth servers. Optionally, a port may be specified with each

*also-notify* address to send the notify messages to a port other than the default of 53. An optional TSIG key can also be specified with each address to cause the notify messages to be signed; this can be useful when sending notifies to multiple views. In place of explicit addresses, one or more named *primaries* lists can be used.

If an *also-notify* list is given in a *zone* statement, it overrides the options *also-notify* statement. When a *zone notify* statement is set to *no*, the IP addresses in the global *also-notify* list are not sent NOTIFY messages for that zone. The default is the empty list (no global notification list).

**max-transfer-time-in**

**Grammar:** `max-transfer-time-in <integer>;`

**Blocks:** options, view, zone (mirror, secondary, stub)

**Tags:** transfer

Specifies the number of minutes after which inbound zone transfers are terminated.

Inbound zone transfers running longer than this many minutes are terminated. The default is 120 minutes (2 hours). The maximum value is 28 days (40320 minutes).

**max-transfer-idle-in**

**Grammar:** `max-transfer-idle-in <integer>;`

**Blocks:** options, view, zone (mirror, secondary, stub)

**Tags:** transfer

Specifies the number of minutes after which inbound zone transfers making no progress are terminated.

Inbound zone transfers making no progress in this many minutes are terminated. The default is 60 minutes (1 hour). The maximum value is 28 days (40320 minutes).

**Note**

Inbound zone transfers are also affected by `tcp-idle-timeout`; `max-transfer-idle-in` closes the inbound zone transfer if there is no complete AXFR or no complete IXFR chunk. `tcp-idle-timeout` closes the connection if there is no progress on the TCP level.

**max-transfer-time-out**

**Grammar:** `max-transfer-time-out <integer>;`

**Blocks:** options, view, zone (mirror, primary, secondary)

**Tags:** transfer

Specifies the number of minutes after which outbound zone transfers are terminated.

Outbound zone transfers running longer than this many minutes are terminated. The default is 120 minutes (2 hours). The maximum value is 28 days (40320 minutes).

**max-transfer-idle-out**

**Grammar:** `max-transfer-idle-out <integer>;`

**Blocks:** options, view, zone (mirror, primary, secondary)

**Tags:** transfer

Specifies the number of minutes after which outbound zone transfers making no progress are terminated.

Outbound zone transfers making no progress in this many minutes are terminated. The default is 60 minutes (1 hour). The maximum value is 28 days (40320 minutes).

**notify-rate**

**Grammar:** `notify-rate <integer>;`

**Blocks:** options

**Tags:** transfer, zone

Specifies the rate at which NOTIFY requests are sent during normal zone maintenance operations.

This specifies the rate at which NOTIFY requests are sent during normal zone maintenance operations. (NOTIFY requests due to initial zone loading are subject to a separate rate limit; see below.) The default is 20 per second. The lowest possible rate is one per second; when set to zero, it is silently raised to one.

**startup-notify-rate**

**Grammar:** `startup-notify-rate <integer>;`

**Blocks:** options

**Tags:** transfer, zone

Specifies the rate at which NOTIFY requests are sent when the name server is first starting, or when new zones have been added.

This is the rate at which NOTIFY requests are sent when the name server is first starting up, or when zones have been newly added to the name server. The default is 20 per second. The lowest possible rate is one per second; when set to zero, it is silently raised to one.

**serial-query-rate**

**Grammar:** `serial-query-rate <integer>;`

**Blocks:** options

**Tags:** transfer

Defines an upper limit on the number of queries per second issued by the server, when querying the SOA RRs used for zone transfers.

Secondary servers periodically query primary servers to find out if zone serial numbers have changed. Each such query uses a minute amount of the secondary server's network bandwidth. To limit the amount of bandwidth used, BIND 9 limits the rate at which queries are sent. The value of the *serial-query-rate* option, an integer, is the maximum number of queries sent per second. The default is 20 per second. The lowest possible rate is one per second; when set to zero, it is silently raised to one.

**transfer-format**

**Grammar:** `transfer-format ( many-answers | one-answer );`

**Blocks:** options, server, view, view.server

**Tags:** transfer

Controls whether multiple records can be packed into a message during zone transfers.

Zone transfers can be sent using two different formats, `one-answer` and `many-answers`. The `transfer-format` option is used on the primary server to determine which format it sends. `one-answer` uses one DNS message per resource record transferred. `many-answers` packs as many resource records as possible into one message. `many-answers` is more efficient; the default is `many-answers`. `transfer-format` may be overridden on a per-server basis by using the `server` block.

**transfer-message-size**

**Grammar:** `transfer-message-size <integer>;`

**Blocks:** options

**Tags:** transfer

Limits the uncompressed size of DNS messages used in zone transfers over TCP.

This is an upper bound on the uncompressed size of DNS messages used in zone transfers over TCP. If a message grows larger than this size, additional messages are used to complete the zone transfer. (Note, however, that this is a hint, not a hard limit; if a message contains a single resource record whose RDATA does not fit within the size limit, a larger message will be permitted so the record can be transferred.)

Valid values are between 512 and 65535 octets; any values outside that range are adjusted to the nearest value within it. The default is 20480, which was selected to improve message compression; most DNS messages of this size will compress to less than 16536 bytes. Larger messages cannot be compressed as effectively, because 16536 is the largest permissible compression offset pointer in a DNS message.

This option is mainly intended for server testing; there is rarely any benefit in setting a value other than the default.

**transfers-in**

**Grammar:** `transfers-in <integer>;`

**Blocks:** options

**Tags:** transfer

Limits the number of concurrent inbound zone transfers.

This is the maximum number of inbound zone transfers that can run concurrently. The default value is 10. Increasing `transfers-in` may speed up the convergence of secondary zones, but it also may increase the load on the local system.

**transfers-out**

**Grammar:** `transfers-out <integer>;`

**Blocks:** options

**Tags:** transfer

Limits the number of concurrent outbound zone transfers.

This is the maximum number of outbound zone transfers that can run concurrently. Zone transfer requests in excess of the limit are refused. The default value is 10.

**transfers-per-ns**

**Grammar:** `transfers-per-ns <integer>;`

**Blocks:** options

**Tags:** transfer

Limits the number of concurrent inbound zone transfers from a remote server.

This is the maximum number of inbound zone transfers that can concurrently transfer from a given remote name server. The default value is 2. Increasing *transfers-per-ns* may speed up the convergence of secondary zones, but it also may increase the load on the remote name server. *transfers-per-ns* may be overridden on a per-server basis by using the *transfers* phrase of the *server* statement.

#### **transfer-source**

**Grammar:** `transfer-source ( <ipv4_address> | * );`

**Blocks:** options, server, view, zone (mirror, secondary, stub), view.server

**Tags:** transfer

Defines which local IPv4 address(es) are bound to TCP connections used to fetch zones transferred inbound by the server.

*transfer-source* determines which local address is bound to IPv4 TCP connections used to fetch zones transferred inbound by the server. It also determines the source IPv4 address, and optionally the UDP port, used for the refresh queries and forwarded dynamic updates. If not set, it defaults to a system-controlled value which is usually the address of the interface "closest to" the remote end. This address must appear in the remote end's *allow-transfer* option for the zone being transferred, if one is specified. This statement sets the *transfer-source* for all zones, but can be overridden on a per-view or per-zone basis by including a *transfer-source* statement within the *view* or *zone* block in the configuration file.

#### **Note**

`port` configuration is deprecated. A warning will be logged when this parameter is used.

#### **Warning**

Specifying a single port is discouraged, as it removes a layer of protection against spoofing errors.

#### **Warning**

The configured *port* must not be the same as the listening port.

#### **transfer-source-v6**

**Grammar:** `transfer-source-v6 ( <ipv6_address> | * );`

**Blocks:** options, server, view, zone (mirror, secondary, stub), view.server

**Tags:** transfer

Defines which local IPv6 address(es) are bound to TCP connections used to fetch zones transferred inbound by the server.

This option is the same as *transfer-source*, except zone transfers are performed using IPv6.

### alt-transfer-source

 **Warning**

This option is deprecated and will be removed in a future version of BIND.

**Grammar:** alt-transfer-source ( <ipv4\_address> | \* ); // deprecated

**Blocks:** options, view, zone (mirror, primary, secondary)

**Tags:** deprecated

Defines alternate local IPv4 address(es) to be used by the server for inbound zone transfers, if the address(es) defined by *transfer-source* fail and *use-alt-transfer-source* is enabled.

This indicates an alternate transfer source if the one listed in *transfer-source* fails and *use-alt-transfer-source* is set.

 **Note**

To avoid using the alternate transfer source, set *use-alt-transfer-source* appropriately and do not depend upon getting an answer back to the first refresh query.

### alt-transfer-source-v6

 **Warning**

This option is deprecated and will be removed in a future version of BIND.

**Grammar:** alt-transfer-source-v6 ( <ipv6\_address> | \* ); // deprecated

**Blocks:** options, view, zone (mirror, primary, secondary)

**Tags:** deprecated

Defines alternate local IPv6 address(es) to be used by the server for inbound zone transfers.

This indicates an alternate transfer source if the one listed in *transfer-source-v6* fails and *use-alt-transfer-source* is set.

### use-alt-transfer-source

 **Warning**

This option is deprecated and will be removed in a future version of BIND.

**Grammar:** use-alt-transfer-source <boolean>; // deprecated

**Blocks:** options, view, zone (mirror, secondary, stub)

**Tags:** deprecated

Indicates whether *alt-transfer-source* and *alt-transfer-source-v6* can be used.

This indicates whether the alternate transfer sources should be used. If views are specified, this defaults to `no`; otherwise, it defaults to `yes`.

#### `notify-source`

**Grammar:** `notify-source ( <ipv4_address> | * );`

**Blocks:** options, server, view, zone (mirror, primary, secondary), view.server

**Tags:** transfer

Defines the IPv4 address (and optional port) to be used for outgoing NOTIFY messages.

*notify-source* determines which local source address, and optionally UDP port, is used to send NOTIFY messages. This address must appear in the secondary server's *primaries* zone clause or in an *allow-notify* clause. This statement sets the *notify-source* for all zones, but can be overridden on a per-zone or per-view basis by including a *notify-source* statement within the *zone* or *view* block in the configuration file.

#### Note

`port` configuration is deprecated. A warning will be logged when this parameter is used.

#### Warning

Specifying a single port is discouraged, as it removes a layer of protection against spoofing errors.

#### Warning

The configured *port* must not be the same as the listening port.

#### `notify-source-v6`

**Grammar:** `notify-source-v6 ( <ipv6_address> | * );`

**Blocks:** options, server, view, zone (mirror, primary, secondary), view.server

**Tags:** transfer

Defines the IPv6 address (and optional port) to be used for outgoing NOTIFY messages.

This option acts like *notify-source*, but applies to NOTIFY messages sent to IPv6 addresses.

## Operating System Resource Limits

The server's usage of many system resources can be limited. Scaled values are allowed when specifying resource limits. For example, 1G can be used instead of 1073741824 to specify a limit of one gigabyte. `unlimited` requests unlimited use, or the maximum available amount. `default` uses the limit that was in force when the server was started. See the description of *size*.

The following options are deprecated in favor of setting the operating system resource limits from the operating system and/or process supervisor. They should not be used and will be rendered non-operational in a future release.

**coresize**

 **Warning**

This option is deprecated and will be removed in a future version of BIND.

**Grammar:** `coresize ( default | unlimited | <sizeval> ); // deprecated`

**Blocks:** options

**Tags:** deprecated

Sets the maximum size of a core dump.

This sets the maximum size of a core dump. The default is `default`.

**datasize**

 **Warning**

This option is deprecated and will be removed in a future version of BIND.

**Grammar:** `datasize ( default | unlimited | <sizeval> ); // deprecated`

**Blocks:** options

**Tags:** deprecated

Sets the maximum amount of data memory that can be used by the server.

This sets the maximum amount of data memory the server may use. The default is `default`. This is a hard limit on server memory usage; if the server attempts to allocate memory in excess of this limit, the allocation will fail, which may in turn leave the server unable to perform DNS service. Therefore, this option is rarely useful as a way to limit the amount of memory used by the server, but it can be used to raise an operating system data size limit that is too small by default. To limit the amount of memory used by the server, use the `max-cache-size` and `recursive-clients` options instead.

**files**

 **Warning**

This option is deprecated and will be removed in a future version of BIND.

**Grammar:** `files ( default | unlimited | <sizeval> ); // deprecated`

**Blocks:** options

**Tags:** deprecated

Sets the maximum number of files the server may have open concurrently.

This sets the maximum number of files the server may have open concurrently. The default is `unlimited`.

**stacksize****Warning**

This option is deprecated and will be removed in a future version of BIND.

**Grammar:** `stacksize ( default | unlimited | <sizeval> ); // deprecated`

**Blocks:** options

**Tags:** deprecated

Sets the maximum amount of stack memory that can be used by the server.

This sets the maximum amount of stack memory the server may use. The default is `default`.

**Server Resource Limits**

The following options set limits on the server's resource consumption that are enforced internally by the server rather than by the operating system.

**max-journal-size**

**Grammar:** `max-journal-size ( default | unlimited | <sizeval> );`

**Blocks:** options, view, zone (mirror, primary, secondary)

**Tags:** transfer

Controls the size of journal files.

This sets a maximum size for each journal file (see *The Journal File*), expressed in bytes or, if followed by an optional unit suffix ('k', 'm', or 'g'), in kilobytes, megabytes, or gigabytes. When the journal file approaches the specified size, some of the oldest transactions in the journal are automatically removed. The largest permitted value is 2 gigabytes. Very small values are rounded up to 4096 bytes. It is possible to specify `unlimited`, which also means 2 gigabytes. If the limit is set to `default` or left unset, the journal is allowed to grow up to twice as large as the zone. (There is little benefit in storing larger journals.)

This option may also be set on a per-zone basis.

**max-records**

**Grammar:** `max-records <integer>;`

**Blocks:** options, view, zone (mirror, primary, redirect, secondary, static-stub, stub)

**Tags:** zone, server

Sets the maximum number of records permitted in a zone.

This sets the maximum number of records permitted in a zone. The default is zero, which means the maximum is unlimited.

**max-records-per-type**

**Grammar:** `max-records-per-type <integer>;`

**Blocks:** options, view, zone (mirror, primary, redirect, secondary, static-stub, stub)

**Tags:** server

Sets the maximum number of records that can be stored in an RRset.

This sets the maximum number of resource records that can be stored in an RRset in a database. When configured in *options* or *view*, it controls the cache database; it also sets the default value for zone databases, which can be overridden by setting it at the *zone* level.

If set to a positive value, any attempt to cache, or to add to a zone an RRset with more than the specified number of records, will result in a failure. If set to 0, there is no cap on RRset size. The default is 100.

**max-types-per-name**

**Grammar:** max-types-per-name <integer>;

**Blocks:** options, view, zone (mirror, primary, redirect, secondary, static-stub, stub)

**Tags:** server

Sets the maximum number of RR types that can be stored for an owner name.

This sets the maximum number of resource record types that can be stored for a single owner name in a database. When configured in *options* or *view*, it controls the cache database and sets the default value for zone databases, which can be overridden by setting it at the *zone* level.

An RR type and its corresponding signature are counted as two types. So, for example, a signed node containing A and AAAA records has four types: A, RRSIG(A), AAAA, and RRSIG(AAAA).

The behavior is slightly different for zone and cache databases:

In a zone, if *max-types-per-name* is set to a positive number, any attempt to add a new resource record set to a name that already has the specified number of types will fail.

In a cache, if *max-types-per-name* is set to a positive number, an attempt to add a new resource record set to a name that already has the specified number of types will temporarily succeed, so that the query can be answered. However, the newly added RRset will immediately be purged.

Certain high-priority types, including SOA, CNAME, DNSKEY, and their corresponding signatures, are always cached. If *max-types-per-name* is set to a very low value, then it may be ignored to allow high-priority types to be cached.

When *max-types-per-name* is set to 0, there is no cap on the number of RR types. The default is 100.

**recursive-clients**

**Grammar:** recursive-clients <integer>;

**Blocks:** options

**Tags:** query

Specifies the maximum number of concurrent recursive queries the server can perform.

This sets the maximum number (a "hard quota") of simultaneous recursive lookups the server performs on behalf of clients. The default is 1000. Because each recursing client uses a fair bit of memory (on the order of 20 kilobytes), the value of the *recursive-clients* option may have to be decreased on hosts with limited memory.

*recursive-clients* defines a "hard quota" limit for pending recursive clients; when more clients than this are pending, new incoming requests are not accepted, and for each incoming request a previous pending request is dropped.

A "soft quota" is also set. When this lower quota is exceeded, incoming requests are accepted, but for each one, a pending request is dropped. If *recursive-clients* is greater than 1000, the soft quota is set to *recursive-clients* minus 100; otherwise it is set to 90% of *recursive-clients*.

**tcp-clients**

**Grammar:** `tcp-clients <integer>;`

**Blocks:** options

**Tags:** server

Specifies the maximum number of simultaneous client TCP connections accepted by the server.

This is the maximum number of simultaneous client TCP connections that the server accepts. The default is 150.

**clients-per-query**

**Grammar:** `clients-per-query <integer>;`

**Blocks:** options, view

**Tags:** server

Sets the initial minimum number of simultaneous recursive clients accepted by the server for any given query before the server drops additional clients.

This sets the initial value (minimum) number of simultaneous recursive clients for any given query (<qname,qtype,qclass>) that the server accepts before dropping additional clients. *named* attempts to self-tune this value and changes are logged. The default value is 10.

The chosen value should reflect how many queries come in for a given name in the time it takes to resolve that name.

**max-clients-per-query**

**Grammar:** `max-clients-per-query <integer>;`

**Blocks:** options, view

**Tags:** server

Sets the maximum number of simultaneous recursive clients accepted by the server for any given query before the server drops additional clients.

This sets the maximum number of simultaneous recursive clients for any given query (<qname,qtype,qclass>) that the server accepts before dropping additional clients.

If the number of queries exceeds *clients-per-query*, *named* assumes that it is dealing with a non-responsive zone and drops additional queries. If it gets a response after dropping queries, it raises the estimate, up to a limit of *max-clients-per-query*. The estimate is then lowered after 20 minutes if it has remained unchanged.

If *max-clients-per-query* is set to zero, there is no upper bound, other than that imposed by *recursive-clients*. If *clients-per-query* is set to zero, *max-clients-per-query* no longer applies and there is no upper bound, other than that imposed by *recursive-clients*.

**fetches-per-zone**

**Grammar:** `fetches-per-zone <integer> [ ( drop | fail ) ];`

**Blocks:** options, view

**Tags:** server, query

Sets the maximum number of simultaneous iterative queries allowed to any one domain before the server blocks new queries for data in or beneath that zone.

This sets the maximum number of simultaneous iterative queries to any one domain that the server permits before blocking new queries for data in or beneath that zone. This value should reflect how many fetches would normally be sent to any one zone in the time it would take to resolve them. It should be smaller than *recursive-clients*.

When many clients simultaneously query for the same name and type, the clients are all attached to the same fetch, up to the *max-clients-per-query* limit, and only one iterative query is sent. However, when clients are simultaneously querying for *different* names or types, multiple queries are sent and *max-clients-per-query* is not effective as a limit.

Optionally, this value may be followed by the keyword *drop* or *fail*, indicating whether queries which exceed the fetch quota for a zone are dropped with no response, or answered with SERVFAIL. The default is *drop*.

If *fetches-per-zone* is set to zero, there is no limit on the number of fetches per query and no queries are dropped. The default is zero.

The current list of active fetches can be dumped by running *rndc recursing*. The list includes the number of active fetches for each domain and the number of queries that have been passed (allowed) or dropped (spilled) as a result of the *fetches-per-zone* limit. (Note: these counters are not cumulative over time; whenever the number of active fetches for a domain drops to zero, the counter for that domain is deleted, and the next time a fetch is sent to that domain, it is recreated with the counters set to zero.)

**fetches-per-server**

**Grammar:** `fetches-per-server <integer> [ ( drop | fail ) ] ;`

**Blocks:** options, view

**Tags:** server, query

Sets the maximum number of simultaneous iterative queries allowed to be sent by a server to an upstream name server before the server blocks additional queries.

This sets the maximum number of simultaneous iterative queries that the server allows to be sent to a single upstream name server before blocking additional queries. This value should reflect how many fetches would normally be sent to any one server in the time it would take to resolve them. It should be smaller than *recursive-clients*.

Optionally, this value may be followed by the keyword *drop* or *fail*, indicating whether queries are dropped with no response or answered with SERVFAIL, when all of the servers authoritative for a zone are found to have exceeded the per-server quota. The default is *fail*.

If *fetches-per-server* is set to zero, there is no limit on the number of fetches per query and no queries are dropped. The default is zero.

The *fetches-per-server* quota is dynamically adjusted in response to detected congestion. As queries are sent to a server and either are answered or time out, an exponentially weighted moving average is calculated of the ratio of timeouts to responses. If the current average timeout ratio rises above a "high" threshold, then *fetches-per-server* is reduced for that server. If the timeout ratio drops below a "low" threshold, then *fetches-per-server* is increased. The *fetch-quota-params* options can be used to adjust the parameters for this calculation.

**fetch-quota-params**

**Grammar:** `fetch-quota-params <integer> <fixedpoint> <fixedpoint> <fixedpoint> ;`

**Blocks:** options, view

**Tags:** server, query

Sets the parameters for dynamic resizing of the *fetches-per-server* quota in response to detected congestion.

This sets the parameters to use for dynamic resizing of the *fetches-per-server* quota in response to detected congestion.

The first argument is an integer value indicating how frequently to recalculate the moving average of the ratio of timeouts to responses for each server. The default is 100, meaning that BIND recalculates the average ratio after every 100 queries have either been answered or timed out.

The remaining three arguments represent the "low" threshold (defaulting to a timeout ratio of 0.1), the "high" threshold (defaulting to a timeout ratio of 0.3), and the discount rate for the moving average (defaulting to 0.7). A higher discount rate causes recent events to weigh more heavily when calculating the moving average; a lower discount rate causes past events to weigh more heavily, smoothing out short-term blips in the timeout ratio. These arguments are all fixed-point numbers with precision of 1/100; at most two places after the decimal point are significant.

**reserved-sockets**

 **Warning**

This option is deprecated and will be removed in a future version of BIND.

**Grammar:** `reserved-sockets <integer>; // deprecated`

**Blocks:** options

**Tags:** deprecated

Deprecated.

This option is deprecated and no longer has any effect.

**max-cache-size**

**Grammar:** `max-cache-size ( default | unlimited | <sizeval> | <percentage> );`

**Blocks:** options, view

**Tags:** server

Sets the maximum amount of memory to use for an individual cache database and its associated metadata.

This sets the maximum amount of memory to use for an individual cache database and its associated metadata, in bytes or percentage of total physical memory. By default, each view has its own separate cache, which means the total amount of memory required for cache data is the sum of the cache database sizes for all views (unless the *attach-cache* option is used).

When the amount of data in a cache database reaches the configured limit, *named* starts purging non-expired records (following an LRU-based strategy).

The default size limit for each individual cache is:

- 90% of physical memory for views with *recursion* set to *yes* (the default), or
- 2 MB for views with *recursion* set to *no*.

Any positive value smaller than 2 MB is ignored and reset to 2 MB. The keyword `unlimited`, or the value `0`, places no limit on the cache size; records are then purged from the cache only when they expire (according to their TTLs).

**Note**

For configurations which define multiple views with separate caches and recursion enabled, it is recommended to set `max-cache-size` appropriately for each view, as using the default value of that option (90% of physical memory for each individual cache) may lead to memory exhaustion over time.

**Note**

`max-cache-size` does not work reliably for a maximum amount of memory of 100 MB or lower.

Upon startup and reconfiguration, caches with a limited size preallocate a small amount of memory (less than 1% of `max-cache-size` for a given view). This preallocation serves as an optimization to eliminate extra latency introduced by resizing internal cache structures.

On systems where detection of the amount of physical memory is not supported, percentage-based values fall back to `unlimited`. Note that the amount of physical memory available is only detected on startup, so `named` does not adjust the cache size limits if the amount of physical memory is changed at runtime.

**tcp-listen-queue**

**Grammar:** `tcp-listen-queue <integer>;`

**Blocks:** options

**Tags:** server

Sets the listen-queue depth.

This sets the listen-queue depth. The default and minimum is 10. If the kernel supports the accept filter "dataready", this also controls how many TCP connections are queued in kernel space waiting for some data before being passed to accept. Non-zero values less than 10 are silently raised. A value of 0 may also be used; on most platforms this sets the listen-queue length to a system-defined default value.

**tcp-initial-timeout**

**Grammar:** `tcp-initial-timeout <integer>;`

**Blocks:** options

**Tags:** server, query

Sets the amount of time (in milliseconds) that the server waits on a new TCP connection for the first message from the client.

This sets the amount of time (in units of 100 milliseconds) that the server waits on a new TCP connection for the first message from the client. The default is 300 (30 seconds), the minimum is 25 (2.5 seconds), and the maximum is 1200 (two minutes). Values above the maximum or below the minimum are adjusted with a logged warning. (Note: this value must be greater than the expected round-trip delay time; otherwise, no client will ever have enough time to submit a message.) This value can be updated at runtime by using `rndc tcp-timeouts`.

**tcp-idle-timeout****Grammar:** `tcp-idle-timeout <integer>;`**Blocks:** options**Tags:** query

Sets the amount of time (in milliseconds) that the server waits on an idle TCP connection before closing it, if the EDNS TCP keepalive option is not in use.

This sets the amount of time (in units of 100 milliseconds) that the server waits on an idle TCP connection before closing it, when the client is not using the EDNS TCP keepalive option. The default is 300 (30 seconds), the maximum is 1200 (two minutes), and the minimum is 1 (one-tenth of a second). Values above the maximum or below the minimum are adjusted with a logged warning. See *tcp-keepalive-timeout* for clients using the EDNS TCP keepalive option. This value can be updated at runtime by using *rndc tcp-timeouts*.

**tcp-keepalive-timeout****Grammar:** `tcp-keepalive-timeout <integer>;`**Blocks:** options**Tags:** query

Sets the amount of time (in milliseconds) that the server waits on an idle TCP connection before closing it, if the EDNS TCP keepalive option is in use.

This sets the amount of time (in units of 100 milliseconds) that the server waits on an idle TCP connection before closing it, when the client is using the EDNS TCP keepalive option. The default is 300 (30 seconds), the maximum is 65535 (about 1.8 hours), and the minimum is 1 (one-tenth of a second). Values above the maximum or below the minimum are adjusted with a logged warning. This value may be greater than *tcp-idle-timeout* because clients using the EDNS TCP keepalive option are expected to use TCP connections for more than one message. This value can be updated at runtime by using *rndc tcp-timeouts*.

**tcp-advertised-timeout****Grammar:** `tcp-advertised-timeout <integer>;`**Blocks:** options**Tags:** query

Sets the timeout value (in milliseconds) that the server sends in responses containing the EDNS TCP keepalive option.

This sets the timeout value (in units of 100 milliseconds) that the server sends in responses containing the EDNS TCP keepalive option, which informs a client of the amount of time it may keep the session open. The default is 300 (30 seconds), the maximum is 65535 (about 1.8 hours), and the minimum is 0, which signals that the clients must close TCP connections immediately. Ordinarily this should be set to the same value as *tcp-keepalive-timeout*. This value can be updated at runtime by using *rndc tcp-timeouts*.

**update-quota****Grammar:** `update-quota <integer>;`**Blocks:** options**Tags:** server

Specifies the maximum number of concurrent DNS UPDATE messages that can be processed by the server.

This is the maximum number of simultaneous DNS UPDATE messages that the server will accept, for updating local authoritative zones or forwarding to a primary server. The default is 100.

## Periodic Task Intervals

### `heartbeat-interval`

 **Warning**

This option is deprecated and will be removed in a future version of BIND.

**Grammar:** `heartbeat-interval <integer>; // deprecated`

**Blocks:** options

**Tags:** deprecated

Sets the interval at which the server performs zone maintenance tasks for all zones marked as *dialup*.

The server performs zone maintenance tasks for all zones marked as *dialup* whenever this interval expires. The default is 60 minutes. Reasonable values are up to 1 day (1440 minutes). The maximum value is 28 days (40320 minutes). If set to 0, no zone maintenance for these zones occurs.

This option is deprecated and will be removed in a future release.

### `interface-interval`

**Grammar:** `interface-interval <duration>;`

**Blocks:** options

**Tags:** server

Sets the interval at which the server scans the network interface list.

The server scans the network interface list on every interval as specified by *interface-interval*.

If set to 0, interface scanning only occurs when the configuration file is loaded, or when *automatic-interface-scan* is enabled and supported by the operating system. After the scan, the server begins listening for queries on any newly discovered interfaces (provided they are allowed by the *listen-on* configuration), and stops listening on interfaces that have gone away. For convenience, TTL-style time-unit suffixes may be used to specify the value. It also accepts ISO 8601 duration formats.

The default is 60 minutes (1 hour); the maximum value is 28 days.

## The *sortlist* Statement

The response to a DNS query may consist of multiple resource records (RRs) forming a resource record set (RRset). The name server normally returns the RRs within the RRset in an indeterminate order (but see the *rrset-order* statement in *RRset Ordering*). The client resolver code should rearrange the RRs as appropriate: that is, using any addresses on the local net in preference to other addresses. However, not all resolvers can do this or are correctly configured. When a client is using a local server, the sorting can be performed in the server, based on the client's address. This only requires configuring the name servers, not all the clients.

**sortlist****Grammar:** `sortlist { <address_match_element>; ... };`**Blocks:** options, view**Tags:** query

Controls the ordering of RRs returned to the client, based on the client's IP address.

The `sortlist` statement (see below) takes an `address_match_list` and interprets it in a special way. Each top-level statement in the `sortlist` must itself be an explicit `address_match_list` with one or two elements. The first element (which may be an IP address, an IP prefix, an ACL name, or a nested `address_match_list`) of each top-level list is checked against the source address of the query until a match is found. When the addresses in the first element overlap, the first rule to match is selected.

Once the source address of the query has been matched, if the top-level statement contains only one element, the actual primitive element that matched the source address is used to select the address in the response to move to the beginning of the response. If the statement is a list of two elements, then the second element is interpreted as a topology preference list. Each top-level element is assigned a distance, and the address in the response with the minimum distance is moved to the beginning of the response.

In the following example, any queries received from any of the addresses of the host itself get responses preferring addresses on any of the locally connected networks. Next most preferred are addresses on the 192.168.1/24 network, and after that either the 192.168.2/24 or 192.168.3/24 network, with no preference shown between these two networks. Queries received from a host on the 192.168.1/24 network prefer other addresses on that network to the 192.168.2/24 and 192.168.3/24 networks. Queries received from a host on the 192.168.4/24 or the 192.168.5/24 network only prefer other addresses on their directly connected networks.

```
sortlist {
    // IF the local host
    // THEN first fit on the following nets
    { localhost;
      { localnets;
        192.168.1/24;
        { 192.168.2/24; 192.168.3/24; }; }; };
    // IF on class C 192.168.1 THEN use .1, or .2 or .3
    { 192.168.1/24;
      { 192.168.1/24;
        { 192.168.2/24; 192.168.3/24; }; }; };
    // IF on class C 192.168.2 THEN use .2, or .1 or .3
    { 192.168.2/24;
      { 192.168.2/24;
        { 192.168.1/24; 192.168.3/24; }; }; };
    // IF on class C 192.168.3 THEN use .3, or .1 or .2
    { 192.168.3/24;
      { 192.168.3/24;
        { 192.168.1/24; 192.168.2/24; }; }; };
    // IF .4 or .5 THEN prefer that net
    { { 192.168.4/24; 192.168.5/24; };
      };
};
```

The following example illustrates reasonable behavior for the local host and hosts on directly connected networks. Responses sent to queries from the local host favor any of the directly connected networks. Responses sent to queries from any other hosts on a directly connected network prefer addresses on that same network. Responses to other queries are

not sorted.

```
sortlist {
    { localhost; localnets; };
    { localnets; };
};
```

## RRset Ordering

### **Note**

While alternating the order of records in a DNS response between subsequent queries is a known load distribution technique, certain caveats apply (mostly stemming from caching) which usually make it a suboptimal choice for load balancing purposes when used on its own.

### **rrset-order**

**Grammar:** `rrset-order { [ class <string> ] [ type <string> ] [ name <quoted_string> ] <string> <string>; ... };`

**Blocks:** options, view

**Tags:** query

Defines the order in which equal RRs (RRsets) are returned.

The `rrset-order` statement permits configuration of the ordering of the records in a multiple-record response. See also: `sortlist`.

Each rule in an `rrset-order` statement is defined as follows:

```
[class <class_name>] [type <type_name>] [name "<domain_name>"] order <ordering>
```

The default qualifiers for each rule are:

- If no `class` is specified, the default is `ANY`.
- If no `type` is specified, the default is `ANY`.
- If no `name` is specified, the default is `*` (asterisk).

`<domain_name>` only matches the name itself, not any of its subdomains. To make a rule match all subdomains of a given name, a wildcard name (`*.<domain_name>`) must be used. Note that `*.<domain_name>` does *not* match `<domain_name>` itself; to specify RRset ordering for a name and all of its subdomains, two separate rules must be defined: one for `<domain_name>` and one for `*.<domain_name>`.

The legal values for `<ordering>` are:

#### **fixed**

Records are returned in the order they are defined in the zone file.

**Note**

The `fixed` option is only available if BIND is configured with `--enable-fixed-rrset` at compile time.

**random**

Records are returned in a non-deterministic order. The random ordering doesn't guarantee uniform distribution of all permutations.

**cyclic**

Records are returned in a cyclic round-robin order, rotating by one record per query.

**none**

Records are returned in the order they were retrieved from the database. This order is indeterminate, but remains consistent as long as the database is not modified.

The default RRset order used depends on whether any `rrset-order` statements are present in the configuration file used by `named`:

- If no `rrset-order` statement is present in the configuration file, the implicit default is to return all records in `random` order.
- If any `rrset-order` statements are present in the configuration file, but no ordering rule specified in these statements matches a given RRset, the default order for that RRset is `none`.

Note that if multiple `rrset-order` statements are present in the configuration file (at both the `options` and `view` levels), they are *not* combined; instead, the more-specific one (`view`) replaces the less-specific one (`options`).

If multiple rules within a single `rrset-order` statement match a given RRset, the first matching rule is applied.

Example:

```
rrset-order {
    type A name "foo.isc.org" order random;
    type AAAA name "foo.isc.org" order cyclic;
    name "bar.isc.org" order fixed;
    name "*.bar.isc.org" order random;
    name "*.baz.isc.org" order cyclic;
};
```

With the above configuration, the following RRset ordering is used:

QNAME	QTYPE	RRset Order
foo.isc.org	A	random
foo.isc.org	AAAA	cyclic
foo.isc.org	TXT	none
sub.foo.isc.org	all	none
bar.isc.org	all	fixed
sub.bar.isc.org	all	random
baz.isc.org	all	none
sub.baz.isc.org	all	cyclic

## Tuning

### `lame-ttl`

**Grammar:** `lame-ttl <duration>;`

**Blocks:** options, view

**Tags:** server

Sets the resolver's lame cache.

This is always set to 0. More information is available in the [security advisory for CVE-2021-25219](#).

### `servfail-ttl`

**Grammar:** `servfail-ttl <duration>;`

**Blocks:** options, view

**Tags:** server

Sets the length of time (in seconds) that a SERVFAIL response is cached.

This sets the number of seconds to cache a SERVFAIL response due to DNSSEC validation failure or other general server failure. If set to 0, SERVFAIL caching is disabled. The SERVFAIL cache is not consulted if a query has the CD (Checking Disabled) bit set; this allows a query that failed due to DNSSEC validation to be retried without waiting for the SERVFAIL TTL to expire.

The maximum value is 30 seconds; any higher value is silently reduced. The default is 1 second.

### `min-ncache-ttl`

**Grammar:** `min-ncache-ttl <duration>;`

**Blocks:** options, view

**Tags:** server

Specifies the minimum retention time (in seconds) for storage of negative answers in the server's cache.

To reduce network traffic and increase performance, the server stores negative answers. `min-ncache-ttl` is used to set a minimum retention time for these answers in the server, in seconds. For convenience, TTL-style time-unit suffixes may be used to specify the value. It also accepts ISO 8601 duration formats.

The default `min-ncache-ttl` is 0 seconds. `min-ncache-ttl` cannot exceed 90 seconds and is truncated to 90 seconds if set to a greater value.

### `min-cache-ttl`

**Grammar:** `min-cache-ttl <duration>;`

**Blocks:** options, view

**Tags:** server

Specifies the minimum time (in seconds) that the server caches ordinary (positive) answers.

This sets the minimum time for which the server caches ordinary (positive) answers, in seconds. For convenience, TTL-style time-unit suffixes may be used to specify the value. It also accepts ISO 8601 duration formats.

The default `min-cache-ttl` is 0 seconds. `min-cache-ttl` cannot exceed 90 seconds and is truncated to 90 seconds if set to a greater value.

**max-ncache-ttl****Grammar:** `max-ncache-ttl <duration>;`**Blocks:** options, view**Tags:** server

Specifies the maximum retention time (in seconds) for storage of negative answers in the server's cache.

To reduce network traffic and increase performance, the server stores negative answers. `max-ncache-ttl` is used to set a maximum retention time for these answers in the server, in seconds. For convenience, TTL-style time-unit suffixes may be used to specify the value. It also accepts ISO 8601 duration formats.

The default `max-ncache-ttl` is 10800 seconds (3 hours). `max-ncache-ttl` cannot exceed 7 days and is silently truncated to 7 days if set to a greater value.

**max-cache-ttl****Grammar:** `max-cache-ttl <duration>;`**Blocks:** options, view**Tags:** server

Specifies the maximum time (in seconds) that the server caches ordinary (positive) answers.

This sets the maximum time for which the server caches ordinary (positive) answers, in seconds. For convenience, TTL-style time-unit suffixes may be used to specify the value. It also accepts ISO 8601 duration formats.

The default `max-cache-ttl` is 604800 (one week). A value of zero may cause all queries to return SERVFAIL, because of lost caches of intermediate RRsets (such as NS and glue AAAA/A records) in the resolution process.

**max-stale-ttl****Grammar:** `max-stale-ttl <duration>;`**Blocks:** options, view**Tags:** server

Specifies the maximum time that the server retains records past their normal expiry, to return them as stale records.

If retaining stale RRsets in cache is enabled, and returning of stale cached answers is also enabled, `max-stale-ttl` sets the maximum time for which the server retains records past their normal expiry to return them as stale records, when the servers for those records are not reachable. The default is 1 day. The minimum allowed is 1 second; a value of 0 is updated silently to 1 second.

For stale answers to be returned, the retaining of them in cache must be enabled via the configuration option `stale-cache-enable`, and returning cached answers must be enabled, either in the configuration file using the `stale-answer-enable` option or by calling `rndc serve-stale on`.

When `stale-cache-enable` is set to `no`, setting the `max-stale-ttl` has no effect; the value of `max-stale-ttl` will be 0 in such case.

**resolver-nonbackoff-tries**

 **Warning**

This option is deprecated and will be removed in a future version of BIND.

**Grammar:** `resolver-nonbackoff-tries <integer>; // deprecated`

**Blocks:** options, view

**Tags:** deprecated.

Specifies the number of retries before exponential backoff.

This specifies how many retries occur before exponential backoff kicks in. The default is 3.

This option is deprecated and will be removed in a future release.

**resolver-retry-interval**

 **Warning**

This option is deprecated and will be removed in a future version of BIND.

**Grammar:** `resolver-retry-interval <integer>; // deprecated`

**Blocks:** options, view

**Tags:** deprecated

Sets the base retry interval (in milliseconds).

This sets the base retry interval in milliseconds. The default is 800.

This option is deprecated and will be removed in a future release.

**sig-validity-interval**

**Grammar:** `sig-validity-interval <integer> [ <integer> ];`

**Blocks:** options, view, zone (primary, secondary)

**Tags:** dnssec

Specifies the maximum number of days that RRSIGs generated by *named* are valid.

This specifies the upper bound of the number of days that RRSIGs generated by *named* are valid; the default is 30 days, with a maximum of 3660 days (10 years). The optional second value specifies the minimum bound on those RRSIGs and also determines how long before expiry *named* starts regenerating those RRSIGs. The default value for the lower bound is 1/4 of the upper bound; it is expressed in days if the upper bound is greater than 7, and hours if it is less than or equal to 7 days.

When new RRSIGs are generated, the length of time is randomly chosen between these two limits, to spread out the re-signing load. When RRSIGs are re-generated, the upper bound is used, with a small amount of jitter added. New RRSIGs are generated by a number of processes, including the processing of UPDATE requests (ref:*dynamic\_update*), the addition and removal of records via in-line signing, and the initial signing of a zone.

The signature inception time is unconditionally set to one hour before the current time, to allow for a limited amount of clock skew.

The *sig-validity-interval* can be overridden for DNSKEY records by setting *dnskey-sig-validity*.

The *sig-validity-interval* should be at least several multiples of the SOA expire interval, to allow for reasonable interaction between the various timer and expiry dates.

**dnskey-sig-validity**

**Grammar:** `dnskey-sig-validity <integer>;`

**Blocks:** options, view, zone (primary, secondary)

**Tags:** dnssec

Specifies the number of days in the future when automatically generated DNSSEC signatures expire.

This specifies the number of days into the future when DNSSEC signatures that are automatically generated for DNSKEY RRsets as a result of dynamic updates (*Dynamic Update*) will expire. If set to a non-zero value, this overrides the value set by *sig-validity-interval*. The default is zero, meaning *sig-validity-interval* is used. The maximum value is 3660 days (10 years), and higher values are rejected.

**sig-signing-nodes**

**Grammar:** `sig-signing-nodes <integer>;`

**Blocks:** options, view, zone (primary, secondary)

**Tags:** dnssec

Specifies the maximum number of nodes to be examined in each quantum, when signing a zone with a new DNSKEY.

This specifies the maximum number of nodes to be examined in each quantum, when signing a zone with a new DNSKEY. The default is 100.

**sig-signing-signatures**

**Grammar:** `sig-signing-signatures <integer>;`

**Blocks:** options, view, zone (primary, secondary)

**Tags:** dnssec

Specifies the threshold for the number of signatures that terminates processing a quantum, when signing a zone with a new DNSKEY.

This specifies a threshold number of signatures that terminates processing a quantum, when signing a zone with a new DNSKEY. The default is 10.

**sig-signing-type**

**Grammar:** `sig-signing-type <integer>;`

**Blocks:** options, view, zone (primary, secondary)

**Tags:** dnssec

Specifies a private RDATA type to use when generating signing-state records.

This specifies a private RDATA type to be used when generating signing-state records. The default is 65534.

This parameter may be removed in a future version, once there is a standard type.

Signing-state records are used internally by *named* to track the current state of a zone-signing process, i.e., whether it is still active or has been completed. The records can be inspected using the command `rndc signing -list zone`. Once *named* has finished signing a zone with a particular key, the signing-state record associated with that key can be removed from the zone by running `rndc signing -clear keyid/algorithm zone`. To clear all of the completed signing-state records for a zone, use `rndc signing -clear all zone`.

**min-refresh-time**

**Grammar:** min-refresh-time <integer>;

**Blocks:** options, view, zone (mirror, secondary, stub)

**Tags:** transfer

Limits the zone refresh interval to no more often than the specified value, in seconds.

This option controls the server's behavior on refreshing a zone (querying for SOA changes). Usually, the SOA refresh values for the zone are used; however, these values are set by the primary, giving secondary server administrators little control over their contents.

This option allows the administrator to set a minimum refresh time in seconds per-zone, per-view, or globally. This option is valid for secondary and stub zones, and clamps the SOA refresh time to the specified value.

The default is 300 seconds.

**max-refresh-time**

**Grammar:** max-refresh-time <integer>;

**Blocks:** options, view, zone (mirror, secondary, stub)

**Tags:** transfer

Limits the zone refresh interval to no less often than the specified value, in seconds.

This option controls the server's behavior on refreshing a zone (querying for SOA changes). Usually, the SOA refresh values for the zone are used; however, these values are set by the primary, giving secondary server administrators little control over their contents.

This option allows the administrator to set a maximum refresh time in seconds per-zone, per-view, or globally. This option is valid for secondary and stub zones, and clamps the SOA refresh time to the specified value.

The default is 2419200 seconds (4 weeks).

**min-retry-time**

**Grammar:** min-retry-time <integer>;

**Blocks:** options, view, zone (mirror, secondary, stub)

**Tags:** transfer

Limits the zone refresh retry interval to no more often than the specified value, in seconds.

This option controls the server's behavior on retrying failed zone transfers. Usually, the SOA retry values for the zone are used; however, these values are set by the primary, giving secondary server administrators little control over their contents.

This option allows the administrator to set a minimum retry time in seconds per-zone, per-view, or globally. This option is valid for secondary and stub zones, and clamps the SOA retry time to the specified value.

The default is 500 seconds.

**max-retry-time****Grammar:** `max-retry-time <integer>;`**Blocks:** options, view, zone (mirror, secondary, stub)**Tags:** transfer

Limits the zone refresh retry interval to no less often than the specified value, in seconds.

This option controls the server's behavior on retrying failed zone transfers. Usually, the SOA retry values for the zone are used; however, these values are set by the primary, giving secondary server administrators little control over their contents.

This option allows the administrator to set a maximum retry time in seconds per-zone, per-view, or globally. This option is valid for secondary and stub zones, and clamps the SOA retry time to the specified value.

The default is 1209600 seconds (2 weeks).

**edns-udp-size****Grammar:** `edns-udp-size <integer>;`**Blocks:** options, server, view, view.server**Tags:** query

Sets the maximum advertised EDNS UDP buffer size to control the size of packets received from authoritative servers in response to recursive queries.

This sets the maximum advertised EDNS UDP buffer size, in bytes, to control the size of packets received from authoritative servers in response to recursive queries. Valid values are 512 to 4096; values outside this range are silently adjusted to the nearest value within it. The default value is 1232.

The usual reason for setting `edns-udp-size` to a non-default value is to get UDP answers to pass through broken firewalls that block fragmented packets and/or block UDP DNS packets that are greater than 512 bytes.

When `named` first queries a remote server, it advertises a UDP buffer size of 1232.

Query timeouts observed for any given server affect the buffer size advertised in queries sent to that server. Depending on observed packet dropping patterns, the query is retried over TCP. Per-server EDNS statistics are only retained in memory for the lifetime of a given server's ADB entry.

According to measurements taken by multiple parties, the default value should not be causing the fragmentation. As most of the Internet "core" is able to cope with IP message sizes between 1400-1500 bytes, the 1232 size was chosen as a conservative minimal number that could be changed by the DNS operator to a estimated path MTU, minus the estimated header space. In practice, the smallest MTU witnessed in the operational DNS community is 1500 octets, the Ethernet maximum payload size, so a useful default for the maximum DNS/UDP payload size on **reliable** networks would be 1432.

Any server-specific `edns-udp-size` setting has precedence over all the above rules, i.e. configures a static value for a given `server` block.

**max-udp-size****Grammar:** `max-udp-size <integer>;`**Blocks:** options, server, view, view.server**Tags:** query

Sets the maximum EDNS UDP message size sent by `named`.

This sets the maximum EDNS UDP message size that *named* sends, in bytes. Valid values are 512 to 4096; values outside this range are silently adjusted to the nearest value within it. The default value is 1232.

This value applies to responses sent by a server; to set the advertised buffer size in queries, see *edns-udp-size*.

The usual reason for setting *max-udp-size* to a non-default value is to allow UDP answers to pass through broken firewalls that block fragmented packets and/or block UDP packets that are greater than 512 bytes. This is independent of the advertised receive buffer (*edns-udp-size*).

Setting this to a low value encourages additional TCP traffic to the name server.

#### **masterfile-format**

**Grammar:** `masterfile-format ( raw | text );`

**Blocks:** options, view, zone (mirror, primary, redirect, secondary, stub)

**Tags:** zone, server

Specifies the file format of zone files.

This specifies the file format of zone files (see *Additional File Formats* for details). The default value is *text*, which is the standard textual representation, except for secondary zones, in which the default value is *raw*. Files in formats other than *text* are typically expected to be generated by the *named-compilezone* tool, or dumped by *named*.

Note that when a zone file in a format other than *text* is loaded, *named* may omit some of the checks which are performed for a file in *text* format. For example, *check-names* only applies when loading zones in *text* format. Zone files in *raw* format should be generated with the same check level as that specified in the *named* configuration file.

When configured in *options*, this statement sets the *masterfile-format* for all zones, but it can be overridden on a per-zone or per-view basis by including a *masterfile-format* statement within the *zone* or *view* block in the configuration file.

#### **masterfile-style**

**Grammar:** `masterfile-style ( full | relative );`

**Blocks:** options, view, zone (mirror, primary, redirect, secondary, stub)

**Tags:** server

Specifies the format of zone files during a dump, when the *masterfile-format* is *text*.

This specifies the formatting of zone files during dump, when the *masterfile-format* is *text*. This option is ignored with any other *masterfile-format*.

When set to *relative*, records are printed in a multi-line format, with owner names expressed relative to a shared origin. When set to *full*, records are printed in a single-line format with absolute owner names. The *full* format is most suitable when a zone file needs to be processed automatically by a script. The *relative* format is more human-readable, and is thus suitable when a zone is to be edited by hand. The default is *relative*.

#### **max-query-count**

**Grammar:** `max-query-count <integer>;`

**Blocks:** options, view

**Tags:** server, query

Sets the maximum number of iterative queries while servicing a recursive query.

This sets the maximum number of iterative queries that may be sent by a resolver while looking up a single name. If more queries than this need to be sent before an answer is reached, then recursion is terminated and a SERVFAIL response is returned to the client. The default is 200.

**max-recursion-depth**

**Grammar:** `max-recursion-depth <integer>;`

**Blocks:** options, view

**Tags:** server

Sets the maximum number of levels of recursion permitted at any one time while servicing a recursive query.

This sets the maximum number of levels of recursion that are permitted at any one time while servicing a recursive query. Resolving a name may require looking up a name server address, which in turn requires resolving another name, etc.; if the number of recursions exceeds this value, the recursive query is terminated and returns SERVFAIL. The default is 7.

**max-recursion-queries**

**Grammar:** `max-recursion-queries <integer>;`

**Blocks:** options, view

**Tags:** server, query

Sets the maximum number of iterative queries while servicing a recursive query.

This sets the maximum number of iterative queries that may be sent by a resolver while looking up a single name. If more queries than this need to be sent before an answer is reached, then recursion is terminated and a SERVFAIL response is returned to the client. (Note: if the answer is a CNAME, then the subsequent lookup for the target of the CNAME is counted separately.) The default is 50.

**max-query-restarts**

**Grammar:** `max-query-restarts <integer>;`

**Blocks:** options, view

**Tags:** server, query

Sets the maximum number of chained CNAMEs to follow

This sets the maximum number of successive CNAME targets to follow when resolving a client query, before terminating the query to avoid a CNAME loop. Valid values are 1 to 255. The default is 11.

**notify-delay**

**Grammar:** `notify-delay <integer>;`

**Blocks:** options, view, zone (mirror, primary, secondary)

**Tags:** transfer, zone

Sets the delay (in seconds) between sending sets of NOTIFY messages for a zone.

This sets the delay, in seconds, between sending sets of NOTIFY messages for a zone. Whenever a NOTIFY message is sent for a zone, a timer will be set for this duration. If the zone is updated again before the timer expires, the NOTIFY for that update will be postponed. The default is 5 seconds.

The overall rate at which NOTIFY messages are sent for all zones is controlled by *notify-rate*.

**max-rsa-exponent-size**

**Grammar:** max-rsa-exponent-size <integer>;

**Blocks:** options

**Tags:** dnssec, query

Sets the maximum RSA exponent size (in bits) when validating.

This sets the maximum RSA exponent size, in bits, that is accepted when validating. Valid values are 35 to 4096 bits. The default, zero, is also accepted and is equivalent to 4096.

**prefetch**

**Grammar:** prefetch <integer> [ <integer> ];

**Blocks:** options, view

**Tags:** query

Specifies the "trigger" time-to-live (TTL) value at which prefetch of the current query takes place.

When a query is received for cached data which is to expire shortly, *named* can refresh the data from the authoritative server immediately, ensuring that the cache always has an answer available.

*prefetch* specifies the "trigger" TTL value at which prefetch of the current query takes place; when a cache record with an equal or lower TTL value is encountered during query processing, it is refreshed. Valid trigger TTL values are 1 to 10 seconds. Values larger than 10 seconds are silently reduced to 10. Setting a trigger TTL to zero causes prefetch to be disabled. The default trigger TTL is 2.

An optional second argument specifies the "eligibility" TTL: the smallest *original* TTL value that is accepted for a record to be eligible for prefetching. The eligibility TTL must be at least six seconds longer than the trigger TTL; if not, *named* silently adjusts it upward. The default eligibility TTL is 9.

**v6-bias**

**Grammar:** v6-bias <integer>;

**Blocks:** options, view

**Tags:** server, query

Indicates the number of milliseconds of preference to give to IPv6 name servers.

When determining the next name server to try, this indicates by how many milliseconds to prefer IPv6 name servers. The default is 50 milliseconds.

**tcp-receive-buffer**

**Grammar:** tcp-receive-buffer <integer>;

**Blocks:** options

**Tags:** server

Sets the operating system's receive buffer size for TCP sockets.

**udp-receive-buffer****Grammar:** `udp-receive-buffer <integer>;`**Blocks:** options**Tags:** server

Sets the operating system's receive buffer size for UDP sockets.

These options control the operating system's receive buffer sizes (`SO_RCVBUF`) for TCP and UDP sockets, respectively. Buffering at the operating system level can prevent packet drops during brief load spikes, but if the buffer size is set too high, a running server could get clogged with outstanding queries that have already timed out. The default is 0, which means the operating system's default value should be used. The minimum configurable value is 4096; any nonzero value lower than that is silently raised. The maximum value is determined by the kernel, and values exceeding the maximum are silently reduced.

**tcp-send-buffer****Grammar:** `tcp-send-buffer <integer>;`**Blocks:** options**Tags:** server

Sets the operating system's send buffer size for TCP sockets.

**udp-send-buffer****Grammar:** `udp-send-buffer <integer>;`**Blocks:** options**Tags:** server

Sets the operating system's send buffer size for UDP sockets.

These options control the operating system's send buffer sizes (`SO_SNDBUF`) for TCP and UDP sockets, respectively. Buffering at the operating system level can prevent packet drops during brief load spikes, but if the buffer size is set too high, a running server could get clogged with outstanding queries that have already timed out. The default is 0, which means the operating system's default value should be used. The minimum configurable value is 4096; any nonzero value lower than that is silently raised. The maximum value is determined by the kernel, and values exceeding the maximum are silently reduced.

**Built-in Server Information Zones**

The server provides some helpful diagnostic information through a number of built-in zones under the pseudo-top-level-domain `bind` in the `CHAOS` class. These zones are part of a built-in view (see *view*) of class `CHAOS`, which is separate from the default view of class `IN`. Most global configuration options (*allow-query*, etc.) apply to this view, but some are locally overridden: *notify*, *recursion*, and *allow-new-zones* are always set to `no`, and *rate-limit* is set to allow three responses per second.

To disable these zones, use the options below or hide the built-in `CHAOS` view by defining an explicit view of class `CHAOS` that matches all clients.

**version****Grammar:** `version ( <quoted_string> | none );`**Blocks:** options

**Tags:** server

Specifies the version number of the server to return in response to a `version.bind` query.

This is the version the server should report via a query of the name `version.bind` with type `TXT` and class `CHAOS`. The default is the real version number of this server. Specifying `version none` disables processing of the queries.

Setting `version` to any value (including `none`) also disables queries for `authors.bind` `TXT` `CH`.

#### **hostname**

**Grammar:** `hostname ( <quoted_string> | none );`

**Blocks:** options

**Tags:** server

Specifies the hostname of the server to return in response to a `hostname.bind` query.

This is the hostname the server should report via a query of the name `hostname.bind` with type `TXT` and class `CHAOS`. This defaults to the hostname of the machine hosting the name server, as found by the `gethostname()` function. The primary purpose of such queries is to identify which of a group of anycast servers is actually answering the queries. Specifying `hostname none;` disables processing of the queries.

#### **server-id**

**Grammar:** `server-id ( <quoted_string> | none | hostname );`

**Blocks:** options

**Tags:** server

Specifies the ID of the server to return in response to a `ID.SERVER` query.

This is the ID the server should report when receiving a Name Server Identifier (NSID) query, or a query of the name `ID.SERVER` with type `TXT` and class `CHAOS`. The primary purpose of such queries is to identify which of a group of anycast servers is actually answering the queries. Specifying `server-id none;` disables processing of the queries. Specifying `server-id hostname;` causes `named` to use the hostname as found by the `gethostname()` function. The default `server-id` is `none`.

## **Built-in Empty Zones**

The `named` server has some built-in empty zones, for SOA and NS records only. These are for zones that should normally be answered locally and for which queries should not be sent to the Internet's root servers. The official servers that cover these namespaces return `NXDOMAIN` responses to these queries. In particular, these cover the reverse namespaces for addresses from **RFC 1918**, **RFC 4193**, **RFC 5737**, and **RFC 6598**. They also include the reverse namespace for the IPv6 local address (locally assigned), IPv6 link local addresses, the IPv6 loopback address, and the IPv6 unknown address.

The server attempts to determine if a built-in zone already exists or is active (covered by a forward-only forwarding declaration) and does not create an empty zone if either is true.

The current list of empty zones is:

- 10.IN-ADDR.ARPA
- 16.172.IN-ADDR.ARPA
- 17.172.IN-ADDR.ARPA
- 18.172.IN-ADDR.ARPA

- 19.172.IN-ADDR.ARPA
- 20.172.IN-ADDR.ARPA
- 21.172.IN-ADDR.ARPA
- 22.172.IN-ADDR.ARPA
- 23.172.IN-ADDR.ARPA
- 24.172.IN-ADDR.ARPA
- 25.172.IN-ADDR.ARPA
- 26.172.IN-ADDR.ARPA
- 27.172.IN-ADDR.ARPA
- 28.172.IN-ADDR.ARPA
- 29.172.IN-ADDR.ARPA
- 30.172.IN-ADDR.ARPA
- 31.172.IN-ADDR.ARPA
- 168.192.IN-ADDR.ARPA
- 64.100.IN-ADDR.ARPA
- 65.100.IN-ADDR.ARPA
- 66.100.IN-ADDR.ARPA
- 67.100.IN-ADDR.ARPA
- 68.100.IN-ADDR.ARPA
- 69.100.IN-ADDR.ARPA
- 70.100.IN-ADDR.ARPA
- 71.100.IN-ADDR.ARPA
- 72.100.IN-ADDR.ARPA
- 73.100.IN-ADDR.ARPA
- 74.100.IN-ADDR.ARPA
- 75.100.IN-ADDR.ARPA
- 76.100.IN-ADDR.ARPA
- 77.100.IN-ADDR.ARPA
- 78.100.IN-ADDR.ARPA
- 79.100.IN-ADDR.ARPA
- 80.100.IN-ADDR.ARPA
- 81.100.IN-ADDR.ARPA
- 82.100.IN-ADDR.ARPA
- 83.100.IN-ADDR.ARPA
- 84.100.IN-ADDR.ARPA
- 85.100.IN-ADDR.ARPA

- 86.100.IN-ADDR.ARPA
- 87.100.IN-ADDR.ARPA
- 88.100.IN-ADDR.ARPA
- 89.100.IN-ADDR.ARPA
- 90.100.IN-ADDR.ARPA
- 91.100.IN-ADDR.ARPA
- 92.100.IN-ADDR.ARPA
- 93.100.IN-ADDR.ARPA
- 94.100.IN-ADDR.ARPA
- 95.100.IN-ADDR.ARPA
- 96.100.IN-ADDR.ARPA
- 97.100.IN-ADDR.ARPA
- 98.100.IN-ADDR.ARPA
- 99.100.IN-ADDR.ARPA
- 100.100.IN-ADDR.ARPA
- 101.100.IN-ADDR.ARPA
- 102.100.IN-ADDR.ARPA
- 103.100.IN-ADDR.ARPA
- 104.100.IN-ADDR.ARPA
- 105.100.IN-ADDR.ARPA
- 106.100.IN-ADDR.ARPA
- 107.100.IN-ADDR.ARPA
- 108.100.IN-ADDR.ARPA
- 109.100.IN-ADDR.ARPA
- 110.100.IN-ADDR.ARPA
- 111.100.IN-ADDR.ARPA
- 112.100.IN-ADDR.ARPA
- 113.100.IN-ADDR.ARPA
- 114.100.IN-ADDR.ARPA
- 115.100.IN-ADDR.ARPA
- 116.100.IN-ADDR.ARPA
- 117.100.IN-ADDR.ARPA
- 118.100.IN-ADDR.ARPA
- 119.100.IN-ADDR.ARPA
- 120.100.IN-ADDR.ARPA
- 121.100.IN-ADDR.ARPA



**empty-server**

**Grammar:** `empty-server <string>;`

**Blocks:** options, view

**Tags:** server, zone

Specifies the server name in the returned SOA record for empty zones.

This specifies the server name that appears in the returned SOA record for empty zones. If none is specified, the zone's name is used.

**empty-contact**

**Grammar:** `empty-contact <string>;`

**Blocks:** options, view

**Tags:** server, zone

Specifies the contact name in the returned SOA record for empty zones.

This specifies the contact name that appears in the returned SOA record for empty zones. If none is specified, "." is used.

**empty-zones-enable**

**Grammar:** `empty-zones-enable <boolean>;`

**Blocks:** options, view

**Tags:** server, zone

Enables or disables all empty zones.

This enables or disables all empty zones. By default, they are enabled.

**disable-empty-zone**

**Grammar:** `disable-empty-zone <string>; // may occur multiple times`

**Blocks:** options, view

**Tags:** server, zone

Disables individual empty zones.

This disables individual empty zones. By default, none are disabled. This option can be specified multiple times.

## Content Filtering

**deny-answer-addresses**

**Grammar:** `deny-answer-addresses { <address_match_element>; ... } [ except-from { <string>; ... } ];`

**Blocks:** options, view

**Tags:** query

Rejects A or AAAA records if the corresponding IPv4 or IPv6 addresses match a given *address\_match\_list*.

BIND 9 provides the ability to filter out responses from external DNS servers containing certain types of data in the answer section. Specifically, it can reject address (A or AAAA) records if the corresponding IPv4 or IPv6 addresses match the given *address\_match\_list* of the *deny-answer-addresses* option.

In the *address\_match\_list* of the *deny-answer-addresses* option, only *ip\_address* and *netprefix* are meaningful; any *server\_key* is silently ignored.

**deny-answer-aliases**

**Grammar:** `deny-answer-aliases { <string>; ... } [ except-from { <string>; ... } ];`

**Blocks:** options, view

**Tags:** query

Rejects CNAME or DNAME records if the "alias" name matches a given list of *domain\_name* elements.

It can also reject CNAME or DNAME records if the "alias" name (i.e., the CNAME alias or the substituted query name due to DNAME) matches the given list of *domain\_name* elements of the *deny-answer-aliases* option, where "match" means the alias name is a subdomain of one of the listed domain names. If the optional list is specified in the *except-from* argument, records whose query name matches the list are accepted regardless of the filter setting. Likewise, if the alias name is a subdomain of the corresponding zone, the *deny-answer-aliases* filter does not apply; for example, even if "example.com" is specified for *deny-answer-aliases*,

```
www.example.com. CNAME xxx.example.com.
```

returned by an "example.com" server is accepted.

If a response message is rejected due to the filtering, the entire message is discarded without being cached, and a SERV-FAIL error is returned to the client.

This filtering is intended to prevent "DNS rebinding attacks," in which an attacker, in response to a query for a domain name the attacker controls, returns an IP address within the user's own network or an alias name within the user's own domain. A naive web browser or script could then serve as an unintended proxy, allowing the attacker to get access to an internal node of the local network that could not be externally accessed otherwise. See the paper available at <https://dl.acm.org/doi/10.1145/1315245.1315298> for more details about these attacks.

For example, with a domain named "example.net" and an internal network using an IPv4 prefix 192.0.2.0/24, an administrator might specify the following rules:

```
deny-answer-addresses { 192.0.2.0/24; } except-from { "example.net"; };
deny-answer-aliases { "example.net"; };
```

If an external attacker let a web browser in the local network look up an IPv4 address of "attacker.example.com", the attacker's DNS server would return a response like this:

```
attacker.example.com. A 192.0.2.1
```

in the answer section. Since the rdata of this record (the IPv4 address) matches the specified prefix 192.0.2.0/24, this response would be ignored.

On the other hand, if the browser looked up a legitimate internal web server "www.example.net" and the following response were returned to the BIND 9 server:

```
www.example.net. A 192.0.2.2
```

it would be accepted, since the owner name "www.example.net" matches the `except-from` element, "example.net".

Note that this is not really an attack on the DNS per se. In fact, there is nothing wrong with having an "external" name mapped to an "internal" IP address or domain name from the DNS point of view; it might actually be provided for a legitimate purpose, such as for debugging. As long as the mapping is provided by the correct owner, it either is not possible or does not make sense to detect whether the intent of the mapping is legitimate within the DNS. The "rebinding" attack must primarily be protected at the application that uses the DNS. For a large site, however, it may be difficult to protect all possible applications at once. This filtering feature is provided only to help such an operational environment; turning it on is generally discouraged unless there is no other choice and the attack is a real threat to applications.

Care should be particularly taken if using this option for addresses within 127.0.0.0/8. These addresses are obviously "internal," but many applications conventionally rely on a DNS mapping from some name to such an address. Filtering out DNS records containing this address spuriously can break such applications.

## Response Policy Zone (RPZ) Rewriting

BIND 9 includes a limited mechanism to modify DNS responses for requests analogous to email anti-spam DNS rejection lists. Responses can be changed to deny the existence of domains (NXDOMAIN), deny the existence of IP addresses for domains (NODATA), or contain other IP addresses or data.

### **response-policy**

**Grammar:** `response-policy { zone <string> [ add-soa <boolean> ] [ log <boolean> ] [ max-policy-ttl <duration> ] [ min-update-interval <duration> ] [ policy ( cname | disabled | drop | given | no-op | nodata | nxdomain | passthru | tcp-only <quoted_string> ) ] [ recursive-only <boolean> ] [ nsip-enable <boolean> ] [ nsdname-enable <boolean> ]; ... } [ add-soa <boolean> ] [ break-dnssec <boolean> ] [ max-policy-ttl <duration> ] [ min-update-interval <duration> ] [ min-ns-dots <integer> ] [ nsip-wait-recurse <boolean> ] [ nsdname-wait-recurse <boolean> ] [ qname-wait-recurse <boolean> ] [ recursive-only <boolean> ] [ nsip-enable <boolean> ] [ nsdname-enable <boolean> ] [ dnsrps-enable <boolean> ] [ dnsrps-options { <unspecified-text> } ];`

**Blocks:** options, view

**Tags:** server, query, zone, security

Specifies response policy zones for the view or among global options.

Response policy zones are named in the `response-policy` option for the view, or among the global options if there is no `response-policy` option for the view. Response policy zones are ordinary DNS zones containing RRsets that can be queried normally if allowed. It is usually best to restrict those queries with something like `allow-query { localhost; };`.

A `response-policy` option can support multiple policy zones. To maximize performance, a radix tree is used to quickly identify response policy zones containing triggers that match the current query. This imposes an upper limit of 64 on the number of policy zones in a single `response-policy` option; more than that is a configuration error.

Rules encoded in response policy zones are processed after those defined in *Access Control*. All queries from clients which are not permitted access to the resolver are answered with a status code of REFUSED, regardless of configured RPZ rules.

Five policy triggers can be encoded in RPZ records.

### **RPZ-CLIENT-IP**

IP records are triggered by the IP address of the DNS client. Client IP address triggers are encoded in records that have owner names that are subdomains of `rpz-client-ip`, relativized to the policy zone origin name, and

that encode an address or address block. IPv4 addresses are represented as `prefixlength.B4.B3.B2.B1.rpz-client-ip`. The IPv4 prefix length must be between 1 and 32. All four bytes - B4, B3, B2, and B1 - must be present. B4 is the decimal value of the least significant byte of the IPv4 address as in IN-ADDR.ARPA.

IPv6 addresses are encoded in a format similar to the standard IPv6 text representation, `prefixlength.W8.W7.W6.W5.W4.W3.W2.W1.rpz-client-ip`. Each of W8,...,W1 is a one- to four-digit hexadecimal number representing 16 bits of the IPv6 address as in the standard text representation of IPv6 addresses, but reversed as in IP6.ARPA. (Note that this representation of IPv6 addresses is different from IP6.ARPA, where each hex digit occupies a label.) All 8 words must be present except when one set of consecutive zero words is replaced with `.zz.`, analogous to double colons (`::`) in standard IPv6 text encodings. The IPv6 prefix length must be between 1 and 128.

#### QNAME

QNAME policy records are triggered by query names of requests and targets of CNAME records resolved to generate the response. The owner name of a QNAME policy record is the query name relativized to the policy zone.

#### RPZ-IP

IP triggers are IP addresses in an A or AAAA record in the ANSWER section of a response. They are encoded like client-IP triggers, except as subdomains of `rpz-ip`.

#### RPZ-NSDNAME

NSDNAME triggers match names of authoritative servers for the query name, a parent of the query name, a CNAME for the query name, or a parent of a CNAME. They are encoded as subdomains of `rpz-nsdname`, relativized to the RPZ origin name. NSIP triggers match IP addresses in A and AAAA RRsets for domains that can be checked against NSDNAME policy records. The `nsdname-enable` phrase turns NSDNAME triggers off or on for a single policy zone or for all zones.

If authoritative name servers for the query name are not yet known, *named* recursively looks up the authoritative servers for the query name before applying an RPZ-NSDNAME rule, which can cause a processing delay. To speed up processing at the cost of precision, the `nsdname-wait-recurse` option can be used; when set to `no`, RPZ-NSDNAME rules are only applied when authoritative servers for the query name have already been looked up and cached. If authoritative servers for the query name are not in the cache, the RPZ-NSDNAME rule is ignored, but the authoritative servers for the query name are looked up in the background and the rule is applied to subsequent queries. The default is `yes`, meaning RPZ-NSDNAME rules are always applied, even if authoritative servers for the query name need to be looked up first.

#### RPZ-NSIP

NSIP triggers match the IP addresses of authoritative servers. They are encoded like IP triggers, except as subdomains of `rpz-nsip`. NSDNAME and NSIP triggers are checked only for names with at least `min-ns-dots` dots. The default value of `min-ns-dots` is 1, to exclude top-level domains. The `nsip-enable` phrase turns NSIP triggers off or on for a single policy zone or for all zones.

If a name server's IP address is not yet known, *named* recursively looks up the IP address before applying an RPZ-NSIP rule, which can cause a processing delay. To speed up processing at the cost of precision, the `nsip-wait-recurse` option can be used; when set to `no`, RPZ-NSIP rules are only applied when a name server's IP address has already been looked up and cached. If a server's IP address is not in the cache, the RPZ-NSIP rule is ignored, but the address is looked up in the background and the rule is applied to subsequent queries. The default is `yes`, meaning RPZ-NSIP rules are always applied, even if an address needs to be looked up first.

The query response is checked against all response policy zones, so two or more policy records can be triggered by a response. Because DNS responses are rewritten according to at most one policy record, a single record encoding an action (other than `DISABLED` actions) must be chosen. Triggers, or the records that encode them, are chosen for rewriting in the following order:

1. Choose the triggered record in the zone that appears first in the response-policy option.
2. Prefer CLIENT-IP to QNAME to IP to NSDNAME to NSIP triggers in a single zone.

3. Among NSDNAME triggers, prefer the trigger that matches the smallest name under the DNSSEC ordering.
4. Among IP or NSIP triggers, prefer the trigger with the longest prefix.
5. Among triggers with the same prefix length, prefer the IP or NSIP trigger that matches the smallest IP address.

When the processing of a response is restarted to resolve DNAME or CNAME records and a policy record set has not been triggered, all response policy zones are again consulted for the DNAME or CNAME names and addresses.

RPZ record sets are any types of DNS record, except DNAME or DNSSEC, that encode actions or responses to individual queries. Any of the policies can be used with any of the triggers. For example, while the `TCP-only` policy is commonly used with `client-IP` triggers, it can be used with any type of trigger to force the use of TCP for responses with owner names in a zone.

**PASSTHRU**

The auto-acceptance policy is specified by a CNAME whose target is `rpz-passthru`. It causes the response to not be rewritten and is most often used to "poke holes" in policies for CIDR blocks.

**DROP**

The auto-rejection policy is specified by a CNAME whose target is `rpz-drop`. It causes the response to be discarded. Nothing is sent to the DNS client.

**TCP-Only**

The "slip" policy is specified by a CNAME whose target is `rpz-tcp-only`. It changes UDP responses to short, truncated DNS responses that require the DNS client to try again with TCP. It is used to mitigate distributed DNS reflection attacks.

**NXDOMAIN**

The "domain undefined" response is encoded by a CNAME whose target is the root domain (`.`).

**NODATA**

The empty set of resource records is specified by a CNAME whose target is the wildcard top-level domain (`*.`). It rewrites the response to NODATA or ANCOUNT=0.

**Local Data**

A set of ordinary DNS records can be used to answer queries. Queries for record types not in the set are answered with NODATA.

A special form of local data is a CNAME whose target is a wildcard such as `*.example.com`. It is used as if an ordinary CNAME after the asterisk (`*`) has been replaced with the query name. This special form is useful for query logging in the walled garden's authoritative DNS server.

All of the actions specified in all of the individual records in a policy zone can be overridden with a `policy` clause in the `response-policy` option. An organization using a policy zone provided by another organization might use this mechanism to redirect domains to its own walled garden.

**GIVEN**

The placeholder policy says "do not override but perform the action specified in the zone."

**DISABLED**

The testing override policy causes policy zone records to do nothing but log what they would have done if the policy zone were not disabled. The response to the DNS query is written (or not) according to any triggered policy records that are not disabled. Disabled policy zones should appear first, because they are often not logged if a higher-precedence trigger is found first.

**PASSTHRU; DROP; TCP-Only; NXDOMAIN; NODATA**

These settings each override the corresponding per-record policy.

**CNAME domain**

This causes all RPZ policy records to act as if they were "cname domain" records.

By default, the actions encoded in a response policy zone are applied only to queries that ask for recursion (RD=1). That default can be changed for a single policy zone, or for all response policy zones in a view, with a `recursive-only no` clause. This feature is useful for serving the same zone files both inside and outside an [RFC 1918](#) cloud and using RPZ to delete answers that would otherwise contain [RFC 1918](#) values on the externally visible name server or view.

Also by default, RPZ actions are applied only to DNS requests that either do not request DNSSEC metadata (DO=0) or when no DNSSEC records are available for the requested name in the original zone (not the response policy zone). This default can be changed for all response policy zones in a view with a `break-dnssec yes` clause. In that case, RPZ actions are applied regardless of DNSSEC. The name of the clause option reflects the fact that results rewritten by RPZ actions cannot verify.

No DNS records are needed for a QNAME or Client-IP trigger; the name or IP address itself is sufficient, so in principle the query name need not be recursively resolved. However, not resolving the requested name can leak the fact that response policy rewriting is in use, and that the name is listed in a policy zone, to operators of servers for listed names. To prevent that information leak, by default any recursion needed for a request is done before any policy triggers are considered. Because listed domains often have slow authoritative servers, this behavior can cost significant time. The `qname-wait-recurse no` option overrides the default and enables that behavior when recursion cannot change a non-error response. The option does not affect QNAME or client-IP triggers in policy zones listed after other zones containing IP, NSIP, and NSDNAME triggers, because those may depend on the A, AAAA, and NS records that would be found during recursive resolution. It also does not affect DNSSEC requests (DO=1) unless `break-dnssec yes` is in use, because the response would depend on whether RRSIG records were found during resolution. Using this option can cause error responses such as SERVFAIL to appear to be rewritten, since no recursion is being done to discover problems at the authoritative server.

#### **dnsrps-enable**

**Grammar:** `dnsrps-enable <boolean>;`

**Blocks:** options, view

**Tags:** server, security

Turns on the DNS Response Policy Service (DNSRPS) interface.

The `dnsrps-enable yes` option turns on the DNS Response Policy Service (DNSRPS) interface, if it has been compiled in `named` using `configure --enable-dnsrps`.

#### **dnsrps-options**

**Grammar:** `dnsrps-options { <unspecified-text> };`

**Blocks:** options, view

**Tags:** server, security

Provides additional RPZ configuration settings, which are passed to the DNS Response Policy Service (DNSRPS) provider library.

The block provides additional RPZ configuration settings, which are passed through to the DNSRPS provider library. Multiple DNSRPS settings in an `dnsrps-options` string should be separated with semi-colons (;). The DNSRPS provider, `librpz`, is passed a configuration string consisting of the `dnsrps-options` text, concatenated with settings derived from the `response-policy` statement.

Note: the `dnsrps-options` text should only include configuration settings that are specific to the DNSRPS provider. For example, the DNSRPS provider from Farsight Security takes options such as `dnsrpd-conf`, `dnsrpd-sock`, and `dnzrpd-args` (for details of these options, see the `librpz` documentation). Other RPZ configuration settings could be included in `dnsrps-options` as well, but if `named` were switched back to traditional RPZ by setting `dnsrps-enable` to "no", those options would be ignored.

The TTL of a record modified by RPZ policies is set from the TTL of the relevant record in the policy zone. It is then limited to a maximum value. The `max-policy-ttl` clause changes the maximum number of seconds from its default of 5. For convenience, TTL-style time-unit suffixes may be used to specify the value. It also accepts ISO 8601 duration formats.

For example, an administrator might use this option statement:

```
response-policy { zone "badlist"; };
```

and this zone statement:

```
zone "badlist" {type primary; file "primary/badlist"; allow-query {none;}; };
```

with this zone file:

```
$TTL 1H
@                SOA LOCALHOST. named-mgr.example.com (1 1h 15m 30d 2h)
                NS  LOCALHOST.

; QNAME policy records.  There are no periods (.) after the owner names.
nxdomain.domain.com    CNAME  .                ; NXDOMAIN policy
*.nxdomain.domain.com  CNAME  .                ; NXDOMAIN policy
nodata.domain.com      CNAME  *.              ; NODATA policy
*.nodata.domain.com    CNAME  *.              ; NODATA policy
bad.domain.com          A      10.0.0.1         ; redirect to a walled garden
                        AAAA    2001:2::1
bzone.domain.com        CNAME  garden.example.com.

; do not rewrite (PASSTHRU) OK.DOMAIN.COM
ok.domain.com           CNAME  rpz-passthru.

; redirect x.bzone.domain.com to x.bzone.domain.com.garden.example.com
*.bzone.domain.com      CNAME  *.garden.example.com.

; IP policy records that rewrite all responses containing A records in 127/8
;   except 127.0.0.1
8.0.0.0.127.rpz-ip      CNAME  .
32.1.0.0.127.rpz-ip     CNAME  rpz-passthru.

; NSDNAME and NSIP policy records
ns.domain.com.rpz-nsdname CNAME  .
48.zz.2.2001.rpz-nsip   CNAME  .

; auto-reject and auto-accept some DNS clients
112.zz.2001.rpz-client-ip CNAME  rpz-drop.
8.0.0.0.127.rpz-client-ip CNAME  rpz-drop.

; force some DNS clients and responses in the example.com zone to TCP
16.0.0.1.10.rpz-client-ip CNAME  rpz-tcp-only.
example.com               CNAME  rpz-tcp-only.
*.example.com             CNAME  rpz-tcp-only.
```

RPZ can affect server performance. Each configured response policy zone requires the server to perform one to four additional database lookups before a query can be answered. For example, a DNS server with four policy zones, each with all four kinds of response triggers (QNAME, IP, NSIP, and NSDNAME), requires a total of 17 times as many

database lookups as a similar DNS server with no response policy zones. A BIND 9 server with adequate memory and one response policy zone with QNAME and IP triggers might achieve a maximum queries-per-second (QPS) rate about 20% lower. A server with four response policy zones with QNAME and IP triggers might have a maximum QPS rate about 50% lower.

Responses rewritten by RPZ are counted in the `RPZRewrites` statistics.

The `log` clause can be used to optionally turn off rewrite logging for a particular response policy zone. By default, all rewrites are logged.

The `add-soa` option controls whether the RPZ's SOA record is added to the section for traceback of changes from this zone. This can be set at the individual policy zone level or at the response-policy level. The default is `yes`.

Updates to RPZ zones are processed asynchronously; if there is more than one update pending they are bundled together. If an update to a RPZ zone (for example, via IXFR) happens less than `min-update-interval` seconds after the most recent update, the changes are not carried out until this interval has elapsed. The default is 60 seconds. For convenience, TTL-style time-unit suffixes may be used to specify the value. It also accepts ISO 8601 duration formats.

## Response Rate Limiting

### `rate-limit`

#### Grammar:

```
rate-limit {
    all-per-second <integer>;
    errors-per-second <integer>;
    exempt-clients { <address_match_element>; ... };
    ipv4-prefix-length <integer>;
    ipv6-prefix-length <integer>;
    log-only <boolean>;
    max-table-size <integer>;
    min-table-size <integer>;
    nodata-per-second <integer>;
    nxdomains-per-second <integer>;
    qps-scale <integer>;
    referrals-per-second <integer>;
    responses-per-second <integer>;
    slip <integer>;
    window <integer>;
};
```

**Blocks:** options, view

**Tags:** query

Controls excessive UDP responses, to prevent BIND 9 from being used to amplify reflection denial-of-service (DoS) attacks.

Excessive, almost-identical UDP *responses* can be controlled by configuring a `rate-limit` clause in an `options` or `view` statement. This mechanism keeps authoritative BIND 9 from being used to amplify reflection denial-of-service (DoS) attacks. Short BADCOOKIE errors or truncated (TC=1) responses can be sent to provide rate-limited responses to legitimate clients within a range of forged, attacked IP addresses. Legitimate clients react to dropped responses by retrying, to BADCOOKIE errors by including a server cookie when retrying, and to truncated responses by switching to TCP.

This mechanism is intended for authoritative DNS servers. It can be used on recursive servers, but can slow applications such as SMTP servers (mail receivers) and HTTP clients (web browsers) that repeatedly request the

same domains. When possible, closing "open" recursive servers is better.

Response rate limiting uses a "credit" or "token bucket" scheme. Each combination of identical response and client has a conceptual "account" that earns a specified number of credits every second. A prospective response debits its account by one. Responses are dropped or truncated while the account is negative.

**window**

**Grammar:** `window <integer>;`

**Blocks:** `options.rate-limit`, `view.rate-limit`

**Tags:** query

Specifies the length of time during which responses are tracked.

Responses are tracked within a rolling window of time which defaults to 15 seconds, but which can be configured with the *window* option to any value from 1 to 3600 seconds (1 hour). The account cannot become more positive than the per-second limit or more negative than *window* times the per-second limit. When the specified number of credits for a class of responses is set to 0, those responses are not rate-limited.

**ipv4-prefix-length**

**Grammar:** `ipv4-prefix-length <integer>;`

**Blocks:** `options.rate-limit`, `view.rate-limit`

**Tags:** server

Specifies the prefix lengths of IPv4 address blocks.

**ipv6-prefix-length**

**Grammar:** `ipv6-prefix-length <integer>;`

**Blocks:** `options.rate-limit`, `view.rate-limit`

**Tags:** server

Specifies the prefix lengths of IPv6 address blocks.

The notions of "identical response" and "DNS client" for rate limiting are not simplistic. All responses to an address block are counted as if to a single client. The prefix lengths of address blocks are specified with *ipv4-prefix-length* (default 24) and *ipv6-prefix-length* (default 56).

**responses-per-second**

**Grammar:** `responses-per-second <integer>;`

**Blocks:** `options.rate-limit`, `view.rate-limit`

**Tags:** query

Limits the number of non-empty responses for a valid domain name and record type.

All non-empty responses for a valid domain name (qname) and record type (qtype) are identical and have a limit specified with *responses-per-second* (default 0 or no limit). All valid wildcard domain names are interpreted as the zone's origin name concatenated to the "\*" name.

**nodata-per-second****Grammar:** `nodata-per-second <integer>;`**Blocks:** `options.rate-limit`, `view.rate-limit`**Tags:** `query`

Limits the number of empty (NODATA) responses for a valid domain name.

All empty (NODATA) responses for a valid domain, regardless of query type, are identical. Responses in the NODATA class are limited by *nodata-per-second* (default *responses-per-second*).

**nxdomains-per-second****Grammar:** `nxdomains-per-second <integer>;`**Blocks:** `options.rate-limit`, `view.rate-limit`**Tags:** `query`

Limits the number of undefined subdomains for a valid domain name.

Requests for any and all undefined subdomains of a given valid domain result in NXDOMAIN errors, and are identical regardless of query type. They are limited by *nxdomains-per-second* (default *responses-per-second*). This controls some attacks using random names, but can be relaxed or turned off (set to 0) on servers that expect many legitimate NXDOMAIN responses, such as from anti-spam rejection lists.

**referrals-per-second****Grammar:** `referrals-per-second <integer>;`**Blocks:** `options.rate-limit`, `view.rate-limit`**Tags:** `query`

Limits the number of referrals or delegations to a server for a given domain.

Referrals or delegations to the server of a given domain are identical and are limited by *referrals-per-second* (default *responses-per-second*).

Responses generated from local wildcards are counted and limited as if they were for the parent domain name. This controls flooding using `random.wild.example.com`.

All requests that result in DNS errors other than NXDOMAIN, such as SERVFAIL and FORMERR, are identical regardless of requested name (qname) or record type (qtype). This controls attacks using invalid requests or distant, broken authoritative servers.

**errors-per-second****Grammar:** `errors-per-second <integer>;`**Blocks:** `options.rate-limit`, `view.rate-limit`**Tags:** `server`

Limits the number of errors for a valid domain name and record type.

By default the limit on errors is the same as the *responses-per-second* value, but it can be set separately with *errors-per-second*.

**slip****Grammar:** `slip <integer>;`**Blocks:** `options.rate-limit`, `view.rate-limit`**Tags:** query

Sets the number of "slipped" responses to minimize the use of forged source addresses for an attack.

Many attacks using DNS involve UDP requests with forged source addresses. Rate limiting prevents the use of BIND 9 to flood a network with responses to requests with forged source addresses, but could let a third party block responses to legitimate requests. There is a mechanism that can answer some legitimate requests from a client whose address is being forged in a flood. Setting `slip` to 2 (its default) causes every other UDP request without a valid server cookie to be answered with a small response. The small size and reduced frequency, and resulting lack of amplification, of "slipped" responses make them unattractive for reflection DoS attacks. `slip` must be between 0 and 10. A value of 0 does not "slip"; no small responses are sent due to rate limiting. Rather, all responses are dropped. A value of 1 causes every response to slip; values between 2 and 10 cause every nth response to slip.

If the request included a client cookie, then a "slipped" response is a BADCOOKIE error with a server cookie, which allows a legitimate client to include the server cookie to be exempted from the rate limiting when it retries the request. If the request did not include a cookie, then a "slipped" response is a truncated (TC=1) response, which prompts a legitimate client to switch to TCP and thus be exempted from the rate limiting. Some error responses, including REFUSED and SERVFAIL, cannot be replaced with truncated responses and are instead leaked at the `slip` rate.

(Note: dropped responses from an authoritative server may reduce the difficulty of a third party successfully forging a response to a recursive resolver. The best security against forged responses is for authoritative operators to sign their zones using DNSSEC and for resolver operators to validate the responses. When this is not an option, operators who are more concerned with response integrity than with flood mitigation may consider setting `slip` to 1, causing all rate-limited responses to be truncated rather than dropped. This reduces the effectiveness of rate-limiting against reflection attacks.)

**qps-scale****Grammar:** `qps-scale <integer>;`**Blocks:** `options.rate-limit`, `view.rate-limit`**Tags:** query

Tightens defenses during DNS attacks by scaling back the ratio of the current query-per-second rate.

When the approximate query-per-second rate exceeds the `qps-scale` value, the `responses-per-second`, `errors-per-second`, `nxdomains-per-second`, and `all-per-second` values are reduced by the ratio of the current rate to the `qps-scale` value. This feature can tighten defenses during attacks. For example, with `qps-scale 250`; `responses-per-second 20`; and a total query rate of 1000 queries/second for all queries from all DNS clients including via TCP, then the effective responses/second limit changes to  $(250/1000)*20$ , or 5. Responses to requests that included a valid server cookie, and responses sent via TCP, are not limited but are counted to compute the query-per-second rate.

**exempt-clients****Grammar:** `exempt-clients { <address_match_element>; ... };`**Blocks:** `options.rate-limit`, `view.rate-limit`**Tags:** query

Exempts specific clients or client groups from rate limiting.

Communities of DNS clients can be given their own parameters or no rate limiting by putting *rate-limit* statements in *view* statements instead of in the global *option* statement. A *rate-limit* statement in a view replaces, rather than supplements, a *rate-limit* statement among the main options.

DNS clients within a view can be exempted from rate limits with the *exempt-clients* clause.

**all-per-second**

**Grammar:** *all-per-second* <integer>;

**Blocks:** options.rate-limit, view.rate-limit

**Tags:** query

Limits UDP responses of all kinds.

UDP responses of all kinds can be limited with the *all-per-second* phrase. This rate limiting is unlike the rate limiting provided by *responses-per-second*, *errors-per-second*, and *nxdomains-per-second* on a DNS server, which are often invisible to the victim of a DNS reflection attack. Unless the forged requests of the attack are the same as the legitimate requests of the victim, the victim's requests are not affected. Responses affected by an *all-per-second* limit are always dropped; the *slip* value has no effect. An *all-per-second* limit should be at least 4 times as large as the other limits, because single DNS clients often send bursts of legitimate requests. For example, the receipt of a single mail message can prompt requests from an SMTP server for NS, PTR, A, and AAAA records as the incoming SMTP/TCP/IP connection is considered. The SMTP server can need additional NS, A, AAAA, MX, TXT, and SPF records as it considers the SMTP `Mail From` command. Web browsers often repeatedly resolve the same names that are duplicated in HTML <IMG> tags in a page. *all-per-second* is similar to the rate limiting offered by firewalls but is often inferior. Attacks that justify ignoring the contents of DNS responses are likely to be attacks on the DNS server itself. They usually should be discarded before the DNS server spends resources making TCP connections or parsing DNS requests, but that rate limiting must be done before the DNS server sees the requests.

**max-table-size**

**Grammar:** *max-table-size* <integer>;

**Blocks:** options.rate-limit, view.rate-limit

**Tags:** server

Sets the maximum size of the table used to track requests and rate-limit responses.

**min-table-size**

**Grammar:** *min-table-size* <integer>;

**Blocks:** options.rate-limit, view.rate-limit

**Tags:** query

Sets the minimum size of the table used to track requests and rate-limit responses.

The maximum size of the table used to track requests and rate-limit responses is set with *max-table-size*. Each entry in the table is between 40 and 80 bytes. The table needs approximately as many entries as the number of requests received per second. The default is 20,000. To reduce the cold start of growing the table, *min-table-size* (default 500) can set the minimum table size. Enable *rate-limit* category logging to monitor expansions of the table and inform choices for the initial and maximum table size.

**log-only**

**Grammar:** `log-only <boolean>;`

**Blocks:** `options.rate-limit`, `view.rate-limit`

**Tags:** logging, query

Tests rate-limiting parameters without actually dropping any requests.

Use `log-only yes` to test rate-limiting parameters without actually dropping any requests.

Responses dropped by rate limits are included in the `RateDropped` and `QryDropped` statistics. Responses that are truncated by rate limits are included in `RateSlipped` and `RespTruncated`.

**NXDOMAIN Redirection**

`named` supports NXDOMAIN redirection via two methods:

- `Redirect zone`
- Redirect namespace

With either method, when `named` gets an NXDOMAIN response it examines a separate namespace to see if the NXDOMAIN response should be replaced with an alternative response.

With a redirect zone (`zone "." { type redirect; };`), the data used to replace the NXDOMAIN is held in a single zone which is not part of the normal namespace. All the redirect information is contained in the zone; there are no delegations.

**`nxdomain-redirect`**

**Grammar:** `nxdomain-redirect <string>;`

**Blocks:** `options`, `view`

**Tags:** query

Appends the specified suffix to the original query name, when replacing an NXDOMAIN with a redirect namespace.

With a redirect namespace (`option { nxdomain-redirect <suffix> };`), the data used to replace the NXDOMAIN is part of the normal namespace and is looked up by appending the specified suffix to the original query name. This roughly doubles the cache required to process NXDOMAIN responses, as both the original NXDOMAIN response and the replacement data (or an NXDOMAIN indicating that there is no replacement) must be stored.

If both a redirect zone and a redirect namespace are configured, the redirect zone is tried first.

**8.2.15 `server` Block Grammar**

**`server`**

**Grammar:**

```
server <netprefix> {
    bogus <boolean>;
    edns <boolean>;
    edns-udp-size <integer>;
    edns-version <integer>;
    keys <server_key>;
```

(continues on next page)

(continued from previous page)

```

max-udp-size <integer>;
notify-source ( <ipv4_address> | * );
notify-source-v6 ( <ipv6_address> | * );
padding <integer>;
provide-ixfr <boolean>;
query-source [ address ] ( <ipv4_address> | * );
query-source-v6 [ address ] ( <ipv6_address> | * );
request-expire <boolean>;
request-ixfr <boolean>;
request-nsid <boolean>;
send-cookie <boolean>;
tcp-keepalive <boolean>;
tcp-only <boolean>;
transfer-format ( many-answers | one-answer );
transfer-source ( <ipv4_address> | * );
transfer-source-v6 ( <ipv6_address> | * );
transfers <integer>;
}; // may occur multiple times

```

**Blocks:** topmost, view**Tags:** server

Defines characteristics to be associated with a remote name server.

## 8.2.16 `server` Block Definition and Usage

The `server` statement defines characteristics to be associated with a remote name server. If a prefix length is specified, then a range of servers is covered. Only the most specific server clause applies, regardless of the order in `named.conf`.

The `server` statement can occur at the top level of the configuration file or inside a `view` statement. If a `view` statement contains one or more `server` statements, only those apply to the view and any top-level ones are ignored. If a view contains no `server` statements, any top-level `server` statements are used as defaults.

### **bogus**

**Grammar:** bogus <boolean>;**Blocks:** server, view.server**Tags:** server

Allows a remote server to be ignored.

If a remote server is giving out bad data, marking it as bogus prevents further queries to it. The default value of `bogus` is no.

### **edns**

**Grammar:** edns <boolean>;**Blocks:** server, view.server**Tags:** server

Controls the use of the EDNS0 (RFC 2671) feature.

The *edns* clause determines whether the local server attempts to use EDNS when communicating with the remote server. The default is *yes*.

**edns-version**

**Grammar:** `edns-version <integer>;`

**Blocks:** server, view.server

**Tags:** server

Sets the maximum EDNS VERSION that is sent to the server(s) by the resolver.

The *edns-version* option sets the maximum EDNS VERSION that is sent to the server(s) by the resolver. The actual EDNS version sent is still subject to normal EDNS version-negotiation rules (see [RFC 6891](#)), the maximum EDNS version supported by the server, and any other heuristics that indicate that a lower version should be sent. This option is intended to be used when a remote server reacts badly to a given EDNS version or higher; it should be set to the highest version the remote server is known to support. Valid values are 0 to 255; higher values are silently adjusted. This option is not needed until higher EDNS versions than 0 are in use.

**padding**

**Grammar:** `padding <integer>;`

**Blocks:** server, view.server

**Tags:** server

Adds EDNS Padding options to outgoing messages to increase the packet size.

The option adds EDNS Padding options to outgoing messages, increasing the packet size to a multiple of the specified block size. Valid block sizes range from 0 (the default, which disables the use of EDNS Padding) to 512 bytes. Larger values are reduced to 512, with a logged warning. Note: this option is not currently compatible with TSIG or SIG(0), as the EDNS OPT record containing the padding would have to be added to the packet after it had already been signed.

**tcp-only**

**Grammar:** `tcp-only <boolean>;`

**Blocks:** server, view.server

**Tags:** server

Sets the transport protocol to TCP.

The option sets the transport protocol to TCP. The default is to use the UDP transport and to fallback on TCP only when a truncated response is received.

**tcp-keepalive**

**Grammar:** `tcp-keepalive <boolean>;`

**Blocks:** server, view.server

**Tags:** server

Adds EDNS TCP keepalive to messages sent over TCP.

The option adds EDNS TCP keepalive to messages sent over TCP. Note that currently idle timeouts in responses are ignored.

**transfers****Grammar:** `transfers <integer>;`**Blocks:** `server`, `view.server`**Tags:** `server`

Limits the number of concurrent inbound zone transfers from a server.

`transfers` is used to limit the number of concurrent inbound zone transfers from the specified server. If no `transfers` clause is specified, the limit is set according to the `transfers-per-ns` option.

**keys****Blocks:** `dnssec-policy`, `server`, `view.server`**Tags:** `server`, `security`

Specifies one or more `server_key`s to be used with a remote server.

**Warning**

Not to be confused with `keys` in `dnssec-policy` specification. Although statements with the same name exist in both contexts, they refer to fundamentally incompatible concepts.

In the context of a `server` block, the option identifies a `server_key` defined by the `key` statement, to be used for transaction security (see *TSIG*) when talking to the remote server. When a request is sent to the remote server, a request signature is generated using the key specified here and appended to the message. A request originating from the remote server is not required to be signed by this key.

Only a single key per server is currently supported.

It is possible to override the following values defined in `view` and `options` blocks:

- `edns-udp-size`
- `max-udp-size`
- `notify-source-v6`
- `notify-source`
- `provide-ixfr`
- `query-source-v6`
- `query-source`
- `request-expire`
- `request-ixfr`
- `request-nsid`
- `send-cookie`
- `transfer-format`
- `transfer-source-v6`
- `transfer-source`

## 8.2.17 *statistics-channels* Block Grammar

### **statistics-channels**

#### **Grammar:**

```
statistics-channels {
    inet ( <ipv4_address> | <ipv6_address> | * ) [ port ( <integer> | * ) ] [
↳allow { <address_match_element>; ... } ]; // may occur multiple times
}; // may occur multiple times
```

**Blocks:** topmost

**Tags:** logging

Specifies the communication channels to be used by system administrators to access statistics information on the name server.

## 8.2.18 *statistics-channels* Block Definition and Usage

The *statistics-channels* statement declares communication channels to be used by system administrators to get access to statistics information on the name server.

This statement is intended to be flexible to support multiple communication protocols in the future, but currently only HTTP access is supported. It requires that BIND 9 be compiled with libxml2 and/or json-c (also known as libjson0); the *statistics-channels* statement is still accepted even if it is built without the library, but any HTTP access fails with an error.

An *inet* control channel is a TCP socket listening at the specified *port* on the specified *ip\_address*, which can be an IPv4 or IPv6 address. An *ip\_address* of \* (asterisk) is interpreted as the IPv4 wildcard address; connections are accepted on any of the system's IPv4 addresses. To listen on the IPv6 wildcard address, use an *ip\_address* of ::.

If no port is specified, port 80 is used for HTTP channels. The asterisk (\*) cannot be used for *port*.

Attempts to open a statistics channel are restricted by the optional *allow* clause. Connections to the statistics channel are permitted based on the *address\_match\_list*. If no *allow* clause is present, *named* accepts connection attempts from any address. Since the statistics may contain sensitive internal information, the source of connection requests must be restricted appropriately so that only trusted parties can access the statistics channel.

Gathering data exposed by the statistics channel locks various subsystems in *named*, which could slow down query processing if statistics data is requested too often.

An issue in the statistics channel would be considered a security issue only if it could be exploited by unprivileged users circumventing the access control list. In other words, any issue in the statistics channel that could be used to access information unavailable otherwise, or to crash *named*, is not considered a security issue if it can be avoided through the use of a secure configuration.

If no *statistics-channels* statement is present, *named* does not open any communication channels.

The statistics are available in various formats and views, depending on the URI used to access them. For example, if the statistics channel is configured to listen on 127.0.0.1 port 8888, then the statistics are accessible in XML format at <http://127.0.0.1:8888/> or <http://127.0.0.1:8888/xml>. A CSS file is included, which can format the XML statistics into tables when viewed with a stylesheet-capable browser, and into charts and graphs using the Google Charts API when using a JavaScript-capable browser.

Broken-out subsets of the statistics can be viewed at <http://127.0.0.1:8888/xml/v3/status> (server uptime and last reconfiguration time), <http://127.0.0.1:8888/xml/v3/server> (server and resolver statistics), <http://127.0.0.1:8888/xml/v3/zones> (zone statistics), <http://127.0.0.1:8888/xml/v3/net> (network status and socket statistics), <http://127.0.0.1:8888/xml/v3/>

mem (memory manager statistics), <http://127.0.0.1:8888/xml/v3/tasks> (task manager statistics), and <http://127.0.0.1:8888/xml/v3/traffic> (traffic sizes).

The full set of statistics can also be read in JSON format at <http://127.0.0.1:8888/json>, with the broken-out subsets at <http://127.0.0.1:8888/json/v1/status> (server uptime and last reconfiguration time), <http://127.0.0.1:8888/json/v1/server> (server and resolver statistics), <http://127.0.0.1:8888/json/v1/zones> (zone statistics), <http://127.0.0.1:8888/json/v1/net> (network status and socket statistics), <http://127.0.0.1:8888/json/v1/mem> (memory manager statistics), <http://127.0.0.1:8888/json/v1/tasks> (task manager statistics), and <http://127.0.0.1:8888/json/v1/traffic> (traffic sizes).

## 8.2.19 *tls* Block Grammar

**tls**

**Grammar:**

```
tls <string> {
    ca-file <quoted_string>;
    cert-file <quoted_string>;
    ciphers <string>;
    dhparam-file <quoted_string>;
    key-file <quoted_string>;
    prefer-server-ciphers <boolean>;
    protocols { <string>; ... };
    remote-hostname <quoted_string>;
    session-tickets <boolean>;
}; // may occur multiple times
```

**Blocks:** topmost

**Tags:** security

Configures a TLS connection.

## 8.2.20 *tls* Block Definition and Usage

The *tls* statement is used to configure a TLS connection; this configuration can then be referenced by a *listen-on* or *listen-on-v6* statement to cause *named* to listen for incoming requests via TLS, or in the *primaries* statement for a zone of *type secondary* to cause zone transfer requests to be sent via TLS.

*tls* can only be set at the top level of *named.conf*.

The following options can be specified in a *tls* statement:

**key-file**

**Grammar:** key-file <quoted\_string>;

**Blocks:** tls

**Tags:** server, security

Specifies the path to a file containing the private TLS key for a connection.

Path to a file containing the private TLS key to be used for the connection.

**cert-file****Grammar:** `cert-file <quoted_string>;`**Blocks:** `tls`**Tags:** `server, security`

Specifies the path to a file containing the TLS certificate for a connection.

Path to a file containing the TLS certificate to be used for the connection.

**ca-file****Grammar:** `ca-file <quoted_string>;`**Blocks:** `tls`**Tags:** `server, security`

Specifies the path to a file containing TLS certificates for trusted CA authorities, used to verify remote peer certificates.

Path to a file containing trusted CA authorities' TLS certificates used to verify remote peer certificates. Specifying this option enables remote peer certificates' verification. For incoming connections, specifying this option makes BIND require a valid TLS certificate from a client. In the case of outgoing connections, if `remote-hostname` is not specified, then the remote server IP address is used instead.

**dhparam-file****Grammar:** `dhparam-file <quoted_string>;`**Blocks:** `tls`**Tags:** `server, security`

Specifies the path to a file containing Diffie-Hellman parameters, for enabling cipher suites.

Path to a file containing Diffie-Hellman parameters, which is needed to enable the cipher suites depending on the Diffie-Hellman ephemeral key exchange (DHE). Having these parameters specified is essential for enabling perfect forward secrecy capable ciphers in TLSv1.2.

**remote-hostname****Grammar:** `remote-hostname <quoted_string>;`**Blocks:** `tls`**Tags:** `security`

Specifies the expected hostname in the TLS certificate of the remote server.

The expected hostname in the TLS certificate of the remote server. This option enables a remote server certificate verification. If `ca-file` is not specified, then the platform-specific certificates store is used for verification. This option is used when connecting to a remote peer only and, thus, is ignored when `tls` statements are referenced by `listen-on` or `listen-on-v6` statements.

**protocols**

**Grammar:** `protocols { <string>; ... };`

**Blocks:** `tls`

**Tags:** `security`

Specifies the allowed versions of the TLS protocol.

Allowed versions of the TLS protocol. TLS version 1.2 and higher are supported, depending on the cryptographic library in use. Multiple versions might be specified (e.g. `protocols { TLSv1.2; TLSv1.3; };`).

**ciphers**

**Grammar:** `ciphers <string>;`

**Blocks:** `tls`

**Tags:** `security`

Specifies a list of allowed ciphers.

Cipher list which defines allowed ciphers, such as `HIGH:!aNULL:!MD5:!SHA1:!SHA256:!SHA384`. The string must be formed according to the rules specified in the OpenSSL documentation (see <https://docs.openssl.org/1.1.1/man1/ciphers/> for details).

**prefer-server-ciphers**

**Grammar:** `prefer-server-ciphers <boolean>;`

**Blocks:** `tls`

**Tags:** `server, security`

Specifies that server ciphers should be preferred over client ones.

Specifies that server ciphers should be preferred over client ones.

**session-tickets**

**Grammar:** `session-tickets <boolean>;`

**Blocks:** `tls`

**Tags:** `security`

Enables or disables session resumption through TLS session tickets.

Enables or disables session resumption through TLS session tickets, as defined in RFC5077. Disabling the stateless session tickets might be required in the cases when forward secrecy is needed, or the TLS certificate and key pair is planned to be used across multiple BIND instances.

**Warning**

TLS configuration is subject to change and incompatible changes might be introduced in the future. Users of TLS are encouraged to carefully read release notes when upgrading.

The options described above are used to control different aspects of TLS functioning. Thus, most of them have no well-defined default values, as these depend on the cryptographic library version in use and system-wide cryptographic policy. On the other hand, by specifying the needed options one could have a uniform configuration deployable across a range of platforms.

An example of privacy-oriented, perfect forward secrecy enabled configuration can be found below. It can be used as a starting point.

```
tls local-tls {
    key-file "/path/to/key.pem";
    cert-file "/path/to/fullchain_cert.pem";
    dhparam-file "/path/to/dhparam.pem";
    ciphers "HIGH:!kRSA:!aNULL:!eNULL:!RC4:!3DES:!MD5:!EXP:!PSK:!SRP:!DSS:!SHA1:!  
→SHA256:!SHA384";
    prefer-server-ciphers yes;
    session-tickets no;
};
```

A Diffie-Hellman parameters file can be generated using e.g. OpenSSL, like follows:

```
openssl dhparam -out /path/to/dhparam.pem <3072_or_4096>
```

Ensure that it gets generated on a machine with enough entropy from external sources (e.g. the computer you work on should be fine, the remote virtual machine or server might be not). These files do not contain any sensitive data and can be shared if required.

There are two built-in TLS connection configurations: `ephemeral`, uses a temporary key and certificate created for the current *named* session only, and `none`, which can be used when setting up an HTTP listener with no encryption.

The main motivation behind having the `ephemeral` configuration is to aid in testing, as trusted certificate authorities do not issue the certificates associated with this configuration. Thus, these certificates will never be trusted by any clients that verify TLS certificates; they provide encryption of the traffic but no authentication of the transmission channel. That might be enough in the case of deployment in a controlled environment.

It should be noted that on reconfiguration, the `ephemeral` TLS key and the certificate are recreated, and all TLS certificates and keys, as well as associated data, are reloaded from the disk. In that case, listening sockets associated with TLS remain intact.

Please keep in mind that performing a reconfiguration can cause a short interruption in BIND's ability to process inbound client packets. The length of interruption is environment- and configuration-specific. A good example of when reconfiguration is necessary is when TLS keys and certificates are updated on the disk.

BIND supports the following TLS authentication mechanisms described in the RFC 9103, Section 9.3: Opportunistic TLS, Strict TLS, and Mutual TLS.

Opportunistic TLS provides encryption for data but does not provide any authentication for the channel. This mode is the default one and it is used whenever `remote-hostname` and `ca-file` options are not set in `tls` statements in use. RFC 9103 allows optional fallback to clear-text DNS in the cases when TLS is not available. Still, BIND intentionally does not support that in order to protect from unexpected data leaks due to misconfiguration. Both BIND and its complementary tools either successfully establish a secure channel via TLS when instructed to do so or fail to establish a connection otherwise.

Strict TLS provides server authentication via a pre-configured hostname for outgoing connections. This mechanism offers both channel confidentiality and channel authentication (of the server). In order to achieve Strict TLS, one needs to use *remote-hostname* and, optionally, *ca-file* options in the *tls* statements used for establishing outgoing connections (e.g. the ones used to download zone from primaries via TLS). Providing any of the mentioned options will enable server authentication. If *remote-hostname* is provided but *ca-file* is missing, then the platform-specific certificate authority certificates are used for authentication. The set roughly corresponds to the one used by WEB-browsers to authenticate HTTPS hosts. On the other hand, if *ca-file* is provided but *remote-hostname* is missing, then the remote side's IP address is used instead.

Mutual TLS is an extension to Strict TLS that provides channel confidentiality and mutual channel authentication. It builds up upon the clients offering client certificates when establishing connections and then doing the server authentication as in the case of Strict TLS. The server verifies the provided client certificates and accepts the TLS connection in case of successful verification or rejects it otherwise. In order to instruct the server to require and verify client TLS certificates, one needs to specify the *ca-file* option in *tls* configurations used to configure server listeners. The provided file must contain certificate authority certificates used to issue client certificates. In most cases, one should build one's own TLS certificate authority specifically to issue client certificates and include the certificate authority certificate into the file.

For authenticating zone transfers over TLS, Mutual TLS might be considered a standalone solution, while Strict TLS paired with TSIG-based authentication and, optionally, IP-based access lists, might be considered acceptable for most practical purposes. Mutual TLS has the advantage of not requiring TSIG and thus, not having security issues related to shared cryptographic secrets.

## 8.2.21 *http* Block Grammar

**http**

**Grammar:**

```
http <string> {
    endpoints { <quoted_string>; ... };
    listener-clients <integer>;
    streams-per-connection <integer>;
}; // may occur multiple times
```

**Blocks:** topmost

**Tags:** server, query

Configures HTTP endpoints on which to listen for DNS-over-HTTPS (DoH) queries.

## 8.2.22 *http* Block Definition and Usage

The *http* statement is used to configure HTTP endpoints on which to listen for DNS-over-HTTPS (DoH) queries. This configuration can then be referenced by a *listen-on* or *listen-on-v6* statement to cause *named* to listen for incoming requests over HTTPS.

*http* can only be set at the top level of *named.conf*.

The following options can be specified in an *http* statement:

**endpoints**

**Grammar:** endpoints { <quoted\_string>; ... };

**Blocks:** http

**Tags:** server, query

Specifies a list of HTTP query paths on which to listen.

A list of HTTP query paths on which to listen. This is the portion of an **RFC 3986**-compliant URI following the hostname; it must be an absolute path, beginning with "/". The default value is `"/dns-query"`, if omitted.

**listener-clients**

**Grammar:** `listener-clients <integer>;`

**Blocks:** `http`

**Tags:** `server, query`

Specifies a per-listener quota for active connections.

The option specifies a per-listener quota for active connections.

**streams-per-connection**

**Grammar:** `streams-per-connection <integer>;`

**Blocks:** `http`

**Tags:** `server, query`

Specifies the maximum number of concurrent HTTP/2 streams over an HTTP/2 connection.

The option specifies the hard limit on the number of concurrent HTTP/2 streams over an HTTP/2 connection.

Any of the options above could be omitted. In such a case, a global value specified in the `options` statement is used (see `http-listener-clients`, `http-streams-per-connection`).

For example, the following configuration enables DNS-over-HTTPS queries on all local addresses:

```
http local {
    endpoints { "/dns-query"; };
};

options {
    ....
    listen-on tls ephemeral http local { any; };
    listen-on-v6 tls ephemeral http local { any; };
};
```

### 8.2.23 `trust-anchors` Block Grammar

**trust-anchors**

**Grammar:** `trust-anchors { <string> ( static-key | initial-key | static-ds | initial-ds ) <integer> <integer> <integer> <quoted_string>; ... }; // may occur multiple times`

**Blocks:** `topmost, view`

**Tags:** `dnssec`

Defines *DNSSEC* trust anchors.

## 8.2.24 *trust-anchors* Block Definition and Usage

The *trust-anchors* statement defines DNSSEC trust anchors. DNSSEC is described in *DNSSEC*.

A trust anchor is defined when the public key or public key digest for a non-authoritative zone is known but cannot be securely obtained through DNS, either because it is the DNS root zone or because its parent zone is unsigned. Once a key or digest has been configured as a trust anchor, it is treated as if it has been validated and proven secure.

The resolver attempts DNSSEC validation on all DNS data in subdomains of configured trust anchors. Validation below specified names can be temporarily disabled by using *rndc nta*, or permanently disabled with the *validate-except* option.

All keys listed in *trust-anchors*, and their corresponding zones, are deemed to exist regardless of what parent zones say. Only keys configured as trust anchors are used to validate the DNSKEY RRset for the corresponding name. The parent's DS RRset is not used.

*trust-anchors* may be set at the top level of *named.conf* or within a view. If it is set in both places, the configurations are additive; keys defined at the top level are inherited by all views, but keys defined in a view are only used within that view.

The *trust-anchors* statement can contain multiple trust-anchor entries, each consisting of a domain name, followed by an "anchor type" keyword indicating the trust anchor's format, followed by the key or digest data.

If the anchor type is *static-key* or *initial-key*, then it is followed with the key's flags, protocol, and algorithm, plus the Base64 representation of the public key data. This is identical to the text representation of a DNSKEY record. Spaces, tabs, newlines, and carriage returns are ignored in the key data, so the configuration may be split into multiple lines.

If the anchor type is *static-ds* or *initial-ds*, it is followed with the key tag, algorithm, digest type, and the hexadecimal representation of the key digest. This is identical to the text representation of a DS record. Spaces, tabs, newlines, and carriage returns are ignored.

Trust anchors configured with the *static-key* or *static-ds* anchor types are immutable, while keys configured with *initial-key* or *initial-ds* can be kept up-to-date automatically, without intervention from the resolver operator. (*static-key* keys are identical to keys configured using the deprecated *trusted-keys* statement.)

Suppose, for example, that a zone's key-signing key was compromised, and the zone owner had to revoke and replace the key. A resolver which had the original key configured using *static-key* or *static-ds* would be unable to validate this zone any longer; it would reply with a SERVFAIL response code. This would continue until the resolver operator had updated the *trust-anchors* statement with the new key.

If, however, the trust anchor had been configured using *initial-key* or *initial-ds* instead, the zone owner could add a "stand-by" key to the zone in advance. *named* would store the stand-by key, and when the original key was revoked, *named* would be able to transition smoothly to the new key. It would also recognize that the old key had been revoked and cease using that key to validate answers, minimizing the damage that the compromised key could do. This is the process used to keep the ICANN root DNSSEC key up-to-date.

Whereas *static-key* and *static-ds* trust anchors continue to be trusted until they are removed from *named.conf*, an *initial-key* or *initial-ds* is only trusted *once*: for as long as it takes to load the managed key database and start the **RFC 5011** key maintenance process.

It is not possible to mix static with initial trust anchors for the same domain name.

The first time *named* runs with an *initial-key* or *initial-ds* configured in *named.conf*, it fetches the DNSKEY RRset directly from the zone apex, and validates it using the trust anchor specified in *trust-anchors*. If the DNSKEY RRset is validly signed by a key matching the trust anchor, then it is used as the basis for a new managed-keys database.

From that point on, whenever *named* runs, it sees the *initial-key* or *initial-ds* listed in *trust-anchors*, checks to make sure **RFC 5011** key maintenance has already been initialized for the specified domain, and if so, simply moves

on. The key specified in the `trust-anchors` statement is not used to validate answers; it is superseded by the key or keys stored in the managed-keys database.

The next time `named` runs after an `initial-key` or `initial-ds` has been *removed* from the `trust-anchors` statement (or changed to a `static-key` or `static-ds`), the corresponding zone is removed from the managed-keys database, and **RFC 5011** key maintenance is no longer used for that domain.

In the current implementation, the managed-keys database is stored as a master-format zone file.

On servers which do not use views, this file is named `managed-keys.bind`. When views are in use, there is a separate managed-keys database for each view; the filename is the view name (or, if a view name contains characters which would make it illegal as a filename, a hash of the view name), followed by the suffix `.mkeys`.

When the key database is changed, the zone is updated. As with any other dynamic zone, changes are written into a journal file, e.g., `managed-keys.bind.jnl` or `internal.mkeys.jnl`. Changes are committed to the primary file as soon as possible afterward, usually within 30 seconds. Whenever `named` is using automatic key maintenance, the zone file and journal file can be expected to exist in the working directory. (For this reason, among others, the working directory should be always be writable by `named`.)

If the `dnssec-validation` option is set to `auto`, `named` automatically initializes an `initial-key` for the root zone. The key that is used to initialize the key-maintenance process is stored in `bind.keys`; the location of this file can be overridden with the `bindkeys-file` option. As a fallback in the event no `bind.keys` can be found, the initializing key is also compiled directly into `named`.

## 8.2.25 `dnssec-policy` Block Grammar

`dnssec-policy`

**Grammar options, view, zone (primary, secondary):** `dnssec-policy <string>;`

**Grammar topmost:**

```
dnssec-policy <string> {
    dnskey-ttl <duration>;
    keys { ( csk | ksk | zsk ) [ ( key-directory ) ] lifetime <duration_or_
↪unlimited> algorithm <string> [ <integer> ]; ... };
    max-zone-ttl <duration>;
    nsec3param [ iterations <integer> ] [ optout <boolean> ] [ salt-length
↪<integer> ];
    parent-ds-ttl <duration>;
    parent-propagation-delay <duration>;
    parent-registration-delay <duration>; // obsolete
    publish-safety <duration>;
    purge-keys <duration>;
    retire-safety <duration>;
    signatures-jitter <duration>;
    signatures-refresh <duration>;
    signatures-validity <duration>;
    signatures-validity-dnskey <duration>;
    zone-propagation-delay <duration>;
}; // may occur multiple times
```

**Blocks:** topmost, options, view, zone (primary, secondary)

**Tags:** dnssec

Defines a key and signing policy (KASP) for zones.

## 8.2.26 *dnssec-policy* Block Definition and Usage

The *dnssec-policy* statement defines a key and signing policy (KASP) for zones.

A KASP determines how one or more zones are signed with DNSSEC. For example, it specifies how often keys should roll, which cryptographic algorithms to use, and how often RRSIG records need to be refreshed. Multiple key and signing policies can be configured with unique policy names.

A policy for a zone is selected using a *dnssec-policy* statement in the *zone* block, specifying the name of the policy that should be used.

**There are three built-in policies:**

- *default*, which uses the *default policy*,
- *insecure*, to be used when you want to gracefully unsign your zone,
- *none*, which means no DNSSEC policy (the same as not selecting *dnssec-policy* at all; the zone is not signed.)

Keys are not shared among zones, which means that one set of keys per zone is generated even if they have the same policy. If multiple views are configured with different versions of the same zone, each separate version uses the same set of signing keys.

If the expected key files that were previously observed have gone missing or are inaccessible, key management is halted. This will prevent rollovers from being started if there is a temporary file access issue. If this problem is permanent it will eventually lead to expired signatures in your zone. Note that if the key files are missing or inaccessible during *named* startup, BIND 9 will try to generate new keys according to the DNSSEC policy, because it has no cached information about existing keys yet.

The *dnssec-policy* statement requires dynamic DNS to be set up, or *inline-signing* to be enabled.

If *inline-signing* is enabled, this means that a signed version of the zone is maintained separately and is written out to a different file on disk (the zone's filename plus a *.signed* extension).

If the zone is dynamic because it is configured with an *update-policy* or *allow-update*, the DNSSEC records are written to the filename set in the original zone's *file*, unless *inline-signing* is explicitly set.

Key rollover timing is computed for each key according to the key lifetime defined in the KASP. The lifetime may be modified by zone TTLs and propagation delays, to prevent validation failures. When a key reaches the end of its lifetime, *named* generates and publishes a new key automatically, then deactivates the old key and activates the new one; finally, the old key is retired according to a computed schedule.

Zone-signing key (ZSK) rollovers require no operator input. Key-signing key (KSK) and combined-signing key (CSK) rollovers require action to be taken to submit a DS record to the parent. Rollover timing for KSKs and CSKs is adjusted to take into account delays in processing and propagating DS updates.

The policy *default* causes the zone to be signed with a single combined-signing key (CSK) using the algorithm ECD-SAP256SHA256; this key has an unlimited lifetime. This policy can be displayed using the command *named -C*.

### Note

The default signing policy may change in future releases. This could require changes to a signing policy when upgrading to a new version of BIND. Check the release notes carefully when upgrading to be informed of such changes. To prevent policy changes on upgrade, use an explicitly defined *dnssec-policy*, rather than *default*.

If a *dnssec-policy* statement is modified and the server restarted or reconfigured, *named* attempts to change the policy smoothly from the old one to the new. For example, if the key algorithm is changed, then a new key is generated with the new algorithm, and the old algorithm is retired when the existing key's lifetime ends.

**Note**

Rolling to a new policy while another key rollover is already in progress is not yet supported, and may result in unexpected behavior.

The following options can be specified in a *dnssec-policy* statement:

**dnskey-ttl**

**Grammar:** dnskey-ttl <duration>;

**Blocks:** dnssec-policy

**Tags:** dnssec

Specifies the time to live (TTL) for DNSKEY resource records.

This indicates the TTL to use when generating DNSKEY resource records. The default is 1 hour (3600 seconds).

**keys**

This is a list specifying the algorithms and roles to use when generating keys and signing the zone. Entries in this list do not represent specific DNSSEC keys, which may be changed on a regular basis, but the roles that keys play in the signing policy. For example, configuring a KSK of algorithm RSASHA256 ensures that the DNSKEY RRset always includes a key-signing key for that algorithm.

Here is an example (for illustration purposes only) of some possible entries in a *keys* list:

```
keys {
    ksk key-directory lifetime unlimited algorithm rsasha256 2048;
    zsk lifetime 30d algorithm 8;
    csk lifetime P6MT12H3M15S algorithm ecdsa256;
};
```

This example specifies that three keys should be used in the zone. The first token determines which role the key plays in signing RRsets. If set to *ksk*, then this is a key-signing key; it has the KSK flag set and is only used to sign DNSKEY, CDS, and CDNSKEY RRsets. If set to *zsk*, this is a zone-signing key; the KSK flag is unset, and the key signs all RRsets *except* DNSKEY, CDS, and CDNSKEY. If set to *csk*, the key has the KSK flag set and is used to sign all RRsets.

An optional second token determines where the key is stored. Currently, keys can only be stored in the configured *key-directory*. This token may be used in the future to store keys in hardware security modules or separate directories.

The *lifetime* parameter specifies how long a key may be used before rolling over. For convenience, TTL-style time-unit suffixes can be used to specify the key lifetime. It also accepts ISO 8601 duration formats.

In the example above, the first key has an unlimited lifetime, the second key may be used for 30 days, and the third key has a rather peculiar lifetime of 6 months, 12 hours, 3 minutes, and 15 seconds. A lifetime of 0 seconds is the same as *unlimited*.

Note that the lifetime of a key may be extended if retiring it too soon would cause validation failures. The key lifetime must be longer than the time it takes to do a rollover; that is, the lifetime must be more than the publication interval (which is the sum of *dnskey-ttl*, *publish-safety*, and *zone-propagation-delay*). It must also be more than the retire interval (which is the sum of *max-zone-ttl*, *retire-safety*, *zone-propagation-delay*, and signing delay (*signatures-validity* minus *signatures-refresh*) for

ZSKs, and the sum of *parent-ds-ttl*, *retire-safety*, and *parent-propagation-delay* for KSKs and CSKs). BIND 9 treats a key lifetime that is too short as an error.

The *algorithm* parameter specifies the key's algorithm, expressed either as a string ("rsasha256", "ecdsa384", etc.) or as a decimal number. An optional second parameter specifies the key's size in bits. If it is omitted, as shown in the example for the second and third keys, an appropriate default size for the algorithm is used. Each KSK/ZSK pair must have the same algorithm. A CSK combines the functionality of a ZSK and a KSK.

#### **purge-keys**

**Grammar:** `purge-keys <duration>;`

**Blocks:** dnssec-policy

**Tags:** dnssec

Specifies the amount of time after which DNSSEC keys that have been deleted from the zone can be removed from disk.

This is the amount of time after which DNSSEC keys that have been deleted from the zone can be removed from disk. If a key still determined to have presence (for example in some resolver cache), *named* will not remove the key files.

The default is P90D (90 days). Set this option to 0 to never purge deleted keys.

#### **publish-safety**

**Grammar:** `publish-safety <duration>;`

**Blocks:** dnssec-policy

**Tags:** dnssec

Increases the amount of time between when keys are published and when they become active, to allow for unforeseen events.

This is a margin that is added to the pre-publication interval in rollover timing calculations, to give some extra time to cover unforeseen events. This increases the time between when keys are published and when they become active. The default is PT1H (1 hour).

#### **retire-safety**

**Grammar:** `retire-safety <duration>;`

**Blocks:** dnssec-policy

**Tags:** dnssec

Increases the amount of time a key remains published after it is no longer active, to allow for unforeseen events.

This is a margin that is added to the post-publication interval in rollover timing calculations, to give some extra time to cover unforeseen events. This increases the time a key remains published after it is no longer active. The default is PT1H (1 hour).

**signatures-jitter**

**Grammar:** `signatures-jitter <duration>;`

**Blocks:** dnssec-policy

**Tags:** dnssec

Specifies a range for signature expirations.

To prevent all signatures from expiring at the same moment, BIND 9 may vary the validity interval of individual signatures. The validity of a newly generated signature is in the range between *signatures-validity* (maximum) and *signatures-validity*, minus *signatures-jitter* (minimum). The default jitter is 12 hours, and the configured value must be lower than both *signatures-validity* and *signatures-validity-dnskey*.

**signatures-refresh**

**Grammar:** `signatures-refresh <duration>;`

**Blocks:** dnssec-policy

**Tags:** dnssec

Specifies how frequently an RRSIG record is refreshed.

This determines how frequently an RRSIG record needs to be refreshed. The signature is renewed when the time until the expiration time is less than the specified interval. The default is P5D (5 days), meaning signatures that expire in 5 days or sooner are refreshed. The *signatures-refresh* value must be less than 90% of the minimum value of *signatures-validity* and *signatures-validity-dnskey*.

**signatures-validity**

**Grammar:** `signatures-validity <duration>;`

**Blocks:** dnssec-policy

**Tags:** dnssec

Indicates the validity period of an RRSIG record.

This indicates the validity period of an RRSIG record (subject to inception offset and jitter). The default is P2W (2 weeks).

**signatures-validity-dnskey**

**Grammar:** `signatures-validity-dnskey <duration>;`

**Blocks:** dnssec-policy

**Tags:** dnssec

Indicates the validity period of DNSKEY records.

This is similar to *signatures-validity*, but for DNSKEY records. The default is P2W (2 weeks).

**max-zone-ttl**

**Grammar dnssec-policy:** `max-zone-ttl <duration>;`

**Grammar options, view, zone (primary, redirect):** `max-zone-ttl ( unlimited | <duration> );`

**Blocks:** dnssec-policy, options, view, zone (primary, redirect)

**Tags:** zone, query

Specifies a maximum permissible time-to-live (TTL) value, in seconds.

This specifies the maximum permissible TTL value for the zone. When a zone file is loaded, any record encountered with a TTL higher than `max-zone-ttl` causes the zone to be rejected.

This ensures that when rolling to a new DNSKEY, the old key will remain available until RRSIG records have expired from caches. The `max-zone-ttl` option guarantees that the largest TTL in the zone is no higher than a known and predictable value.

The default value PT24H (24 hours). A value of zero is treated as if the default value were in use.

**nsec3param**

**Grammar:** `nsec3param [ iterations <integer> ] [ optout <boolean> ] [ salt-length <integer> ];`

**Blocks:** dnssec-policy

**Tags:** dnssec

Specifies the use of NSEC3 instead of NSEC, and sets NSEC3 parameters.

Use NSEC3 instead of NSEC, and optionally set the NSEC3 parameters.

Here is an example of an `nsec3` configuration:

```
nsec3param iterations 0 optout no salt-length 0;
```

The default is to use *NSEC*. The `iterations`, `optout`, and `salt-length` parts are optional, but if not set, the values in the example above are the default *NSEC3* parameters. Note that the specific salt string is not specified by the user; `named` creates a salt of the indicated length.

 **Warning**

Do not use extra `iterations`, `salt`, and `opt-out` unless their implications are fully understood. A higher number of iterations causes interoperability problems and opens servers to CPU-exhausting DoS attacks. See [RFC 9276](#).

**zone-propagation-delay**

**Grammar:** `zone-propagation-delay <duration>;`

**Blocks:** dnssec-policy

**Tags:** dnssec, zone

Sets the propagation delay from the time a zone is first updated to when the new version of the zone is served by all secondary servers.

This is the expected propagation delay from the time when a zone is first updated to the time when the new version of the zone is served by all secondary servers. The default is `PT5M` (5 minutes).

**parent-ds-ttl**

**Grammar:** `parent-ds-ttl <duration>;`

**Blocks:** `dnssec-policy`

**Tags:** `dnssec`

Sets the time to live (TTL) of the DS RRset used by the parent zone.

This is the TTL of the DS RRset that the parent zone uses. The default is `P1D` (1 day).

**parent-propagation-delay**

**Grammar:** `parent-propagation-delay <duration>;`

**Blocks:** `dnssec-policy`

**Tags:** `dnssec, zone`

Sets the propagation delay from the time the parent zone is updated to when the new version is served by all of the parent zone's name servers.

This is the expected propagation delay from the time when the parent zone is updated to the time when the new version is served by all of the parent zone's name servers. The default is `PT1H` (1 hour).

**Automated KSK Rollovers**

BIND has mechanisms in place to facilitate automated KSK rollovers. It publishes `CDS` and `CDNSKEY` records that can be used by the parent zone to publish or withdraw the zone's DS records. BIND will query the parental agents to see if the new DS is actually published before withdrawing the old DNSSEC key.

**Note**

The DS response is not validated so it is recommended to set up a trust relationship with the parental agent. For example, use TSIG to authenticate the parental agent, or point to a validating resolver.

The following options apply to DS queries sent to *parental-agents*:

**parental-source**

**Grammar:** `parental-source ( <ipv4_address> | * );`

**Blocks:** `options, view, zone (primary, secondary)`

**Tags:** `dnssec`

Specifies which local IPv4 source address is used to send parental DS queries.

*parental-source* determines which local source address, and optionally UDP port, is used to send parental DS queries. This statement sets the *parental-source* for all zones, but can be overridden on a per-zone or per-view basis by including a *parental-source* statement within the *zone* or *view* block in the configuration file.

**Note**

`port` configuration is deprecated. A warning will be logged when this parameter is used.

**Warning**

Specifying a single port is discouraged, as it removes a layer of protection against spoofing errors.

**Warning**

The configured *port* must not be the same as the listening port.

**parental-source-v6**

**Grammar:** `parental-source-v6 ( <ipv6_address> | * );`

**Blocks:** options, view, zone (primary, secondary)

**Tags:** dnssec

Specifies which local IPv6 source address is used to send parental DS queries.

This option acts like *parental-source*, but applies to parental DS queries sent to IPv6 addresses.

**8.2.27 *managed-keys* Block Grammar****managed-keys****Warning**

This option is deprecated and will be removed in a future version of BIND.

**Grammar:** `managed-keys { <string> ( static-key | initial-key | static-ds | initial-ds ) <integer> <integer> <integer> <quoted_string>; ... }; // may occur multiple times, deprecated`

**Blocks:** topmost, view

**Tags:** deprecated

Deprecated, use *trust-anchors*.

**8.2.28 *managed-keys* Block Definition and Usage**

The *managed-keys* statement has been deprecated in favor of *trust-anchors* with the `initial-key` keyword.

## 8.2.29 *trusted-keys* Block Grammar

**trusted-keys**

### Warning

This option is deprecated and will be removed in a future version of BIND.

**Grammar:** `trusted-keys { <string> <integer> <integer> <integer> <quoted_string>; ... }; // may occur multiple times, deprecated`

**Blocks:** `topmost`, `view`

**Tags:** deprecated

Deprecated, use *trust-anchors*.

## 8.2.30 *trusted-keys* Block Definition and Usage

The *trusted-keys* statement has been deprecated in favor of *trust-anchors* with the `static-key` keyword.

## 8.2.31 *view* Block Grammar

**view**

**Grammar:**

```
view <string> [ <class> ] {
    allow-new-zones <boolean>;
    allow-notify { <address_match_element>; ... };
    allow-query { <address_match_element>; ... };
    allow-query-cache { <address_match_element>; ... };
    allow-query-cache-on { <address_match_element>; ... };
    allow-query-on { <address_match_element>; ... };
    allow-recursion { <address_match_element>; ... };
    allow-recursion-on { <address_match_element>; ... };
    allow-transfer [ port <integer> ] [ transport <string> ] { <address_match_
    ↪element>; ... };
    allow-update { <address_match_element>; ... };
    allow-update-forwarding { <address_match_element>; ... };
    also-notify [ port <integer> ] { ( <remote-servers> | <ipv4_address> [ _
    ↪port <integer> ] | <ipv6_address> [ port <integer> ] ) [ key <string> ] [ tls
    ↪<string> ]; ... };
    alt-transfer-source ( <ipv4_address> | * ); // deprecated
    alt-transfer-source-v6 ( <ipv6_address> | * ); // deprecated
    attach-cache <string>;
    auth-nxdomain <boolean>;
    auto-dnssec ( allow | maintain | off ); // deprecated
    catalog-zones { zone <string> [ default-primaries [ port <integer> ] { (
    ↪<remote-servers> | <ipv4_address> [ port <integer> ] | <ipv6_address> [ port
    ↪<integer> ] ) [ key <string> ] [ tls <string> ]; ... } ] [ zone-directory
    ↪<quoted_string> ] [ in-memory <boolean> ] [ min-update-interval <duration> ]; ..
    ↪. };
```

(continues on next page)

(continued from previous page)

```

check-dup-records ( fail | warn | ignore );
check-integrity <boolean>;
check-mx ( fail | warn | ignore );
check-mx-cname ( fail | warn | ignore );
check-names ( primary | master | secondary | slave | response ) ( fail | ↵
↵warn | ignore ); // may occur multiple times
check-sibling <boolean>;
check-spf ( warn | ignore );
check-srv-cname ( fail | warn | ignore );
check-wildcard <boolean>;
clients-per-query <integer>;
deny-answer-addresses { <address_match_element>; ... } [ except-from {
↵<string>; ... } ];
deny-answer-aliases { <string>; ... } [ except-from { <string>; ... } ];
dialup ( notify | notify-passive | passive | refresh | <boolean> ); // ↵
↵deprecated
disable-algorithms <string> { <string>; ... }; // may occur multiple times
disable-ds-digests <string> { <string>; ... }; // may occur multiple times
disable-empty-zone <string>; // may occur multiple times
dlz <string> {
    database <string>;
    search <boolean>;
}; // may occur multiple times
dns64 <netprefix> {
    break-dnssec <boolean>;
    clients { <address_match_element>; ... };
    exclude { <address_match_element>; ... };
    mapped { <address_match_element>; ... };
    recursive-only <boolean>;
    suffix <ipv6_address>;
}; // may occur multiple times
dns64-contact <string>;
dns64-server <string>;
dnskey-sig-validity <integer>;
dnssrps-enable <boolean>;
dnssrps-options { <unspecified-text> };
dnssec-accept-expired <boolean>;
dnssec-dnskey-kskonly <boolean>;
dnssec-loadkeys-interval <integer>;
dnssec-must-be-secure <string> <boolean>; // may occur multiple times, ↵
↵deprecated
dnssec-policy <string>;
dnssec-secure-to-insecure <boolean>;
dnssec-update-mode ( maintain | no-resign );
dnssec-validation ( yes | no | auto );
dnstap { ( all | auth | client | forwarder | resolver | update ) [ ( ↵
↵query | response ) ]; ... };
dual-stack-servers [ port <integer> ] { ( <quoted_string> [ port <integer>
↵ ] | <ipv4_address> [ port <integer> ] | <ipv6_address> [ port <integer> ] ); ..
↵. };
dyndb <string> <quoted_string> { <unspecified-text> }; // may occur ↵
↵multiple times

```

(continues on next page)

(continued from previous page)

```

edns-udp-size <integer>;
empty-contact <string>;
empty-server <string>;
empty-zones-enable <boolean>;
fetch-quota-params <integer> <fixedpoint> <fixedpoint> <fixedpoint>;
fetches-per-server <integer> [ ( drop | fail ) ];
fetches-per-zone <integer> [ ( drop | fail ) ];
forward ( first | only );
forwarders [ port <integer> ] { ( <ipv4_address> | <ipv6_address> ) [
↳port <integer> ]; ... };
glue-cache <boolean>; // deprecated
ipv4only-contact <string>;
ipv4only-enable <boolean>;
ipv4only-server <string>;
ixfr-from-differences ( primary | master | secondary | slave | <boolean>
↳);
key <string> {
    algorithm <string>;
    secret <string>;
}; // may occur multiple times
key-directory <quoted_string>;
lame-ttl <duration>;
lmbd-mapsize <sizeval>;
managed-keys { <string> ( static-key | initial-key | static-ds | initial-
↳ds ) <integer> <integer> <integer> <quoted_string>; ... }; // may occur
↳multiple times, deprecated
masterfile-format ( raw | text );
masterfile-style ( full | relative );
match-clients { <address_match_element>; ... };
match-destinations { <address_match_element>; ... };
match-recursive-only <boolean>;
max-cache-size ( default | unlimited | <sizeval> | <percentage> );
max-cache-ttl <duration>;
max-clients-per-query <integer>;
max-ixfr-ratio ( unlimited | <percentage> );
max-journal-size ( default | unlimited | <sizeval> );
max-ncache-ttl <duration>;
max-query-count <integer>;
max-query-restarts <integer>;
max-records <integer>;
max-records-per-type <integer>;
max-recursion-depth <integer>;
max-recursion-queries <integer>;
max-refresh-time <integer>;
max-retry-time <integer>;
max-stale-ttl <duration>;
max-transfer-idle-in <integer>;
max-transfer-idle-out <integer>;
max-transfer-time-in <integer>;
max-transfer-time-out <integer>;
max-types-per-name <integer>;
max-udp-size <integer>;

```

(continues on next page)

(continued from previous page)

```

max-zone-ttl ( unlimited | <duration> );
message-compression <boolean>;
min-cache-ttl <duration>;
min-ncache-ttl <duration>;
min-refresh-time <integer>;
min-retry-time <integer>;
minimal-any <boolean>;
minimal-responses ( no-auth | no-auth-recursive | <boolean> );
multi-master <boolean>;
new-zones-directory <quoted_string>;
no-case-compress { <address_match_element>; ... };
nocookie-udp-size <integer>;
notify ( explicit | master-only | primary-only | <boolean> );
notify-delay <integer>;
notify-source ( <ipv4_address> | * );
notify-source-v6 ( <ipv6_address> | * );
notify-to-soa <boolean>;
nsec3-test-zone <boolean>; // test only
nta-lifetime <duration>;
nta-recheck <duration>;
nxdomain-redirect <string>;
parental-source ( <ipv4_address> | * );
parental-source-v6 ( <ipv6_address> | * );
plugin ( query ) <string> [ { <unspecified-text> } ]; // may occur
↳multiple times
preferred-glue <string>;
prefetch <integer> [ <integer> ];
provide-ixfr <boolean>;
qname-minimization ( strict | relaxed | disabled | off );
query-source [ address ] ( <ipv4_address> | * );
query-source-v6 [ address ] ( <ipv6_address> | * );
rate-limit {
    all-per-second <integer>;
    errors-per-second <integer>;
    exempt-clients { <address_match_element>; ... };
    ipv4-prefix-length <integer>;
    ipv6-prefix-length <integer>;
    log-only <boolean>;
    max-table-size <integer>;
    min-table-size <integer>;
    nodata-per-second <integer>;
    nxdomains-per-second <integer>;
    qps-scale <integer>;
    referrals-per-second <integer>;
    responses-per-second <integer>;
    slip <integer>;
    window <integer>;
};
recursion <boolean>;
request-expire <boolean>;
request-ixfr <boolean>;
request-nsid <boolean>;

```

(continues on next page)

(continued from previous page)

```

require-server-cookie <boolean>;
resolver-nonbackoff-tries <integer>; // deprecated
resolver-query-timeout <integer>;
resolver-retry-interval <integer>; // deprecated
response-padding { <address_match_element>; ... } block-size <integer>;
response-policy { zone <string> [ add-soa <boolean> ] [ log <boolean> ] [
↳max-policy-ttl <duration> ] [ min-update-interval <duration> ] [ policy ( cname_
↳| disabled | drop | given | no-op | nxdomain | passthru | tcp-only
↳<quoted_string> ) ] [ recursive-only <boolean> ] [ nsip-enable <boolean> ] [
↳nsdname-enable <boolean> ]; ... } [ add-soa <boolean> ] [ break-dnssec <boolean>
↳ ] [ max-policy-ttl <duration> ] [ min-update-interval <duration> ] [ min-ns-
↳dots <integer> ] [ nsip-wait-recurse <boolean> ] [ nsdname-wait-recurse
↳<boolean> ] [ qname-wait-recurse <boolean> ] [ recursive-only <boolean> ] [
↳nsip-enable <boolean> ] [ nsdname-enable <boolean> ] [ dnsrps-enable <boolean>
↳] [ dnsrps-options { <unspecified-text> } ];
    root-delegation-only [ exclude { <string>; ... } ]; // deprecated
    root-key-sentinel <boolean>;
    rrsset-order { [ class <string> ] [ type <string> ] [ name <quoted_string>
↳] <string> <string>; ... };
    send-cookie <boolean>;
    serial-update-method ( date | increment | unixtime );
    server <netprefix> {
        bogus <boolean>;
        edns <boolean>;
        edns-udp-size <integer>;
        edns-version <integer>;
        keys <server_key>;
        max-udp-size <integer>;
        notify-source ( <ipv4_address> | * );
        notify-source-v6 ( <ipv6_address> | * );
        padding <integer>;
        provide-ixfr <boolean>;
        query-source [ address ] ( <ipv4_address> | * );
        query-source-v6 [ address ] ( <ipv6_address> | * );
        request-expire <boolean>;
        request-ixfr <boolean>;
        request-nsid <boolean>;
        send-cookie <boolean>;
        tcp-keepalive <boolean>;
        tcp-only <boolean>;
        transfer-format ( many-answers | one-answer );
        transfer-source ( <ipv4_address> | * );
        transfer-source-v6 ( <ipv6_address> | * );
        transfers <integer>;
    }; // may occur multiple times
    servfail-ttl <duration>;
    sig-signing-nodes <integer>;
    sig-signing-signatures <integer>;
    sig-signing-type <integer>;
    sig-validity-interval <integer> [ <integer> ];
    sortlist { <address_match_element>; ... };
    stale-answer-client-timeout ( disabled | off | <integer> );

```

(continues on next page)

(continued from previous page)

```

stale-answer-enable <boolean>;
stale-answer-ttl <duration>;
stale-cache-enable <boolean>;
stale-refresh-time <duration>;
suppress-initial-notify <boolean>; // obsolete
synth-from-dnssec <boolean>;
transfer-format ( many-answers | one-answer );
transfer-source ( <ipv4_address> | * );
transfer-source-v6 ( <ipv6_address> | * );
trust-anchor-telemetry <boolean>;
trust-anchors { <string> ( static-key | initial-key | static-ds | initial-
↳ds ) <integer> <integer> <integer> <quoted_string>; ... }; // may occur
↳multiple times
    trusted-keys { <string> <integer> <integer> <integer> <quoted_string>; ...
↳ }; // may occur multiple times, deprecated
try-tcp-refresh <boolean>;
update-check-ksk <boolean>;
use-alt-transfer-source <boolean>; // deprecated
v6-bias <integer>;
validate-except { <string>; ... };
zero-no-soa-ttl <boolean>;
zero-no-soa-ttl-cache <boolean>;
    zone <string> [ <class> ] {
        in-view <string>;
    };
    zone <string> [ <class> ] {
        type delegation-only;
    };
    zone <string> [ <class> ] {
        type forward;
        delegation-only <boolean>; // deprecated
        forward ( first | only );
        forwarders [ port <integer> ] { ( <ipv4_address> | <ipv6_address>
↳ ) [ port <integer> ]; ... };
    };
    zone <string> [ <class> ] {
        type hint;
        check-names ( fail | warn | ignore );
        delegation-only <boolean>; // deprecated
        file <quoted_string>;
    };
    zone <string> [ <class> ] {
        type mirror;
        allow-notify { <address_match_element>; ... };
        allow-query { <address_match_element>; ... };
        allow-query-on { <address_match_element>; ... };
        allow-transfer [ port <integer> ] [ transport <string> ] {
↳<address_match_element>; ... };
        allow-update-forwarding { <address_match_element>; ... };
        also-notify [ port <integer> ] { ( <remote-servers> | <ipv4_
↳address> [ port <integer> ] | <ipv6_address> [ port <integer> ] ) [ key <string>
↳ ] [ tls <string> ]; ... };

```

(continues on next page)

(continued from previous page)

```

alt-transfer-source ( <ipv4_address> | * ); // deprecated
alt-transfer-source-v6 ( <ipv6_address> | * ); // deprecated
check-names ( fail | warn | ignore );
database <string>;
file <quoted_string>;
ixfr-from-differences <boolean>;
journal <quoted_string>;
masterfile-format ( raw | text );
masterfile-style ( full | relative );
max-ixfr-ratio ( unlimited | <percentage> );
max-journal-size ( default | unlimited | <sizeval> );
max-records <integer>;
max-records-per-type <integer>;
max-refresh-time <integer>;
max-retry-time <integer>;
max-transfer-idle-in <integer>;
max-transfer-idle-out <integer>;
max-transfer-time-in <integer>;
max-transfer-time-out <integer>;
max-types-per-name <integer>;
min-refresh-time <integer>;
min-retry-time <integer>;
multi-master <boolean>;
notify ( explicit | master-only | primary-only | <boolean> );
notify-delay <integer>;
notify-source ( <ipv4_address> | * );
notify-source-v6 ( <ipv6_address> | * );
primaries [ port <integer> ] { ( <remote-servers> | <ipv4_
↪address> [ port <integer> ] | <ipv6_address> [ port <integer> ] ) [ key <string>
↪ ] [ tls <string> ]; ... };
request-expire <boolean>;
request-ixfr <boolean>;
transfer-source ( <ipv4_address> | * );
transfer-source-v6 ( <ipv6_address> | * );
try-tcp-refresh <boolean>;
use-alt-transfer-source <boolean>; // deprecated
zero-no-soa-ttl <boolean>;
zone-statistics ( full | terse | none | <boolean> );
};
zone <string> [ <class> ] {
    type primary;
    allow-query { <address_match_element>; ... };
    allow-query-on { <address_match_element>; ... };
    allow-transfer [ port <integer> ] [ transport <string> ] {
↪<address_match_element>; ... };
    allow-update { <address_match_element>; ... };
    also-notify [ port <integer> ] { ( <remote-servers> | <ipv4_
↪address> [ port <integer> ] | <ipv6_address> [ port <integer> ] ) [ key <string>
↪ ] [ tls <string> ]; ... };
    alt-transfer-source ( <ipv4_address> | * ); // deprecated
    alt-transfer-source-v6 ( <ipv6_address> | * ); // deprecated
    auto-dnssec ( allow | maintain | off ); // deprecated

```

(continues on next page)

(continued from previous page)

```

check-dup-records ( fail | warn | ignore );
check-integrity <boolean>;
check-mx ( fail | warn | ignore );
check-mx-cname ( fail | warn | ignore );
check-names ( fail | warn | ignore );
check-sibling <boolean>;
check-spf ( warn | ignore );
check-srv-cname ( fail | warn | ignore );
check-wildcard <boolean>;
database <string>;
dialup ( notify | notify-passive | passive | refresh | <boolean>_
↳); // deprecated
dlz <string>;
dnskey-sig-validity <integer>;
dnssec-dnskey-kskonly <boolean>;
dnssec-loadkeys-interval <integer>;
dnssec-policy <string>;
dnssec-secure-to-insecure <boolean>;
dnssec-update-mode ( maintain | no-resign );
file <quoted_string>;
forward ( first | only );
forwarders [ port <integer> ] { ( <ipv4_address> | <ipv6_address>
↳ ) [ port <integer> ]; ... };
inline-signing <boolean>;
ixfr-from-differences <boolean>;
journal <quoted_string>;
key-directory <quoted_string>;
masterfile-format ( raw | text );
masterfile-style ( full | relative );
max-ixfr-ratio ( unlimited | <percentage> );
max-journal-size ( default | unlimited | <sizeval> );
max-records <integer>;
max-records-per-type <integer>;
max-transfer-idle-out <integer>;
max-transfer-time-out <integer>;
max-types-per-name <integer>;
max-zone-ttl ( unlimited | <duration> );
notify ( explicit | master-only | primary-only | <boolean> );
notify-delay <integer>;
notify-source ( <ipv4_address> | * );
notify-source-v6 ( <ipv6_address> | * );
notify-to-soa <boolean>;
nsec3-test-zone <boolean>; // test only
parental-agents [ port <integer> ] { ( <remote-servers> | <ipv4_
↳address> [ port <integer> ] | <ipv6_address> [ port <integer> ] ) [ key <string>
↳ ] [ tls <string> ]; ... };
parental-source ( <ipv4_address> | * );
parental-source-v6 ( <ipv6_address> | * );
serial-update-method ( date | increment | unixtime );
sig-signing-nodes <integer>;
sig-signing-signatures <integer>;
sig-signing-type <integer>;

```

(continues on next page)

(continued from previous page)

```

        sig-validity-interval <integer> [ <integer> ];
        update-check-ksk <boolean>;
        update-policy ( local | { ( deny | grant ) <string> ( 6to4-self |
↪external | krb5-self | krb5-selfsub | krb5-subdomain | krb5-subdomain-self-rhs |
↪ms-self | ms-selfsub | ms-subdomain | ms-subdomain-self-rhs | name | self |
↪selfsub | selfwild | subdomain | tcp-self | wildcard | zonesub ) [ <string> ]
↪<rrtpeplist>; ... } );
        zero-no-soa-ttl <boolean>;
        zone-statistics ( full | terse | none | <boolean> );
    };
    zone <string> [ <class> ] {
        type redirect;
        allow-query { <address_match_element>; ... };
        allow-query-on { <address_match_element>; ... };
        dlz <string>;
        file <quoted_string>;
        masterfile-format ( raw | text );
        masterfile-style ( full | relative );
        max-records <integer>;
        max-records-per-type <integer>;
        max-types-per-name <integer>;
        max-zone-ttl ( unlimited | <duration> );
        primaries [ port <integer> ] { ( <remote-servers> | <ipv4_
↪address> [ port <integer> ] | <ipv6_address> [ port <integer> ] ) [ key <string>
↪ ] [ tls <string> ]; ... };
        zone-statistics ( full | terse | none | <boolean> );
    };
    zone <string> [ <class> ] {
        type secondary;
        allow-notify { <address_match_element>; ... };
        allow-query { <address_match_element>; ... };
        allow-query-on { <address_match_element>; ... };
        allow-transfer [ port <integer> ] [ transport <string> ] {
↪<address_match_element>; ... };
        allow-update-forwarding { <address_match_element>; ... };
        also-notify [ port <integer> ] { ( <remote-servers> | <ipv4_
↪address> [ port <integer> ] | <ipv6_address> [ port <integer> ] ) [ key <string>
↪ ] [ tls <string> ]; ... };
        alt-transfer-source ( <ipv4_address> | * ); // deprecated
        alt-transfer-source-v6 ( <ipv6_address> | * ); // deprecated
        auto-dnssec ( allow | maintain | off ); // deprecated
        check-names ( fail | warn | ignore );
        database <string>;
        dialup ( notify | notify-passive | passive | refresh | <boolean> |
↪); // deprecated
        dlz <string>;
        dnskey-sig-validity <integer>;
        dnssec-dnskey-kskonly <boolean>;
        dnssec-loadkeys-interval <integer>;
        dnssec-policy <string>;
        dnssec-update-mode ( maintain | no-resign );
        file <quoted_string>;

```

(continues on next page)

(continued from previous page)

```

        forward ( first | only );
        forwarders [ port <integer> ] { ( <ipv4_address> | <ipv6_address>
→ ) [ port <integer> ]; ... };
        inline-signing <boolean>;
        ixfr-from-differences <boolean>;
        journal <quoted_string>;
        key-directory <quoted_string>;
        masterfile-format ( raw | text );
        masterfile-style ( full | relative );
        max-ixfr-ratio ( unlimited | <percentage> );
        max-journal-size ( default | unlimited | <sizeval> );
        max-records <integer>;
        max-records-per-type <integer>;
        max-refresh-time <integer>;
        max-retry-time <integer>;
        max-transfer-idle-in <integer>;
        max-transfer-idle-out <integer>;
        max-transfer-time-in <integer>;
        max-transfer-time-out <integer>;
        max-types-per-name <integer>;
        min-refresh-time <integer>;
        min-retry-time <integer>;
        multi-master <boolean>;
        notify ( explicit | master-only | primary-only | <boolean> );
        notify-delay <integer>;
        notify-source ( <ipv4_address> | * );
        notify-source-v6 ( <ipv6_address> | * );
        notify-to-soa <boolean>;
        nsec3-test-zone <boolean>; // test only
        parental-agents [ port <integer> ] { ( <remote-servers> | <ipv4_
→address> [ port <integer> ] | <ipv6_address> [ port <integer> ] ) [ key <string>
→ ] [ tls <string> ]; ... };
        parental-source ( <ipv4_address> | * );
        parental-source-v6 ( <ipv6_address> | * );
        primaries [ port <integer> ] { ( <remote-servers> | <ipv4_
→address> [ port <integer> ] | <ipv6_address> [ port <integer> ] ) [ key <string>
→ ] [ tls <string> ]; ... };
        request-expire <boolean>;
        request-ixfr <boolean>;
        sig-signing-nodes <integer>;
        sig-signing-signatures <integer>;
        sig-signing-type <integer>;
        sig-validity-interval <integer> [ <integer> ];
        transfer-source ( <ipv4_address> | * );
        transfer-source-v6 ( <ipv6_address> | * );
        try-tcp-refresh <boolean>;
        update-check-ksk <boolean>;
        use-alt-transfer-source <boolean>; // deprecated
        zero-no-soa-ttl <boolean>;
        zone-statistics ( full | terse | none | <boolean> );
    };
    zone <string> [ <class> ] {

```

(continues on next page)

(continued from previous page)

```

        type static-stub;
        allow-query { <address_match_element>; ... };
        allow-query-on { <address_match_element>; ... };
        forward ( first | only );
        forwarders [ port <integer> ] { ( <ipv4_address> | <ipv6_address>
→ ) [ port <integer> ]; ... };
        max-records <integer>;
        max-records-per-type <integer>;
        max-types-per-name <integer>;
        server-addresses { ( <ipv4_address> | <ipv6_address> ); ... };
        server-names { <string>; ... };
        zone-statistics ( full | terse | none | <boolean> );
    };
    zone <string> [ <class> ] {
        type stub;
        allow-query { <address_match_element>; ... };
        allow-query-on { <address_match_element>; ... };
        check-names ( fail | warn | ignore );
        database <string>;
        delegation-only <boolean>; // deprecated
        dialup ( notify | notify-passive | passive | refresh | <boolean>
→); // deprecated
        file <quoted_string>;
        forward ( first | only );
        forwarders [ port <integer> ] { ( <ipv4_address> | <ipv6_address>
→ ) [ port <integer> ]; ... };
        masterfile-format ( raw | text );
        masterfile-style ( full | relative );
        max-records <integer>;
        max-records-per-type <integer>;
        max-refresh-time <integer>;
        max-retry-time <integer>;
        max-transfer-idle-in <integer>;
        max-transfer-time-in <integer>;
        max-types-per-name <integer>;
        min-refresh-time <integer>;
        min-retry-time <integer>;
        multi-master <boolean>;
        primaries [ port <integer> ] { ( <remote-servers> | <ipv4_
→address> [ port <integer> ] | <ipv6_address> [ port <integer> ] ) [ key <string>
→ ] [ tls <string> ]; ... };
        transfer-source ( <ipv4_address> | * );
        transfer-source-v6 ( <ipv6_address> | * );
        use-alt-transfer-source <boolean>; // deprecated
        zone-statistics ( full | terse | none | <boolean> );
    };

    zone-statistics ( full | terse | none | <boolean> );
}; // may occur multiple times

```

**Blocks:** topmost**Tags:** view

Allows a name server to answer a DNS query differently depending on who is asking.

```
view view_name [ class ] {
    match-clients { address_match_list } ;
    match-destinations { address_match_list } ;
    match-recursive-only <boolean> ;
    [ view_option ; ... ]
    [ zone_statement ; ... ]
} ;
```

### 8.2.32 *view* Block Definition and Usage

The *view* statement is a powerful feature of BIND 9 that lets a name server answer a DNS query differently depending on who is asking. It is particularly useful for implementing split DNS setups without having to run multiple servers.

#### **match-clients**

**Grammar:** `match-clients { <address_match_element>; ... };`

**Blocks:** `view`

**Tags:** `view`

Specifies a view of DNS namespace for a given subset of client IP addresses.

#### **match-destinations**

**Grammar:** `match-destinations { <address_match_element>; ... };`

**Blocks:** `view`

**Tags:** `view`

Specifies a view of DNS namespace for a given subset of destination IP addresses.

Each *view* statement defines a view of the DNS namespace that is seen by a subset of clients. A client matches a view if its source IP address matches the *address\_match\_list* of the view's *match-clients* clause, and its destination IP address matches the *address\_match\_list* of the view's *match-destinations* clause. If not specified, both *match-clients* and *match-destinations* default to matching all addresses. In addition to checking IP addresses, *match-clients* and *match-destinations* can also take the name of a TSIG *key*, which provides a mechanism for the client to select the view.

#### **match-recursive-only**

**Grammar:** `match-recursive-only <boolean>;`

**Blocks:** `view`

**Tags:** `view`

Specifies that only recursive requests can match this view of the DNS namespace.

A view can also be specified as *match-recursive-only*, which means that only recursive requests from matching clients match that view. The order of the *view* statements is significant; a client request is resolved in the context of the first *view* that it matches.

Zones defined within a *view* statement are only accessible to clients that match the *view*. By defining a zone of the same name in multiple views, different zone data can be given to different clients: for example, "internal" and "external" clients in a split DNS setup.

Many of the options given in the *options* statement can also be used within a *view* statement, and then apply only when resolving queries with that view. When no view-specific value is given, the value in the *options* statement is used as a default. Also, zone options can have default values specified in the *view* statement; these view-specific defaults take precedence over those in the *options* statement.

Views are class-specific. If no class is given, class IN is assumed. Note that all non-IN views must contain a hint zone, since only the IN class has compiled-in default hints.

If there are no *view* statements in the config file, a default view that matches any client is automatically created in class IN. Any *zone* statements specified on the top level of the configuration file are considered to be part of this default view, and the *options* statement applies to the default view. If any explicit *view* statements are present, all *zone* statements must occur inside *view* statements.

Here is an example of a typical split DNS setup implemented using *view* statements:

```
view "internal" {
    // This should match our internal networks.
    match-clients { 10.0.0.0/8; };

    // Provide recursive service to internal
    // clients only.
    recursion yes;

    // Provide a complete view of the example.com
    // zone including addresses of internal hosts.
    zone "example.com" {
        type primary;
        file "example-internal.db";
    };
};

view "external" {
    // Match all clients not matched by the
    // previous view.
    match-clients { any; };

    // Refuse recursive service to external clients.
    recursion no;

    // Provide a restricted view of the example.com
    // zone containing only publicly accessible hosts.
    zone "example.com" {
        type primary;
        file "example-external.db";
    };
};
```

### 8.2.33 *zone* Block Grammar

**zone**

**Blocks:** topmost, view

**Tags:** zone

Specifies the zone in a BIND 9 configuration.

### 8.2.34 *zone* Block Definition and Usage

#### Zone Types

**type**

**Blocks:** zone (delegation-only, forward, hint, mirror, primary, redirect, secondary, static-stub, stub)

**Tags:** zone

Specifies the kind of zone in a given configuration.

The *type* keyword is required for the *zone* configuration unless it is an *in-view* configuration. Its acceptable values are: *primary* (or master), *secondary* (or slave), *mirror*, *hint*, *stub*, *static-stub*, *forward*, *redirect*, or *delegation-only*.

**type primary**

**Grammar:**

```
zone <string> [ <class> ] {
    type primary;
    allow-query { <address_match_element>; ... };
    allow-query-on { <address_match_element>; ... };
    allow-transfer [ port <integer> ] [ transport <string> ] { <address_match_
→element>; ... };
    allow-update { <address_match_element>; ... };
    also-notify [ port <integer> ] { ( <remote-servers> | <ipv4_address> [ _
→port <integer> ] | <ipv6_address> [ port <integer> ] ) [ key <string> ] [ tls
→<string> ]; ... };
    alt-transfer-source ( <ipv4_address> | * ); // deprecated
    alt-transfer-source-v6 ( <ipv6_address> | * ); // deprecated
    auto-dnssec ( allow | maintain | off ); // deprecated
    check-dup-records ( fail | warn | ignore );
    check-integrity <boolean>;
    check-mx ( fail | warn | ignore );
    check-mx-cname ( fail | warn | ignore );
    check-names ( fail | warn | ignore );
    check-sibling <boolean>;
    check-spf ( warn | ignore );
    check-srv-cname ( fail | warn | ignore );
    check-wildcard <boolean>;
    database <string>;
    dialup ( notify | notify-passive | passive | refresh | <boolean> ); //_
→deprecated
    dlz <string>;
```

(continues on next page)

(continued from previous page)

```

dnskey-sig-validity <integer>;
dnssec-dnskey-kskonly <boolean>;
dnssec-loadkeys-interval <integer>;
dnssec-policy <string>;
dnssec-secure-to-insecure <boolean>;
dnssec-update-mode ( maintain | no-resign );
file <quoted_string>;
forward ( first | only );
forwarders [ port <integer> ] { ( <ipv4_address> | <ipv6_address> ) [
↳port <integer> ]; ... };
inline-signing <boolean>;
ixfr-from-differences <boolean>;
journal <quoted_string>;
key-directory <quoted_string>;
masterfile-format ( raw | text );
masterfile-style ( full | relative );
max-ixfr-ratio ( unlimited | <percentage> );
max-journal-size ( default | unlimited | <sizeval> );
max-records <integer>;
max-records-per-type <integer>;
max-transfer-idle-out <integer>;
max-transfer-time-out <integer>;
max-types-per-name <integer>;
max-zone-ttl ( unlimited | <duration> );
notify ( explicit | master-only | primary-only | <boolean> );
notify-delay <integer>;
notify-source ( <ipv4_address> | * );
notify-source-v6 ( <ipv6_address> | * );
notify-to-soa <boolean>;
nsec3-test-zone <boolean>; // test only
parental-agents [ port <integer> ] { ( <remote-servers> | <ipv4_address>↳
↳[ port <integer> ] | <ipv6_address> [ port <integer> ] ) [ key <string> ] [ tls
↳<string> ]; ... };
parental-source ( <ipv4_address> | * );
parental-source-v6 ( <ipv6_address> | * );
serial-update-method ( date | increment | unixtime );
sig-signing-nodes <integer>;
sig-signing-signatures <integer>;
sig-signing-type <integer>;
sig-validity-interval <integer> [ <integer> ];
update-check-ksk <boolean>;
update-policy ( local | { ( deny | grant ) <string> ( 6to4-self |↳
↳external | krb5-self | krb5-selfsub | krb5-subdomain | krb5-subdomain-self-rhs↳
↳| ms-self | ms-selfsub | ms-subdomain | ms-subdomain-self-rhs | name | self |↳
↳selfsub | selfwild | subdomain | tcp-self | wildcard | zonesub ) [ <string> ]
↳<rdatatype>; ... } );
zero-no-soa-ttl <boolean>;
zone-statistics ( full | terse | none | <boolean> );
};

```

**Blocks:** zone, view.zone**Tags:** zone

Contains the main copy of the data for a zone.

A primary zone has a master copy of the data for the zone and is able to provide authoritative answers for it. Type `master` is a synonym for `primary`.

**type secondary**

**Grammar:**

```
zone <string> [ <class> ] {
    type secondary;
    allow-notify { <address_match_element>; ... };
    allow-query { <address_match_element>; ... };
    allow-query-on { <address_match_element>; ... };
    allow-transfer [ port <integer> ] [ transport <string> ] { <address_match_
↳element>; ... };
    allow-update-forwarding { <address_match_element>; ... };
    also-notify [ port <integer> ] { ( <remote-servers> | <ipv4_address> [ _
↳port <integer> ] | <ipv6_address> [ port <integer> ] ) [ key <string> ] [ tls
↳<string> ]; ... };
    alt-transfer-source ( <ipv4_address> | * ); // deprecated
    alt-transfer-source-v6 ( <ipv6_address> | * ); // deprecated
    auto-dnssec ( allow | maintain | off ); // deprecated
    check-names ( fail | warn | ignore );
    database <string>;
    dialup ( notify | notify-passive | passive | refresh | <boolean> ); // _
↳deprecated
    dlz <string>;
    dnskey-sig-validity <integer>;
    dnssec-dnskey-kskonly <boolean>;
    dnssec-loadkeys-interval <integer>;
    dnssec-policy <string>;
    dnssec-update-mode ( maintain | no-resign );
    file <quoted_string>;
    forward ( first | only );
    forwarders [ port <integer> ] { ( <ipv4_address> | <ipv6_address> ) [ _
↳port <integer> ]; ... };
    inline-signing <boolean>;
    ixfr-from-differences <boolean>;
    journal <quoted_string>;
    key-directory <quoted_string>;
    masterfile-format ( raw | text );
    masterfile-style ( full | relative );
    max-ixfr-ratio ( unlimited | <percentage> );
    max-journal-size ( default | unlimited | <sizeval> );
    max-records <integer>;
    max-records-per-type <integer>;
    max-refresh-time <integer>;
    max-retry-time <integer>;
    max-transfer-idle-in <integer>;
    max-transfer-idle-out <integer>;
    max-transfer-time-in <integer>;
    max-transfer-time-out <integer>;
    max-types-per-name <integer>;
```

(continues on next page)

(continued from previous page)

```

min-refresh-time <integer>;
min-retry-time <integer>;
multi-master <boolean>;
notify ( explicit | master-only | primary-only | <boolean> );
notify-delay <integer>;
notify-source ( <ipv4_address> | * );
notify-source-v6 ( <ipv6_address> | * );
notify-to-soa <boolean>;
nsec3-test-zone <boolean>; // test only
parental-agents [ port <integer> ] { ( <remote-servers> | <ipv4_address> |
↳[ port <integer> ] | <ipv6_address> [ port <integer> ] ) [ key <string> ] [ tls
↳<string> ]; ... };
parental-source ( <ipv4_address> | * );
parental-source-v6 ( <ipv6_address> | * );
primaries [ port <integer> ] { ( <remote-servers> | <ipv4_address> [
↳port <integer> ] | <ipv6_address> [ port <integer> ] ) [ key <string> ] [ tls
↳<string> ]; ... };
request-expire <boolean>;
request-ixfr <boolean>;
sig-signing-nodes <integer>;
sig-signing-signatures <integer>;
sig-signing-type <integer>;
sig-validity-interval <integer> [ <integer> ];
transfer-source ( <ipv4_address> | * );
transfer-source-v6 ( <ipv6_address> | * );
try-tcp-refresh <boolean>;
update-check-ksk <boolean>;
use-alt-transfer-source <boolean>; // deprecated
zero-no-soa-ttl <boolean>;
zone-statistics ( full | terse | none | <boolean> );
};

```

**Blocks:** zone, view.zone**Tags:** zone

Contains a duplicate of the data for a zone that has been transferred from a primary server.

A secondary zone is a replica of a primary zone. Type `slave` is a synonym for `secondary`. The `primaries` list specifies one or more IP addresses of primary servers that the secondary contacts to update its copy of the zone.

Primaries list elements can also be names of other primaries lists. By default, transfers are made from port 53 on the servers; this can be changed for all servers by specifying a port number before the list of IP addresses, or on a per-server basis after the IP address. Authentication to the primary can also be done with per-server TSIG keys.

A secondary zone is a replica of a primary zone. Type `slave` is a synonym for `secondary`. The `primaries` list specifies one or more IP addresses of primary servers that the secondary contacts to update its copy of the zone.

A zone may refresh on timer or on receipt of a notify. If a valid notify is received where the notify carries a serial number larger than the one in the SOA currently served, then the secondary will schedule a zone refresh.

A notify is considered valid if the sender is one of the servers in the NS RRset for the zone, has been explicitly allowed using an `allow-notify` clause, or is from an address listed in the primary servers clause.

If no notifies have been received, the server will try to refresh the zone. The REFRESH field in the SOA record

determines how long after the last zone update it should query the primaries for the SOA record. Again, if the SOA record contains a serial number larger than the one in the SOA currently served, a zone refresh is scheduled. If a notify is received while a refresh is in progress, the serial number of the notify is checked and if it is larger, another refresh for the zone is queued. There will at most be one zone refresh queued.

The primary servers are queried in turn, *named* will move on to the next server in the list if either it is unable to get a valid response from the server it is currently querying, or the primary being queried returns the same or smaller SOA than the secondary is currently serving. On the first SOA received that has a serial bigger than the one currently served, *named* will initiate a zone transfer with that server. Once the zone transfer has been received and the zone has been updated, then this zone refresh is complete, and no other servers are tried.

When receiving a notify, *named* does not first query the sender of the notify. It will continue with the next server in the list that transferred the zone, skipping over unreachable servers. A primary is considered unreachable if the secondary cannot get a response from the server. This state will be cached for 10 minutes, or until a notify is received from that address.

Furthermore, a zone is refreshed when the secondary server is restarted, or when a *rndc refresh* command is received.

If a file is specified, then the replica is written to this file whenever the zone is changed, and reloaded from this file on a server restart. Use of a file is recommended, since it often speeds server startup and eliminates a needless waste of bandwidth. Note that for large numbers (in the tens or hundreds of thousands) of zones per server, it is best to use a two-level naming scheme for zone filenames. For example, a secondary server for the zone *example.com* might place the zone contents into a file called *ex/example.com*, where *ex/* is just the first two letters of the zone name. (Most operating systems behave very slowly if there are 100,000 files in a single directory.)

#### type mirror

##### Grammar:

```
zone <string> [ <class> ] {
    type mirror;
    allow-notify { <address_match_element>; ... };
    allow-query { <address_match_element>; ... };
    allow-query-on { <address_match_element>; ... };
    allow-transfer [ port <integer> ] [ transport <string> ] { <address_match_
->element>; ... };
    allow-update-forwarding { <address_match_element>; ... };
    also-notify [ port <integer> ] { ( <remote-servers> | <ipv4_address> [ _
->port <integer> ] | <ipv6_address> [ port <integer> ] ) [ key <string> ] [ tls
-><string> ]; ... };
    alt-transfer-source ( <ipv4_address> | * ); // deprecated
    alt-transfer-source-v6 ( <ipv6_address> | * ); // deprecated
    check-names ( fail | warn | ignore );
    database <string>;
    file <quoted_string>;
    ixfr-from-differences <boolean>;
    journal <quoted_string>;
    masterfile-format ( raw | text );
    masterfile-style ( full | relative );
    max-ixfr-ratio ( unlimited | <percentage> );
    max-journal-size ( default | unlimited | <sizeval> );
    max-records <integer>;
    max-records-per-type <integer>;
    max-refresh-time <integer>;
    max-retry-time <integer>;
    max-transfer-idle-in <integer>;
```

(continues on next page)

(continued from previous page)

```

max-transfer-idle-out <integer>;
max-transfer-time-in <integer>;
max-transfer-time-out <integer>;
max-types-per-name <integer>;
min-refresh-time <integer>;
min-retry-time <integer>;
multi-master <boolean>;
notify ( explicit | master-only | primary-only | <boolean> );
notify-delay <integer>;
notify-source ( <ipv4_address> | * );
notify-source-v6 ( <ipv6_address> | * );
primaries [ port <integer> ] { ( <remote-servers> | <ipv4_address> [ ↵
↵port <integer> ] | <ipv6_address> [ port <integer> ] ) [ key <string> ] [ tls
↵<string> ]; ... };
request-expire <boolean>;
request-ixfr <boolean>;
transfer-source ( <ipv4_address> | * );
transfer-source-v6 ( <ipv6_address> | * );
try-tcp-refresh <boolean>;
use-alt-transfer-source <boolean>; // deprecated
zero-no-soa-ttl <boolean>;
zone-statistics ( full | terse | none | <boolean> );
};

```

**Blocks:** zone, view.zone**Tags:** zone

Contains a DNSSEC-validated duplicate of the main data for a zone.

A mirror zone is similar to a zone of *type secondary*, except its data is subject to DNSSEC validation before being used in answers. Validation is applied to the entire zone during the zone transfer process, and again when the zone file is loaded from disk upon restarting *named*. If validation of a new version of a mirror zone fails, a retransfer is scheduled; in the meantime, the most recent correctly validated version of that zone is used until it either expires or a newer version validates correctly. If no usable zone data is available for a mirror zone, due to either transfer failure or expiration, traditional DNS recursion is used to look up the answers instead. Mirror zones cannot be used in a view that does not have recursion enabled.

Answers coming from a mirror zone look almost exactly like answers from a zone of *type secondary*, with the notable exceptions that the AA bit ("authoritative answer") is not set, and the AD bit ("authenticated data") is.

Mirror zones are intended to be used to set up a fast local copy of the root zone (see [RFC 8806](#)). A default list of primary servers for the IANA root zone is built into *named*, so its mirroring can be enabled using the following configuration:

```

zone "." {
    type mirror;
};

```

Mirror zone validation always happens for the entire zone contents. This ensures that each version of the zone used by the resolver is fully self-consistent with respect to DNSSEC. For incoming mirror zone IXFRs, every revision of the zone contained in the IXFR sequence is validated independently, in the order in which the zone revisions appear on the wire. For this reason, it might be useful to force use of AXFR for mirror zones by setting `request-ixfr no`; for the relevant zone (or view). Other, more efficient zone verification methods may be added in the future.

To make mirror zone contents persist between *named* restarts, use the *file* option.

Mirroring a zone other than root requires an explicit list of primary servers to be provided using the *primaries* option (see *primaries* for details), and a key-signing key (KSK) for the specified zone to be explicitly configured as a trust anchor (see *trust-anchors*).

When configuring NOTIFY for a mirror zone, only *notify no;* and *notify explicit;* can be used at the zone level; any other *notify* setting at the zone level is a configuration error. Using any other *notify* setting at the *options* or *view* level causes that setting to be overridden with *notify explicit;* for the mirror zone. The global default for the *notify* option is *yes*, so mirror zones are by default configured with *notify explicit;*.

Outgoing transfers of mirror zones are disabled by default but may be enabled using *allow-transfer*.

### Note

Use of this zone type with any zone other than the root should be considered *experimental* and may cause performance issues, especially for zones that are large and/or frequently updated.

## type hint

### Grammar:

```
zone <string> [ <class> ] {
    type hint;
    check-names ( fail | warn | ignore );
    delegation-only <boolean>; // deprecated
    file <quoted_string>;
};
```

**Blocks:** zone, view.zone

**Tags:** zone

Contains the initial set of root name servers to be used at BIND 9 startup.

The initial set of root name servers is specified using a hint zone. When the server starts, it uses the root hints to find a root name server and get the most recent list of root name servers. If no hint zone is specified for class IN, the server uses a compiled-in default set of root servers hints. Classes other than IN have no built-in default hints.

## type stub

### Grammar:

```
zone <string> [ <class> ] {
    type stub;
    allow-query { <address_match_element>; ... };
    allow-query-on { <address_match_element>; ... };
    check-names ( fail | warn | ignore );
    database <string>;
    delegation-only <boolean>; // deprecated
    dialup ( notify | notify-passive | passive | refresh | <boolean> ); //↳
↳deprecated
    file <quoted_string>;
    forward ( first | only );
    forwarders [ port <integer> ] { ( <ipv4_address> | <ipv6_address> ) [↳
↳port <integer> ]; ... };
```

(continues on next page)

(continued from previous page)

```

masterfile-format ( raw | text );
masterfile-style ( full | relative );
max-records <integer>;
max-records-per-type <integer>;
max-refresh-time <integer>;
max-retry-time <integer>;
max-transfer-idle-in <integer>;
max-transfer-time-in <integer>;
max-types-per-name <integer>;
min-refresh-time <integer>;
min-retry-time <integer>;
multi-master <boolean>;
primaries [ port <integer> ] { ( <remote-servers> | <ipv4_address> [ ↵
↵port <integer> ] | <ipv6_address> [ port <integer> ] ) [ key <string> ] [ tls
↵<string> ]; ... };
transfer-source ( <ipv4_address> | * );
transfer-source-v6 ( <ipv6_address> | * );
use-alt-transfer-source <boolean>; // deprecated
zone-statistics ( full | terse | none | <boolean> );
};

```

**Blocks:** zone, view.zone**Tags:** zone

Contains a duplicate of the NS records of a zone.

A stub zone specifies a set of name servers to use when contacting the zone for the first time. A stub zone overrides any NS records (delegations) that might exist in the parent zone. Once an authoritative server is reached, the NS records from that server are honored.

A stub zone can work around missing or broken delegations, but comes at expense of maintaining a set of name server addresses in *named.conf*.

**⚠ Warning**

Use of stub zones is not recommended. Proper delegation with NS records in the parent zone should be used.

*named* queries authoritative servers configured as *primaries* to obtain up-to-date NS records. These new NS records are then used to obtain answers from a given zone.

Stub zones can also be used as a way to force the resolution of a given domain to use a particular set of authoritative servers. For example, the caching name servers on a private network using **RFC 1918** addressing may be configured with stub zones for *10.in-addr.arpa* to use a set of internal name servers as the authoritative servers for that domain.

If a BIND 9 primary, serving a parent zone, has child stub zones configured, all the secondary servers for the parent zone also need to have the same child stub zones configured.

Stub zones are not a standard part of the DNS; they are a feature specific to the BIND implementation.

**type** static-stub**Grammar:**

```

zone <string> [ <class> ] {
    type static-stub;
    allow-query { <address_match_element>; ... };
    allow-query-on { <address_match_element>; ... };
    forward ( first | only );
    forwarders [ port <integer> ] { ( <ipv4_address> | <ipv6_address> ) [
↳port <integer> ]; ... };
    max-records <integer>;
    max-records-per-type <integer>;
    max-types-per-name <integer>;
    server-addresses { ( <ipv4_address> | <ipv6_address> ); ... };
    server-names { <string>; ... };
    zone-statistics ( full | terse | none | <boolean> );
};

```

**Blocks:** zone, view.zone

**Tags:** zone

Contains statically configured NS records for a zone.

A static-stub zone specifies a set of name servers to use to resolve *all* queries for the given zone. A stub zone overrides any NS records (delegations) that might exist in the parent zone, and also any records received from the otherwise-authoritative server.

Like a *stub* zone, this can work around missing or broken delegations at the parent. Unlike stub, static-stub also overrides any NS records offered by the specified servers.

When recursion is necessary for a query that matches a static-stub zone, the locally configured data (name server names and glue addresses) is always used, even if different authoritative information is cached.

The zone data is configured via the *server-addresses* and *server-names* zone statements. These must point to authoritative servers.

#### Warning

Use of static-stub zones is not recommended. Proper delegation with NS records in the parent zone should be used.

The zone data is maintained in the form of NS and (if necessary) glue A or AAAA RRs internally, which can be seen by dumping zone databases with *rndc dumpdb -all*. The configured RRs are considered local configuration parameters rather than public data. Non-recursive queries (i.e., those with the RD bit off) to a static-stub zone are therefore prohibited and are responded to with REFUSED.

Since the data is statically configured, no zone maintenance action takes place for a static-stub zone. For example, there is no periodic refresh attempt, and an incoming *NOTIFY* message is rejected with an rcode of NOTAUTH.

Each static-stub zone is configured with internally generated NS and (if necessary) glue A or AAAA RRs.

**type forward**

**Grammar:**

```

zone <string> [ <class> ] {
    type forward;
    delegation-only <boolean>; // deprecated

```

(continues on next page)

(continued from previous page)

```

forward ( first | only );
forwarders [ port <integer> ] { ( <ipv4_address> | <ipv6_address> ) [
↳port <integer> ]; ... };
};

```

**Blocks:** zone, view.zone**Tags:** zone

Contains forwarding statements that apply to queries within a given domain.

A forward zone is a way to configure forwarding on a per-domain basis. A *zone* statement of type *forward* can contain a *forward* and/or *forwarders* statement, which applies to queries within the domain given by the zone name. If no *forwarders* statement is present, or an empty list for *forwarders* is given, then no forwarding is done for the domain, canceling the effects of any forwarders in the *options* statement. Thus, to use this type of zone to change the behavior of the global *forward* option (that is, "forward first" to, then "forward only", or vice versa), but use the same servers as set globally, re-specify the global forwarders.

**type redirect****Grammar:**

```

zone <string> [ <class> ] {
  type redirect;
  allow-query { <address_match_element>; ... };
  allow-query-on { <address_match_element>; ... };
  dlz <string>;
  file <quoted_string>;
  masterfile-format ( raw | text );
  masterfile-style ( full | relative );
  max-records <integer>;
  max-records-per-type <integer>;
  max-types-per-name <integer>;
  max-zone-ttl ( unlimited | <duration> );
  primaries [ port <integer> ] { ( <remote-servers> | <ipv4_address> [
↳port <integer> ] | <ipv6_address> [ port <integer> ] ) [ key <string> ] [ tls
↳<string> ]; ... };
  zone-statistics ( full | terse | none | <boolean> );
};

```

**Blocks:** zone, view.zone**Tags:** zone

Contains information to answer queries when normal resolution would return NXDOMAIN.

Redirect zones are used to provide answers to queries when normal resolution would result in NXDOMAIN being returned. Only one redirect zone is supported per view. *allow-query* can be used to restrict which clients see these answers.

If the client has requested DNSSEC records (DO=1) and the NXDOMAIN response is signed, no substitution occurs.

To redirect all NXDOMAIN responses to 100.100.100.2 and 2001:fff:fff::100.100.100.2, configure a type *redirect* zone named ".", with the zone file containing wildcard records that point to the desired addresses: \*. IN A

100.100.100.2 and \*. IN AAAA 2001:ffff:ffff::100.100.100.2.

As another example, to redirect all Spanish names (under .ES), use similar entries but with the names \*.ES. instead of \*. To redirect all commercial Spanish names (under COM.ES), use wildcard entries called \*.COM.ES..

Note that the redirect zone supports all possible types; it is not limited to A and AAAA records.

If a redirect zone is configured with a *primaries* option, then it is transferred in as if it were a secondary zone. Otherwise, it is loaded from a file as if it were a primary zone.

Because redirect zones are not referenced directly by name, they are not kept in the zone lookup table with normal primary and secondary zones. To reload a redirect zone, use `rndc reload -redirect`; to retransfer a redirect zone configured as a secondary, use `rndc retransfer -redirect`. When using `rndc reload` without specifying a zone name, redirect zones are reloaded along with other zones.

### type delegation-only

#### Grammar:

```
zone <string> [ <class> ] {
    type delegation-only;
};
```

**Blocks:** zone, view.zone

**Tags:** deprecated

Enforces the delegation-only status of infrastructure zones (COM, NET, ORG, etc.).

This zone type is used to enforce the delegation-only status of infrastructure zones (e.g., COM, NET, ORG). Any answer that is received without an explicit or implicit delegation in the authority section is treated as NXDOMAIN. This does not apply to the zone apex, and should not be applied to leaf zones.

*delegation-only* has no effect on answers received from forwarders.

See caveats in *root-delegation-only*.

This zone type is deprecated, and will be rendered non-operational in a future release.

### in-view

#### Grammar zone, view.zone:

```
zone <string> [ <class> ] {
    in-view <string>;
};
```

**Grammar zone (in-view):** in-view <string>;

**Blocks:** zone, zone (in-view), view.zone

**Tags:** view, zone

Specifies the view in which a given zone is defined.

When using multiple views, a *type primary* or *type secondary* zone configured in one view can be referenced in a subsequent view. This allows both views to use the same zone without the overhead of loading it more than once. This is configured using a *zone* statement, with an *in-view* option specifying the view in which the zone is defined. A *zone* statement containing *in-view* does not need to specify a type, since that is part of the zone definition in the other view.

See *Multiple Views* for more information.

## Class

The zone's name may optionally be followed by a class. If a class is not specified, class `IN` (for `Internet`) is assumed. This is correct for the vast majority of cases.

The `hesiod` class is named for an information service from MIT's Project Athena. It was used to share information about various systems databases, such as users, groups, printers, and so on. The keyword `HS` is a synonym for `hesiod`.

Another MIT development is Chaosnet, a LAN protocol created in the mid-1970s. Zone data for it can be specified with the `CHAOS` class.

## Zone Options

### *allow-notify*

See the description of *allow-notify* in *Access Control*.

### *allow-query*

See the description of *allow-query* in *Access Control*.

### *allow-query-on*

See the description of *allow-query-on* in *Access Control*.

### *allow-transfer*

See the description of *allow-transfer* in *Access Control*.

### *allow-update*

See the description of *allow-update* in *Access Control*.

### *update-policy*

This specifies a "Simple Secure Update" policy. See *Dynamic Update Policies*.

### *allow-update-forwarding*

See the description of *allow-update-forwarding* in *Access Control*.

### *also-notify*

This option is only meaningful if *notify* is active for this zone. The set of machines that receive a `DNS NOTIFY` message for this zone is made up of all the listed name servers (other than the primary) for the zone, plus any IP addresses specified with *also-notify*. A port may be specified with each *also-notify* address to send the notify messages to a port other than the default of 53. A TSIG key may also be specified to cause the `NOTIFY` to be signed by the given key. *also-notify* is not meaningful for stub zones. The default is the empty list.

### *check-names*

This option is used to restrict the character set and syntax of certain domain names in primary files and/or DNS responses received from the network. The default varies according to zone type. For *primary* zones the default is `fail`; for *secondary* zones the default is `warn`. It is not implemented for *hint* zones.

### *check-mx*

See the description of *check-mx* in *Boolean Options*.

### *check-spf*

See the description of *check-spf* in *Boolean Options*.

### *check-wildcard*

See the description of *check-wildcard* in *Boolean Options*.

### *check-integrity*

See the description of *check-integrity* in *Boolean Options*.

### *check-sibling*

See the description of *check-sibling* in *Boolean Options*.

### *zero-no-soa-ttl*

See the description of *zero-no-soa-ttl* in *Boolean Options*.

*update-check-ksk*

See the description of *update-check-ksk* in *Boolean Options*.

*dnssec-loadkeys-interval*

See the description of *dnssec-loadkeys-interval* in *options*.

*dnssec-update-mode*

See the description of *dnssec-update-mode* in *options*.

*dnssec-dnskey-kskonly*

See the description of *dnssec-dnskey-kskonly* in *Boolean Options*.

*try-tcp-refresh*

See the description of *try-tcp-refresh* in *Boolean Options*.

**database**

**Grammar:** `database <string>;`

**Blocks:** `dlz, zone (mirror, primary, secondary, stub), view.dlz`

**Tags:** `zone`

Specifies the type of database to be used to store zone data.

This specifies the type of database to be used to store the zone data. The string following the *database* keyword is interpreted as a list of whitespace-delimited words. The first word identifies the database type, and any subsequent words are passed as arguments to the database to be interpreted in a way specific to the database type.

The default is `rbt`, BIND 9's native in-memory red-black tree database. This database does not take arguments.

Other values are possible if additional database drivers have been linked into the server. Some sample drivers are included with the distribution but none are linked in by default.

*dialup*

See the description of *dialup* in *Boolean Options*.

**delegation-only**

 **Warning**

This option is deprecated and will be removed in a future version of BIND.

**Grammar:** `delegation-only <boolean>; // deprecated`

**Blocks:** `zone (forward, hint, stub)`

**Tags:** `deprecated`

Indicates that a forward, hint, or stub zone is to be treated as a delegation-only type zone.

This flag only applies to forward, hint, and stub zones. If set to *yes*, then the zone is treated as if it is also a delegation-only type zone.

See caveats in *root-delegation-only*.

This option is deprecated, and will be rendered non-operational in a future release.

**file**

**Grammar** `logging.channel: file <quoted_string> [ versions ( unlimited | <integer> ) ] [ size <size> ] [ suffix ( increment | timestamp ) ];`

**Grammar zone (hint, mirror, primary, redirect, secondary, stub):** `file <quoted_string>;`

**Blocks:** zone (hint, mirror, primary, redirect, secondary, stub), logging.channel

**Tags:** zone

Specifies the zone's filename.

This sets the zone's filename. In *primary*, *hint*, and *redirect* zones which do not have *primaries* defined, zone data is loaded from this file. In *secondary*, *mirror*, *stub*, and *redirect* zones which do have *primaries* defined, zone data is retrieved from another server and saved in this file. This option is not applicable to other zone types.

*forward*

This option is only meaningful if the zone has a forwarders list. The `only` value causes the lookup to fail after trying the forwarders and getting no answer, while `first` allows a normal lookup to be tried.

*forwarders*

This is used to override the list of global forwarders. If it is not specified in a zone of type *forward*, no forwarding is done for the zone and the global options are not used.

**journal**

**Grammar:** `journal <quoted_string>;`

**Blocks:** zone (mirror, primary, secondary)

**Tags:** zone

Allows the default journal's filename to be overridden.

This allows the default journal's filename to be overridden. The default is the zone's filename with ".jnl" appended. This is applicable to *primary* and *secondary* zones.

*max-ixfr-ratio*

See the description of *max-ixfr-ratio* in *options*.

*max-journal-size*

See the description of *max-journal-size* in *Server Resource Limits*.

*max-records*

See the description of *max-records* in *Server Resource Limits*.

*max-transfer-time-in*

See the description of *max-transfer-time-in* in *Zone Transfers*.

*max-transfer-idle-in*

See the description of *max-transfer-idle-in* in *Zone Transfers*.

*max-transfer-time-out*

See the description of *max-transfer-time-out* in *Zone Transfers*.

*max-transfer-idle-out*

See the description of *max-transfer-idle-out* in *Zone Transfers*.

*notify*

See the description of *notify* in *Boolean Options*.

**notify-delay**

See the description of *notify-delay* in *Tuning*.

**notify-to-soa**

See the description of *notify-to-soa* in *Boolean Options*.

**zone-statistics**

See the description of *zone-statistics* in *options*.

**server-addresses**

**Grammar:** `server-addresses { ( <ipv4_address> | <ipv6_address> ); ... };`

**Blocks:** zone (static-stub)

**Tags:** query, zone

Specifies a list of IP addresses to which queries should be sent in recursive resolution for a static-stub zone.

This option is only meaningful for *static-stub* zones. This is a list of IP addresses to which queries should be sent in recursive resolution for the zone. A non-empty list for this option internally configures the apex NS RR with associated glue A or AAAA RRs.

For example, if "example.com" is configured as a static-stub zone with 192.0.2.1 and 2001:db8::1234 in a *server-addresses* option, the following RRs are internally configured:

```
example.com. NS example.com.
example.com. A 192.0.2.1
example.com. AAAA 2001:db8::1234
```

These records are used internally to resolve names under the static-stub zone. For instance, if the server receives a query for "www.example.com" with the RD bit on, the server initiates recursive resolution and sends queries to 192.0.2.1 and/or 2001:db8::1234.

**server-names**

**Grammar:** `server-names { <string>; ... };`

**Blocks:** zone (static-stub)

**Tags:** zone

Specifies a list of domain names of name servers that act as authoritative servers of a static-stub zone.

This option is only meaningful for *static-stub* zones. This is a list of domain names of name servers that act as authoritative servers of the static-stub zone. These names are resolved to IP addresses when *named* needs to send queries to these servers. For this supplemental resolution to be successful, these names must not be a subdomain of the origin name of the static-stub zone. That is, when "example.net" is the origin of a static-stub zone, "ns.example" and "master.example.com" can be specified in the *server-names* option, but "ns.example.net" cannot; it is rejected by the configuration parser.

A non-empty list for this option internally configures the apex NS RR with the specified names. For example, if "example.com" is configured as a static-stub zone with "ns1.example.net" and "ns2.example.net" in a *server-names* option, the following RRs are internally configured:

```
example.com. NS ns1.example.net.
example.com. NS ns2.example.net.
```

These records are used internally to resolve names under the static-stub zone. For instance, if the server receives a query for "www.example.com" with the RD bit on, the server initiates recursive resolution, resolves

"ns1.example.net" and/or "ns2.example.net" to IP addresses, and then sends queries to one or more of these addresses.

***sig-validity-interval***

See the description of *sig-validity-interval* in *Tuning*.

***sig-signing-nodes***

See the description of *sig-signing-nodes* in *Tuning*.

***sig-signing-signatures***

See the description of *sig-signing-signatures* in *Tuning*.

***sig-signing-type***

See the description of *sig-signing-type* in *Tuning*.

***transfer-source***

See the description of *transfer-source* in *Zone Transfers*.

***transfer-source-v6***

See the description of *transfer-source-v6* in *Zone Transfers*.

***alt-transfer-source***

See the description of *alt-transfer-source* in *Zone Transfers*.

***alt-transfer-source-v6***

See the description of *alt-transfer-source-v6* in *Zone Transfers*.

***use-alt-transfer-source***

See the description of *use-alt-transfer-source* in *Zone Transfers*.

***notify-source***

See the description of *notify-source* in *Zone Transfers*.

***notify-source-v6***

See the description of *notify-source-v6* in *Zone Transfers*.

***min-refresh-time; max-refresh-time; min-retry-time; max-retry-time***

See the descriptions in *Tuning*.

***ixfr-from-differences***

See the description of *ixfr-from-differences* in *Boolean Options*. (Note that the *ixfr-from-differences* choices of *primary* and *secondary* are not available at the zone level.)

***key-directory***

See the description of *key-directory* in *options*.

***auto-dnssec***

See the description of *auto-dnssec* in *options*.

***serial-update-method***

See the description of *serial-update-method* in *options*.

***inline-signing***

**Grammar:** *inline-signing* <boolean>;

**Blocks:** zone (primary, secondary)

**Tags:** dnssec, zone

Specifies whether BIND 9 maintains a separate signed version of a zone.

If *yes*, BIND 9 maintains a separate signed version of the zone. An unsigned zone is transferred in or loaded from disk and the signed version of the zone is served with, possibly, a different serial number. The signed version of

the zone is stored in a file that is the zone's filename (set in *file*) with a *.signed* extension. This behavior is disabled by default.

***multi-master***

See the description of *multi-master* in *Boolean Options*.

***masterfile-format***

See the description of *masterfile-format* in *Tuning*.

***max-zone-ttl***

See the description of *max-zone-ttl* in *options*. The use of this option in *zone* blocks is deprecated and will be rendered nonoperational in a future release.

***dnssec-secure-to-insecure***

See the description of *dnssec-secure-to-insecure* in *Boolean Options*.

### Dynamic Update Policies

BIND 9 supports two methods of granting clients the right to perform dynamic updates to a zone:

- *allow-update* - a simple access control list
- *update-policy* - fine-grained access control

In both cases, BIND 9 writes the updates to the zone's filename set in *file*.

In the case of a DNSSEC zone, DNSSEC records are also written to the zone's filename, unless *inline-signing* is enabled.

**Note**

The zone file can no longer be manually updated while *named* is running; it is now necessary to perform *rndc freeze*, edit, and then perform *rndc thaw*. Comments and formatting in the zone file are lost when dynamic updates occur.

**update-policy**

**Grammar:** `update-policy ( local | { ( deny | grant ) <string> ( 6to4-self | external | krb5-self | krb5-selfsub | krb5-subdomain | krb5-subdomain-self-rhs | ms-self | ms-selfsub | ms-subdomain | ms-subdomain-self-rhs | name | self | selfsub | selfwild | subdomain | tcp-self | wildcard | zonesub ) [ <string> ] <rdatatype>; ... } );`

**Blocks:** zone (primary)

**Tags:** transfer

Sets fine-grained rules to allow or deny dynamic updates (DDNS), based on requester identity, updated content, etc.

The *update-policy* clause allows more fine-grained control over which updates are allowed. It specifies a set of rules, in which each rule either grants or denies permission for one or more names in the zone to be updated by one or more identities. Identity is determined by the key that signed the update request, using TSIG. In most cases, *update-policy* rules only apply to key-based identities. There is no way to specify update permissions based on the client source address.

*update-policy* rules are only meaningful for zones of *type primary*, and are not allowed in any other zone type. It is a configuration error to specify both *allow-update* and *update-policy* at the same time.

A pre-defined *update-policy* rule can be switched on with the command `update-policy local;`. *named* automatically generates a TSIG session key when starting and stores it in a file; this key can then be used by local clients to update the zone while *named* is running. By default, the session key is stored in the file `/usr/local/var/run/session.key`, the key name is "local-ddns", and the key algorithm is HMAC-SHA256. These values are configurable with the *session-keyfile*, *session-keyname*, and *session-keyalg* options, respectively. A client running on the local system, if run with appropriate permissions, may read the session key from the key file and use it to sign update requests. The zone's update policy is set to allow that key to change any record within the zone. Assuming the key name is "local-ddns", this policy is equivalent to:

```
update-policy { grant local-ddns zonesub any; };
```

with the additional restriction that only clients connecting from the local system are permitted to send updates.

Note that only one session key is generated by *named*; all zones configured to use `update-policy local` accept the same key.

The command `nsupdate -l` implements this feature, sending requests to localhost and signing them using the key retrieved from the session key file.

Other rule definitions look like this:

```
( grant | deny ) identity ruletype name types
```

Each rule grants or denies privileges. Rules are checked in the order in which they are specified in the *update-policy* statement. Once a message has successfully matched a rule, the operation is immediately granted or denied, and no further rules are examined. There are 16 types of rules; the rule type is specified by the *ruletype* field, and the interpretation of other fields varies depending on the rule type.

In general, a rule is matched when the key that signed an update request matches the *identity* field, the name of the record to be updated matches the *name* field (in the manner specified by the *ruletype* field), and the type of the record to be updated matches the *types* field. Details for each rule type are described below.

The *identity* field must be set to a fully qualified domain name. In most cases, this represents the name of the TSIG key that must be used to sign the update request. If the specified name is a wildcard, it is subject to DNS wildcard expansion, and the rule may apply to multiple identities. When a TKEY exchange has been used to create a shared secret, the identity of the key used to authenticate the TKEY exchange is used as the identity of the shared secret. Some rule types use identities matching the client's Kerberos principal (e.g. "host/machine@REALM") or Windows realm (machine\$@REALM).

The *name* field also specifies a fully qualified domain name. This often represents the name of the record to be updated. Interpretation of this field is dependent on rule type.

If no *types* are explicitly specified, then a rule matches all types except RRSIG, NS, SOA, NSEC, and NSEC3. Types may be specified by name, including ANY; ANY matches all types except NSEC and NSEC3, which can never be updated. Note that when an attempt is made to delete all records associated with a name, the rules are checked for each existing record type.

If the type is immediately followed by a number in parentheses, that number is the maximum number of records of that type permitted to exist in the RRset after an update has been applied. For example, `PTR(1)` indicates that only one PTR record is allowed. If an attempt is made to add two PTR records in an update, the second one is silently discarded. If a PTR record already exists, both new records are silently discarded.

If type ANY is specified with a limit, then that limit applies to all types that are not otherwise specified. For example, `A PTR(1) ANY(2)` indicates that an unlimited number of A records can exist, but only one PTR record, and no more than two of any other type.

Typical use with a rule `grant * tcp-self . PTR(1);` in the zone `2.0.192.IN-ADDR.ARPA` looks like this:

```

nsupdate -v <<EOF
local 192.0.2.1
del 1.2.0.192.IN-ADDR.ARPA PTR
add 1.2.0.192.IN-ADDR.ARPA 0 PTR EXAMPLE.COM
send
EOF

```

The `ruletype` field has 18 values: `name`, `subdomain`, `zonesub`, `wildcard`, `self`, `selfsub`, `self-wild`, `ms-self`, `ms-selfsub`, `ms-subdomain`, `ms-subdomain-self-rhs`, `krb5-self`, `krb5-selfsub`, `krb5-subdomain`, `krb5-subdomain-self-rhs`, `tcp-self`, `6to4-self`, and `external`.

#### **name**

With exact-match semantics, this rule matches when the name being updated is identical to the contents of the `name` field.

#### **subdomain**

This rule matches when the name being updated is a subdomain of, or identical to, the contents of the `name` field.

#### **zonesub**

This rule is similar to `subdomain`, except that it matches when the name being updated is a subdomain of the zone in which the `update-policy` statement appears. This obviates the need to type the zone name twice, and enables the use of a standard `update-policy` statement in multiple zones without modification. When this rule is used, the `name` field is omitted.

#### **wildcard**

The `name` field is subject to DNS wildcard expansion, and this rule matches when the name being updated is a valid expansion of the wildcard.

#### **self**

This rule matches when the name of the record being updated matches the contents of the `identity` field. The `name` field is ignored. To avoid confusion, it is recommended that this field be set to the same value as the `identity` field or to "." The `self` rule type is most useful when allowing one key per name to update, where the key has the same name as the record to be updated. In this case, the `identity` field can be specified as \* (asterisk).

#### **selfsub**

This rule is similar to `self`, except that subdomains of `self` can also be updated.

#### **selfwild**

This rule is similar to `self`, except that only subdomains of `self` can be updated.

#### **ms-self**

When a client sends an UPDATE using a Windows machine principal (for example, `machine$@REALM`), this rule allows records with the absolute name of `machine.REALM` to be updated.

The realm to be matched is specified in the `identity` field.

The `name` field has no effect on this rule; it should be set to "." as a placeholder.

For example, `grant EXAMPLE.COM ms-self . AAAA` allows any machine with a valid principal in the realm `EXAMPLE.COM` to update its own address records.

#### **ms-selfsub**

This is similar to `ms-self`, except it also allows updates to any subdomain of the name specified in the Windows machine principal, not just to the name itself.

#### **ms-subdomain**

When a client sends an UPDATE using a Windows machine principal (for example, `machine$@REALM`), this

rule allows any machine in the specified realm to update any record in the zone or in a specified subdomain of the zone.

The realm to be matched is specified in the `identity` field.

The `name` field specifies the subdomain that may be updated. If set to "." or any other name at or above the zone apex, any name in the zone can be updated.

For example, if `update-policy` for the zone "example.com" includes `grant EXAMPLE.COM ms-subdomain hosts.example.com. AA AAAA`, any machine with a valid principal in the realm `EXAMPLE.COM` is able to update address records at or below `hosts.example.com`.

**ms-subdomain-self-rhs**

This rule is similar to `ms-subdomain`, with an additional restriction that PTR and SRV target names must match the name of the machine identified in the principal.

**krb5-self**

When a client sends an UPDATE using a Kerberos machine principal (for example, `host/machine@REALM`), this rule allows records with the absolute name of `machine` to be updated, provided it has been authenticated by `REALM`. This is similar but not identical to `ms-self`, due to the `machine` part of the Kerberos principal being an absolute name instead of an unqualified name.

The realm to be matched is specified in the `identity` field.

The `name` field has no effect on this rule; it should be set to "." as a placeholder.

For example, `grant EXAMPLE.COM krb5-self . A AAAA` allows any machine with a valid principal in the realm `EXAMPLE.COM` to update its own address records.

**krb5-selfsub**

This is similar to `krb5-self`, except it also allows updates to any subdomain of the name specified in the `machine` part of the Kerberos principal, not just to the name itself.

**krb5-subdomain**

This rule is identical to `ms-subdomain`, except that it works with Kerberos machine principals (i.e., `host/machine@REALM`) rather than Windows machine principals.

**krb5-subdomain-self-rhs**

This rule is similar to `krb5-subdomain`, with an additional restriction that PTR and SRV target names must match the name of the machine identified in the principal.

**tcp-self**

This rule allows updates that have been sent via TCP and for which the standard mapping from the client's IP address into the `in-addr.arpa` and `ip6.arpa` namespaces matches the name to be updated. The `identity` field must match that name. The `name` field should be set to ".". Note that, since `identity` is based on the client's IP address, it is not necessary for update request messages to be signed.

 **Note**

It is theoretically possible to spoof these TCP sessions.

**6to4-self**

This allows the name matching a 6to4 IPv6 prefix, as specified in [RFC 3056](#), to be updated by any TCP connection from either the 6to4 network or from the corresponding IPv4 address. This is intended to allow NS or DNAME RRsets to be added to the `ip6.arpa` reverse tree.

The `identity` field must match the 6to4 prefix in `ip6.arpa`. The `name` field should be set to ".". Note that, since `identity` is based on the client's IP address, it is not necessary for update request messages to be signed.

In addition, if specified for an `ip6.arpa` name outside of the `2.0.0.2.ip6.arpa` namespace, the corresponding /48 reverse name can be updated. For example, TCP/IPv6 connections from `2001:DB8:ED0C::/48` can update records at `C.0.D.E.8.B.D.0.1.0.0.2.ip6.arpa`.

#### Note

It is theoretically possible to spoof these TCP sessions.

#### external

This rule allows *named* to defer the decision of whether to allow a given update to an external daemon.

The method of communicating with the daemon is specified in the `identity` field, the format of which is `"local:path"`, where "path" is the location of a Unix-domain socket. (Currently, "local" is the only supported mechanism.)

Requests to the external daemon are sent over the Unix-domain socket as datagrams with the following format:

```
Protocol version number (4 bytes, network byte order, currently 1)
Request length (4 bytes, network byte order)
Signer (null-terminated string)
Name (null-terminated string)
TCP source address (null-terminated string)
Rdata type (null-terminated string)
Key (null-terminated string)
TKEY token length (4 bytes, network byte order)
TKEY token (remainder of packet)
```

The daemon replies with a four-byte value in network byte order, containing either 0 or 1; 0 indicates that the specified update is not permitted, and 1 indicates that it is.

#### Warning

The external daemon must not delay communication. This policy is evaluated synchronously; any wait period negatively affects *named* performance.

## Multiple Views

When multiple views are in use, a zone may be referenced by more than one of them. Often, the views contain different zones with the same name, allowing different clients to receive different answers for the same queries. At times, however, it is desirable for multiple views to contain identical zones. The `in-view` zone option provides an efficient way to do this; it allows a view to reference a zone that was defined in a previously configured view. For example:

```
view internal {
    match-clients { 10/8; };

    zone example.com {
        type primary;
        file "example-external.db";
    };
};

view external {
    match-clients { any; };
```

(continues on next page)

(continued from previous page)

```
zone example.com {
  in-view internal;
};
};
```

An *in-view* option cannot refer to a view that is configured later in the configuration file.

A *zone* statement which uses the *in-view* option may not use any other options, with the exception of *forward* and *forwarders*. (These options control the behavior of the containing view, rather than change the zone object itself.)

Zone-level ACLs (e.g., *allow-query*, *allow-transfer*), and other configuration details of the zone, are all set in the view the referenced zone is defined in. Be careful to ensure that ACLs are wide enough for all views referencing the zone.

An *in-view* zone cannot be used as a response policy zone.

An *in-view* zone is not intended to reference a *forward* zone.

### 8.3 Statements

BIND 9 supports many hundreds of statements; finding the right statement to control a specific behavior or solve a particular problem can be a daunting task. To simplify the task for users, all statements have been assigned one or more tags. Tags are designed to group together statements that have broadly similar functionality; thus, for example, all statements that control the handling of queries or of zone transfers are respectively tagged under **query** and **transfer**.

*DNSSEC Tag Statements* are those that relate to or control DNSSEC.

*Logging Tag Statements* relate to or control logging, and typically only appear in a logging block.

*Query Tag Statements* relate to or control queries.

*Security Tag Statements* relate to or control security features.

*Server Tag Statements* relate to or control server behavior, and typically only appear in a server block.

*Transfer Tag Statements* relate to or control zone transfers.

*View Tag Statements* relate to or control view selection criteria, and typically only appear in a view block.

*Zone Tag Statements* relate to or control zone behavior, and typically only appear in a zone block.

*Deprecated Tag Statements* are those that are now deprecated, but are included here for historical reference.

The following table lists all statements permissible in `named.conf`, with their associated tags; the next section groups the statements by tag. Please note that these sections are a work in progress.

Statement	Description	Tags
<i>acl</i>	Assigns a symbolic name to an address match list.	server
<i>algorithm</i>	Defines the algorithm to be used in a key clause.	security
<i>all-per-second</i>	Limits UDP responses of all kinds.	query

continues on next page

Table 1 – continued from previous page

Statement	Description	Tags
<i>allow-new-zones</i>	Controls the ability to add zones at runtime via <i>rndc addzone</i> .	server, zone
<i>allow-notify</i>	Defines an <i>address_match_list</i> that is allowed to send NOTIFY messages for the zone, in addition to addresses defined in the <i>primaries</i> option for the zone.	transfer
<i>allow-query</i>	Specifies which hosts (an IP address list) are allowed to send queries to this resolver.	query
<i>allow-query-cache</i>	Specifies which hosts (an IP address list) can access this server's cache and thus effectively controls recursion.	query
<i>allow-query-cache-on</i>	Specifies which hosts (an IP address list) can access this server's cache. Used on servers with multiple interfaces.	query
<i>allow-query-on</i>	Specifies which local addresses (an IP address list) are allowed to send queries to this resolver. Used in multi-homed configurations.	query
<i>allow-recursion</i>	Defines an <i>address_match_list</i> of clients that are allowed to perform recursive queries.	query
<i>allow-recursion-on</i>	Specifies which local addresses can accept recursive queries.	query, server
<i>allow-transfer</i>	Defines an <i>address_match_list</i> of hosts that are allowed to transfer the zone information from this server.	transfer
<i>allow-update</i>	Defines an <i>address_match_list</i> of hosts that are allowed to submit dynamic updates for primary zones.	transfer
<i>allow-update-forwarding</i>	Defines an <i>address_match_list</i> of hosts that are allowed to submit dynamic updates to a secondary server for transmission to a primary.	transfer

continues on next page

Table 1 – continued from previous page

Statement	Description	Tags
<i>also-notify</i>	Defines one or more hosts that are sent NOTIFY messages when zone changes occur.	transfer
<i>alt-transfer-source</i>	Defines alternate local IPv4 address(es) to be used by the server for inbound zone transfers, if the address(es) defined by <i>transfer-source</i> fail and <i>use-alt-transfer-source</i> is enabled.	deprecated
<i>alt-transfer-source-v6</i>	Defines alternate local IPv6 address(es) to be used by the server for inbound zone transfers.	deprecated
<i>answer-cookie</i>	Controls whether COOKIE EDNS replies are sent in response to client queries.	query
<i>attach-cache</i>	Allows multiple views to share a single cache database.	view
<i>auth-nxdomain</i>	Controls whether BIND, acting as a resolver, provides authoritative NXDOMAIN (domain does not exist) answers.	query
<i>auto-dnssec</i>	Permits varying levels of automatic DNSSEC key management.	dnssec
<i>automatic-interface-scan</i>	Controls the automatic rescanning of network interfaces when addresses are added or removed.	server
<i>avoid-v4-udp-ports</i>	Specifies the range(s) of ports to be excluded from use as sources for UDP/IPv4 messages.	deprecated
<i>avoid-v6-udp-ports</i>	Specifies the range(s) of ports to be excluded from use as sources for UDP/IPv6 messages.	deprecated
<i>bindkeys-file</i>	Specifies the pathname of a file to override the built-in trusted keys provided by <i>named</i> .	dnssec

continues on next page

Table 1 – continued from previous page

Statement	Description	Tags
<i>blackhole</i>	Defines an <i>address_match_list</i> of hosts to ignore. The server will neither respond to queries from nor send queries to these addresses.	query
<i>bogus</i>	Allows a remote server to be ignored.	server
<i>break-dnssec</i>	Enables <i>dns64</i> synthesis even if the validated result would cause a DNSSEC validation failure.	query
<i>buffered</i>	Controls flushing of log messages.	logging
<i>ca-file</i>	Specifies the path to a file containing TLS certificates for trusted CA authorities, used to verify remote peer certificates.	server, security
<i>catalog-zones</i>	Configures catalog zones in <i>named.conf</i> .	zone
<i>category</i>	Specifies the type of data logged to a particular channel.	logging
<i>cert-file</i>	Specifies the path to a file containing the TLS certificate for a connection.	server, security
<i>channel</i>	Defines a stream of data that can be independently logged.	logging
<i>check-dup-records</i>	Checks primary zones for records that are treated as different by DNSSEC but are semantically equal in plain DNS.	dnssec, query
<i>check-integrity</i>	Performs post-load zone integrity checks on primary zones.	zone
<i>check-mx</i>	Checks whether an MX record appears to refer to an IP address.	zone
<i>check-mx-cname</i>	Sets the response to MX records that refer to CNAMEs.	zone
<i>check-names</i>	Restricts the character set and syntax of certain domain names in primary files and/or DNS responses received from the network.	query, server

continues on next page

Table 1 – continued from previous page

Statement	Description	Tags
<i>check-sibling</i>	Specifies whether to check for sibling glue when performing integrity checks.	zone
<i>check-spf</i>	Specifies whether to check for a TXT Sender Policy Framework record, if an SPF record is present.	zone
<i>check-srv-cname</i>	Sets the response to SRV records that refer to CNAMEs.	zone
<i>check-wildcard</i>	Checks for non-terminal wildcards.	zone
<i>ciphers</i>	Specifies a list of allowed ciphers.	security
<i>clients</i>	Specifies an access control list (ACL) of clients that are affected by a given <i>dns64</i> directive.	query
<i>clients-per-query</i>	Sets the initial minimum number of simultaneous recursive clients accepted by the server for any given query before the server drops additional clients.	server
<i>controls</i>	Specifies control channels to be used to manage the name server.	server
<i>cookie-algorithm</i>	Sets the algorithm to be used when generating a server cookie.	server
<i>cookie-secret</i>	Specifies a shared secret used for generating and verifying EDNS COOKIE options within an anycast cluster.	server
<i>coresize</i>	Sets the maximum size of a core dump.	deprecated
<i>database</i>	Specifies the type of database to be used to store zone data.	zone
<i>datasize</i>	Sets the maximum amount of data memory that can be used by the server.	deprecated
<i>delegation-only</i>	Indicates that a forward, hint, or stub zone is to be treated as a delegation-only type zone.	deprecated

continues on next page

Table 1 – continued from previous page

Statement	Description	Tags
<i>deny-answer-addresses</i>	Rejects A or AAAA records if the corresponding IPv4 or IPv6 addresses match a given <i>address_match_list</i> .	query
<i>deny-answer-aliases</i>	Rejects CNAME or DNAME records if the "alias" name matches a given list of <i>domain_name</i> elements.	query
<i>dhparam-file</i>	Specifies the path to a file containing Diffie-Hellman parameters, for enabling cipher suites.	server, security
<i>dialup</i>	Concentrates zone maintenance so that all transfers take place once every <i>heartbeat-interval</i> , ideally during a single call.	deprecated
<i>directory</i>	Sets the server's working directory.	server
<i>disable-algorithms</i>	Disables DNSSEC algorithms from a specified zone.	dnssec
<i>disable-ds-digests</i>	Disables DS digest types from a specified zone.	dnssec, zone
<i>disable-empty-zone</i>	Disables individual empty zones.	server, zone
<i>dlz</i>	Configures a Dynamically Loadable Zone (DLZ) database in <i>named.conf</i> .	zone
<i>dns64</i>	Instructs <i>named</i> to return mapped IPv4 addresses to AAAA queries when there are no AAAA records.	query
<i>dns64-contact</i>	Specifies the name of the contact for <i>dns64</i> zones.	server
<i>dns64-server</i>	Specifies the name of the server for <i>dns64</i> zones.	server
<i>dnskey-sig-validity</i>	Specifies the number of days in the future when automatically generated DNSSEC signatures expire.	dnssec
<i>dnskey-ttl</i>	Specifies the time to live (TTL) for DNSKEY resource records.	dnssec

continues on next page

Table 1 – continued from previous page

Statement	Description	Tags
<i>dnssrps-enable</i>	Turns on the DNS Response Policy Service (DNSRPS) interface.	server, security
<i>dnssrps-options</i>	Provides additional RPZ configuration settings, which are passed to the DNS Response Policy Service (DNSRPS) provider library.	server, security
<i>dnsssec-accept-expired</i>	Instructs BIND 9 to accept expired DNSSEC signatures when validating.	dnsssec
<i>dnsssec-dnskey-kskonly</i>	Specifies that only key-signing keys are used to sign the DNSKEY, CDNSKEY, and CDS RRsets at a zone's apex.	dnsssec
<i>dnsssec-loadkeys-interval</i>	Sets the frequency of automatic checks of the DNSSEC key repository.	dnsssec
<i>dnsssec-must-be-secure</i>	Defines hierarchies that must or may not be secure (signed and validated).	deprecated
<i>dnsssec-policy</i>	Defines a key and signing policy (KASP) for zones.	dnsssec
<i>dnsssec-secure-to-insecure</i>	Allows a dynamic zone to transition from secure to insecure by deleting all DNSKEY records.	dnsssec
<i>dnsssec-update-mode</i>	Controls the scheduled maintenance of DNSSEC signatures.	dnsssec
<i>dnsssec-validation</i>	Enables DNSSEC validation in <i>named</i> .	dnsssec
<i>dnstap</i>	Enables logging of <i>dnstap</i> messages.	logging
<i>dnstap-identity</i>	Specifies an <i>identity</i> string to send in <i>dnstap</i> messages.	logging
<i>dnstap-output</i>	Configures the path to which the <i>dnstap</i> frame stream is sent.	logging
<i>dnstap-version</i>	Specifies a <i>version</i> string to send in <i>dnstap</i> messages.	logging

continues on next page

Table 1 – continued from previous page

Statement	Description	Tags
<i>dscp</i>	Sets the Differentiated Services Code Point (DSCP) value (obsolete).	server, query
<i>dual-stack-servers</i>	Specifies host names or addresses of machines with access to both IPv4 and IPv6 transports.	server
<i>dump-file</i>	Indicates the pathname of the file where the server dumps the database after <i>rndc dumpdb</i> .	logging
<i>dyndb</i>	Configures a DynDB database in <i>named.conf</i> .	zone
<i>edns</i>	Controls the use of the EDNS0 (RFC 2671) feature.	server
<i>edns-udp-size</i>	Sets the maximum advertised EDNS UDP buffer size to control the size of packets received from authoritative servers in response to recursive queries.	query
<i>edns-version</i>	Sets the maximum EDNS VERSION that is sent to the server(s) by the resolver.	server
<i>empty-contact</i>	Specifies the contact name in the returned SOA record for empty zones.	server, zone
<i>empty-server</i>	Specifies the server name in the returned SOA record for empty zones.	server, zone
<i>empty-zones-enable</i>	Enables or disables all empty zones.	server, zone
<i>endpoints</i>	Specifies a list of HTTP query paths on which to listen.	server, query
<i>errors-per-second</i>	Limits the number of errors for a valid domain name and record type.	server
<i>exclude</i>	Allows a list of IPv6 addresses to be ignored if they appear in a domain name's AAAA records in <i>dns64</i> .	query
<i>exempt-clients</i>	Exempts specific clients or client groups from rate limiting.	query

continues on next page

Table 1 – continued from previous page

Statement	Description	Tags
<i>fetch-quota-params</i>	Sets the parameters for dynamic resizing of the <i>fetches-per-server</i> quota in response to detected congestion.	server, query
<i>fetches-per-server</i>	Sets the maximum number of simultaneous iterative queries allowed to be sent by a server to an upstream name server before the server blocks additional queries.	server, query
<i>fetches-per-zone</i>	Sets the maximum number of simultaneous iterative queries allowed to any one domain before the server blocks new queries for data in or beneath that zone.	server, query
<i>file</i>	Specifies the zone's filename.	zone
<i>files</i>	Sets the maximum number of files the server may have open concurrently.	deprecated
<i>flush-zones-on-shutdown</i>	Controls whether pending zone writes are flushed when the name server exits.	zone
<i>forward</i>	Allows or disallows fallback to recursion if forwarding has failed; it is always used in conjunction with the <i>forwarders</i> statement.	query
<i>forwarders</i>	Defines one or more resolvers to which queries are forwarded.	query
<i>fstrm-set-buffer-hint</i>	Sets the number of accumulated bytes in the output buffer before forcing a buffer flush.	logging
<i>fstrm-set-flush-timeout</i>	Sets the number of seconds that unflushed data remains in the output buffer.	logging
<i>fstrm-set-input-queue-size</i>	Sets the number of queue entries to allocate for each input queue.	logging
<i>fstrm-set-output-notify-threshold</i>	Sets the number of outstanding queue entries allowed on an input queue before waking the I/O thread.	logging

continues on next page

Table 1 – continued from previous page

Statement	Description	Tags
<i>fstrm-set-output-queue-model</i>	Sets the queuing semantics to use for queue objects.	logging
<i>fstrm-set-output-queue-size</i>	Sets the number of queue entries allocated for each output queue.	logging
<i>fstrm-set-reopen-interval</i>	Sets the number of seconds to wait between attempts to reopen a closed output stream.	logging
<i>geoip-directory</i>	Specifies the directory containing GeoIP database files.	server
<i>glue-cache</i>	Deprecated.	deprecated
<i>heartbeat-interval</i>	Sets the interval at which the server performs zone maintenance tasks for all zones marked as <i>dialup</i> .	deprecated
<i>hostname</i>	Specifies the hostname of the server to return in response to a <code>hostname.bind</code> query.	server
<i>http</i>	Configures HTTP endpoints on which to listen for DNS-over-HTTPS (DoH) queries.	server, query
<i>http-listener-clients</i>	Limits the number of active concurrent connections on a per-listener basis.	server
<i>http-port</i>	Specifies the TCP port number the server uses to receive and send unencrypted DNS traffic via HTTP.	server, query
<i>http-streams-per-connection</i>	Limits the number of active concurrent HTTP/2 streams on a per-connection basis.	server
<i>https-port</i>	Specifies the TCP port number the server uses to receive and send DNS-over-HTTPS protocol traffic.	server, query
<i>in-view</i>	Specifies the view in which a given zone is defined.	view, zone
<i>inet</i>	Specifies a TCP socket as a control channel.	server

continues on next page

Table 1 – continued from previous page

Statement	Description	Tags
<i>inline-signing</i>	Specifies whether BIND 9 maintains a separate signed version of a zone.	dnssec, zone
<i>interface-interval</i>	Sets the interval at which the server scans the network interface list.	server
<i>ipv4-prefix-length</i>	Specifies the prefix lengths of IPv4 address blocks.	server
<i>ipv4only-contact</i>	Specifies the contact for the IPV4ONLY.ARPA zone created by <i>dns64</i> .	server
<i>ipv4only-enable</i>	Enables automatic IPv4 zones if a <i>dns64</i> block is configured.	query
<i>ipv4only-server</i>	Specifies the name of the server for the IPV4ONLY.ARPA zone created by <i>dns64</i> .	server, query
<i>ipv6-prefix-length</i>	Specifies the prefix lengths of IPv6 address blocks.	server
<i>ixfr-from-differences</i>	Controls how IXFR transfers are calculated.	transfer
<i>journal</i>	Allows the default journal's filename to be overridden.	zone
<i>keep-response-order</i>	Defines an <i>address_match_list</i> of addresses which do not accept re-ordered answers within a single TCP stream.	server
<i>key</i>	Defines a shared secret key for use with <i>TSIG</i> or the command channel.	security
<i>key-directory</i>	Indicates the directory where public and private DNSSEC key files are found.	dnssec
<i>key-file</i>	Specifies the path to a file containing the private TLS key for a connection.	server, security
<i>keys</i>	Specifies one or more <i>server_key</i> s to be used with a remote server.	server, security
<i>lame-ttl</i>	Sets the resolver's lame cache.	server

continues on next page

Table 1 – continued from previous page

Statement	Description	Tags
<i>listen-on</i>	Specifies the IPv4 addresses on which a server listens for DNS queries.	server
<i>listen-on-v6</i>	Specifies the IPv6 addresses on which a server listens for DNS queries.	server
<i>listener-clients</i>	Specifies a per-listener quota for active connections.	server, query
<i>lmdb-mapsize</i>	Sets a maximum size for the memory map of the new-zone database in LMDB database format.	server
<i>lock-file</i>	Sets the pathname of the file on which <i>named</i> attempts to acquire a file lock when starting for the first time.	server
<i>log-only</i>	Tests rate-limiting parameters without actually dropping any requests.	logging, query
<i>logging</i>	Configures logging options for the name server.	logging
<i>managed-keys</i>	Deprecated, use <i>trust-anchors</i> .	deprecated
<i>managed-keys-directory</i>	Specifies the directory in which to store the files that track managed DNSSEC keys.	dnssec
<i>mapped</i>	Specifies an access control list (ACL) of IPv4 addresses that are to be mapped to the corresponding A RRset in <i>dns64</i> .	query
<i>masterfile-format</i>	Specifies the file format of zone files.	zone, server
<i>masterfile-style</i>	Specifies the format of zone files during a dump, when the <i>masterfile-format</i> is text.	server
<i>match-clients</i>	Specifies a view of DNS namespace for a given subset of client IP addresses.	view

continues on next page

Table 1 – continued from previous page

Statement	Description	Tags
<i>match-destinations</i>	Specifies a view of DNS namespace for a given subset of destination IP addresses.	view
<i>match-mapped-addresses</i>	Allows IPv4-mapped IPv6 addresses to match address-match list entries for corresponding IPv4 addresses.	server
<i>match-recursive-only</i>	Specifies that only recursive requests can match this view of the DNS namespace.	view
<i>max-cache-size</i>	Sets the maximum amount of memory to use for an individual cache database and its associated metadata.	server
<i>max-cache-ttl</i>	Specifies the maximum time (in seconds) that the server caches ordinary (positive) answers.	server
<i>max-clients-per-query</i>	Sets the maximum number of simultaneous recursive clients accepted by the server for any given query before the server drops additional clients.	server
<i>max-ixfr-ratio</i>	Sets the maximum size for IXFR responses to zone transfer requests.	transfer
<i>max-journal-size</i>	Controls the size of journal files.	transfer
<i>max-ncache-ttl</i>	Specifies the maximum retention time (in seconds) for storage of negative answers in the server's cache.	server
<i>max-query-count</i>	Sets the maximum number of iterative queries while servicing a recursive query.	server, query
<i>max-query-restarts</i>	Sets the maximum number of chained CNAMEs to follow	server, query
<i>max-records</i>	Sets the maximum number of records permitted in a zone.	zone, server
<i>max-records-per-type</i>	Sets the maximum number of records that can be stored in an RRset.	server

continues on next page

Table 1 – continued from previous page

Statement	Description	Tags
<i>max-recursion-depth</i>	Sets the maximum number of levels of recursion permitted at any one time while servicing a recursive query.	server
<i>max-recursion-queries</i>	Sets the maximum number of iterative queries while servicing a recursive query.	server, query
<i>max-refresh-time</i>	Limits the zone refresh interval to no less often than the specified value, in seconds.	transfer
<i>max-retry-time</i>	Limits the zone refresh retry interval to no less often than the specified value, in seconds.	transfer
<i>max-rsa-exponent-size</i>	Sets the maximum RSA exponent size (in bits) when validating.	dnssec, query
<i>max-stale-ttl</i>	Specifies the maximum time that the server retains records past their normal expiry, to return them as stale records.	server
<i>max-table-size</i>	Sets the maximum size of the table used to track requests and rate-limit responses.	server
<i>max-transfer-idle-in</i>	Specifies the number of minutes after which inbound zone transfers making no progress are terminated.	transfer
<i>max-transfer-idle-out</i>	Specifies the number of minutes after which outbound zone transfers making no progress are terminated.	transfer
<i>max-transfer-time-in</i>	Specifies the number of minutes after which inbound zone transfers are terminated.	transfer
<i>max-transfer-time-out</i>	Specifies the number of minutes after which outbound zone transfers are terminated.	transfer
<i>max-types-per-name</i>	Sets the maximum number of RR types that can be stored for an owner name.	server

continues on next page

Table 1 – continued from previous page

Statement	Description	Tags
<i>max-udp-size</i>	Sets the maximum EDNS UDP message size sent by <i>named</i> .	query
<i>max-zone-ttl</i>	Specifies a maximum permissible time-to-live (TTL) value, in seconds.	zone, query
<i>memstatistics</i>	Controls whether memory statistics are written to the file specified by <i>memstatistics-file</i> at exit.	server, logging
<i>memstatistics-file</i>	Sets the pathname of the file where the server writes memory usage statistics on exit.	logging
<i>message-compression</i>	Controls whether DNS name compression is used in responses to regular queries.	query
<i>min-cache-ttl</i>	Specifies the minimum time (in seconds) that the server caches ordinary (positive) answers.	server
<i>min-ncache-ttl</i>	Specifies the minimum retention time (in seconds) for storage of negative answers in the server's cache.	server
<i>min-refresh-time</i>	Limits the zone refresh interval to no more often than the specified value, in seconds.	transfer
<i>min-retry-time</i>	Limits the zone refresh retry interval to no more often than the specified value, in seconds.	transfer
<i>min-table-size</i>	Sets the minimum size of the table used to track requests and rate-limit responses.	query
<i>minimal-any</i>	Controls whether the server replies with only one of the RRsets for a query name, when generating a positive response to a query of type ANY over UDP.	query

continues on next page

Table 1 – continued from previous page

Statement	Description	Tags
<i>minimal-responses</i>	Controls whether the server only adds records to the authority and additional data sections when they are required (e.g. delegations, negative responses). This improves server performance.	query
<i>multi-master</i>	Controls whether serial number mismatch errors are logged.	transfer
<i>new-zones-directory</i>	Specifies the directory where configuration parameters are stored for zones added by <i>rndc addzone</i> .	zone
<i>no-case-compress</i>	Specifies a list of addresses that require case-insensitive compression in responses.	server
<i>nocookie-udp-size</i>	Sets the maximum size of UDP responses that are sent to queries without a valid server COOKIE.	query
<i>nodata-per-second</i>	Limits the number of empty (NO-DATA) responses for a valid domain name.	query
<i>notify</i>	Controls whether NOTIFY messages are sent on zone changes.	transfer
<i>notify-delay</i>	Sets the delay (in seconds) between sending sets of NOTIFY messages for a zone.	transfer, zone
<i>notify-rate</i>	Specifies the rate at which NOTIFY requests are sent during normal zone maintenance operations.	transfer, zone
<i>notify-source</i>	Defines the IPv4 address (and optional port) to be used for outgoing NOTIFY messages.	transfer
<i>notify-source-v6</i>	Defines the IPv6 address (and optional port) to be used for outgoing NOTIFY messages.	transfer
<i>notify-to-soa</i>	Controls whether the name servers in the NS RRset are checked against the SOA MNAME.	transfer

continues on next page

Table 1 – continued from previous page

Statement	Description	Tags
<i>nsec3param</i>	Specifies the use of NSEC3 instead of NSEC, and sets NSEC3 parameters.	dnssec
<i>nta-lifetime</i>	Specifies the lifetime, in seconds, for negative trust anchors added via <i>rndc nta</i> .	dnssec
<i>nta-recheck</i>	Specifies the time interval for checking whether negative trust anchors added via <i>rndc nta</i> are still necessary.	dnssec
<i>null</i>	Causes all messages sent to the logging channel to be discarded.	logging
<i>nxdomain-redirect</i>	Appends the specified suffix to the original query name, when replacing an NXDOMAIN with a redirect namespace.	query
<i>nxdomains-per-second</i>	Limits the number of undefined subdomains for a valid domain name.	query
<i>options</i>	Defines global options to be used by BIND 9.	server
<i>padding</i>	Adds EDNS Padding options to outgoing messages to increase the packet size.	server
<i>parent-ds-ttl</i>	Sets the time to live (TTL) of the DS RRset used by the parent zone.	dnssec
<i>parent-propagation-delay</i>	Sets the propagation delay from the time the parent zone is updated to when the new version is served by all of the parent zone's name servers.	dnssec, zone
<i>parental-agents</i>	Defines a list of delegation agents to be used by primary and secondary zones.	zone
<i>parental-source</i>	Specifies which local IPv4 source address is used to send parental DS queries.	dnssec

continues on next page

Table 1 – continued from previous page

Statement	Description	Tags
<i>parental-source-v6</i>	Specifies which local IPv6 source address is used to send parental DS queries.	dnssec
<i>pid-file</i>	Specifies the pathname of the file where the server writes its process ID.	server
<i>plugin</i>	Configures plugins in <i>named.conf</i> .	server
<i>port</i>	Specifies the UDP/TCP port number the server uses to receive and send DNS protocol traffic.	server, query
<i>prefer-server-ciphers</i>	Specifies that server ciphers should be preferred over client ones.	server, security
<i>preferred-glue</i>	Controls the order of glue records in an A or AAAA response.	query
<i>prefetch</i>	Specifies the "trigger" time-to-live (TTL) value at which prefetch of the current query takes place.	query
<i>primaries</i>	Defines one or more primary servers for a zone.	zone
<i>print-category</i>	Includes the category in log messages.	logging
<i>print-severity</i>	Includes the severity in log messages.	logging
<i>print-time</i>	Specifies the time format for log messages.	logging
<i>protocols</i>	Specifies the allowed versions of the TLS protocol.	security
<i>provide-ixfr</i>	Controls whether a primary responds to an incremental zone request (IXFR) or only responds with a full zone transfer (AXFR).	transfer
<i>publish-safety</i>	Increases the amount of time between when keys are published and when they become active, to allow for unforeseen events.	dnssec

continues on next page

Table 1 – continued from previous page

Statement	Description	Tags
<i>purge-keys</i>	Specifies the amount of time after which DNSSEC keys that have been deleted from the zone can be removed from disk.	dnssec
<i>qname-minimization</i>	Controls QNAME minimization behavior in the BIND 9 resolver.	query
<i>qps-scale</i>	Tightens defenses during DNS attacks by scaling back the ratio of the current query-per-second rate.	query
<i>query-source</i>	Controls the IPv4 address from which queries are issued.	query
<i>query-source-v6</i>	Controls the IPv6 address from which queries are issued.	query
<i>querylog</i>	Specifies whether query logging should be active when <i>named</i> first starts.	logging, server
<i>rate-limit</i>	Controls excessive UDP responses, to prevent BIND 9 from being used to amplify reflection denial-of-service (DoS) attacks.	query
<i>recursing-file</i>	Specifies the pathname of the file where the server dumps queries that are currently recursing via <i>rndc recursing</i> .	server
<i>recursion</i>	Defines whether recursion and caching are allowed.	query
<i>recursive-clients</i>	Specifies the maximum number of concurrent recursive queries the server can perform.	query
<i>recursive-only</i>	Toggles whether <i>dns64</i> synthesis occurs only for recursive queries.	query
<i>referrals-per-second</i>	Limits the number of referrals or delegations to a server for a given domain.	query
<i>remote-hostname</i>	Specifies the expected hostname in the TLS certificate of the remote server.	security

continues on next page

Table 1 – continued from previous page

Statement	Description	Tags
<i>request-expire</i>	Specifies whether the local server requests the EDNS EXPIRE value, when acting as a secondary.	transfer, query
<i>request-ixfr</i>	Controls whether a secondary requests an incremental zone transfer (IXFR) or a full zone transfer (AXFR).	transfer
<i>request-nsid</i>	Controls whether an empty EDNS(0) NSID (Name Server Identifier) option is sent with all queries to authoritative name servers during iterative resolution.	query
<i>require-server-cookie</i>	Controls whether a valid server cookie is required before sending a full response to a UDP request.	query
<i>reserved-sockets</i>	Deprecated.	deprecated
<i>resolver-nonbackoff-tries</i>	Specifies the number of retries before exponential backoff.	deprecated.
<i>resolver-query-timeout</i>	Specifies the length of time, in milliseconds, that a resolver attempts to resolve a recursive query before failing.	query
<i>resolver-retry-interval</i>	Sets the base retry interval (in milliseconds).	deprecated
<i>response-padding</i>	Adds an EDNS Padding option to encrypted messages, to reduce the chance of guessing the contents based on size.	query
<i>response-policy</i>	Specifies response policy zones for the view or among global options.	server, query, zone, security
<i>responses-per-second</i>	Limits the number of non-empty responses for a valid domain name and record type.	query
<i>retire-safety</i>	Increases the amount of time a key remains published after it is no longer active, to allow for unforeseen events.	dnssec

continues on next page

Table 1 – continued from previous page

Statement	Description	Tags
<i>reuseport</i>	Enables kernel load-balancing of sockets.	server
<i>root-delegation-only</i>	Turns on enforcement of delegation-only in top-level domains (TLDs) and root zones with an optional exclude list.	deprecated
<i>root-key-sentinel</i>	Controls whether BIND 9 responds to root key sentinel probes.	server
<i>rrset-order</i>	Defines the order in which equal RRs (RRsets) are returned.	query
<i>search</i>	Specifies whether a Dynamically Loadable Zone (DLZ) module is queried for an answer to a query name.	query
<i>secret</i>	Defines a Base64-encoded string to be used as the secret by the algorithm.	security
<i>secroots-file</i>	Specifies the pathname of the file where the server dumps security roots, when using <i>rndc secroots</i> .	dnssec
<i>send-cookie</i>	Controls whether a COOKIE EDNS option is sent along with a query.	query
<i>serial-query-rate</i>	Defines an upper limit on the number of queries per second issued by the server, when querying the SOA RRs used for zone transfers.	transfer
<i>serial-update-method</i>	Specifies the update method to be used for the zone serial number in the SOA record.	zone
<i>server</i>	Defines characteristics to be associated with a remote name server.	server
<i>server-addresses</i>	Specifies a list of IP addresses to which queries should be sent in recursive resolution for a static-stub zone.	query, zone
<i>server-id</i>	Specifies the ID of the server to return in response to a <code>ID.SERVER</code> query.	server

continues on next page

Table 1 – continued from previous page

Statement	Description	Tags
<i>server-names</i>	Specifies a list of domain names of name servers that act as authoritative servers of a static-stub zone.	zone
<i>servfail-ttl</i>	Sets the length of time (in seconds) that a SERVFAIL response is cached.	server
<i>session-keyalg</i>	Specifies the algorithm to use for the TSIG session key.	security
<i>session-keyfile</i>	Specifies the pathname of the file where a TSIG session key is written, when generated by <i>named</i> for use by <i>nsupdate -l</i> .	security
<i>session-keyname</i>	Specifies the key name for the TSIG session key.	security
<i>session-tickets</i>	Enables or disables session resumption through TLS session tickets.	security
<i>severity</i>	Defines the priority level of log messages.	logging
<i>sig-signing-nodes</i>	Specifies the maximum number of nodes to be examined in each quantum, when signing a zone with a new DNSKEY.	dnssec
<i>sig-signing-signatures</i>	Specifies the threshold for the number of signatures that terminates processing a quantum, when signing a zone with a new DNSKEY.	dnssec
<i>sig-signing-type</i>	Specifies a private RDATA type to use when generating signing-state records.	dnssec
<i>sig-validity-interval</i>	Specifies the maximum number of days that RRSIGs generated by <i>named</i> are valid.	dnssec
<i>signatures-jitter</i>	Specifies a range for signature expirations.	dnssec
<i>signatures-refresh</i>	Specifies how frequently an RRSIG record is refreshed.	dnssec

continues on next page

Table 1 – continued from previous page

Statement	Description	Tags
<i>signatures-validity</i>	Indicates the validity period of an RRSIG record.	dnssec
<i>signatures-validity-dnskey</i>	Indicates the validity period of DNSKEY records.	dnssec
<i>slip</i>	Sets the number of "slipped" responses to minimize the use of forged source addresses for an attack.	query
<i>sortlist</i>	Controls the ordering of RRs returned to the client, based on the client's IP address.	query
<i>stacksize</i>	Sets the maximum amount of stack memory that can be used by the server.	deprecated
<i>stale-answer-client-timeout</i>	Defines the amount of time (in milliseconds) that <i>named</i> waits before attempting to answer a query with a stale RRset from cache.	server, query
<i>stale-answer-enable</i>	Enables the returning of "stale" cached answers when the name servers for a zone are not answering.	server, query
<i>stale-answer-ttl</i>	Specifies the time to live (TTL) to be returned on stale answers, in seconds.	query
<i>stale-cache-enable</i>	Enables the retention of "stale" cached answers.	server, query
<i>stale-refresh-time</i>	Sets the time window for the return of "stale" cached answers before the next attempt to contact, if the name servers for a given zone are not responding.	server, query
<i>startup-notify-rate</i>	Specifies the rate at which NOTIFY requests are sent when the name server is first starting, or when new zones have been added.	transfer, zone
<i>statistics-channels</i>	Specifies the communication channels to be used by system administrators to access statistics information on the name server.	logging

continues on next page

Table 1 – continued from previous page

Statement	Description	Tags
<i>statistics-file</i>	Specifies the pathname of the file where the server appends statistics, when using <i>rndc stats</i> .	logging, server
<i>stderr</i>	Directs the logging channel output to the server's standard error stream.	logging
<i>streams-per-connection</i>	Specifies the maximum number of concurrent HTTP/2 streams over an HTTP/2 connection.	server, query
<i>suffix</i>	Defines trailing bits for mapped IPv4 address bits in <i>dns64</i> .	query
<i>synth-from-dnssec</i>	Enables support for <b>RFC 8198</b> , Aggressive Use of DNSSEC-Validated Cache.	dnssec
<i>syslog</i>	Directs the logging channel to the system log.	logging
<i>tcp-advertised-timeout</i>	Sets the timeout value (in milliseconds) that the server sends in responses containing the EDNS TCP keepalive option.	query
<i>tcp-clients</i>	Specifies the maximum number of simultaneous client TCP connections accepted by the server.	server
<i>tcp-idle-timeout</i>	Sets the amount of time (in milliseconds) that the server waits on an idle TCP connection before closing it, if the EDNS TCP keepalive option is not in use.	query
<i>tcp-initial-timeout</i>	Sets the amount of time (in milliseconds) that the server waits on a new TCP connection for the first message from the client.	server, query
<i>tcp-keepalive</i>	Adds EDNS TCP keepalive to messages sent over TCP.	server
<i>tcp-keepalive-timeout</i>	Sets the amount of time (in milliseconds) that the server waits on an idle TCP connection before closing it, if the EDNS TCP keepalive option is in use.	query

continues on next page

Table 1 – continued from previous page

Statement	Description	Tags
<i>tcp-listen-queue</i>	Sets the listen-queue depth.	server
<i>tcp-only</i>	Sets the transport protocol to TCP.	server
<i>tcp-receive-buffer</i>	Sets the operating system's receive buffer size for TCP sockets.	server
<i>tcp-send-buffer</i>	Sets the operating system's send buffer size for TCP sockets.	server
<i>tkey-dhkey</i>	Sets the Diffie-Hellman key used by the server to generate shared keys.	deprecated
<i>tkey-domain</i>	Sets the domain appended to the names of all shared keys generated with TKEY.	security
<i>tkey-gssapi-credential</i>	Sets the security credential for authentication keys requested by the GSS-TSIG protocol.	security
<i>tkey-gssapi-keytab</i>	Sets the KRB5 keytab file to use for GSS-TSIG updates.	security
<i>tls</i>	Configures a TLS connection.	security
<i>tls-port</i>	Specifies the TCP port number the server uses to receive and send DNS-over-TLS protocol traffic.	server, query
<i>transfer-format</i>	Controls whether multiple records can be packed into a message during zone transfers.	transfer
<i>transfer-message-size</i>	Limits the uncompressed size of DNS messages used in zone transfers over TCP.	transfer
<i>transfer-source</i>	Defines which local IPv4 address(es) are bound to TCP connections used to fetch zones transferred inbound by the server.	transfer
<i>transfer-source-v6</i>	Defines which local IPv6 address(es) are bound to TCP connections used to fetch zones transferred inbound by the server.	transfer

continues on next page

Table 1 – continued from previous page

Statement	Description	Tags
<i>transfers</i>	Limits the number of concurrent inbound zone transfers from a server.	server
<i>transfers-in</i>	Limits the number of concurrent inbound zone transfers.	transfer
<i>transfers-out</i>	Limits the number of concurrent outbound zone transfers.	transfer
<i>transfers-per-ns</i>	Limits the number of concurrent inbound zone transfers from a remote server.	transfer
<i>trust-anchor-telemetry</i>	Instructs <i>named</i> to send specially formed queries once per day to domains for which trust anchors have been configured.	dnssec
<i>trust-anchors</i>	Defines <i>DNSSEC</i> trust anchors.	dnssec
<i>trusted-keys</i>	Deprecated, use <i>trust-anchors</i> .	deprecated
<i>try-tcp-refresh</i>	Specifies that BIND 9 should attempt to refresh a zone using TCP if UDP queries fail.	transfer
<i>type</i>	Specifies the kind of zone in a given configuration.	zone
<i>type delegation-only</i>	Enforces the delegation-only status of infrastructure zones (COM, NET, ORG, etc.).	deprecated
<i>type forward</i>	Contains forwarding statements that apply to queries within a given domain.	zone
<i>type hint</i>	Contains the initial set of root name servers to be used at BIND 9 startup.	zone
<i>type mirror</i>	Contains a DNSSEC-validated duplicate of the main data for a zone.	zone
<i>type primary</i>	Contains the main copy of the data for a zone.	zone
<i>type redirect</i>	Contains information to answer queries when normal resolution would return NXDOMAIN.	zone

continues on next page

Table 1 – continued from previous page

Statement	Description	Tags
<i>type secondary</i>	Contains a duplicate of the data for a zone that has been transferred from a primary server.	zone
<i>type static-stub</i>	Contains statically configured NS records for a zone.	zone
<i>type stub</i>	Contains a duplicate of the NS records of a zone.	zone
<i>udp-recv-buffer</i>	Sets the operating system's receive buffer size for UDP sockets.	server
<i>udp-send-buffer</i>	Sets the operating system's send buffer size for UDP sockets.	server
<i>unix</i>	Specifies a Unix domain socket as a control channel.	server
<i>update-check-ksk</i>	Specifies whether to check the KSK bit to determine how a key should be used, when generating RRSIGs for a secure zone.	zone, dnssec
<i>update-policy</i>	Sets fine-grained rules to allow or deny dynamic updates (DDNS), based on requester identity, updated content, etc.	transfer
<i>update-quota</i>	Specifies the maximum number of concurrent DNS UPDATE messages that can be processed by the server.	server
<i>use-alt-transfer-source</i>	Indicates whether <i>alt-transfer-source</i> and <i>alt-transfer-source-v6</i> can be used.	deprecated
<i>use-v4-udp-ports</i>	Specifies a list of ports that are valid sources for UDP/IPv4 messages.	deprecated
<i>use-v6-udp-ports</i>	Specifies a list of ports that are valid sources for UDP/IPv6 messages.	deprecated
<i>v6-bias</i>	Indicates the number of milliseconds of preference to give to IPv6 name servers.	server, query

continues on next page

Table 1 – continued from previous page

Statement	Description	Tags
<i>validate-except</i>	Specifies a list of domain names at and beneath which DNSSEC validation should not be performed.	dnssec
<i>version</i>	Specifies the version number of the server to return in response to a <code>version.bind</code> query.	server
<i>view</i>	Allows a name server to answer a DNS query differently depending on who is asking.	view
<i>window</i>	Specifies the length of time during which responses are tracked.	query
<i>zero-no-soa-ttl</i>	Specifies whether to set the time to live (TTL) of the SOA record to zero, when returning authoritative negative responses to SOA queries.	zone, query, server
<i>zero-no-soa-ttl-cache</i>	Sets the time to live (TTL) to zero when caching a negative response to an SOA query.	zone, query, server
<i>zone</i>	Specifies the zone in a BIND 9 configuration.	zone
<i>zone-propagation-delay</i>	Sets the propagation delay from the time a zone is first updated to when the new version of the zone is served by all secondary servers.	dnssec, zone
<i>zone-statistics</i>	Controls the level of statistics gathered for all zones.	zone, logging

## 8.4 Statements by Tag

These tables group the various statements permissible in `named.conf` by their corresponding tag.

### 8.4.1 DNSSEC Tag Statements

Statement	Description
<i>auto-dnssec</i>	Permits varying levels of automatic DNSSEC key management.

continues on next page

Table 2 – continued from previous page

Statement	Description
<i>bindkeys-file</i>	Specifies the pathname of a file to override the built-in trusted keys provided by <i>named</i> .
<i>check-dup-records</i>	Checks primary zones for records that are treated as different by DNSSEC but are semantically equal in plain DNS.
<i>disable-algorithms</i>	Disables DNSSEC algorithms from a specified zone.
<i>disable-ds-digests</i>	Disables DS digest types from a specified zone.
<i>dnskey-sig-validity</i>	Specifies the number of days in the future when automatically generated DNSSEC signatures expire.
<i>dnskey-ttl</i>	Specifies the time to live (TTL) for DNSKEY resource records.
<i>dnssec-accept-expired</i>	Instructs BIND 9 to accept expired DNSSEC signatures when validating.
<i>dnssec-dnskey-kskonly</i>	Specifies that only key-signing keys are used to sign the DNSKEY, CDNSKEY, and CDS RRsets at a zone's apex.
<i>dnssec-loadkeys-interval</i>	Sets the frequency of automatic checks of the DNSSEC key repository.
<i>dnssec-policy</i>	Defines a key and signing policy (KASP) for zones.
<i>dnssec-secure-to-insecure</i>	Allows a dynamic zone to transition from secure to insecure by deleting all DNSKEY records.
<i>dnssec-update-mode</i>	Controls the scheduled maintenance of DNSSEC signatures.
<i>dnssec-validation</i>	Enables DNSSEC validation in <i>named</i> .
<i>inline-signing</i>	Specifies whether BIND 9 maintains a separate signed version of a zone.
<i>key-directory</i>	Indicates the directory where public and private DNSSEC key files are found.
<i>managed-keys-directory</i>	Specifies the directory in which to store the files that track managed DNSSEC keys.
<i>max-rsa-exponent-size</i>	Sets the maximum RSA exponent size (in bits) when validating.

continues on next page

Table 2 – continued from previous page

Statement	Description
<i>nsec3param</i>	Specifies the use of NSEC3 instead of NSEC, and sets NSEC3 parameters.
<i>nta-lifetime</i>	Specifies the lifetime, in seconds, for negative trust anchors added via <i>rndc nta</i> .
<i>nta-recheck</i>	Specifies the time interval for checking whether negative trust anchors added via <i>rndc nta</i> are still necessary.
<i>parent-ds-ttl</i>	Sets the time to live (TTL) of the DS RRset used by the parent zone.
<i>parent-propagation-delay</i>	Sets the propagation delay from the time the parent zone is updated to when the new version is served by all of the parent zone's name servers.
<i>parental-source</i>	Specifies which local IPv4 source address is used to send parental DS queries.
<i>parental-source-v6</i>	Specifies which local IPv6 source address is used to send parental DS queries.
<i>publish-safety</i>	Increases the amount of time between when keys are published and when they become active, to allow for unforeseen events.
<i>purge-keys</i>	Specifies the amount of time after which DNSSEC keys that have been deleted from the zone can be removed from disk.
<i>retire-safety</i>	Increases the amount of time a key remains published after it is no longer active, to allow for unforeseen events.
<i>secroots-file</i>	Specifies the pathname of the file where the server dumps security roots, when using <i>rndc secroots</i> .
<i>sig-signing-nodes</i>	Specifies the maximum number of nodes to be examined in each quantum, when signing a zone with a new DNSKEY.
<i>sig-signing-signatures</i>	Specifies the threshold for the number of signatures that terminates processing a quantum, when signing a zone with a new DNSKEY.
<i>sig-signing-type</i>	Specifies a private RDATA type to use when generating signing-state records.
<i>sig-validity-interval</i>	Specifies the maximum number of days that RRSIGs generated by <i>named</i> are valid.

continues on next page

Table 2 – continued from previous page

Statement	Description
<i>signatures-jitter</i>	Specifies a range for signature expirations.
<i>signatures-refresh</i>	Specifies how frequently an RRSIG record is refreshed.
<i>signatures-validity</i>	Indicates the validity period of an RRSIG record.
<i>signatures-validity-dnskey</i>	Indicates the validity period of DNSKEY records.
<i>synth-from-dnssec</i>	Enables support for <b>RFC 8198</b> , Aggressive Use of DNSSEC-Validated Cache.
<i>trust-anchor-telemetry</i>	Instructs <i>named</i> to send specially formed queries once per day to domains for which trust anchors have been configured.
<i>trust-anchors</i>	Defines <i>DNSSEC</i> trust anchors.
<i>update-check-ksk</i>	Specifies whether to check the KSK bit to determine how a key should be used, when generating RRSIGs for a secure zone.
<i>validate-exception</i>	Specifies a list of domain names at and beneath which DNSSEC validation should not be performed.
<i>zone-propagation-delay</i>	Sets the propagation delay from the time a zone is first updated to when the new version of the zone is served by all secondary servers.

## 8.4.2 Logging Tag Statements

Statement	Description
<i>buffered</i>	Controls flushing of log messages.
<i>category</i>	Specifies the type of data logged to a particular channel.
<i>channel</i>	Defines a stream of data that can be independently logged.
<i>dnstap</i>	Enables logging of <i>dnstap</i> messages.
<i>dnstap-identity</i>	Specifies an <i>identity</i> string to send in <i>dnstap</i> messages.
<i>dnstap-output</i>	Configures the path to which the <i>dnstap</i> frame stream is sent.
<i>dnstap-version</i>	Specifies a <i>version</i> string to send in <i>dnstap</i> messages.

continues on next page

Table 3 – continued from previous page

Statement	Description
<i>dump-file</i>	Indicates the pathname of the file where the server dumps the database after <i>rndc dumpdb</i> .
<i>fstrm-set-buffer-hint</i>	Sets the number of accumulated bytes in the output buffer before forcing a buffer flush.
<i>fstrm-set-flush-timeout</i>	Sets the number of seconds that unflushed data remains in the output buffer.
<i>fstrm-set-input-queue-size</i>	Sets the number of queue entries to allocate for each input queue.
<i>fstrm-set-output-notify-threshold</i>	Sets the number of outstanding queue entries allowed on an input queue before waking the I/O thread.
<i>fstrm-set-output-queue-model</i>	Sets the queuing semantics to use for queue objects.
<i>fstrm-set-output-queue-size</i>	Sets the number of queue entries allocated for each output queue.
<i>fstrm-set-reopen-interval</i>	Sets the number of seconds to wait between attempts to reopen a closed output stream.
<i>log-only</i>	Tests rate-limiting parameters without actually dropping any requests.
<i>logging</i>	Configures logging options for the name server.
<i>memstatistics</i>	Controls whether memory statistics are written to the file specified by <i>memstatistics-file</i> at exit.
<i>memstatistics-file</i>	Sets the pathname of the file where the server writes memory usage statistics on exit.
<i>null</i>	Causes all messages sent to the logging channel to be discarded.
<i>print-category</i>	Includes the category in log messages.
<i>print-severity</i>	Includes the severity in log messages.
<i>print-time</i>	Specifies the time format for log messages.
<i>querylog</i>	Specifies whether query logging should be active when <i>named</i> first starts.
<i>severity</i>	Defines the priority level of log messages.

continues on next page

Table 3 – continued from previous page

Statement	Description
<i>statistics-channels</i>	Specifies the communication channels to be used by system administrators to access statistics information on the name server.
<i>statistics-file</i>	Specifies the pathname of the file where the server appends statistics, when using <i>rndc stats</i> .
<i>stderr</i>	Directs the logging channel output to the server's standard error stream.
<i>syslog</i>	Directs the logging channel to the system log.
<i>zone-statistics</i>	Controls the level of statistics gathered for all zones.

### 8.4.3 Query Tag Statements

Statement	Description
<i>all-per-second</i>	Limits UDP responses of all kinds.
<i>allow-query</i>	Specifies which hosts (an IP address list) are allowed to send queries to this resolver.
<i>allow-query-cache</i>	Specifies which hosts (an IP address list) can access this server's cache and thus effectively controls recursion.
<i>allow-query-cache-on</i>	Specifies which hosts (an IP address list) can access this server's cache. Used on servers with multiple interfaces.
<i>allow-query-on</i>	Specifies which local addresses (an IP address list) are allowed to send queries to this resolver. Used in multi-homed configurations.
<i>allow-recursion</i>	Defines an <i>address_match_list</i> of clients that are allowed to perform recursive queries.
<i>allow-recursion-on</i>	Specifies which local addresses can accept recursive queries.
<i>answer-cookie</i>	Controls whether COOKIE EDNS replies are sent in response to client queries.
<i>auth-nxdomain</i>	Controls whether BIND, acting as a resolver, provides authoritative NXDOMAIN (domain does not exist) answers.

continues on next page

Table 4 – continued from previous page

Statement	Description
<i>blackhole</i>	Defines an <i>address_match_list</i> of hosts to ignore. The server will neither respond to queries from nor send queries to these addresses.
<i>break-dnssec</i>	Enables <i>dns64</i> synthesis even if the validated result would cause a DNSSEC validation failure.
<i>check-dup-records</i>	Checks primary zones for records that are treated as different by DNSSEC but are semantically equal in plain DNS.
<i>check-names</i>	Restricts the character set and syntax of certain domain names in primary files and/or DNS responses received from the network.
<i>clients</i>	Specifies an access control list (ACL) of clients that are affected by a given <i>dns64</i> directive.
<i>deny-answer-addresses</i>	Rejects A or AAAA records if the corresponding IPv4 or IPv6 addresses match a given <i>address_match_list</i> .
<i>deny-answer-aliases</i>	Rejects CNAME or DNAME records if the "alias" name matches a given list of <i>domain_name</i> elements.
<i>dns64</i>	Instructs <i>named</i> to return mapped IPv4 addresses to AAAA queries when there are no AAAA records.
<i>dscp</i>	Sets the Differentiated Services Code Point (DSCP) value (obsolete).
<i>edns-udp-size</i>	Sets the maximum advertised EDNS UDP buffer size to control the size of packets received from authoritative servers in response to recursive queries.
<i>endpoints</i>	Specifies a list of HTTP query paths on which to listen.
<i>exclude</i>	Allows a list of IPv6 addresses to be ignored if they appear in a domain name's AAAA records in <i>dns64</i> .
<i>exempt-clients</i>	Exempts specific clients or client groups from rate limiting.
<i>fetch-quota-params</i>	Sets the parameters for dynamic resizing of the <i>fetches-per-server</i> quota in response to detected congestion.
<i>fetches-per-server</i>	Sets the maximum number of simultaneous iterative queries allowed to be sent by a server to an upstream name server before the server blocks additional queries.

continues on next page

Table 4 – continued from previous page

Statement	Description
<i>fetches-per-zone</i>	Sets the maximum number of simultaneous iterative queries allowed to any one domain before the server blocks new queries for data in or beneath that zone.
<i>forward</i>	Allows or disallows fallback to recursion if forwarding has failed; it is always used in conjunction with the <i>forwarders</i> statement.
<i>forwarders</i>	Defines one or more resolvers to which queries are forwarded.
<i>http</i>	Configures HTTP endpoints on which to listen for DNS-over-HTTPS (DoH) queries.
<i>http-port</i>	Specifies the TCP port number the server uses to receive and send unencrypted DNS traffic via HTTP.
<i>https-port</i>	Specifies the TCP port number the server uses to receive and send DNS-over-HTTPS protocol traffic.
<i>ipv4only-enable</i>	Enables automatic IPv4 zones if a <i>dns64</i> block is configured.
<i>ipv4only-server</i>	Specifies the name of the server for the IPV4ONLY.ARPA zone created by <i>dns64</i> .
<i>listener-clients</i>	Specifies a per-listener quota for active connections.
<i>log-only</i>	Tests rate-limiting parameters without actually dropping any requests.
<i>mapped</i>	Specifies an access control list (ACL) of IPv4 addresses that are to be mapped to the corresponding A RRset in <i>dns64</i> .
<i>max-query-count</i>	Sets the maximum number of iterative queries while servicing a recursive query.
<i>max-query-restarts</i>	Sets the maximum number of chained CNAMEs to follow
<i>max-recursion-queries</i>	Sets the maximum number of iterative queries while servicing a recursive query.
<i>max-rsa-exponent-size</i>	Sets the maximum RSA exponent size (in bits) when validating.
<i>max-udp-size</i>	Sets the maximum EDNS UDP message size sent by <i>named</i> .

continues on next page

Table 4 – continued from previous page

Statement	Description
<i>max-zone-ttl</i>	Specifies a maximum permissible time-to-live (TTL) value, in seconds.
<i>message-compression</i>	Controls whether DNS name compression is used in responses to regular queries.
<i>min-table-size</i>	Sets the minimum size of the table used to track requests and rate-limit responses.
<i>minimal-any</i>	Controls whether the server replies with only one of the RRsets for a query name, when generating a positive response to a query of type ANY over UDP.
<i>minimal-responses</i>	Controls whether the server only adds records to the authority and additional data sections when they are required (e.g. delegations, negative responses). This improves server performance.
<i>nocookie-udp-size</i>	Sets the maximum size of UDP responses that are sent to queries without a valid server COOKIE.
<i>nodata-per-second</i>	Limits the number of empty (NODATA) responses for a valid domain name.
<i>nxdomain-redirect</i>	Appends the specified suffix to the original query name, when replacing an NXDOMAIN with a redirect namespace.
<i>nxdomains-per-second</i>	Limits the number of undefined subdomains for a valid domain name.
<i>port</i>	Specifies the UDP/TCP port number the server uses to receive and send DNS protocol traffic.
<i>preferred-glue</i>	Controls the order of glue records in an A or AAAA response.
<i>prefetch</i>	Specifies the "trigger" time-to-live (TTL) value at which prefetch of the current query takes place.
<i>qname-minimization</i>	Controls QNAME minimization behavior in the BIND 9 resolver.
<i>qps-scale</i>	Tightens defenses during DNS attacks by scaling back the ratio of the current query-per-second rate.
<i>query-source</i>	Controls the IPv4 address from which queries are issued.
<i>query-source-v6</i>	Controls the IPv6 address from which queries are issued.

continues on next page

Table 4 – continued from previous page

Statement	Description
<i>rate-limit</i>	Controls excessive UDP responses, to prevent BIND 9 from being used to amplify reflection denial-of-service (DoS) attacks.
<i>recursion</i>	Defines whether recursion and caching are allowed.
<i>recursive-clients</i>	Specifies the maximum number of concurrent recursive queries the server can perform.
<i>recursive-only</i>	Toggles whether <i>dns64</i> synthesis occurs only for recursive queries.
<i>referrals-per-second</i>	Limits the number of referrals or delegations to a server for a given domain.
<i>request-expire</i>	Specifies whether the local server requests the EDNS EXPIRE value, when acting as a secondary.
<i>request-nsid</i>	Controls whether an empty EDNS(0) NSID (Name Server Identifier) option is sent with all queries to authoritative name servers during iterative resolution.
<i>require-server-cookie</i>	Controls whether a valid server cookie is required before sending a full response to a UDP request.
<i>resolver-query-timeout</i>	Specifies the length of time, in milliseconds, that a resolver attempts to resolve a recursive query before failing.
<i>response-padding</i>	Adds an EDNS Padding option to encrypted messages, to reduce the chance of guessing the contents based on size.
<i>response-policy</i>	Specifies response policy zones for the view or among global options.
<i>responses-per-second</i>	Limits the number of non-empty responses for a valid domain name and record type.
<i>rrset-order</i>	Defines the order in which equal RRs (RRsets) are returned.
<i>search</i>	Specifies whether a Dynamically Loadable Zone (DLZ) module is queried for an answer to a query name.
<i>send-cookie</i>	Controls whether a COOKIE EDNS option is sent along with a query.
<i>server-addresses</i>	Specifies a list of IP addresses to which queries should be sent in recursive resolution for a static-stub zone.

continues on next page

Table 4 – continued from previous page

Statement	Description
<i>slip</i>	Sets the number of "slipped" responses to minimize the use of forged source addresses for an attack.
<i>sortlist</i>	Controls the ordering of RRs returned to the client, based on the client's IP address.
<i>stale-answer-client-timeout</i>	Defines the amount of time (in milliseconds) that <i>named</i> waits before attempting to answer a query with a stale RRset from cache.
<i>stale-answer-enable</i>	Enables the returning of "stale" cached answers when the name servers for a zone are not answering.
<i>stale-answer-ttl</i>	Specifies the time to live (TTL) to be returned on stale answers, in seconds.
<i>stale-cache-enable</i>	Enables the retention of "stale" cached answers.
<i>stale-refresh-time</i>	Sets the time window for the return of "stale" cached answers before the next attempt to contact, if the name servers for a given zone are not responding.
<i>streams-per-connection</i>	Specifies the maximum number of concurrent HTTP/2 streams over an HTTP/2 connection.
<i>suffix</i>	Defines trailing bits for mapped IPv4 address bits in <i>dns64</i> .
<i>tcp-advertised-timeout</i>	Sets the timeout value (in milliseconds) that the server sends in responses containing the EDNS TCP keepalive option.
<i>tcp-idle-timeout</i>	Sets the amount of time (in milliseconds) that the server waits on an idle TCP connection before closing it, if the EDNS TCP keepalive option is not in use.
<i>tcp-initial-timeout</i>	Sets the amount of time (in milliseconds) that the server waits on a new TCP connection for the first message from the client.
<i>tcp-keepalive-timeout</i>	Sets the amount of time (in milliseconds) that the server waits on an idle TCP connection before closing it, if the EDNS TCP keepalive option is in use.
<i>tls-port</i>	Specifies the TCP port number the server uses to receive and send DNS-over-TLS protocol traffic.
<i>v6-bias</i>	Indicates the number of milliseconds of preference to give to IPv6 name servers.

continues on next page

Table 4 – continued from previous page

Statement	Description
<i>window</i>	Specifies the length of time during which responses are tracked.
<i>zero-no-soa-ttl</i>	Specifies whether to set the time to live (TTL) of the SOA record to zero, when returning authoritative negative responses to SOA queries.
<i>zero-no-soa-ttl-cache</i>	Sets the time to live (TTL) to zero when caching a negative response to an SOA query.

## 8.4.4 Security Tag Statements

Statement	Description
<i>algorithm</i>	Defines the algorithm to be used in a key clause.
<i>ca-file</i>	Specifies the path to a file containing TLS certificates for trusted CA authorities, used to verify remote peer certificates.
<i>cert-file</i>	Specifies the path to a file containing the TLS certificate for a connection.
<i>ciphers</i>	Specifies a list of allowed ciphers.
<i>dhparam-file</i>	Specifies the path to a file containing Diffie-Hellman parameters, for enabling cipher suites.
<i>dnsrps-enable</i>	Turns on the DNS Response Policy Service (DNSRPS) interface.
<i>dnsrps-options</i>	Provides additional RPZ configuration settings, which are passed to the DNS Response Policy Service (DNSRPS) provider library.
<i>key</i>	Defines a shared secret key for use with <i>TSIG</i> or the command channel.
<i>key-file</i>	Specifies the path to a file containing the private TLS key for a connection.
<i>keys</i>	Specifies one or more <i>server_key</i> s to be used with a remote server.
<i>prefer-server-ciphers</i>	Specifies that server ciphers should be preferred over client ones.
<i>protocols</i>	Specifies the allowed versions of the TLS protocol.
<i>remote-hostname</i>	Specifies the expected hostname in the TLS certificate of the remote server.
<i>response-policy</i>	Specifies response policy zones for the view or among global options.
<i>secret</i>	Defines a Base64-encoded string to be used as the secret by the algorithm.
<i>session-keyalg</i>	Specifies the algorithm to use for the TSIG session key.
<i>session-keyfile</i>	Specifies the pathname of the file where a TSIG session key is written, when generated by <i>named</i> for use by <i>nsupdate -l</i> .
<i>session-keyname</i>	Specifies the key name for the TSIG session key.
<i>session-tickets</i>	Enables or disables session resumption through TLS session tickets.
<i>tkey-domain</i>	Sets the domain appended to the names of all shared keys generated with <i>TKEY</i> .
<i>tkey-gssapi-credential</i>	Sets the security credential for authentication keys requested by the GSS-TSIG protocol.
<i>tkey-gssapi-keytab</i>	Sets the KRB5 keytab file to use for GSS-TSIG updates.
<i>tls</i>	Configures a TLS connection.

### 8.4.5 Server Tag Statements

Statement	Description
<i>acl</i>	Assigns a symbolic name to an address match list.
<i>allow-new-zones</i>	Controls the ability to add zones at runtime via <i>rndc addzone</i> .
<i>allow-recursion-on</i>	Specifies which local addresses can accept recursive queries.
<i>automatic-interface-scan</i>	Controls the automatic rescanning of network interfaces when addresses are added or removed.
<i>bogus</i>	Allows a remote server to be ignored.
<i>ca-file</i>	Specifies the path to a file containing TLS certificates for trusted CA authorities, used to verify remote peer certificates.
<i>cert-file</i>	Specifies the path to a file containing the TLS certificate for a connection.
<i>check-names</i>	Restricts the character set and syntax of certain domain names in primary files and/or DNS responses received from the network.
<i>clients-per-query</i>	Sets the initial minimum number of simultaneous recursive clients accepted by the server for any given query before the server drops additional clients.
<i>controls</i>	Specifies control channels to be used to manage the name server.
<i>cookie-algorithm</i>	Sets the algorithm to be used when generating a server cookie.
<i>cookie-secret</i>	Specifies a shared secret used for generating and verifying EDNS COOKIE options within an anycast cluster.
<i>dhparam-file</i>	Specifies the path to a file containing Diffie-Hellman parameters, for enabling cipher suites.
<i>directory</i>	Sets the server's working directory.
<i>disable-empty-zone</i>	Disables individual empty zones.
<i>dns64-contact</i>	Specifies the name of the contact for <i>dns64</i> zones.
<i>dns64-server</i>	Specifies the name of the server for <i>dns64</i> zones.

continues on next page

Table 5 – continued from previous page

Statement	Description
<i>dnssrps-enable</i>	Turns on the DNS Response Policy Service (DNSRPS) interface.
<i>dnssrps-options</i>	Provides additional RPZ configuration settings, which are passed to the DNS Response Policy Service (DNSRPS) provider library.
<i>dscp</i>	Sets the Differentiated Services Code Point (DSCP) value (obsolete).
<i>dual-stack-servers</i>	Specifies host names or addresses of machines with access to both IPv4 and IPv6 transports.
<i>edns</i>	Controls the use of the EDNS0 ( <a href="#">RFC 2671</a> ) feature.
<i>edns-version</i>	Sets the maximum EDNS VERSION that is sent to the server(s) by the resolver.
<i>empty-contact</i>	Specifies the contact name in the returned SOA record for empty zones.
<i>empty-server</i>	Specifies the server name in the returned SOA record for empty zones.
<i>empty-zones-enable</i>	Enables or disables all empty zones.
<i>endpoints</i>	Specifies a list of HTTP query paths on which to listen.
<i>errors-per-second</i>	Limits the number of errors for a valid domain name and record type.
<i>fetch-quota-params</i>	Sets the parameters for dynamic resizing of the <i>fetches-per-server</i> quota in response to detected congestion.
<i>fetches-per-server</i>	Sets the maximum number of simultaneous iterative queries allowed to be sent by a server to an upstream name server before the server blocks additional queries.
<i>fetches-per-zone</i>	Sets the maximum number of simultaneous iterative queries allowed to any one domain before the server blocks new queries for data in or beneath that zone.
<i>geoip-directory</i>	Specifies the directory containing GeoIP database files.
<i>hostname</i>	Specifies the hostname of the server to return in response to a <code>hostname.bind</code> query.

continues on next page

Table 5 – continued from previous page

Statement	Description
<i>http</i>	Configures HTTP endpoints on which to listen for DNS-over-HTTPS (DoH) queries.
<i>http-listener-clients</i>	Limits the number of active concurrent connections on a per-listener basis.
<i>http-port</i>	Specifies the TCP port number the server uses to receive and send unencrypted DNS traffic via HTTP.
<i>http-streams-per-connection</i>	Limits the number of active concurrent HTTP/2 streams on a per-connection basis.
<i>https-port</i>	Specifies the TCP port number the server uses to receive and send DNS-over-HTTPS protocol traffic.
<i>inet</i>	Specifies a TCP socket as a control channel.
<i>interface-interval</i>	Sets the interval at which the server scans the network interface list.
<i>ipv4-prefix-length</i>	Specifies the prefix lengths of IPv4 address blocks.
<i>ipv4only-contact</i>	Specifies the contact for the IPV4ONLY.ARPA zone created by <i>dns64</i> .
<i>ipv4only-server</i>	Specifies the name of the server for the IPV4ONLY.ARPA zone created by <i>dns64</i> .
<i>ipv6-prefix-length</i>	Specifies the prefix lengths of IPv6 address blocks.
<i>keep-response-order</i>	Defines an <i>address_match_list</i> of addresses which do not accept reordered answers within a single TCP stream.
<i>key-file</i>	Specifies the path to a file containing the private TLS key for a connection.
<i>keys</i>	Specifies one or more <i>server_key</i> s to be used with a remote server.
<i>lame-ttl</i>	Sets the resolver's lame cache.
<i>listen-on</i>	Specifies the IPv4 addresses on which a server listens for DNS queries.
<i>listen-on-v6</i>	Specifies the IPv6 addresses on which a server listens for DNS queries.
<i>listener-clients</i>	Specifies a per-listener quota for active connections.

continues on next page

Table 5 – continued from previous page

Statement	Description
<i>lmdb-mapsize</i>	Sets a maximum size for the memory map of the new-zone database in LMDB database format.
<i>lock-file</i>	Sets the pathname of the file on which <i>named</i> attempts to acquire a file lock when starting for the first time.
<i>masterfile-format</i>	Specifies the file format of zone files.
<i>masterfile-style</i>	Specifies the format of zone files during a dump, when the <i>masterfile-format</i> is text.
<i>match-mapped-addresses</i>	Allows IPv4-mapped IPv6 addresses to match address-match list entries for corresponding IPv4 addresses.
<i>max-cache-size</i>	Sets the maximum amount of memory to use for an individual cache database and its associated metadata.
<i>max-cache-ttl</i>	Specifies the maximum time (in seconds) that the server caches ordinary (positive) answers.
<i>max-clients-per-query</i>	Sets the maximum number of simultaneous recursive clients accepted by the server for any given query before the server drops additional clients.
<i>max-ncache-ttl</i>	Specifies the maximum retention time (in seconds) for storage of negative answers in the server's cache.
<i>max-query-count</i>	Sets the maximum number of iterative queries while servicing a recursive query.
<i>max-query-restarts</i>	Sets the maximum number of chained CNAMEs to follow
<i>max-records</i>	Sets the maximum number of records permitted in a zone.
<i>max-records-per-type</i>	Sets the maximum number of records that can be stored in an RRset.
<i>max-recursion-depth</i>	Sets the maximum number of levels of recursion permitted at any one time while servicing a recursive query.
<i>max-recursion-queries</i>	Sets the maximum number of iterative queries while servicing a recursive query.
<i>max-stale-ttl</i>	Specifies the maximum time that the server retains records past their normal expiry, to return them as stale records.
<i>max-table-size</i>	Sets the maximum size of the table used to track requests and rate-limit responses.

continues on next page

Table 5 – continued from previous page

Statement	Description
<i>max-types-per-name</i>	Sets the maximum number of RR types that can be stored for an owner name.
<i>memstatistics</i>	Controls whether memory statistics are written to the file specified by <i>memstatistics-file</i> at exit.
<i>min-cache-ttl</i>	Specifies the minimum time (in seconds) that the server caches ordinary (positive) answers.
<i>min-ncache-ttl</i>	Specifies the minimum retention time (in seconds) for storage of negative answers in the server's cache.
<i>no-case-compress</i>	Specifies a list of addresses that require case-insensitive compression in responses.
<i>options</i>	Defines global options to be used by BIND 9.
<i>padding</i>	Adds EDNS Padding options to outgoing messages to increase the packet size.
<i>pid-file</i>	Specifies the pathname of the file where the server writes its process ID.
<i>plugin</i>	Configures plugins in <i>named.conf</i> .
<i>port</i>	Specifies the UDP/TCP port number the server uses to receive and send DNS protocol traffic.
<i>prefer-server-ciphers</i>	Specifies that server ciphers should be preferred over client ones.
<i>querylog</i>	Specifies whether query logging should be active when <i>named</i> first starts.
<i>recursing-file</i>	Specifies the pathname of the file where the server dumps queries that are currently recursing via <i>rndc recursing</i> .
<i>response-policy</i>	Specifies response policy zones for the view or among global options.
<i>reuseport</i>	Enables kernel load-balancing of sockets.
<i>root-key-sentinel</i>	Controls whether BIND 9 responds to root key sentinel probes.
<i>server</i>	Defines characteristics to be associated with a remote name server.

continues on next page

Table 5 – continued from previous page

Statement	Description
<i>server-id</i>	Specifies the ID of the server to return in response to a <code>ID . SERVER</code> query.
<i>servfail-ttl</i>	Sets the length of time (in seconds) that a <code>SERVFAIL</code> response is cached.
<i>stale-answer-client-timeout</i>	Defines the amount of time (in milliseconds) that <i>named</i> waits before attempting to answer a query with a stale <code>RRset</code> from cache.
<i>stale-answer-enable</i>	Enables the returning of "stale" cached answers when the name servers for a zone are not answering.
<i>stale-cache-enable</i>	Enables the retention of "stale" cached answers.
<i>stale-refresh-time</i>	Sets the time window for the return of "stale" cached answers before the next attempt to contact, if the name servers for a given zone are not responding.
<i>statistics-file</i>	Specifies the pathname of the file where the server appends statistics, when using <code>rndc stats</code> .
<i>streams-per-connection</i>	Specifies the maximum number of concurrent <code>HTTP/2</code> streams over an <code>HTTP/2</code> connection.
<i>tcp-clients</i>	Specifies the maximum number of simultaneous client <code>TCP</code> connections accepted by the server.
<i>tcp-initial-timeout</i>	Sets the amount of time (in milliseconds) that the server waits on a new <code>TCP</code> connection for the first message from the client.
<i>tcp-keepalive</i>	Adds <code>EDNS TCP keepalive</code> to messages sent over <code>TCP</code> .
<i>tcp-listen-queue</i>	Sets the listen-queue depth.
<i>tcp-only</i>	Sets the transport protocol to <code>TCP</code> .
<i>tcp-receive-buffer</i>	Sets the operating system's receive buffer size for <code>TCP</code> sockets.
<i>tcp-send-buffer</i>	Sets the operating system's send buffer size for <code>TCP</code> sockets.
<i>tls-port</i>	Specifies the <code>TCP</code> port number the server uses to receive and send <code>DNS-over-TLS</code> protocol traffic.
<i>transfers</i>	Limits the number of concurrent inbound zone transfers from a server.

continues on next page

Table 5 – continued from previous page

Statement	Description
<i>udp-recv-buffer</i>	Sets the operating system's receive buffer size for UDP sockets.
<i>udp-send-buffer</i>	Sets the operating system's send buffer size for UDP sockets.
<i>unix</i>	Specifies a Unix domain socket as a control channel.
<i>update-quota</i>	Specifies the maximum number of concurrent DNS UPDATE messages that can be processed by the server.
<i>v6-bias</i>	Indicates the number of milliseconds of preference to give to IPv6 name servers.
<i>version</i>	Specifies the version number of the server to return in response to a <code>version.bind</code> query.
<i>zero-no-soa-ttl</i>	Specifies whether to set the time to live (TTL) of the SOA record to zero, when returning authoritative negative responses to SOA queries.
<i>zero-no-soa-ttl-cache</i>	Sets the time to live (TTL) to zero when caching a negative response to an SOA query.

### 8.4.6 Transfer Tag Statements

Statement	Description
<i>allow-notify</i>	Defines an <i>address_match_list</i> that is allowed to send NOTIFY messages for the zone, in addition to addresses defined in the <i>primaries</i> option for the zone.
<i>allow-transfer</i>	Defines an <i>address_match_list</i> of hosts that are allowed to transfer the zone information from this server.
<i>allow-update</i>	Defines an <i>address_match_list</i> of hosts that are allowed to submit dynamic updates for primary zones.
<i>allow-update-forwarding</i>	Defines an <i>address_match_list</i> of hosts that are allowed to submit dynamic updates to a secondary server for transmission to a primary.
<i>also-notify</i>	Defines one or more hosts that are sent NOTIFY messages when zone changes occur.
<i>ixfr-from-differences</i>	Controls how IXFR transfers are calculated.

continues on next page

Table 6 – continued from previous page

Statement	Description
<i>max-ixfr-ratio</i>	Sets the maximum size for IXFR responses to zone transfer requests.
<i>max-journal-size</i>	Controls the size of journal files.
<i>max-refresh-time</i>	Limits the zone refresh interval to no less often than the specified value, in seconds.
<i>max-retry-time</i>	Limits the zone refresh retry interval to no less often than the specified value, in seconds.
<i>max-transfer-idle-in</i>	Specifies the number of minutes after which inbound zone transfers making no progress are terminated.
<i>max-transfer-idle-out</i>	Specifies the number of minutes after which outbound zone transfers making no progress are terminated.
<i>max-transfer-time-in</i>	Specifies the number of minutes after which inbound zone transfers are terminated.
<i>max-transfer-time-out</i>	Specifies the number of minutes after which outbound zone transfers are terminated.
<i>min-refresh-time</i>	Limits the zone refresh interval to no more often than the specified value, in seconds.
<i>min-retry-time</i>	Limits the zone refresh retry interval to no more often than the specified value, in seconds.
<i>multi-master</i>	Controls whether serial number mismatch errors are logged.
<i>notify</i>	Controls whether NOTIFY messages are sent on zone changes.
<i>notify-delay</i>	Sets the delay (in seconds) between sending sets of NOTIFY messages for a zone.
<i>notify-rate</i>	Specifies the rate at which NOTIFY requests are sent during normal zone maintenance operations.
<i>notify-source</i>	Defines the IPv4 address (and optional port) to be used for outgoing NOTIFY messages.
<i>notify-source-v6</i>	Defines the IPv6 address (and optional port) to be used for outgoing NOTIFY messages.
<i>notify-to-soa</i>	Controls whether the name servers in the NS RRset are checked against the SOA MNAME.

continues on next page

Table 6 – continued from previous page

Statement	Description
<i>provide-ixfr</i>	Controls whether a primary responds to an incremental zone request (IXFR) or only responds with a full zone transfer (AXFR).
<i>request-expire</i>	Specifies whether the local server requests the EDNS EXPIRE value, when acting as a secondary.
<i>request-ixfr</i>	Controls whether a secondary requests an incremental zone transfer (IXFR) or a full zone transfer (AXFR).
<i>serial-query-rate</i>	Defines an upper limit on the number of queries per second issued by the server, when querying the SOA RRs used for zone transfers.
<i>startup-notify-rate</i>	Specifies the rate at which NOTIFY requests are sent when the name server is first starting, or when new zones have been added.
<i>transfer-format</i>	Controls whether multiple records can be packed into a message during zone transfers.
<i>transfer-message-size</i>	Limits the uncompressed size of DNS messages used in zone transfers over TCP.
<i>transfer-source</i>	Defines which local IPv4 address(es) are bound to TCP connections used to fetch zones transferred inbound by the server.
<i>transfer-source-v6</i>	Defines which local IPv6 address(es) are bound to TCP connections used to fetch zones transferred inbound by the server.
<i>transfers-in</i>	Limits the number of concurrent inbound zone transfers.
<i>transfers-out</i>	Limits the number of concurrent outbound zone transfers.
<i>transfers-per-ns</i>	Limits the number of concurrent inbound zone transfers from a remote server.
<i>try-tcp-refresh</i>	Specifies that BIND 9 should attempt to refresh a zone using TCP if UDP queries fail.
<i>update-policy</i>	Sets fine-grained rules to allow or deny dynamic updates (DDNS), based on requester identity, updated content, etc.

### 8.4.7 View Tag Statements

Statement	Description
<i>attach-cache</i>	Allows multiple views to share a single cache database.
<i>in-view</i>	Specifies the view in which a given zone is defined.
<i>match-clients</i>	Specifies a view of DNS namespace for a given subset of client IP addresses.
<i>match-destinations</i>	Specifies a view of DNS namespace for a given subset of destination IP addresses.
<i>match-recursive-only</i>	Specifies that only recursive requests can match this view of the DNS namespace.
<i>view</i>	Allows a name server to answer a DNS query differently depending on who is asking.

### 8.4.8 Zone Tag Statements

Statement	Description
<i>allow-new-zones</i>	Controls the ability to add zones at runtime via <i>rndc addzone</i> .
<i>catalog-zones</i>	Configures catalog zones in <i>named.conf</i> .
<i>check-integrity</i>	Performs post-load zone integrity checks on primary zones.
<i>check-mx</i>	Checks whether an MX record appears to refer to an IP address.
<i>check-mx-cname</i>	Sets the response to MX records that refer to CNAMEs.
<i>check-sibling</i>	Specifies whether to check for sibling glue when performing integrity checks.
<i>check-spf</i>	Specifies whether to check for a TXT Sender Policy Framework record, if an SPF record is present.
<i>check-srv-cname</i>	Sets the response to SRV records that refer to CNAMEs.
<i>check-wildcard</i>	Checks for non-terminal wildcards.
<i>database</i>	Specifies the type of database to be used to store zone data.
<i>disable-ds-digests</i>	Disables DS digest types from a specified zone.
<i>disable-empty-zone</i>	Disables individual empty zones.

continues on next page

Table 7 – continued from previous page

Statement	Description
<i>dlz</i>	Configures a Dynamically Loadable Zone (DLZ) database in <i>named.conf</i> .
<i>dyndb</i>	Configures a DynDB database in <i>named.conf</i> .
<i>empty-contact</i>	Specifies the contact name in the returned SOA record for empty zones.
<i>empty-server</i>	Specifies the server name in the returned SOA record for empty zones.
<i>empty-zones-enable</i>	Enables or disables all empty zones.
<i>file</i>	Specifies the zone's filename.
<i>flush-zones-on-shutdown</i>	Controls whether pending zone writes are flushed when the name server exits.
<i>in-view</i>	Specifies the view in which a given zone is defined.
<i>inline-signing</i>	Specifies whether BIND 9 maintains a separate signed version of a zone.
<i>journal</i>	Allows the default journal's filename to be overridden.
<i>masterfile-format</i>	Specifies the file format of zone files.
<i>max-records</i>	Sets the maximum number of records permitted in a zone.
<i>max-zone-ttl</i>	Specifies a maximum permissible time-to-live (TTL) value, in seconds.
<i>new-zones-directory</i>	Specifies the directory where configuration parameters are stored for zones added by <i>rndc addzone</i> .
<i>notify-delay</i>	Sets the delay (in seconds) between sending sets of NOTIFY messages for a zone.
<i>notify-rate</i>	Specifies the rate at which NOTIFY requests are sent during normal zone maintenance operations.
<i>parent-propagation-delay</i>	Sets the propagation delay from the time the parent zone is updated to when the new version is served by all of the parent zone's name servers.
<i>parental-agents</i>	Defines a list of delegation agents to be used by primary and secondary zones.
<i>primaries</i>	Defines one or more primary servers for a zone.

continues on next page

Table 7 – continued from previous page

Statement	Description
<i>response-policy</i>	Specifies response policy zones for the view or among global options.
<i>serial-update-method</i>	Specifies the update method to be used for the zone serial number in the SOA record.
<i>server-addresses</i>	Specifies a list of IP addresses to which queries should be sent in recursive resolution for a static-stub zone.
<i>server-names</i>	Specifies a list of domain names of name servers that act as authoritative servers of a static-stub zone.
<i>startup-notify-rate</i>	Specifies the rate at which NOTIFY requests are sent when the name server is first starting, or when new zones have been added.
<i>type</i>	Specifies the kind of zone in a given configuration.
<i>type forward</i>	Contains forwarding statements that apply to queries within a given domain.
<i>type hint</i>	Contains the initial set of root name servers to be used at BIND 9 startup.
<i>type mirror</i>	Contains a DNSSEC-validated duplicate of the main data for a zone.
<i>type primary</i>	Contains the main copy of the data for a zone.
<i>type redirect</i>	Contains information to answer queries when normal resolution would return NXDOMAIN.
<i>type secondary</i>	Contains a duplicate of the data for a zone that has been transferred from a primary server.
<i>type static-stub</i>	Contains statically configured NS records for a zone.
<i>type stub</i>	Contains a duplicate of the NS records of a zone.
<i>update-check-ksk</i>	Specifies whether to check the KSK bit to determine how a key should be used, when generating RRSIGs for a secure zone.
<i>zero-no-soa-ttl</i>	Specifies whether to set the time to live (TTL) of the SOA record to zero, when returning authoritative negative responses to SOA queries.
<i>zero-no-soa-ttl-cache</i>	Sets the time to live (TTL) to zero when caching a negative response to an SOA query.

continues on next page

Table 7 – continued from previous page

Statement	Description
<i>zone</i>	Specifies the zone in a BIND 9 configuration.
<i>zone-propagation-delay</i>	Sets the propagation delay from the time a zone is first updated to when the new version of the zone is served by all secondary servers.
<i>zone-statistics</i>	Controls the level of statistics gathered for all zones.



### 8.4.9 Deprecated Tag Statements

Statement	Description
<i>alt-transfer-source</i>	Defines alternate local IPv4 address(es) to be used by the server for inbound zone transfers, if the address(es) defined by <i>transfer-source</i> fail and <i>use-alt-transfer-source</i> is enabled.
<i>alt-transfer-source-v6</i>	Defines alternate local IPv6 address(es) to be used by the server for inbound zone transfers.
<i>avoid-v4-udp-ports</i>	Specifies the range(s) of ports to be excluded from use as sources for UDP/IPv4 messages.
<i>avoid-v6-udp-ports</i>	Specifies the range(s) of ports to be excluded from use as sources for UDP/IPv6 messages.
<i>coresize</i>	Sets the maximum size of a core dump.
<i>datasize</i>	Sets the maximum amount of data memory that can be used by the server.
<i>delegation-only</i>	Indicates that a forward, hint, or stub zone is to be treated as a delegation-only type zone.
<i>dialup</i>	Concentrates zone maintenance so that all transfers take place once every <i>heartbeat-interval</i> , ideally during a single call.
<i>dnssec-must-be-secure</i>	Defines hierarchies that must or may not be secure (signed and validated).
<i>files</i>	Sets the maximum number of files the server may have open concurrently.
<i>glue-cache</i>	Deprecated.
<i>heartbeat-interval</i>	Sets the interval at which the server performs zone maintenance tasks for all zones marked as <i>dialup</i> .
<i>managed-keys</i>	Deprecated, use <i>trust-anchors</i> .
<i>reserved-sockets</i>	Deprecated.
<i>resolver-retry-interval</i>	Sets the base retry interval (in milliseconds).
<i>root-delegation-only</i>	Turns on enforcement of delegation-only in top-level domains (TLDs) and root zones with an optional exclude list.
<i>stacksize</i>	Sets the maximum amount of stack memory that can be used by the server.
<i>tkey-dhkey</i>	Sets the Diffie-Hellman key used by the server to generate shared keys.
<i>trusted-keys</i>	Deprecated, use <i>trust-anchors</i> .
<i>type-delegation-only</i>	Enforces the delegation-only status of infrastructure zones (COM, NET, ORG, etc.).
<i>use-alt-transfer-source</i>	Indicates whether <i>alt-transfer-source</i> and <i>alt-transfer-source-v6</i> can be used.
<i>use-v4-udp-ports</i>	Specifies a list of ports that are valid sources for UDP/IPv4 messages.
<i>use-v6-udp-ports</i>	Specifies a list of ports that are valid sources for UDP/IPv6 messages.

## 8.5 BIND 9 Statistics

BIND 9 maintains lots of statistics information and provides several interfaces for users to access those statistics. The available statistics include all statistics counters that are meaningful in BIND 9, and other information that is considered useful.

The statistics information is categorized into the following sections:

### Incoming Requests

The number of incoming DNS requests for each OPCODE.

### Incoming Queries

The number of incoming queries for each RR type.

### Outgoing Queries

The number of outgoing queries for each RR type sent from the internal resolver, maintained per view.

### Name Server Statistics

Statistics counters for incoming request processing.

### Zone Maintenance Statistics

Statistics counters regarding zone maintenance operations, such as zone transfers.

### Resolver Statistics

Statistics counters for name resolutions performed in the internal resolver, maintained per view.

### Cache DB RRsets

Statistics counters related to cache contents, maintained per view.

The "NXDOMAIN" counter is the number of names that have been cached as nonexistent. Counters named for RR types indicate the number of active RRsets for each type in the cache database.

If an RR type name is preceded by an exclamation point (!), it represents the number of records in the cache which indicate that the type does not exist for a particular name; this is also known as "NXRRSET". If an RR type name is preceded by a hash mark (#), it represents the number of RRsets for this type that are present in the cache but whose TTLs have expired; these RRsets may only be used if stale answers are enabled. If an RR type name is preceded by a tilde (~), it represents the number of RRsets for this type that are present in the cache database but are marked for garbage collection; these RRsets cannot be used.

### Socket I/O Statistics

Statistics counters for network-related events.

A subset of Name Server Statistics is collected and shown per zone for which the server has the authority, when *zone-statistics* is set to *full* (or *yes*), for backward compatibility. See the description of *zone-statistics* in *options* for further details.

These statistics counters are shown with their zone and view names. The view name is omitted when the server is not configured with explicit views.

There are currently two user interfaces to get access to the statistics. One is in plain-text format, dumped to the file specified by the *statistics-file* configuration option; the other is remotely accessible via a statistics channel when the *statistics-channels* statement is specified in the configuration file.

### 8.5.1 The Statistics File

The text format statistics dump begins with a line, like:

```
+++ Statistics Dump +++ (973798949)
```

The number in parentheses is a standard Unix-style timestamp, measured in seconds since January 1, 1970. Following that line is a set of statistics information, which is categorized as described above. Each section begins with a line, like:

```
++ Name Server Statistics ++
```

Each section consists of lines, each containing the statistics counter value followed by its textual description; see below for available counters. For brevity, counters that have a value of 0 are not shown in the statistics file.

The statistics dump ends with the line where the number is identical to the number in the beginning line; for example:

```
--- Statistics Dump --- (973798949)
```

## 8.5.2 Statistics Counters

The following lists summarize the statistics counters that BIND 9 provides. For each counter, the abbreviated symbol name is given; these symbols are shown in the statistics information accessed via an HTTP statistics channel. The description of the counter is also shown in the statistics file but, in this document, may be slightly modified for better readability.

### Name Server Statistics Counters

**Requestv4**

This indicates the number of IPv4 requests received. Note: this also counts non-query requests.

**Requestv6**

This indicates the number of IPv6 requests received. Note: this also counts non-query requests.

**ReqEdns0**

This indicates the number of requests received with EDNS(0).

**ReqBadEDN SVer**

This indicates the number of requests received with an unsupported EDNS version.

**ReqTSIG**

This indicates the number of requests received with TSIG.

**ReqSIG0**

This indicates the number of requests received with SIG(0).

**ReqBadSIG**

This indicates the number of requests received with an invalid (TSIG or SIG(0)) signature.

**ReqTCP**

This indicates the number of TCP requests received.

**AuthQryRej**

This indicates the number of rejected authoritative (non-recursive) queries.

**RecQryRej**

This indicates the number of rejected recursive queries.

**XfrRej**

This indicates the number of rejected zone transfer requests.

**UpdateRej**

This indicates the number of rejected dynamic update requests.

**Response**

This indicates the number of responses sent.

**RespTruncated**

This indicates the number of truncated responses sent.

**RespEDNS0**

This indicates the number of responses sent with EDNS(0).

**RespTSIG**

This indicates the number of responses sent with TSIG.

**RespSIG0**

This indicates the number of responses sent with SIG(0).

**QrySuccess**

This indicates the number of queries that resulted in a successful answer, meaning queries which return a NO-ERROR response with at least one answer RR. This corresponds to the `success` counter of previous versions of BIND 9.

**QryAuthAns**

This indicates the number of queries that resulted in an authoritative answer.

**QryNoauthAns**

This indicates the number of queries that resulted in a non-authoritative answer.

**QryReferral**

This indicates the number of queries that resulted in a referral answer. This corresponds to the `referral` counter of previous versions of BIND 9.

**QryNxrrset**

This indicates the number of queries that resulted in NOERROR responses with no data. This corresponds to the `nxrrset` counter of previous versions of BIND 9.

**QrySERVFAIL**

This indicates the number of queries that resulted in SERVFAIL.

**QryFORMERR**

This indicates the number of queries that resulted in FORMERR.

**QryNXDOMAIN**

This indicates the number of queries that resulted in NXDOMAIN. This corresponds to the `nxdomain` counter of previous versions of BIND 9.

**QryRecursion**

This indicates the number of queries that caused the server to perform recursion in order to find the final answer. This corresponds to the `recursion` counter of previous versions of BIND 9.

**QryDuplicate**

This indicates the number of queries which the server attempted to recurse but for which it discovered an existing query with the same IP address, port, query ID, name, type, and class already being processed. This corresponds to the `duplicate` counter of previous versions of BIND 9.

**QryDropped**

This indicates the number of recursive queries dropped by the server as a result of configured limits. These limits include the settings of the `fetches-per-zone`, `fetches-per-server`, `clients-per-query`, and `max-clients-per-query` options, as well as the `rate-limit` option. This corresponds to the `dropped` counter of previous versions of BIND 9.

**QryFailure**

This indicates the number of query failures. This corresponds to the `failure` counter of previous versions of BIND 9. Note: this counter is provided mainly for backward compatibility with previous versions; normally, more fine-grained counters such as `AuthQryRej` and `RecQryRej` that would also fall into this counter are provided, so this counter is not of much interest in practice.

**QryNXRedir**

This indicates the number of queries that resulted in NXDOMAIN that were redirected.

**QryNXRedirRLookup**

This indicates the number of queries that resulted in NXDOMAIN that were redirected and resulted in a successful

remote lookup.

**XfrReqDone**

This indicates the number of requested and completed zone transfers.

**UpdateReqFwd**

This indicates the number of forwarded update requests.

**UpdateRespFwd**

This indicates the number of forwarded update responses.

**UpdateFwdFail**

This indicates the number of forwarded dynamic updates that failed.

**UpdateDone**

This indicates the number of completed dynamic updates.

**UpdateFail**

This indicates the number of failed dynamic updates.

**UpdateBadPrereq**

This indicates the number of dynamic updates rejected due to a prerequisite failure.

**UpdateQuota**

This indicates the number of times a dynamic update or update forwarding request was rejected because the number of pending requests exceeded *update-quota*.

**RateDropped**

This indicates the number of responses dropped due to rate limits.

**RateSlipped**

This indicates the number of responses truncated by rate limits.

**RPZRewrites**

This indicates the number of response policy zone rewrites.

**Zone Maintenance Statistics Counters****NotifyOutv4**

This indicates the number of IPv4 notifies sent.

**NotifyOutv6**

This indicates the number of IPv6 notifies sent.

**NotifyInv4**

This indicates the number of IPv4 notifies received.

**NotifyInv6**

This indicates the number of IPv6 notifies received.

**NotifyRej**

This indicates the number of incoming notifies rejected.

**SOAOutv4**

This indicates the number of IPv4 SOA queries sent.

**SOAOutv6**

This indicates the number of IPv6 SOA queries sent.

**AXFRReqv4**

This indicates the number of requested IPv4 AXFRs.

**AXFRReqv6**

This indicates the number of requested IPv6 AXFRs.

**IXFRReqv4**

This indicates the number of requested IPv4 IXFRs.

**IXFRReqv6**

This indicates the number of requested IPv6 IXFRs.

**XfrSuccess**

This indicates the number of successful zone transfer requests.

**XfrFail**

This indicates the number of failed zone transfer requests.

**Resolver Statistics Counters**

**Queryv4**

This indicates the number of IPv4 queries sent.

**Queryv6**

This indicates the number of IPv6 queries sent.

**Responsev4**

This indicates the number of IPv4 responses received.

**Responsev6**

This indicates the number of IPv6 responses received.

**NXDOMAIN**

This indicates the number of NXDOMAINs received.

**SERVFAIL**

This indicates the number of SERVFAILs received.

**FORMERR**

This indicates the number of FORMERRs received.

**OtherError**

This indicates the number of other errors received.

**EDNSOFail**

This indicates the number of EDNS(0) query failures.

**Mismatch**

This indicates the number of mismatched responses received, meaning the DNS ID, response's source address, and/or the response's source port does not match what was expected. (The port must be 53 or as defined by the *port* option.) This may be an indication of a cache poisoning attempt.

**Truncated**

This indicates the number of truncated responses received.

**Lame**

This indicates the number of lame delegations received.

**Retry**

This indicates the number of query retries performed.

**QueryAbort**

This indicates the number of queries aborted due to quota control.

**QuerySockFail**

This indicates the number of failures in opening query sockets. One common reason for such failures is due to a limitation on file descriptors.

**QueryCurUDP**

This indicates the number of UDP queries in progress.

**QueryCurTCP**

This indicates the number of TCP queries in progress.

**QueryTimeout**

This indicates the number of query timeouts.

**GlueFetchv4**

This indicates the number of IPv4 NS address fetches invoked.

**GlueFetchv6**

This indicates the number of IPv6 NS address fetches invoked.

**GlueFetchv4Fail**

This indicates the number of failed IPv4 NS address fetches.

**GlueFetchv6Fail**

This indicates the number of failed IPv6 NS address fetches.

**ValAttempt**

This indicates the number of attempted DNSSEC validations.

**ValOk**

This indicates the number of successful DNSSEC validations.

**ValNegOk**

This indicates the number of successful DNSSEC validations on negative information.

**ValFail**

This indicates the number of failed DNSSEC validations.

**QryRTTnn**

This provides a frequency table on query round-trip times (RTTs). Each *nn* specifies the corresponding frequency. In the sequence of *nn*<sub>1</sub>, *nn*<sub>2</sub>, ..., *nn*<sub>*m*</sub>, the value of *nn*<sub>*i*</sub> is the number of queries whose RTTs are between *nn*<sub>(*i*-1)</sub> (inclusive) and *nn*<sub>*i*</sub> (exclusive) milliseconds. For the sake of convenience, we define *nn*<sub>0</sub> to be 0. The last entry should be represented as *nn*<sub>*m*</sub>+, which means the number of queries whose RTTs are equal to or greater than *nn*<sub>*m*</sub> milliseconds.

**NumFetch**

This indicates the number of active fetches.

**BucketSize**

This indicates the number of the resolver's internal buckets (a static number).

**REFUSED**

This indicates the number of REFUSED responses received.

**ClientCookieOut**

This indicates the number of COOKIE messages sent to an authoritative server with only a client cookie.

**ServerCookieOut**

This indicates the number of COOKIE messages sent to an authoritative server with both a client and a cached server cookie.

**CookieIn**

This indicates the number of COOKIE replies received from an authoritative server.

**CookieClientOk**

This indicates the number of correctly formed COOKIE client responses received.

**BadEDNSVersion**

This indicates the number of bad EDNS version replies received.

**BadCookieRcode**

This indicates the number of BADCOOKIE response codes received from an authoritative server.

**ZoneQuota**

This indicates the number of queries spilled for exceeding the *fetches-per-zone* quota.

**ServerQuota**

This indicates the number of queries spilled for exceeding the *fetches-per-server* quota.

**ClientQuota**

This indicates the number of queries spilled for exceeding the *clients-per-query* quota.

**NextItem**

This indicates the number of times the server waited for the next item after receiving an invalid response.

**Priming**

This indicates the number of priming fetches performed by the resolver.

**Socket I/O Statistics Counters**

Socket I/O statistics counters are defined per socket type, which are UDP4 (UDP/IPv4), UDP6 (UDP/IPv6), TCP4 (TCP/IPv4), TCP6 (TCP/IPv6), Unix (Unix Domain), and FDwatch (sockets opened outside the socket module). In the following list, <TYPE> represents a socket type. Not all counters are available for all socket types; exceptions are noted in the descriptions.

**<TYPE>Open**

This indicates the number of sockets opened successfully. This counter does not apply to the FDwatch type.

**<TYPE>OpenFail**

This indicates the number of failures to open sockets. This counter does not apply to the FDwatch type.

**<TYPE>Close**

This indicates the number of closed sockets.

**<TYPE>BindFail**

This indicates the number of failures to bind sockets.

**<TYPE>ConnFail**

This indicates the number of failures to connect sockets.

**<TYPE>Conn**

This indicates the number of connections established successfully.

**<TYPE>AcceptFail**

This indicates the number of failures to accept incoming connection requests. This counter does not apply to the UDP and FDwatch types.

**<TYPE>Accept**

This indicates the number of incoming connections successfully accepted. This counter does not apply to the UDP and FDwatch types.

**<TYPE>SendErr**

This indicates the number of errors in socket send operations.

**<TYPE>RecvErr**

This indicates the number of errors in socket receive operations, including errors of send operations on a connected UDP socket, notified by an ICMP error message.

**TCP4Clients/TCP6Clients**

This indicates the number of IPv4/IPv6 clients currently connected over TCP.



## TROUBLESHOOTING

### 9.1 Common Problems

#### 9.1.1 It's Not Working; How Can I Figure Out What's Wrong?

The best solution to installation and configuration issues is to take preventive measures by setting up logging files beforehand. The log files provide hints and information that can be used to identify anything that went wrong and fix the problem.

#### 9.1.2 EDNS Compliance Issues

EDNS (Extended DNS) is a standard that was first specified in 1999. It is required for DNSSEC validation, DNS COOKIE options, and other features. There are broken and outdated DNS servers and firewalls still in use which misbehave when queried with EDNS; for example, they may drop EDNS queries rather than replying with FORMERR. BIND and other recursive name servers have traditionally employed workarounds in this situation, retrying queries in different ways and eventually falling back to plain DNS queries without EDNS.

Such workarounds cause unnecessary resolution delays, increase code complexity, and prevent deployment of new DNS features. In February 2019, all major DNS software vendors removed these workarounds; see <https://www.dnsflagday.net/2019/> for further details. This change was implemented in BIND as of release 9.14.0.

As a result, some domains may be non-resolvable without manual intervention. In these cases, resolution can be restored by adding `server` clauses for the offending servers, or by specifying `edns no` or `send-cookie no`, depending on the specific noncompliance.

To determine which `server` clause to use, run the following commands to send queries to the authoritative servers for the broken domain:

```
dig soa <zone> @<server> +dnssec
dig soa <zone> @<server> +dnssec +nookie
dig soa <zone> @<server> +noedns
```

If the first command fails but the second succeeds, the server most likely needs `send-cookie no`. If the first two fail but the third succeeds, then the server needs EDNS to be fully disabled with `edns no`.

Please contact the administrators of noncompliant domains and encourage them to upgrade their broken DNS servers.

#### 9.1.3 Inspecting Encrypted DNS Traffic

**Note**

This feature requires support from the cryptographic library that BIND 9 is built against. For OpenSSL, version 1.1.1 or newer is required (use `named -V` to check).

By definition, TLS-encrypted traffic (e.g. DNS over TLS, DNS over HTTPS) is opaque to packet sniffers, which makes debugging problems with encrypted DNS close to impossible. However, [Wireshark](#) offers a [solution](#) to this problem by being able to read key log files. In order to make `named` prepare such a file, set the `SSLKEYLOGFILE` environment variable to either:

- the string `config` (`SSLKEYLOGFILE=config`); this requires defining a *logging channel* which will handle messages belonging to the `sslkeylog` category,
- the path to the key file to write (`SSLKEYLOGFILE=/path/to/file`); this is equivalent to the following *logging* configuration:

```
channel default_sslkeylogfile {
    file "${SSLKEYLOGFILE}" versions 10 size 100m suffix timestamp;
};

category sslkeylog {
    default_sslkeylogfile;
};
```

**Note**

When using `SSLKEYLOGFILE=config`, augmenting the log channel output using options like `print-time` or `print-severity` is strongly discouraged as it will likely make the key log file unusable.

When the `SSLKEYLOGFILE` environment variable is set, each TLS connection established by `named` (both incoming and outgoing) causes about 1 kilobyte of data to be written to the key log file.

**Warning**

Due to the limitations of the current logging code in BIND 9, enabling TLS pre-master secret logging adversely affects `named` performance.

## 9.2 Incrementing and Changing the Serial Number

Zone serial numbers are just numbers — they are not date-related. However, many people set them to a number that represents a date, usually of the form `YYYYMMDDRR`. Occasionally they make a mistake and set the serial number to a date in the future, then try to correct it by setting it to the current date. This causes problems because serial numbers are used to indicate that a zone has been updated. If the serial number on the secondary server is lower than the serial number on the primary, the secondary server attempts to update its copy of the zone.

Setting the serial number to a lower number on the primary server than the one on the secondary server means that the secondary will not perform updates to its copy of the zone.

The solution to this is to add 2147483647 ( $2^{31}-1$ ) to the number, reload the zone and make sure all secondaries have updated to the new zone serial number, then reset it to the desired number and reload the zone again.

## 9.3 Where Can I Get Help?

The BIND-users mailing list, at <https://lists.isc.org/mailman/listinfo/bind-users>, is an excellent resource for peer user support. In addition, ISC maintains a Knowledgebase of helpful articles at <https://kb.isc.org>.

Internet Systems Consortium (ISC) offers annual support agreements for BIND 9, ISC DHCP, and Kea DHCP. All paid support contracts include advance security notifications; some levels include service level agreements (SLAs), premium software features, and increased priority on bug fixes and feature requests.

Please contact [info@isc.org](mailto:info@isc.org) or visit <https://www.isc.org/contact/> for more information.



## BUILDING BIND 9

To build on a Unix or Linux system, use:

```
$ autoreconf -fi ### (only if building from the git repository)
$ ./configure
$ make
```

Several environment variables affect compilation, and they can be set before running `configure`. The most significant ones are:

Variable	Description
CC	The C compiler to use. <code>configure</code> tries to figure out the right one for supported systems.
CFLAGS	The C compiler flags. Defaults to include <code>-g</code> and/or <code>-O2</code> as supported by the compiler. Please include <code>-g</code> if CFLAGS needs to be set.
LD-FLAGS	The linker flags. Defaults to an empty string.

Additional environment variables affecting the build are listed at the end of the `configure` help text, which can be obtained by running the command:

```
$ ./configure --help
```

If using Emacs, the `make tags` command may be helpful.

### 10.1 Required Libraries

To build BIND 9, the following packages must be installed:

- `libcrypto`, `libssl`
- `libuv`
- `perl`
- `pkg-config` / `pkgconfig` / `pkgconf`

BIND 9.18 requires `libuv` 1.0.0 or higher; using `libuv`  $\geq$  1.40.0 is recommended. Compiling or running with `libuv` 1.35.0 or 1.36.0 is not supported, as this could lead to an assertion failure in the UDP receive code. On older systems an updated `libuv` package needs to be installed from sources, such as EPEL, PPA, or other native sources. The other option is to build and install `libuv` from source.

OpenSSL 1.0.2e or newer is required. If the OpenSSL library is installed in a nonstandard location, specify the prefix using `--with-openssl=<PREFIX>` on the `configure` command line. To use a PKCS#11 hardware service module for cryptographic operations, `engine_pkcs11` from the OpenSC project must be compiled and used.

To build BIND from the git repository, the following tools must also be installed:

- `autoconf` (includes `autoreconf`)
- `automake`
- `libtool`

## 10.2 Optional Features

To see a full list of configuration options, run `configure --help`.

To improve performance, use of the `jemalloc` library (<http://jemalloc.net/>) is strongly recommended.

To support **DNS over HTTPS (DoH)**, the server must be linked with `libnghttp2` (<https://nghttp2.org/>). If the library is unavailable, `--disable-doh` can be used to disable DoH support.

To support the HTTP statistics channel, the server must be linked with at least one of the following libraries: `libxml2` (<https://gitlab.gnome.org/GNOME/libxml2/-/wikis/home>) or `json-c` (<https://github.com/json-c/json-c>). If these are installed at a nonstandard location, then:

- for `libxml2`, specify the prefix using `--with-libxml2=/prefix`,
- for `json-c`, adjust `PKG_CONFIG_PATH`.

To support compression on the HTTP statistics channel, the server must be linked against `zlib` (<https://zlib.net/>). If this is installed in a nonstandard location, specify the prefix using `--with-zlib=/prefix`.

To support storing configuration data for runtime-added zones in an LMDB database, the server must be linked with `liblmdb` (<https://github.com/LMDB/lmdb>). If this is installed in a nonstandard location, specify the prefix using `--with-lmdb=/prefix`.

To support MaxMind GeoIP2 location-based ACLs, the server must be linked with `libmaxminddb` (<https://maxmind.github.io/libmaxminddb/>). This is turned on by default if the library is found; if the library is installed in a nonstandard location, specify the prefix using `--with-maxminddb=/prefix`. GeoIP2 support can be switched off with `--disable-geoip`.

For DNSTAP packet logging, `libfstrm` (<https://github.com/farsightsec/fstrm>) and `libprotobuf-c` (<https://protobuf.dev>) must be installed, and BIND must be configured with `--enable-dnstap`.

To support internationalized domain names in `dig`, `libidn2` (<https://www.gnu.org/software/libidn/#libidn2>) must be installed. If the library is installed in a nonstandard location, specify the prefix using `--with-libidn2=/prefix` or adjust `PKG_CONFIG_PATH`.

For line editing in `nsupdate` and `nslookup`, either the `readline` (<https://tiswww.case.edu/php/chet/readline/rltop.html>) or the `libedit` library (<https://www.thrysooe.dk/editline/>) must be installed. If these are installed at a nonstandard location, adjust `PKG_CONFIG_PATH`. `readline` is used by default, and `libedit` can be explicitly requested using `--with-readline=libedit`.

Certain compiled-in constants and default settings can be decreased to values better suited to small machines, e.g. OpenWRT boxes, by specifying `--with-tuning=small` on the `configure` command line. This decreases memory usage by using smaller structures, but degrades performance.

On Linux, process capabilities are managed in user space using the `libcap` library (<https://git.kernel.org/pub/scm/libs/libcap/libcap.git/>), which can be installed on most Linux systems via the `libcap-dev` or `libcap-devel` package. Process capability support can also be disabled by configuring with `--disable-linux-caps`.

On some platforms it is necessary to explicitly request large file support to handle files bigger than 2GB. This can be done by using `--enable-largefile` on the `configure` command line.

Support for the “fixed” RRset-order option can be enabled or disabled by specifying `--enable-fixed-rrset` or `--disable-fixed-rrset` on the `configure` command line. By default, fixed RRset-order is disabled to reduce memory footprint.

The `--enable-querytrace` option causes `named` to log every step while processing every query. The `--enable-singletrace` option turns on the same verbose tracing, but allows an individual query to be separately traced by setting its query ID to 0. These options should only be enabled when debugging, because they have a significant negative impact on query performance.

`make install` installs `named` and the various BIND 9 libraries. By default, installation is into `/usr/local`, but this can be changed with the `--prefix` option when running `configure`.

The option `--sysconfdir` can be specified to set the directory where configuration files such as `named.conf` go by default; `--localstatedir` can be used to set the default parent directory of `run/named.pid`. `--sysconfdir` defaults to `$prefix/etc` and `--localstatedir` defaults to `$prefix/var`.

## 10.3 macOS

Building on macOS assumes that the “Command Tools for Xcode” are installed. These can be downloaded from <https://developer.apple.com/xcode/resources/> or, if Xcode is already installed, simply run `xcode-select --install`. (Note that an Apple ID may be required to access the download page.)



## 11.1 Preface

### 11.1.1 Organization

This document provides introductory information on how DNSSEC works, how to configure BIND 9 to support some common DNSSEC features, and some basic troubleshooting tips. The chapters are organized as follows:

*Introduction* covers the intended audience for this document, assumed background knowledge, and a basic introduction to the topic of DNSSEC.

*Getting Started* covers various requirements before implementing DNSSEC, such as software versions, hardware capacity, network requirements, and security changes.

*Validation* walks through setting up a validating resolver, and gives both more information on the validation process and some examples of tools to verify that the resolver is properly validating answers.

*Signing* explains how to set up a basic signed authoritative zone, details the relationship between a child and a parent zone, and discusses ongoing maintenance tasks.

*Basic DNSSEC Troubleshooting* provides some tips on how to analyze and diagnose DNSSEC-related problems.

*Advanced Discussions* covers several topics, including key generation, key storage, key management, NSEC and NSEC3, and some disadvantages of DNSSEC.

*Recipes* provides several working examples of common DNSSEC solutions, with step-by-step details.

*Commonly Asked Questions* lists some commonly asked questions and answers about DNSSEC.

### 11.1.2 Acknowledgements

This document was originally authored by Josh Kuo of [DeepDive Networking](#). He can be reached at [josh.kuo@gmail.com](mailto:josh.kuo@gmail.com).

Thanks to the following individuals (in no particular order) who have helped in completing this document: Jeremy C. Reed, Heidi Schempf, Stephen Morris, Jeff Osborn, Vicky Risk, Jim Martin, Evan Hunt, Mark Andrews, Michael McNally, Kelli Blucher, Chuck Aurora, Francis Dupont, Rob Nagy, Ray Bellis, Matthijs Mekking, and Suzanne Goldlust.

Special thanks goes to Cricket Liu and Matt Larson for their selflessness in knowledge sharing.

Thanks to all the reviewers and contributors, including John Allen, Jim Young, Tony Finch, Timothe Litt, and Dr. Jeffrey A. Spain.

The sections on key rollover and key timing metadata borrowed heavily from the Internet Engineering Task Force draft titled "DNSSEC Key Timing Considerations" by S. Morris, J. Ihren, J. Dickinson, and W. Mekking, subsequently published as [RFC 7583](#).

Icons made by [Freepik](#) and [SimpleIcon](#) from [Flaticon](#), licensed under [Creative Commons BY 3.0](#).

## 11.2 Introduction

### 11.2.1 Who Should Read this Guide?

This guide is intended as an introduction to DNSSEC for the DNS administrator who is already comfortable working with the existing BIND and DNS infrastructure. He or she might be curious about DNSSEC, but may not have had the time to investigate DNSSEC, to learn whether DNSSEC should be a part of his or her environment, and understand what it means to deploy it in the field.

This guide provides basic information on how to configure DNSSEC using BIND 9.16.9 or later. Most of the information and examples in this guide also apply to versions of BIND later than 9.9.0, but some of the key features described here were only introduced in version 9.16.9. Readers are assumed to have basic working knowledge of the Domain Name System (DNS) and related network infrastructure, such as concepts of TCP/IP. In-depth knowledge of DNS and TCP/IP is not required. The guide assumes no prior knowledge of DNSSEC or related technology such as public key cryptography.

### 11.2.2 Who May Not Want to Read this Guide?

If you are already operating a DNSSEC-signed zone, you may not learn much from the first half of this document, and you may want to start with *Advanced Discussions*. If you want to learn about details of the protocol extension, such as data fields and flags, or the new record types, this document can help you get started but it does not include all the technical details.

If you are experienced in DNSSEC, you may find some of the concepts in this document to be overly simplified for your taste, and some details are intentionally omitted at times for ease of illustration.

If you administer a large or complex BIND environment, this guide may not provide enough information for you, as it is intended to provide only basic, generic working examples.

If you are a top-level domain (TLD) operator, or administer zones under signed TLDs, this guide can help you get started, but it does not provide enough details to serve all of your needs.

If your DNS environment uses DNS products other than (or in addition to) BIND, this document may provide some background or overlapping information, but you should check each product's vendor documentation for specifics.

Finally, deploying DNSSEC on internal or private networks is not covered in this document, with the exception of a brief discussion in *DNSSEC on Private Networks*.

### 11.2.3 What is DNSSEC?

The Domain Name System (DNS) was designed in a day and age when the Internet was a friendly and trusting place. The protocol itself provides little protection against malicious or forged answers. DNS Security Extensions (DNSSEC) addresses this need, by adding digital signatures into DNS data so that each DNS response can be verified for integrity (the answer did not change during transit) and authenticity (the data came from the true source, not an impostor). In the ideal world, when DNSSEC is fully deployed, every single DNS answer can be validated and trusted.

DNSSEC does not provide a secure tunnel; it does not encrypt or hide DNS data. It operates independently of an existing Public Key Infrastructure (PKI). It does not need SSL certificates or shared secrets. It was designed with backwards compatibility in mind, and can be deployed without impacting "old" unsecured domain names.

DNSSEC is deployed on the three major components of the DNS infrastructure:

- *Recursive Servers*: People use recursive servers to lookup external domain names such as `www.example.com`. Operators of recursive servers need to enable DNSSEC validation. With validation enabled, recursive servers carry out additional tasks on each DNS response they receive to ensure its authenticity.
- *Authoritative Servers*: People who publish DNS data on their name servers need to sign that data. This entails creating additional resource records, and publishing them to parent domains where necessary. With DNSSEC enabled, authoritative servers respond to queries with additional DNS data, such as digital signatures and keys, in addition to the standard answers.

- *Applications*: This component lives on every client machine, from web servers to smart phones. This includes resolver libraries on different operating systems, and applications such as web browsers.

In this guide, we focus on the first two components, Recursive Servers and Authoritative Servers, and only lightly touch on the third component. We look at how DNSSEC works, how to configure a validating resolver, how to sign DNS zone data, and other operational tasks and considerations.

## 11.2.4 What Does DNSSEC Add to DNS?

### Note

Public Key Cryptography works on the concept of a pair of keys: one made available to the world publicly, and one kept in secrecy privately. Not surprisingly, they are known as a public key and a private key. If you are not familiar with the concept, think of it as a cleverly designed lock, where one key locks and one key unlocks. In DNSSEC, we give out the unlocking public key to the rest of the world, while keeping the locking key private. To learn how this is used to secure DNS messages, see *How Are Answers Verified?*.

DNSSEC introduces eight new resource record types:

- RRSIG (digital resource record signature)
- DNSKEY (public key)
- DS (parent-child)
- NSEC (proof of nonexistence)
- NSEC3 (proof of nonexistence)
- NSEC3PARAM (proof of nonexistence)
- CDS (child-parent signaling)
- CDNSKEY (child-parent signaling)

This guide does not go deep into the anatomy of each resource record type; the details are left for the reader to research and explore. Below is a short introduction on each of the new record types:

- *RRSIG*: With DNSSEC enabled, just about every DNS answer (A, PTR, MX, SOA, DNSKEY, etc.) comes with at least one resource record signature, or RRSIG. These signatures are used by recursive name servers, also known as validating resolvers, to verify the answers received. To learn how digital signatures are generated and used, see *How Are Answers Verified?*.
- *DNSKEY*: DNSSEC relies on public-key cryptography for data authenticity and integrity. There are several keys used in DNSSEC, some private, some public. The public keys are published to the world as part of the zone data, and they are stored in the DNSKEY record type.

In general, keys in DNSSEC are used for one or both of the following roles: as a Zone Signing Key (ZSK), used to protect all zone data; or as a Key Signing Key (KSK), used to protect the zone's keys. A key that is used for both roles is referred to as a Combined Signing Key (CSK). We talk about keys in more detail in *DNSSEC Keys*.

- *DS*: One of the critical components of DNSSEC is that the parent zone can "vouch" for its child zone. The DS record is verifiable information (generated from one of the child's public keys) that a parent zone publishes about its child as part of the chain of trust. To learn more about the Chain of Trust, see *Chain of Trust*.
- *NSEC, NSEC3, NSEC3PARAM*: These resource records all deal with a very interesting problem: proving that something does not exist. We look at these record types in more detail in *Proof of Non-Existence (NSEC and NSEC3)*.

- *CDS, CDNSKEY*: The CDS and CDNSKEY resource records apply to operational matters and are a way to signal to the parent zone that the DS records it holds for the child zone should be updated. This is covered in more detail in *The CDS and CDNSKEY Resource Records*.

### 11.2.5 How Does DNSSEC Change DNS Lookup?

Traditional (insecure) DNS lookup is simple: a recursive name server receives a query from a client to lookup a name like `www.isc.org`. The recursive name server tracks down the authoritative name server(s) responsible, sends the query to one of the authoritative name servers, and waits for it to respond with the answer.

With DNSSEC validation enabled, a validating recursive name server (a.k.a. a *validating resolver*) asks for additional resource records in its query, hoping the remote authoritative name servers respond with more than just the answer to the query, but some proof to go along with the answer as well. If DNSSEC responses are received, the validating resolver performs cryptographic computation to verify the authenticity (the origin of the data) and integrity (that the data was not altered during transit) of the answers, and even asks the parent zone as part of the verification. It repeats this process of get-key, validate, ask-parent, and its parent, and its parent, all the way until the validating resolver reaches a key that it trusts. In the ideal, fully deployed world of DNSSEC, all validating resolvers only need to trust one key: the root key.

### 11.2.6 The 12-Step DNSSEC Validation Process (Simplified)

The following example shows the 12 steps of the DNSSEC validating process at a very high level, looking up the name `www.isc.org`:

1. Upon receiving a DNS query from a client to resolve `www.isc.org`, the validating resolver follows standard DNS protocol to track down the name server for `isc.org`, and sends it a DNS query to ask for the A record of `www.isc.org`. But since this is a DNSSEC-enabled resolver, the outgoing query has a bit set indicating it wants DNSSEC answers, hoping the name server that receives it is DNSSEC-enabled and can honor this secure request.
2. The `isc.org` name server is DNSSEC-enabled, so it responds with both the answer (in this case, an A record) and a digital signature for verification purposes.
3. The validating resolver requires cryptographic keys to be able to verify the digital signature, so it asks the `isc.org` name server for those keys.
4. The `isc.org` name server responds with the cryptographic keys (and digital signatures of the keys) used to generate the digital signature that was sent in #2. At this point, the validating resolver can use this information to verify the answers received in #2.

Let's take a quick break here and look at what we've got so far... how can our server trust this answer? If a clever attacker had taken over the `isc.org` name server(s), of course she would send matching keys and signatures. We need to ask someone else to have confidence that we are really talking to the real `isc.org` name server. This is a critical part of DNSSEC: at some point, the DNS administrators at `isc.org` uploaded some cryptographic information to its parent, `.org`, maybe through a secure web form, maybe through an email exchange, or perhaps in person. In any event, at some point some verifiable information about the child (`isc.org`) was sent to the parent (`.org`) for safekeeping.

5. The validating resolver asks the parent (`.org`) for the verifiable information it keeps on its child, `isc.org`.
6. Verifiable information is sent from the `.org` server. At this point, the validating resolver compares this to the answer it received in #4; if the two of them match, it proves the authenticity of `isc.org`.

Let's examine this process. You might be thinking to yourself, what if the clever attacker that took over `isc.org` also compromised the `.org` servers? Of course all this information would match! That's why we turn our attention now to the `.org` server, interrogate it for its cryptographic keys, and move one level up to `.org`'s parent, root.

7. The validating resolver asks the `.org` authoritative name server for its cryptographic keys, to verify the answers received in #6.
8. The `.org` name server responds with the answer (in this case, keys and signatures). At this point, the validating resolver can verify the answers received in #6.

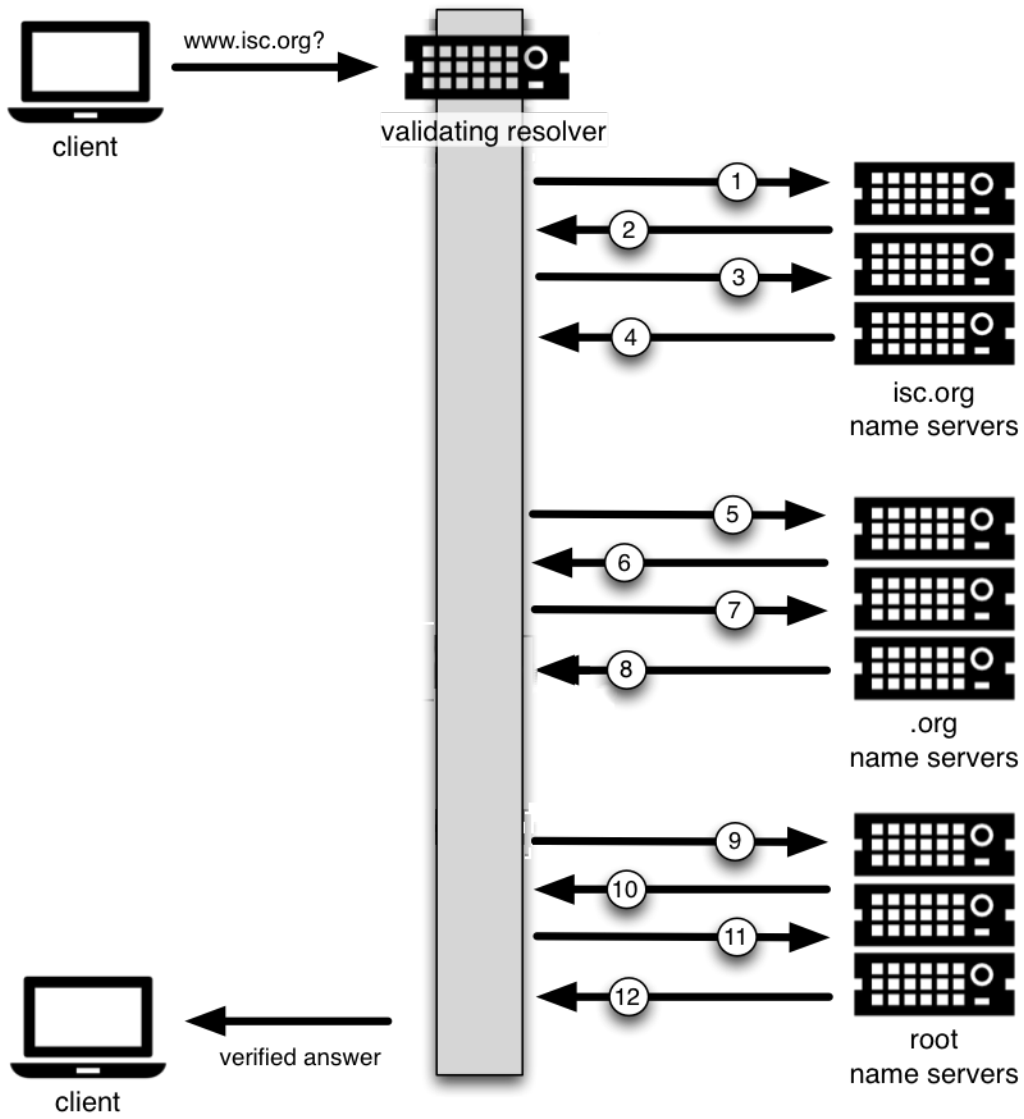

9. The validating resolver asks root (.org's parent) for the verifiable information it keeps on its child, .org.
10. The root name server sends back the verifiable information it keeps on .org. The validating resolver uses this information to verify the answers received in #8.

So at this point, both `isc.org` and `.org` check out. But what about root? What if this attacker is really clever and somehow tricked us into thinking she's the root name server? Of course she would send us all matching information! So we repeat the interrogation process and ask for the keys from the root name server.

11. The validating resolver asks the root name server for its cryptographic keys to verify the answer(s) received in #10.
12. The root name server sends its keys; at this point, the validating resolver can verify the answer(s) received in #10.

### 11.2.7 Chain of Trust

But what about the root server itself? Who do we go to verify root's keys? There's no parent zone for root. In security, you have to trust someone, and in the perfectly protected world of DNSSEC (we talk later about the current imperfect state and ways to work around it), each validating resolver would only have to trust one entity, that is, the root name server. The validating resolver already has the root key on file (we discuss later how we got the root key file). So after the answer in #12 is received, the validating resolver compares it to the key it already has on file. Providing one of the keys in the answer matches the one on file, we can trust the answer from root. Thus we can trust `.org`, and thus we can trust `isc.org`. This is known as the "chain of trust" in DNSSEC.

We revisit this 12-step process again later in *How Does DNSSEC Change DNS Lookup (Revisited)?* with more technical details.

### 11.2.8 Why is DNSSEC Important? (Why Should I Care?)

You might be thinking to yourself: all this DNSSEC stuff sounds wonderful, but why should I care? Below are some reasons why you may want to consider deploying DNSSEC:

1. *Being a good netizen*: By enabling DNSSEC validation (as described in *Validation*) on your DNS servers, you're protecting your users and yourself a little more by checking answers returned to you; by signing your zones (as described in *Signing*), you are making it possible for other people to verify your zone data. As more people adopt DNSSEC, the Internet as a whole becomes more secure for everyone.
2. *Compliance*: You may not even get a say in implementing DNSSEC, if your organization is subject to compliance standards that mandate it. For example, the US government set a deadline in 2008 to have all `.gov` subdomains signed by December 2009.<sup>1</sup> So if you operate a subdomain in `.gov`, you must implement DNSSEC to be compliant. ICANN also requires that all new top-level domains support DNSSEC.
3. *Enhanced Security*: Okay, so the big lofty goal of "let's be good" doesn't appeal to you, and you don't have any compliance standards to worry about. Here is a more practical reason why you should consider DNSSEC: in the event of a DNS-based security breach, such as cache poisoning or domain hijacking, after all the financial and brand damage done to your domain name, you might be placed under scrutiny for any preventive measure that could have been put in place. Think of this like having your website only available via HTTP but not HTTPS.
4. *New Features*: DNSSEC brings not only enhanced security, but also a whole new suite of features. Once DNS can be trusted completely, it becomes possible to publish SSL certificates in DNS, or PGP keys for fully automatic cross-platform email encryption, or SSH fingerprints.... New features are still being developed, but they all rely on a trustworthy DNS infrastructure. To take a peek at these next-generation DNS features, check out *Introduction to DANE*.

---

<sup>1</sup> The Office of Management and Budget (OMB) for the US government published a memo in 2008, requesting all `.gov` subdomains to be DNSSEC-signed by December 2009. This explains why `.gov` is the most-deployed DNSSEC domain currently, with around 90% of subdomains signed.

## 11.2.9 How Does DNSSEC Change My Job as a DNS Administrator?

With this protocol extension, some of the things you were used to in DNS have changed. As the DNS administrator, you have new maintenance tasks to perform on a regular basis (as described in *Maintenance Tasks*); when there is a DNS resolution problem, you have new troubleshooting techniques and tools to use (as described in *Basic DNSSEC Troubleshooting*). BIND 9 tries its best to make these things as transparent and seamless as possible. In this guide, we try to use configuration examples that result in the least amount of work for BIND 9 DNS administrators.

## 11.3 Getting Started

### 11.3.1 Software Requirements

This guide assumes BIND 9.18.0 or newer, although the more elaborate manual procedures do work with all versions of BIND later than 9.9.

We recommend running the latest stable version to get the most complete DNSSEC configuration, as well as the latest security fixes.

### 11.3.2 Hardware Requirements

#### Recursive Server Hardware

Enabling DNSSEC validation on a recursive server makes it a *validating resolver*. The job of a validating resolver is to fetch additional information that can be used to computationally verify the answer set. Contrary to popular belief, the increase in resource consumption is very modest:

1. *CPU*: a validating resolver executes cryptographic functions on cache-miss answers, which leads to increased CPU usage. Thanks to standard DNS caching and contemporary CPUs, the increase in CPU-time consumption in a steady state is negligible - typically on the order of 5%. For a brief period (a few minutes) after the resolver starts, the increase might be as much as 20%, but it quickly decreases as the DNS cache fills in.
2. *System memory*: DNSSEC leads to larger answer sets and occupies more memory space. With typical ISP traffic and the state of the Internet as of mid-2022, memory consumption for the cache increases by roughly 20%.
3. *Network interfaces*: although DNSSEC does increase the amount of DNS traffic overall, in practice this increase is often within measurement error.

#### Authoritative Server Hardware

On the authoritative server side, DNSSEC is enabled on a zone-by-zone basis. When a zone is DNSSEC-enabled, it is also known as "signed." Below are the expected changes to resource consumption caused by serving DNSSEC-signed zones:

1. *CPU*: a DNSSEC-signed zone requires periodic re-signing, which is a cryptographic function that is CPU-intensive. If your DNS zone is dynamic or changes frequently, that also adds to higher CPU loads.
2. *System storage*: A signed zone is definitely larger than an unsigned zone. How much larger? See *Your Zone, Before and After DNSSEC* for a comparison example. The final size depends on the structure of the zone, the signing algorithm, the number of keys, the choice of NSEC or NSEC3, the ratio of signed delegations, the zone file format, etc. Usually, the size of a signed zone ranges from a negligible increase to as much as three times the size of the unsigned zone.
3. *System memory*: Larger DNS zone files take up not only more storage space on the file system, but also more space when they are loaded into system memory. The final memory consumption also depends on all the variables listed above: in the typical case the increase is around half of the unsigned zone memory consumption, but it can be as high as three times for some corner cases.

4. *Network interfaces*: While your authoritative name servers will begin sending back larger responses, it is unlikely that you need to upgrade your network interface card (NIC) on the name server unless you have some truly outdated hardware.

One factor to consider, but over which you really have no control, is the number of users who query your domain name who themselves have DNSSEC enabled. As of mid-2022, measurements by APNIC show 41% of Internet users send DNSSEC-aware queries. This means that more DNS queries for your domain will take advantage of the additional security features, which will result in increased system load and possibly network traffic.

### 11.3.3 Network Requirements

From a network perspective, DNS and DNSSEC packets are very similar; DNSSEC packets are just bigger, which means DNS is more likely to use TCP. You should test for the following two items to make sure your network is ready for DNSSEC:

1. *DNS over TCP*: Verify network connectivity over TCP port 53, which may mean updating firewall policies or Access Control Lists (ACL) on routers. See *Wait... DNS Uses TCP?* for more details.
2. *Large UDP packets*: Some network equipment, such as firewalls, may make assumptions about the size of DNS UDP packets and incorrectly reject DNS traffic that appears "too big." Verify that the responses your name server generates are being seen by the rest of the world: see *What's EDNS All About (And Why Should I Care)?* for more details.

### 11.3.4 Operational Requirements

#### Parent Zone

Before starting your DNSSEC deployment, check with your parent zone administrators to make sure they support DNSSEC. This may or may not be the same entity as your registrar. As you will see later in *Working With the Parent Zone*, a crucial step in DNSSEC deployment is establishing the parent-child trust relationship. If your parent zone does not yet support DNSSEC, contact that administrator to voice your concerns.

#### Security Requirements

Some organizations may be subject to stricter security requirements than others. Check to see if your organization requires stronger cryptographic keys be generated and stored, and how often keys need to be rotated. The examples presented in this document are not intended for high-value zones. We cover some of these security considerations in *Advanced Discussions*.

## 11.4 Validation

### 11.4.1 Easy-Start Guide for Recursive Servers

This section provides the basic information needed to set up a working DNSSEC-aware recursive server, also known as a validating resolver. A validating resolver performs validation for each remote response received, following the chain of trust to verify that the answers it receives are legitimate, through the use of public key cryptography and hashing functions.

#### Enabling DNSSEC Validation

So how do we turn on DNSSEC validation? It turns out that you may not need to reconfigure your name server at all, since the most recent versions of BIND 9 - including packages and distributions - have shipped with DNSSEC validation enabled by default. Before making any configuration changes, check whether you already have DNSSEC validation enabled by following the steps described in *So You Think You Are Validating (How To Test A Recursive Server)*.

In earlier versions of BIND, including 9.11-ESV, DNSSEC validation must be explicitly enabled. To do this, you only need to add one line to the *options* section of your configuration file:

```
options {
    ...
    dnssec-validation auto;
    ...
};
```

Restart *named* or run *rndc reconfig*, and your recursive server is now happily validating each DNS response. If this does not work for you, you may have some other network-related configurations that need to be adjusted. Take a look at *Network Requirements* to make sure your network is ready for DNSSEC.

### Effects of Enabling DNSSEC Validation

Once DNSSEC validation is enabled, any DNS response that does not pass the validation checks results in a failure to resolve the domain name (often a SERVFAIL status seen by the client). If everything has been configured properly, this is the correct result; it means that an end user has been protected against a malicious attack.

However, if there is a DNSSEC configuration issue (sometimes outside of the administrator's control), a specific name or sometimes entire domains may "disappear" from the DNS, and become unreachable through that resolver. For the end user, the issue may manifest itself as name resolution being slow or failing altogether; some parts of a URL not loading; or the web browser returning an error message indicating that the page cannot be displayed. For example, if root name servers were misconfigured with the wrong information about `.org`, it could cause all validation for `.org` domains to fail. To end users, it would appear that all `.org` web sites were out of service.<sup>2</sup> Should you encounter DNSSEC-related problems, don't be tempted to disable validation; there is almost certainly a solution that leaves validation enabled. A basic troubleshooting guide can be found in *Basic DNSSEC Troubleshooting*.

## 11.4.2 So You Think You Are Validating (How To Test A Recursive Server)

Now that you have reconfigured your recursive server and restarted it, how do you know that your recursive name server is actually verifying each DNS query? There are several ways to check, and we've listed a few of them below.

### Using Web-Based Tools to Verify

For most people, the simplest way to check if a recursive name server is indeed validating DNS queries is to use one of the many web-based tools available.

Configure your client computer to use the newly reconfigured recursive server for DNS resolution; then use one of these web-based tests to confirm that it is in fact validating DNS responses.

- [Internet.nl](#)
- [DNSSEC or Not \(VeriSign\)](#)

### Using *dig* to Verify

Web-based DNSSEC-verification tools often employ JavaScript. If you don't trust the JavaScript magic that the web-based tools rely on, you can take matters into your own hands and use a command-line DNS tool to check your validating resolver yourself.

While *nslookup* is popular, partly because it comes pre-installed on most systems, it is not DNSSEC-aware. *dig*, on the other hand, fully supports the DNSSEC standard and comes as a part of BIND. If you do not have *dig* already installed on your system, install it by downloading it from ISC's [website](#). ISC provides pre-compiled Windows versions on its website.

<sup>2</sup> Of course, something like this could happen for reasons other than DNSSEC: for example, the root publishing the wrong addresses for the `.org` nameservers.

*dig* is a flexible tool for interrogating DNS name servers. It performs DNS lookups and displays the answers that are returned from the name servers that were queried. Most seasoned DNS administrators use *dig* to troubleshoot DNS problems because of its flexibility, ease of use, and clarity of output.

The example below shows how to use *dig* to query the name server 10.53.0.1 for the A record for `ftp.isc.org` when DNSSEC validation is enabled (i.e. the default). The address 10.53.0.1 is only used as an example; replace it with the actual address or host name of your recursive name server.

```
$ dig @10.53.0.1 ftp.isc.org. A +dnssec +multiline

; <<>> DiG 9.16.0 <<>> @10.53.0.1 ftp.isc.org a +dnssec +multiline
; (1 server found)
; global options: +cmd
; Got answer:
; ->>HEADER<<- opcode: QUERY, status: NOERROR, id: 48742
; flags: qr rd ra ad; QUERY: 1, ANSWER: 2, AUTHORITY: 0, ADDITIONAL: 1

; OPT PSEUDOSECTION:
; EDNS: version: 0, flags: do; udp: 4096
; COOKIE: 29a9705c2160b08c010000005e67a4a102b9ae079c1b24c8 (good)
; QUESTION SECTION:
;ftp.isc.org.          IN A

; ANSWER SECTION:
ftp.isc.org.          300 IN A 149.20.1.49
ftp.isc.org.          300 IN RRSIG A 13 3 300 (
                        20200401191851 20200302184340 27566 isc.org.
                        e9Vkb6/6aHMqk/t23Im71ioiDUhB06snscduoW9+Asl4
                        L3TZtpLvZ5+zudTJC2coI4D/D9AXte1cD6FV6iS6PQ== )

; Query time: 452 msec
; SERVER: 10.53.0.1#53(10.53.0.1)
; WHEN: Tue Mar 10 14:30:57 GMT 2020
; MSG SIZE rcvd: 187
```

The important detail in this output is the presence of the `ad` flag in the header. This signifies that BIND has retrieved all related DNSSEC information related to the target of the query (`ftp.isc.org`) and that the answer received has passed the validation process described in *How Are Answers Verified?*. We can have confidence in the authenticity and integrity of the answer, that `ftp.isc.org` really points to the IP address 149.20.1.49, and that it was not a spoofed answer from a clever attacker.

Unlike earlier versions of BIND, the current versions of BIND always request DNSSEC records (by setting the `do` bit in the query they make to upstream servers), regardless of DNSSEC settings. However, with validation disabled, the returned signature is not checked. This can be seen by explicitly disabling DNSSEC validation. To do this, add the line `dnssec-validation no;` to the "options" section of the configuration file, i.e.:

```
options {
    ...
    dnssec-validation no;
    ...
};
```

If the server is restarted (to ensure a clean cache) and the same *dig* command executed, the result is very similar:

```

$ dig @10.53.0.1 ftp.isc.org. A +dnssec +multiline

; <<>> DiG 9.16.0 <<>> @10.53.0.1 ftp.isc.org a +dnssec +multiline
; (1 server found)
;; global options: +cmd
;; Got answer:
;; ->>HEADER<<- opcode: QUERY, status: NOERROR, id: 39050
;; flags: qr rd ra; QUERY: 1, ANSWER: 2, AUTHORITY: 0, ADDITIONAL: 1

;; OPT PSEUDOSECTION:
; EDNS: version: 0, flags: do; udp: 4096
; COOKIE: a8dc9d1b9ec45e75010000005e67a8a69399741fdb126f2 (good)
;; QUESTION SECTION:
;ftp.isc.org.          IN A

;; ANSWER SECTION:
ftp.isc.org.          300 IN A 149.20.1.49
ftp.isc.org.          300 IN RRSIG A 13 3 300 (
                        20200401191851 20200302184340 27566 isc.org.
                        e9Vkb6/6aHMQk/t23Im71ioiDUhB06sncsduoW9+Asl4
                        L3TZtpLvZ5+zudTJC2coI4D/D9AXte1cD6FV6iS6PQ== )

;; Query time: 261 msec
;; SERVER: 10.53.0.1#53(10.53.0.1)
;; WHEN: Tue Mar 10 14:48:06 GMT 2020
;; MSG SIZE rcvd: 187

```

However, this time there is no `ad` flag in the header. Although `dig` is still returning the DNSSEC-related resource records, it is not checking them, and thus cannot vouch for the authenticity of the answer. If you do carry out this test, remember to re-enable DNSSEC validation (by removing the `dnssec-validation no;` line from the configuration file) before continuing.

### 11.4.3 Verifying Protection From Bad Domain Names

It is also important to make sure that DNSSEC is protecting your network from domain names that fail to validate; such failures could be caused by attacks on your system, attempting to get it to accept false DNS information. Validation could fail for a number of reasons: maybe the answer doesn't verify because it's a spoofed response; maybe the signature was a replayed network attack that has expired; or maybe the child zone has been compromised along with its keys, and the parent zone's information tells us that things don't add up. There is a domain name specifically set up to fail DNSSEC validation, [www.dnssec-failed.org](http://www.dnssec-failed.org).

With DNSSEC validation enabled (the default), an attempt to look up that name fails:

```

$ dig @10.53.0.1 www.dnssec-failed.org. A

; <<>> DiG 9.16.0 <<>> @10.53.0.1 www.dnssec-failed.org. A
; (1 server found)
;; global options: +cmd
;; Got answer:
;; ->>HEADER<<- opcode: QUERY, status: SERVFAIL, id: 22667
;; flags: qr rd ra; QUERY: 1, ANSWER: 0, AUTHORITY: 0, ADDITIONAL: 1

;; OPT PSEUDOSECTION:

```

(continues on next page)

(continued from previous page)

```

; EDNS: version: 0, flags;; udp: 4096
; COOKIE: 69c3083144854587010000005e67bb57f5f90ff2688e455d (good)
;; QUESTION SECTION:
;www.dnssec-failed.org.      IN  A

;; Query time: 2763 msec
;; SERVER: 10.53.0.1#53(10.53.0.1)
;; WHEN: Tue Mar 10 16:07:51 GMT 2020
;; MSG SIZE  rcvd: 78

```

On the other hand, if DNSSEC validation is disabled (by adding the statement `dnssec-validation no;` to the `options` clause in the configuration file), the lookup succeeds:

```

$ dig @10.53.0.1 www.dnssec-failed.org. A

; <<>> DiG 9.16.0 <<>> @10.53.0.1 www.dnssec-failed.org. A
; (1 server found)
;; global options: +cmd
;; Got answer:
;; ->>HEADER<<- opcode: QUERY, status: NOERROR, id: 54704
;; flags: qr rd ra; QUERY: 1, ANSWER: 2, AUTHORITY: 0, ADDITIONAL: 1

;; OPT PSEUDOSECTION:
; EDNS: version: 0, flags;; udp: 4096
; COOKIE: 251eee58208917f9010000005e67bb6829f6dabc5ae6b7b9 (good)
;; QUESTION SECTION:
;www.dnssec-failed.org.      IN  A

;; ANSWER SECTION:
www.dnssec-failed.org.  7200      IN  A    68.87.109.242
www.dnssec-failed.org.  7200      IN  A    69.252.193.191

;; Query time: 439 msec
;; SERVER: 10.53.0.1#53(10.53.0.1)
;; WHEN: Tue Mar 10 16:08:08 GMT 2020
;; MSG SIZE  rcvd: 110

```

Do not be tempted to disable DNSSEC validation just because some names are failing to resolve. Remember, DNSSEC protects your DNS lookup from hacking. The next section describes how to quickly check whether the failure to successfully look up a name is due to a validation failure.

**How Do I Know I Have a Validation Problem?**

Since all DNSSEC validation failures result in a general `SERVFAIL` message, how do we know if it was really a validation error? Fortunately, there is a flag in `dig`, ("CD" for "checking disabled") which tells the server to disable DNSSEC validation. If you receive a `SERVFAIL` message, re-run the query a second time and set the `dig +cd` flag. If the query succeeds with `dig +cd`, but ends in `SERVFAIL` without it, you know you are dealing with a validation problem. So using the previous example of `www.dnssec-failed.org` and with DNSSEC validation enabled in the resolver:

```

$ dig @10.53.0.1 www.dnssec-failed.org A +cd

; <<>> DiG 9.16.0 <<>> @10.53.0.1 www.dnssec-failed.org. A +cd
; (1 server found)

```

(continues on next page)

(continued from previous page)

```
;; global options: +cmd
;; Got answer:
;; ->>HEADER<<- opcode: QUERY, status: NOERROR, id: 62313
;; flags: qr rd ra cd; QUERY: 1, ANSWER: 2, AUTHORITY: 0, ADDITIONAL: 1

;; OPT PSEUDOSECTION:
; EDNS: version: 0, flags;; udp: 4096
; COOKIE: 73ca1be3a74dd2cf010000005e67c8c8e6df64b519cd87fd (good)
;; QUESTION SECTION:
;www.dnssec-failed.org.      IN  A

;; ANSWER SECTION:
www.dnssec-failed.org.  7197      IN  A    68.87.109.242
www.dnssec-failed.org.  7197      IN  A    69.252.193.191

;; Query time: 0 msec
;; SERVER: 10.53.0.1#53(10.53.0.1)
;; WHEN: Tue Mar 10 17:05:12 GMT 2020
;; MSG SIZE rcvd: 110
```

For more information on troubleshooting, please see *Basic DNSSEC Troubleshooting*.

#### 11.4.4 Validation Easy Start Explained

In *Easy-Start Guide for Recursive Servers*, we used one line of configuration to turn on DNSSEC validation: the act of chasing down signatures and keys, making sure they are authentic. Now we are going to take a closer look at what DNSSEC validation actually does, and some other options.

##### *dnssec-validation*

```
options {
    dnssec-validation auto;
};
```

This “auto” line enables automatic DNSSEC trust anchor configuration using the *managed-keys* feature. In this case, no manual key configuration is needed. There are three possible choices for the *dnssec-validation* option:

- *yes*: DNSSEC validation is enabled, but a trust anchor must be manually configured. No validation actually takes place until at least one trusted key has been manually configured.
- *no*: DNSSEC validation is disabled, and the recursive server behaves in the “old-fashioned” way of performing insecure DNS lookups.
- *auto*: DNSSEC validation is enabled, and a default trust anchor (included as part of BIND 9) for the DNS root zone is used. This is the default; BIND automatically does this if there is no *dnssec-validation* line in the configuration file.

Let's discuss the difference between *yes* and *auto*. If set to *yes*, the trust anchor must be manually defined and maintained using the *trust-anchors* statement (with either the *static-key* or *static-ds* modifier) in the configuration file; if set to *auto* (the default, and as shown in the example), then no further action should be required as BIND includes a copy<sup>4</sup> of the root key. When set to *auto*, BIND automatically keeps the keys (also known as trust anchors, discussed in *Trust Anchors*) up-to-date without intervention from the DNS administrator.

<sup>4</sup> The root zone was signed in July 2010 and, as at the time of this writing (mid-2020), the key has been changed once, in October 2018. The intention going forward is to roll the key once every five years.

We recommend using the default *auto* unless there is a good reason to require a manual trust anchor. To learn more about trust anchors, please refer to *Trusted Keys and Managed Keys*.

### How Does DNSSEC Change DNS Lookup (Revisited)?

Now you've enabled validation on your recursive name server and verified that it works. What exactly changed? In *How Does DNSSEC Change DNS Lookup?* we looked at a very high-level, simplified version of the 12 steps of the DNSSEC validation process. Let's revisit that process now and see what your validating resolver is doing in more detail. Again, as an example we are looking up the A record for the domain name `www.isc.org` (see *The 12-Step DNSSEC Validation Process (Simplified)*):

1. The validating resolver queries the `isc.org` name servers for the A record of `www.isc.org`. This query has the DNSSEC OK (do) bit set to 1, notifying the remote authoritative server that DNSSEC answers are desired.
2. Since the zone `isc.org` is signed, and its name servers are DNSSEC-aware, it responds with the answer to the A record query plus the RRSIG for the A record.
3. The validating resolver queries for the DNSKEY for `isc.org`.
4. The `isc.org` name server responds with the DNSKEY and RRSIG records. The DNSKEY is used to verify the answers received in #2.
5. The validating resolver queries the parent (`.org`) for the DS record for `isc.org`.
6. The `.org` name server is also DNSSEC-aware, so it responds with the DS and RRSIG records. The DS record is used to verify the answers received in #4.
7. The validating resolver queries for the DNSKEY for `.org`.
8. The `.org` name server responds with its DNSKEY and RRSIG. The DNSKEY is used to verify the answers received in #6.
9. The validating resolver queries the parent (root) for the DS record for `.org`.
10. The root name server, being DNSSEC-aware, responds with DS and RRSIG records. The DS record is used to verify the answers received in #8.
11. The validating resolver queries for the DNSKEY for root.
12. The root name server responds with its DNSKEY and RRSIG. The DNSKEY is used to verify the answers received in #10.

After step #12, the validating resolver takes the DNSKEY received and compares it to the key or keys it has configured, to decide whether the received key can be trusted. We talk about these locally configured keys, or trust anchors, in *Trust Anchors*.

With DNSSEC, every response includes not just the answer, but a digital signature (RRSIG) as well, so the validating resolver can verify the answer received. That is what we look at in the next section, *How Are Answers Verified?*.

### How Are Answers Verified?

#### Note

Keep in mind, as you read this section, that although words like "encryption" and "decryption" are used here from time to time, DNSSEC does not provide privacy. Public key cryptography is used to verify data *authenticity* (who sent it) and data *integrity* (it did not change during transit), but any eavesdropper can still see DNS requests and responses in clear text, even when DNSSEC is enabled.

So how exactly are DNSSEC answers verified? Let's first see how verifiable information is generated. On the authoritative server, each DNS record (or message) is run through a hash function, and this hashed value is then encrypted by a private key. This encrypted hash value is the digital signature.

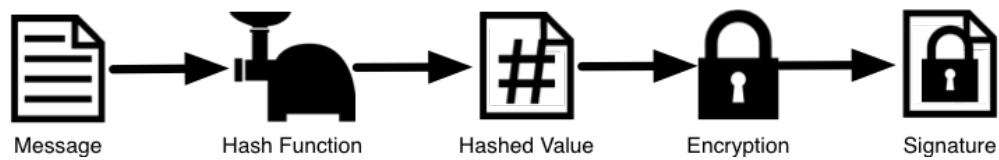

Fig. 1: Signature Generation

When the validating resolver queries for the resource record, it receives both the plain-text message and the digital signature(s). The validating resolver knows the hash function used (it is listed in the digital signature record itself), so it can take the plain-text message and run it through the same hash function to produce a hashed value, which we'll call hash value X. The validating resolver can also obtain the public key (published as DNSKEY records), decrypt the digital signature, and get back the original hashed value produced by the authoritative server, which we'll call hash value Y. If hash values X and Y are identical, and the time is correct (more on what this means below), the answer is verified, meaning this answer came from the authoritative server (authenticity), and the content remained intact during transit (integrity).

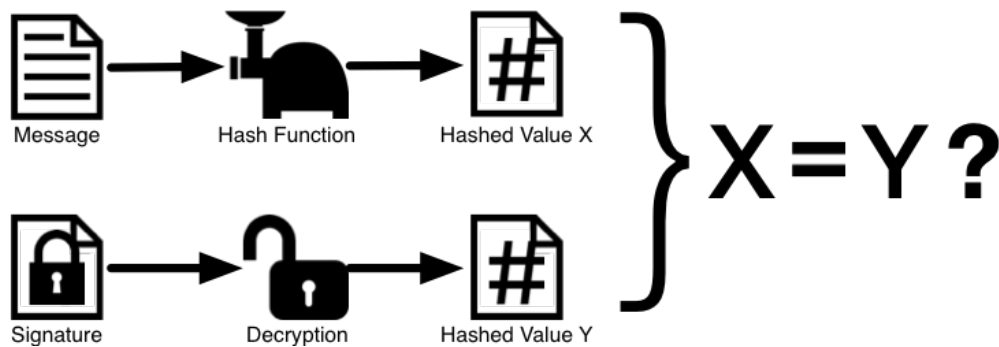

Fig. 2: Signature Verification

Take the A record `ftp.isc.org`, for example. The plain text is:

```
ftp.isc.org.      4 IN A  149.20.1.49
```

The digital signature portion is:

```
ftp.isc.org.      300 IN RRSIG A 13 3 300 (
20200401191851 20200302184340 27566 isc.org.
e9Vkb6/6aHMqk/t23Im71ioiDUhB06sncsduoW9+Asl4
L3TZtpLvZ5+zudTJC2coI4D/D9AXte1cD6FV6iS6PQ== )
```

When a validating resolver queries for the A record `ftp.isc.org`, it receives both the A record and the RRSIG record. It runs the A record through a hash function (in this example, SHA256 as indicated by the number 13, signifying ECD-SAP256SHA256) and produces hash value X. The resolver also fetches the appropriate DNSKEY record to decrypt the signature, and the result of the decryption is hash value Y.

But wait, there's more! Just because X equals Y doesn't mean everything is good. We still have to look at the time. Remember we mentioned a little earlier that we need to check if the time is correct? Look at the two timestamps in our example above:

- Signature Expiration: 20200401191851
- Signature Inception: 20200302184340

This tells us that this signature was generated UTC March 2nd, 2020, at 6:43:40 PM (20200302184340), and it is good until UTC April 1st, 2020, 7:18:51 PM (20200401191851). The validating resolver's current system time needs to fall between these two timestamps. If it does not, the validation fails, because it could be an attacker replaying an old captured answer set from the past, or feeding us a crafted one with incorrect future timestamps.

If the answer passes both the hash value check and the timestamp check, it is validated and the authenticated data (`ad`) bit is set, and the response is sent to the client; if it does not verify, a `SERVFAIL` is returned to the client.

### 11.4.5 Trust Anchors

A trust anchor is a key that is placed into a validating resolver, so that the validator can verify the results of a given request with a known or trusted public key (the trust anchor). A validating resolver must have at least one trust anchor installed to perform DNSSEC validation.

### 11.4.6 How Trust Anchors are Used

In the section *How Does DNSSEC Change DNS Lookup (Revisited)?*, we walked through the 12 steps of the DNSSEC lookup process. At the end of the 12 steps, a critical comparison happens: the key received from the remote server and the key we have on file are compared to see if we trust it. The key we have on file is called a trust anchor, sometimes also known as a trust key, trust point, or secure entry point.

The 12-step lookup process describes the DNSSEC lookup in the ideal world, where every single domain name is signed and properly delegated, and where each validating resolver only needs to have one trust anchor - that is, the root's public key. But there is no restriction that the validating resolver must only have one trust anchor. In fact, in the early stages of DNSSEC adoption, it was not unusual for a validating resolver to have more than one trust anchor.

For instance, before the root zone was signed (in July 2010), some validating resolvers that wished to validate domain names in the `.gov` zone needed to obtain and install the key for `.gov`. A sample lookup process for `www.fbi.gov` at that time would have been eight steps rather than 12:

1. The validating resolver queried `fbi.gov` name server for the A record of `www.fbi.gov`.
2. The FBI's name server responded with the answer and its RRSIG.
3. The validating resolver queried the FBI's name server for its DNSKEY.
4. The FBI's name server responded with the DNSKEY and its RRSIG.
5. The validating resolver queried a `.gov` name server for the DS record of `fbi.gov`.
6. The `.gov` name server responded with the DS record and the associated RRSIG for `fbi.gov`.
7. The validating resolver queried the `.gov` name server for its DNSKEY.
8. The `.gov` name server responded with its DNSKEY and the associated RRSIG.

This all looks very similar, except it's shorter than the 12 steps that we saw earlier. Once the validating resolver receives the DNSKEY file in #8, it recognizes that this is the manually configured trusted key (trust anchor), and never goes to the root name servers to ask for the DS record for `.gov`, or ask the root name servers for their DNSKEY.

In fact, whenever the validating resolver receives a DNSKEY, it checks to see if this is a configured trusted key to decide whether it needs to continue chasing down the validation chain.

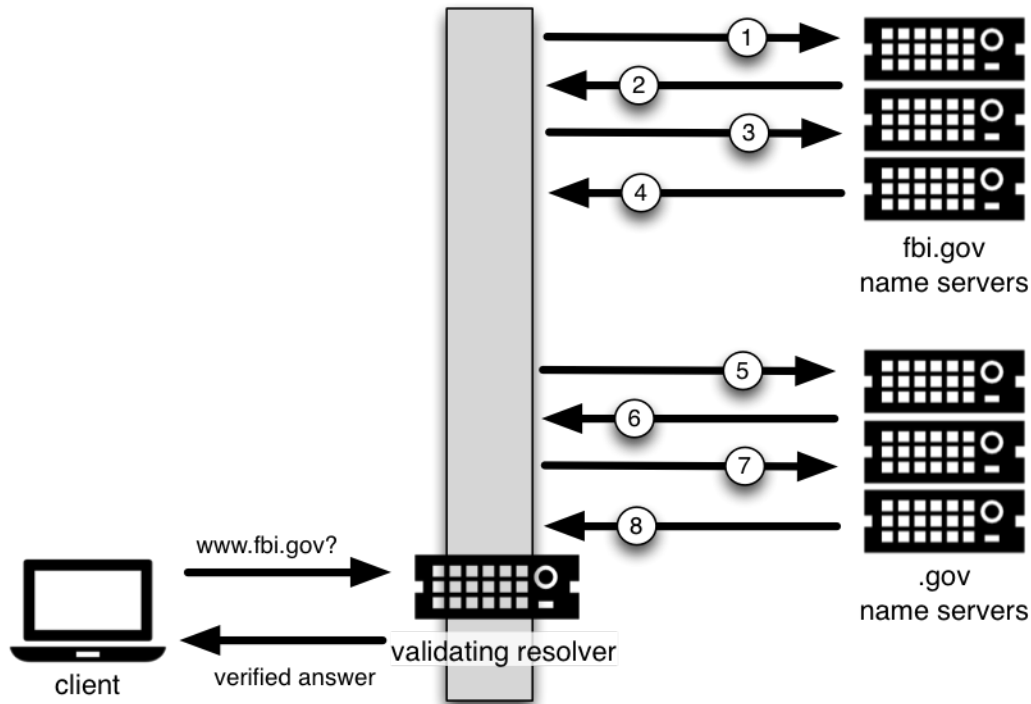

### Trusted Keys and Managed Keys

Since the resolver is validating, we must have at least one key (trust anchor) configured. How did it get here, and how do we maintain it?

If you followed the recommendation in *Easy-Start Guide for Recursive Servers*, by setting `dnssec-validation` to `auto`, there is nothing left to do. BIND already includes a copy of the root key (in the file `bind.keys`),<sup>3</sup> and automatically updates it when the root key changes.<sup>Page 341, 4</sup> It looks something like this:

```
trust-anchors {
    # This key (20326) was published in the root zone in 2017.
    . initial-key 257 3 8 "AwEAAaz/
    ↪tAm8yTn4Mfeh5eyI96WSVexTBAvkMgJzkKTOiW1vkIbzxef3
      +/4RgWOq7HrxRixH1FlExOLAJr5emLvN7SWXgnLh4+B5xQ1NVz8Og8kv
      ArMtNROxVQuCaSnIDdD5LKyWbRd2n9WGe2R8PzgCmr3EgVLRjyBxWezF
      0jLHwVN8efS3rCj/EWgvIWgb9tarpVUDK/b58Da+sqqls3eNbuV7pr+e
      oZG+SrdK6nWeL3c6H5Apxz7LjVc1uTIdsIXxuOLYA4/ilBmSVIzuDWfd
      RUfhHdY6+cn8HFRm+2hM8AnXGXws9555KrUB5qihylGa8subX2Nn6UwN
      R1AkUTV74bU=";
};
```

You can, of course, decide to manage this key manually yourself. First, you need to make sure that `dnssec-validation` is set to `yes` rather than `auto`:

```
options {
    dnssec-validation yes;
};
```

<sup>3</sup> BIND technically includes two copies of the root key: one is in `bind.keys.h` and is built into the executable, and one is in `bind.keys` as a `trust-anchors` statement. The two copies of the key are identical.

Then, download the root key manually from a trustworthy source, such as <https://www.isc.org/bind-keys>. Finally, take the root key you manually downloaded and put it into a `trust-anchors` statement as shown below:

```
trust-anchors {
    # This key (20326) was published in the root zone in 2017.
    . static-key 257 3 8 "AwEAAaz/tAm8yTn4Mfeh5eyI96WSVexTBAvkMgJzkKTOiW1vkIbzxeF3
        +/4RgWOq7HrxRixHlFlExOLAJr5emLvN7SWXgnLh4+B5xQ1NVz8Og8kv
        ArMtNROxVQuCaSnIDd5LKyWbRd2n9WGe2R8PzqCmr3EgVLRjyBxWezF
        0jLHwVN8efS3rCj/EWgvIWgb9tarpVUDK/b58Da+sqqls3eNbuV7pr+e
        oZG+SrDK6nWeL3c6H5Apzz7LjVc1uTIdsIXxuOLYA4/ilBmSVIzuDWfd
        RUfhHdY6+cn8HFRm+2hM8AnXGXws9555KrUB5qihylGa8subX2Nn6UwN
        R1AkUTV74bU=";
};
```

While this `trust-anchors` statement and the one in the `bind.keys` file appear similar, the definition of the key in `bind.keys` has the `initial-key` modifier, whereas in the statement in the configuration file, that is replaced by `static-key`. There is an important difference between the two: a key defined with `static-key` is always trusted until it is deleted from the configuration file. With the `initial-key` modified, keys are only trusted once: for as long as it takes to load the managed key database and start the key maintenance process. Thereafter, BIND uses the managed keys database (`managed-keys.bind.jnl`) as the source of key information.

### Warning

Remember, if you choose to manage the keys on your own, whenever the key changes (which, for most zones, happens on a periodic basis), the configuration needs to be updated manually. Failure to do so will result in breaking nearly all DNS queries for the subdomain of the key. So if you are manually managing `.gov`, all domain names in the `.gov` space may become unresolvable; if you are manually managing the root key, you could break all DNS requests made to your recursive name server.

Explicit management of keys was common in the early days of DNSSEC, when neither the root zone nor many top-level domains were signed. Since then, over 90% of the top-level domains have been signed, including all the largest ones. Unless you have a particular need to manage keys yourself, it is best to use the BIND defaults and let the software manage the root key.

## 11.4.7 What's EDNS All About (And Why Should I Care)?

### EDNS Overview

Traditional DNS responses are typically small in size (less than 512 bytes) and fit nicely into a small UDP packet. The Extension mechanism for DNS (EDNS, or EDNS(0)) offers a mechanism to send DNS data in larger packets over UDP. To support EDNS, both the DNS server and the network need to be properly prepared to support the larger packet sizes and multiple fragments.

This is important for DNSSEC, since the `dig +do` bit that signals DNSSEC-awareness is carried within EDNS, and DNSSEC responses are larger than traditional DNS ones. If DNS servers and the network environment cannot support large UDP packets, it will cause retransmission over TCP, or the larger UDP responses will be discarded. Users will likely experience slow DNS resolution or be unable to resolve certain names at all.

Note that EDNS applies regardless of whether you are validating DNSSEC, because BIND has DNSSEC enabled by default.

Please see [Network Requirements](#) for more information on what DNSSEC expects from the network environment.

## EDNS on DNS Servers

For many years, BIND has had EDNS enabled by default, and the UDP packet size is set to a maximum of 4096 bytes. The DNS administrator should not need to perform any reconfiguration. You can use *dig* to verify that your server supports EDNS and see the UDP packet size it allows with this *dig* command:

```
$ dig @10.53.0.1 www.isc.org. A +dnssec +multiline

; <<>> DiG 9.16.0 <<>> @10.53.0.1 ftp.isc.org a +dnssec +multiline
; (1 server found)
;; global options: +cmd
;; Got answer:
;; ->>HEADER<<- opcode: QUERY, status: NOERROR, id: 48742
;; flags: qr rd ra ad; QUERY: 1, ANSWER: 2, AUTHORITY: 0, ADDITIONAL: 1

;; OPT PSEUDOSECTION:
; EDNS: version: 0, flags: do; udp: 4096
; COOKIE: 29a9705c2160b08c010000005e67a4a102b9ae079c1b24c8 (good)
;; QUESTION SECTION:
;ftp.isc.org.          IN A

;; ANSWER SECTION:
ftp.isc.org.          300 IN A 149.20.1.49
ftp.isc.org.          300 IN RRSIG A 13 3 300 (
                        20200401191851 20200302184340 27566 isc.org.
                        e9Vkb6/6aHMqk/t23Im71ioiDUhB06sncsduoW9+Asl4
                        L3TZtpLvZ5+zudTJC2coI4D/D9AXte1cD6FV6iS6PQ== )

;; Query time: 452 msec
;; SERVER: 10.53.0.1#53(10.53.0.1)
;; WHEN: Tue Mar 10 14:30:57 GMT 2020
;; MSG SIZE rcvd: 187
```

There is a helpful testing tool available (provided by DNS-OARC) that you can use to verify resolver behavior regarding EDNS support: <https://www.dns-oarc.net/oarc/services/replysizetest/>.

Once you've verified that your name servers have EDNS enabled, that should be the end of the story, right? Unfortunately, EDNS is a hop-by-hop extension to DNS. This means the use of EDNS is negotiated between each pair of hosts in a DNS resolution process, which in turn means if one of your upstream name servers (for instance, your ISP's recursive name server that your name server forwards to) does not support EDNS, you may experience DNS lookup failures or be unable to perform DNSSEC validation.

## Support for Large Packets on Network Equipment

If both your recursive name server and your ISP's name servers support EDNS, we are all good here, right? Not so fast. Since these large packets have to traverse the network, the network infrastructure itself must allow them to pass.

When data is physically transmitted over a network, it has to be broken down into chunks. The size of the data chunk is known as the Maximum Transmission Unit (MTU), and it can differ from network to network. IP fragmentation occurs when a large data packet needs to be broken down into chunks smaller than the MTU; these smaller chunks then need to be reassembled back into the large data packet at their destination. IP fragmentation is not necessarily a bad thing, and it most likely occurs on your network today.

Some network equipment, such as a firewall, may make assumptions about DNS traffic. One of these assumptions may be how large each DNS packet is. When a firewall sees a larger DNS packet than it expects, it may either reject the large packet or drop its fragments because the firewall thinks it's an attack. This configuration probably didn't cause problems

in the past, since traditional DNS packets are usually pretty small in size. However, with DNSSEC, these configurations need to be updated, since DNSSEC traffic regularly exceeds 1500 bytes (a common MTU value). If the configuration is not updated to support a larger DNS packet size, it often results in the larger packets being rejected, and to the end user it looks like the queries go unanswered. Or in the case of fragmentation, only a part of the answer makes it to the validating resolver, and your validating resolver may need to re-ask the question again and again, creating the appearance for end users that the DNS/network is slow.

While you are updating the configuration on your network equipment, make sure TCP port 53 is also allowed for DNS traffic.

### Wait... DNS Uses TCP?

Yes. DNS uses TCP port 53 as a fallback mechanism, when it cannot use UDP to transmit data. This has always been the case, even long before the arrival of DNSSEC. Traditional DNS relies on TCP port 53 for operations such as zone transfer. The use of DNSSEC, or DNS with IPv6 records such as AAAA, increases the chance that DNS data will be transmitted via TCP.

Due to the increased packet size, DNSSEC may fall back to TCP more often than traditional (insecure) DNS. If your network blocks or filters TCP port 53 today, you may already experience instability with DNS resolution, before even deploying DNSSEC.

## 11.5 Signing

### 11.5.1 Easy-Start Guide for Signing Authoritative Zones

This section provides the basic information needed to set up a DNSSEC-enabled authoritative name server. A DNSSEC-enabled (or "signed") zone contains additional resource records that are used to verify the authenticity of its zone information.

To convert a traditional (insecure) DNS zone to a secure one, we need to create some additional records (DNSKEY, RRSIG, and NSEC or NSEC3), and upload verifiable information (such as a DS record) to the parent zone to complete the chain of trust. For more information about DNSSEC resource records, please see *What Does DNSSEC Add to DNS?*.

#### Note

In this chapter, we assume all configuration files, key files, and zone files are stored in `/etc/bind`, and most examples show commands run as the root user. This may not be ideal, but the point is not to distract from what is important here: learning how to sign a zone. There are many best practices for deploying a more secure BIND installation, with techniques such as jailed process and restricted user privileges, but those are not covered in this document. We trust you, a responsible DNS administrator, to take the necessary precautions to secure your system.

For the examples below, we work with the assumption that there is an existing insecure zone `example.com` that we are converting to a secure zone.

### Enabling Automated DNSSEC Zone Maintenance and Key Generation

To sign a zone, add the following statement to its `zone` clause in the BIND 9 configuration file:

```
options {
    directory "/etc/bind";
    recursion no;
    ...
};
```

(continues on next page)

(continued from previous page)

```
zone "example.com" in {
    ...
    dnssec-policy default;
    inline-signing yes;
    ...
};
```

The `dnssec-policy` statement causes the zone to be signed and turns on automatic maintenance for the zone. This includes re-signing the zone as signatures expire and replacing keys on a periodic basis. The value `default` selects the default policy, which contains values suitable for most situations. We cover the creation of a custom policy in [Creating a Custom DNSSEC Policy](#), but for the moment we are accepting the default values.

Using `dnssec-policy` requires dynamic DNS or `inline-signing` to be enabled.

### Note

Previously, if a zone with a `dnssec-policy` did not have dynamic DNS set up and `inline-signing` was not explicitly set, BIND 9 used `inline-signing` implicitly. But this caused a lot of problems when operators switched on or off dynamic DNS for their zones. Therefore, you now have to configure it explicitly.

When the configuration file is updated, tell `named` to reload the configuration file by running `rndc reconfig`:

```
# rndc reconfig
```

And that's it - BIND signs your zone.

At this point, before you go away and merrily add `dnssec-policy` statements to all your zones, we should mention that, like a number of other BIND configuration options, its scope depends on where it is placed. In the example above, we placed it in a `zone` clause, so it applied only to the zone in question. If we had placed it in a `view` clause, it would have applied to all zones in the view; and if we had placed it in the `options` clause, it would have applied to all zones served by this instance of BIND.

## Verification

The BIND 9 reconfiguration starts the process of signing the zone. First, it generates a key for the zone and includes it in the published zone. The log file shows messages such as these:

```
07-Apr-2020 16:02:55.045 zone example.com/IN (signed): reconfiguring zone keys
07-Apr-2020 16:02:55.045 reloading configuration succeeded
07-Apr-2020 16:02:55.046 keymgr: DNSKEY example.com/ECDSAP256SHA256/10376 (CSK)
↳created for policy default
07-Apr-2020 16:02:55.046 Fetching example.com/ECDSAP256SHA256/10376 (CSK) from key
↳repository.
07-Apr-2020 16:02:55.046 DNSKEY example.com/ECDSAP256SHA256/10376 (CSK) is now
↳published
07-Apr-2020 16:02:55.046 DNSKEY example.com/ECDSAP256SHA256/10376 (CSK) is now active
07-Apr-2020 16:02:55.048 zone example.com/IN (signed): next key event: 07-Apr-2020
↳18:07:55.045
```

It then starts signing the zone. How long this process takes depends on the size of the zone, the speed of the server, and how much activity is taking place. We can check what is happening by using `rndc`, entering the command:

```
# rndc signing -list example.com
```

While the signing is in progress, the output is something like:

```
Signing with key 10376/ECDSAP256SHA256
```

and when it is finished:

```
Done signing with key 10376/ECDSAP256SHA256
```

When the second message appears, the zone is signed.

Before moving on to the next step of coordinating with the parent zone, let's make sure everything looks good using *delv*. We want to simulate what a validating resolver will check, by telling *delv* to use a specific trust anchor.

First, we need to make a copy of the key created by BIND. This is in the directory you set with the *directory* statement in your configuration file's *options* clause, and is named something like `Kexample.com.+013.10376.key`:

```
# cp /etc/bind/Kexample.com.+013+10376.key /tmp/example.key
```

The original key file looks like this (with the actual key shortened for ease of display, and comments omitted):

```
# cat /etc/bind/Kexample.com.+013+10376.key
...
example.com. 3600 IN DNSKEY 257 3 13 6saiq99qDB...dqp+o0dw==
```

We want to edit the copy to be in the *trust-anchors* format, so that it looks like this:

```
# cat /tmp/example.key
trust-anchors {
    example.com. static-key 257 3 13 "6saiq99qDB...dqp+o0dw==";
};
```

Now we can run the *delv* command and instruct it to use this trusted-key file to validate the answer it receives from the authoritative name server 192.168.1.13:

```
$ delv @192.168.1.13 -a /tmp/example.key +root=example.com example.com. SOA +multiline
; fully validated
example.com.          600 IN SOA ns1.example.com. admin.example.com. (
                        2020040703 ; serial
                        1800       ; refresh (30 minutes)
                        900        ; retry (15 minutes)
                        2419200    ; expire (4 weeks)
                        300        ; minimum (5 minutes)
                        )
example.com.          600 IN RRSIG SOA 13 2 600 (
                        20200421150255 20200407140255 10376 example.com.
                        jBsz92zwAcGMNV/yu167aKQZvFyC7BiQe1WEnlogdLTF
                        oq4yBQumOhO5WX61LjA17l1DuLWcd/ASwlUZWFQCYQ== )
```

## Uploading Information to the Parent Zone

Once everything is complete on our name server, we need to generate some information to be uploaded to the parent zone to complete the chain of trust. The format and the upload methods are actually dictated by your parent zone's administrator, so contact your registrar or parent zone administrator to find out what the actual format should be and how to deliver or upload the information to the parent zone.

What about your zone between the time you signed it and the time your parent zone accepts the upload? To the rest of the world, your zone still appears to be insecure, because if a validating resolver attempts to validate your domain name via your parent zone, your parent zone will indicate that you are not yet signed (as far as it knows). The validating resolver will then give up attempting to validate your domain name, and will fall back to the insecure DNS. Until you complete this final step with your parent zone, your zone remains insecure.

### Note

Before uploading to your parent zone, verify that your newly signed zone has propagated to all of your name servers (usually via zone transfers). If some of your name servers still have unsigned zone data while the parent tells the world it should be signed, validating resolvers around the world cannot resolve your domain name.

Here are some examples of what you may upload to your parent zone, with the DNSKEY/DS data shortened for display. Note that no matter what format may be required, the end result is the parent zone publishing DS record(s) based on the information you upload. Again, contact your parent zone administrator(s) to find out the correct format for their system.

1. DS record format:

```
example.com. 3600 IN DS 10376 13 2 B92E22CAE0...33B8312EF0
```

2. DNSKEY format:

```
example.com. 3600 IN DNSKEY 257 3 13 6saiq99qDB...dqp+o0dw==
```

The DS record format may be generated from the DNSKEY using the `dnssec-dsfromkey` tool, which is covered in *DS Record Format*. For more details and examples on how to work with your parent zone, please see *Working With the Parent Zone*.

## So... What Now?

Congratulations! Your zone is signed, your secondary servers have received the new zone data, and the parent zone has accepted your upload and published your DS record. Your zone is now officially DNSSEC-enabled. What happens next? That is basically it - BIND takes care of everything else. As for updating your zone file, you can continue to update it the same way as prior to signing your zone; the normal work flow of editing a zone file and using the `rndc` command to reload the zone still works as usual, and although you are editing the unsigned version of the zone, BIND generates the signed version automatically.

Curious as to what all these commands did to your zone file? Read on to *Your Zone, Before and After DNSSEC* and find out. If you are interested in how to roll this out to your existing primary and secondary name servers, check out *DNSSEC Signing* in the *Recipes* chapter.

### 11.5.2 Your Zone, Before and After DNSSEC

When we assigned the default DNSSEC policy to the zone, we provided the minimal amount of information to convert a traditional DNS zone into a DNSSEC-enabled zone. This is what the zone looked like before we started:

```
$ dig @192.168.1.13 example.com. AXFR +multiline +onesoa
```

(continues on next page)

(continued from previous page)

```

; <<>> DiG 9.16.0 <<>> @192.168.1.13 example.com AXFR +multiline +onesoa
; (1 server found)
;; global options: +cmd
example.com.      600 IN SOA ns1.example.com. admin.example.com. (
                    2020040700 ; serial
                    1800      ; refresh (30 minutes)
                    900       ; retry (15 minutes)
                    2419200   ; expire (4 weeks)
                    300       ; minimum (5 minutes)
                    )
example.com.      600 IN NS ns1.example.com.
ftp.example.com.  600 IN A 192.168.1.200
ns1.example.com.  600 IN A 192.168.1.1
web.example.com.  600 IN CNAME www.example.com.
www.example.com.  600 IN A 192.168.1.100

```

Below shows the test zone `example.com` after reloading the server configuration. Clearly, the zone grew in size, and the number of records multiplied:

```

# dig @192.168.1.13 example.com. AXFR +multiline +onesoa

; <<>> DiG 9.16.0 <<>> @192.168.1.13 example.com AXFR +multiline +onesoa
; (1 server found)
;; global options: +cmd
example.com.      600 IN SOA ns1.example.com. admin.example.com. (
                    2020040703 ; serial
                    1800      ; refresh (30 minutes)
                    900       ; retry (15 minutes)
                    2419200   ; expire (4 weeks)
                    300       ; minimum (5 minutes)
                    )
example.com.      300 IN RRSIG NSEC 13 2 300 (
                    20200413050536 20200407140255 10376 example.com.
                    drtV1rJbo5OMi650Jtu7Jmg/thgpdTWrzr6O3Pzt12+B
                    oCxMAv3orWWYjfp2n9w5wj0rx2Mt2ev7MOOG8IOUCA== )
example.com.      300 IN NSEC ftp.example.com. NS SOA RRSIG NSEC DNSKEY TYPE65534
example.com.      600 IN RRSIG NS 13 2 600 (
                    20200413130638 20200407140255 10376 example.com.
                    Zipmzm1Ei6vfe90LowPMsxLBCbjrCpWPgWJ0ekwZBbux
                    MLffZOxn8clt0Ql2U9iCPdyoQryuJCiojHSE2d6nrw== )
example.com.      600 IN RRSIG SOA 13 2 600 (
                    20200421150255 20200407140255 10376 example.com.
                    jBsz92zwAcGMNV/yu167aKQZvFyC7BiQe1WEnlogdLTF
                    oq4yBQumOh05WX61LjA1711DuLWcd/ASwlUZWFGCYQ== )
example.com.      0 IN RRSIG TYPE65534 13 2 0 (
                    20200413050536 20200407140255 10376 example.com.
                    Xjkom24N6qeCJjg9BMUfuWf+euLeZB169DHvLYZPNlm
                    GgM2czUDPio6VpQbUw6JE5DSNjuGjgpgXC5SipC42g== )
example.com.      3600 IN RRSIG DNSKEY 13 2 3600 (
                    20200421150255 20200407140255 10376 example.com.
                    maK75+28oUyDtci3V7wjTsuhgkLUZW+Q++q46Lea6bKn
                    Xj77kXcLNogNdUOr5am/6O6cnPeJKJWsnmTLISm62g== )

```

(continues on next page)

(continued from previous page)

```

example.com.      0 IN TYPE65534 \# 5 ( 0D28880001 )
example.com.      3600 IN DNSKEY 257 3 13 (
6saiq99qDBb5b4G4cx13cPjFTrIvUs3NW44SvbbHorHb
kXwOzeGAWyPORN+pwEV/LP9+FHAF/JzAJYdqP+o0dw==
) ; KSK; alg = ECDSAP256SHA256 ; key id = 10376
example.com.      600 IN NS ns1.example.com.
ftp.example.com.  600 IN RRSIG A 13 3 600 (
20200413130638 20200407140255 10376 example.com.
UYo1njeUA49VhKnPSS3JO4G+/Xd2PD4m3Vaacnd191yz
BIOouEBAGPcrEM2BNrgR0op1EWSus9tG86SM1ZHGQu== )
ftp.example.com.  300 IN RRSIG NSEC 13 3 300 (
20200413130638 20200407140255 10376 example.com.
rPADrAMAPIPSF3S45OSY8kXBTYMS3nrZg4Awj7qRL+/b
sOKy6044MbIbjg+YWL69dBjKoTSeEGSCSt73uIxrYA== )
ftp.example.com.  300 IN NSEC ns1.example.com. A RRSIG NSEC
ftp.example.com.  600 IN A 192.168.1.200
ns1.example.com.  600 IN RRSIG A 13 3 600 (
20200413130638 20200407140255 10376 example.com.
YeoJg7qrJmxL6uLTnALwKU5byNldZ9Ggj5XjcbpPvujQ
ocG/ovGBg6pdugXC9UxE39bCD18dua1frjDcRCCZAA== )
ns1.example.com.  300 IN RRSIG NSEC 13 3 300 (
20200413130638 20200407140255 10376 example.com.
vukgQme6k7JwCf/mJOOzHXbE3fKtSro+Kc10T6dHMdsc
oM1/oXioZvgBZ9cKrQhIAUt7r1KUnrUwM6Je36wWFA== )
ns1.example.com.  300 IN NSEC web.example.com. A RRSIG NSEC
ns1.example.com.  600 IN A 192.168.1.1
web.example.com.  600 IN RRSIG CNAME 13 3 600 (
20200413130638 20200407140255 10376 example.com.
JXi4WYypofD5geUowVqlqJyHzvcRnsvU/ONhTBaUCw5Y
XtifKAXRHwrUL1HIwt37JYPLf5uYu90RfkWLj0GqTQ== )
web.example.com.  300 IN RRSIG NSEC 13 3 300 (
20200413130638 20200407140255 10376 example.com.
XF4Hsd58dalL+s6Qu99bG80PQyMf7ZrHEzDiEflRuykP
DfBRuf34z27vj70L01lp2Zix4BB1ahcEK2ae9ASAmA== )
web.example.com.  300 IN NSEC www.example.com. CNAME RRSIG NSEC
web.example.com.  600 IN CNAME www.example.com.
www.example.com.  600 IN RRSIG A 13 3 600 (
20200413050536 20200407140255 10376 example.com.
mACKXrDOF5JMWqncSiQ3pYWA6abyGDJ4wgGCumjLXhPy
0cMzJmKv2s7G6+tW3TsA6BK3UoMfv30oblY2Mnl4/A== )
www.example.com.  300 IN RRSIG NSEC 13 3 300 (
20200413050536 20200407140255 10376 example.com.
1YQ22odVt0TeP5gbNJwkvS684ipDmx6sEOsF0eCizhCv
x8osuOATdlPjIEztt+rveaErZ2nsoLor5k1nQAhsbQ== )
www.example.com.  300 IN NSEC example.com. A RRSIG NSEC
www.example.com.  600 IN A 192.168.1.100

```

But this is a really messy way to tell if the zone is set up properly with DNSSEC. Fortunately, there are tools to help us with that. Read on to *How To Test Authoritative Zones* to learn more.

### 11.5.3 How To Test Authoritative Zones

So we've activated DNSSEC and uploaded some data to our parent zone. How do we know our zone is signed correctly? Here are a few ways to check.

#### Look for Key Data in Your Zone

One way to see if your zone is signed is to check for the presence of DNSKEY record types. In our example, we created a single key, and we expect to see it returned when we query for it.

```
$ dig @192.168.1.13 example.com. DNSKEY +multiline

; <<>> DiG 9.16.0 <<>> @10.53.0.6 example.com DNSKEY +multiline
; (1 server found)
;; global options: +cmd
;; Got answer:
;; ->>HEADER<<- opcode: QUERY, status: NOERROR, id: 18637
;; flags: qr aa rd; QUERY: 1, ANSWER: 1, AUTHORITY: 0, ADDITIONAL: 1
;; WARNING: recursion requested but not available

;; OPT PSEUDOSECTION:
; EDNS: version: 0, flags:; udp: 4096
; COOKIE: efe186423313fb66010000005e8c997e99864f7d69ed7c11 (good)
;; QUESTION SECTION:
;example.com.          IN DNSKEY

;; ANSWER SECTION:
example.com.          3600 IN DNSKEY 257 3 13 (
                        6saiq99qDBb5b4G4cx13cPjFTrIvUs3NW44SvbbHorHb
                        kXwOzeGAWyPORN+pwEV/LP9+FHAf/JzAJYdqp+o0dw==
                        ) ; KSK; alg = ECDSAP256SHA256 ; key id = 10376
```

#### Look for Signatures in Your Zone

Another way to see if your zone data is signed is to check for the presence of a signature. With DNSSEC, every record<sup>5</sup> now comes with at least one corresponding signature, known as an RRSIG.

```
$ dig @192.168.1.13 example.com. SOA +dnssec +multiline

; <<>> DiG 9.16.0 <<>> @10.53.0.6 example.com SOA +dnssec +multiline
; (1 server found)
;; global options: +cmd
;; Got answer:
;; ->>HEADER<<- opcode: QUERY, status: NOERROR, id: 45219
;; flags: qr aa rd; QUERY: 1, ANSWER: 2, AUTHORITY: 0, ADDITIONAL: 1
;; WARNING: recursion requested but not available

;; OPT PSEUDOSECTION:
; EDNS: version: 0, flags: do; udp: 4096
; COOKIE: 75adff4f4ce916b2010000005e8c99c0de47eabb7951b2f5 (good)
;; QUESTION SECTION:
;example.com.          IN SOA
```

(continues on next page)

<sup>5</sup> Well, almost every record: NS records and glue records for delegations do not have RRSIG records. If there are no delegations, then every record in your zone is signed and comes with its own RRSIG.

(continued from previous page)

```
;; ANSWER SECTION:
example.com.      600 IN SOA ns1.example.com. admin.example.com. (
    2020040703 ; serial
    1800       ; refresh (30 minutes)
    900        ; retry (15 minutes)
    2419200    ; expire (4 weeks)
    300        ; minimum (5 minutes)
    )
example.com.      600 IN RRSIG SOA 13 2 600 (
    20200421150255 20200407140255 10376 example.com.
    jBsz92zwAcGMNV/yu167aKQZvFyC7BiQe1WEnlogdLTF
    oq4yBQumOh05WX61LjA17l1DuLWcd/ASwlUZWFGCYQ== )
```

The serial number was automatically incremented from the old, unsigned version. *named* keeps track of the serial number of the signed version of the zone independently of the unsigned version. If the unsigned zone is updated with a new serial number that is higher than the one in the signed copy, then the signed copy is increased to match it; otherwise, the two are kept separate.

### Examine the Zone File

Our original zone file `example.com.db` remains untouched, and *named* has generated three additional files automatically for us (shown below). The signed DNS data is stored in `example.com.db.signed` and in the associated journal file.

```
# cd /etc/bind
# ls
example.com.db  example.com.db.jbk  example.com.db.signed  example.com.db.signed.jnl
```

A quick description of each of the files:

- `.jbk`: a transient file used by *named*
- `.signed`: the signed version of the zone in raw format
- `.signed.jnl`: a journal file for the signed version of the zone

These files are stored in raw (binary) format for faster loading. To reveal the human-readable version, use *named-compilezone* as shown below. In the example below, we run the command on the raw format zone `example.com.db.signed` to produce a text version of the zone `example.com.text`:

```
# named-compilezone -f raw -F text -o example.com.text example.com example.com.db.
↳signed
zone example.com/IN: loaded serial 2014112008 (DNSSEC signed)
dump zone to example.com.text...done
OK
```

### Check the Parent

Although this is not strictly related to whether the zone is signed, a critical part of DNSSEC is the trust relationship between the parent and the child. Just because we, the child, have all the correctly signed records in our zone does not mean it can be fully validated by a validating resolver, unless our parent's data agrees with ours. To check if our upload to the parent was successful, ask the parent name server for the DS record of our child zone; we should get back the DS record(s) containing the information we uploaded in *Uploading Information to the Parent Zone*:

```
$ dig example.com. DS

; <<>> DiG 9.16.0 <<>> example.com DS
; (1 server found)
;; global options: +cmd
;; Got answer:
;; ->>HEADER<<- opcode: QUERY, status: NOERROR, id: 16954
;; flags: qr rd ra ad; QUERY: 1, ANSWER: 1, AUTHORITY: 0, ADDITIONAL: 1

;; OPT PSEUDOSECTION:
; EDNS: version: 0, flags:; udp: 4096
; COOKIE: db280d5b52576780010000005e8c9bf5b0d8de103d934e5d (good)
;; QUESTION SECTION:
;example.com.                IN      DS

;; ANSWER SECTION:
example.com. 61179 IN DS 10376 13 2
↳B92E22CAE0B41430EC38D3F7EDF1183C3A94F4D4748569250C15EE33B8312EF0
```

## External Testing Tools

We recommend two tools, below: Verisign DNSSEC Debugger and DNSViz. Others can be found via a simple online search. These excellent online tools are an easy way to verify that your domain name is fully secured.

### Verisign DNSSEC Debugger

URL: <https://dnssec-debugger.verisignlabs.com/>

This tool shows a nice summary of checks performed on your domain name. You can expand it to view more details for each of the items checked, to get a detailed report.

### DNSViz

URL: <https://dnsviz.net/>

DNSViz provides a visual analysis of the DNSSEC authentication chain for a domain name and its resolution path in the DNS namespace.

## 11.5.4 Signing Easy Start Explained

### Enable Automatic DNSSEC Maintenance Explained

Signing a zone requires a number of separate steps:

- Generation of the keys to sign the zone.
- Inclusion of the keys into the zone.
- Signing of the records in the file (including the generation of the NSEC or NSEC3 records).

Maintaining a signed zone comprises a set of ongoing tasks:

- Re-signing the zone as signatures approach expiration.
- Generation of new keys as the time approaches for a key roll.
- Inclusion of new keys into the zone when the rollover starts.

	<ul style="list-style-type: none"> <li>✔ Found 3 DNSKEY records for .</li> <li>✔ DS=20326/SHA-256 verifies DNSKEY=20326/SEP</li> <li>✔ Found 1 RRSIGs over DNSKEY RRset</li> <li>✔ RRSIG=20326 and DNSKEY=20326/SEP verifies the DNSKEY RRset</li> </ul>
org	<ul style="list-style-type: none"> <li>✔ Found 2 DS records for org in the . zone</li> <li>✔ DS=9795/SHA-1 has algorithm RSASHA1-NSEC3-SHA1</li> <li>✔ DS=9795/SHA-256 has algorithm RSASHA1-NSEC3-SHA1</li> <li>✔ Found 1 RRSIGs over DS RRset</li> <li>✔ RRSIG=48903 and DNSKEY=48903 verifies the DS RRset</li> <li>✔ Found 4 DNSKEY records for org</li> <li>✔ DS=9795/SHA-1 verifies DNSKEY=9795/SEP</li> <li>✔ Found 3 RRSIGs over DNSKEY RRset</li> <li>✔ RRSIG=9795 and DNSKEY=9795/SEP verifies the DNSKEY RRset</li> </ul>
isc.org	<ul style="list-style-type: none"> <li>✔ Found 1 DS records for isc.org in the org zone</li> <li>✔ DS=7250/SHA-256 has algorithm ECDSAP256SHA256</li> <li>✔ Found 1 RRSIGs over DS RRset</li> <li>✔ RRSIG=37022 and DNSKEY=37022 verifies the DS RRset</li> <li>✔ Found 2 DNSKEY records for isc.org</li> <li>✔ DS=7250/SHA-256 verifies DNSKEY=7250/SEP</li> <li>✔ Found 2 RRSIGs over DNSKEY RRset</li> <li>✔ RRSIG=7250 and DNSKEY=7250/SEP verifies the DNSKEY RRset</li> <li>✔ isc.org A RR has value 149.20.1.66</li> <li>✔ Found 1 RRSIGs over A RRset</li> <li>✔ RRSIG=27566 and DNSKEY=27566 verifies the A RRset</li> </ul>

Fig. 3: Verisign DNSSEC Debugger

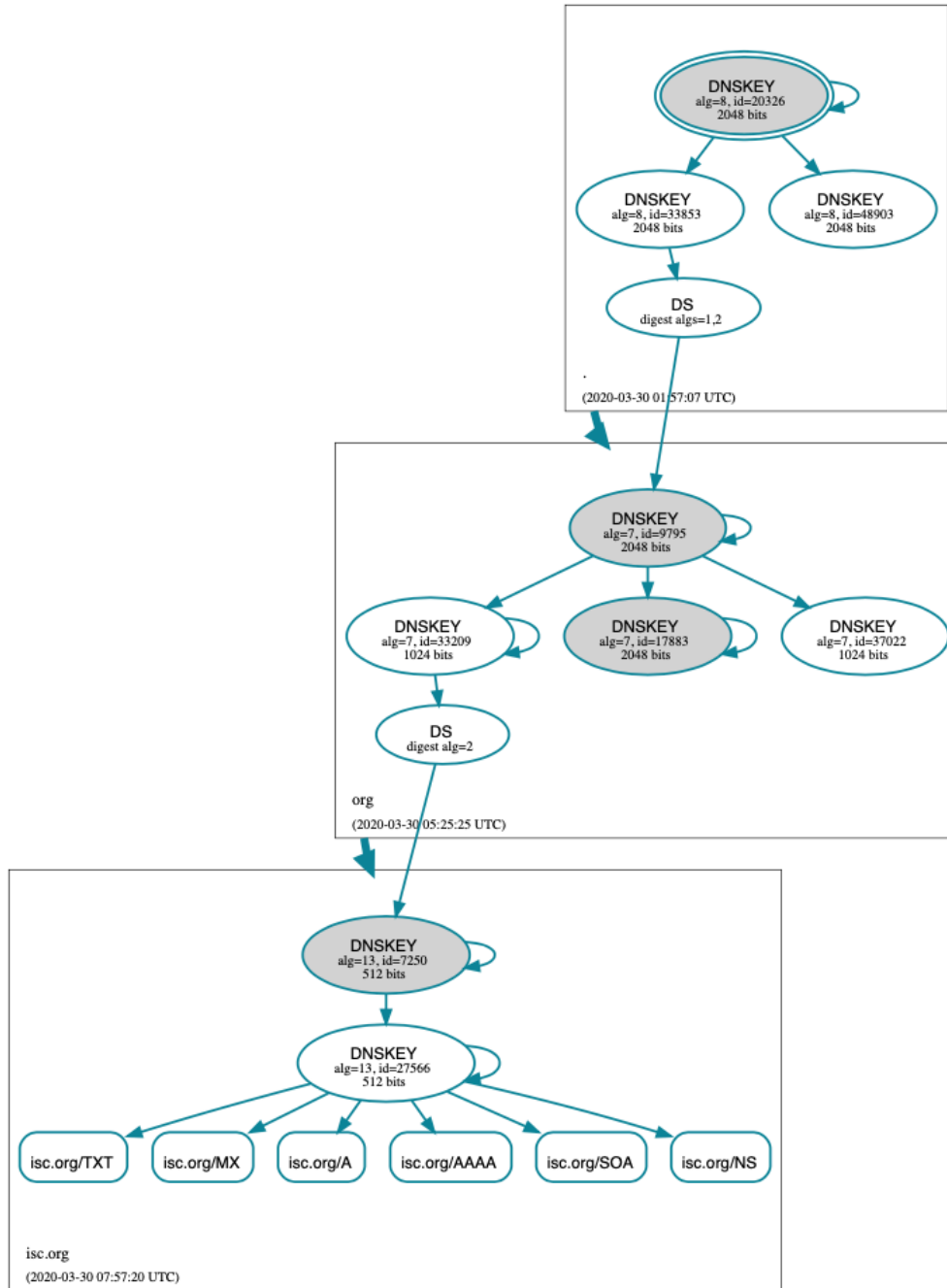

Fig. 4: DNSViz

- Transition from signing the zone with the old set of keys to signing the zone with the new set of keys.
- Waiting the appropriate interval before removing the old keys from the zone.
- Deleting the old keys.

That is quite complex, and it is all handled in BIND 9 with the single `dnssec-policy default` statement. We will see later on (in the *Creating a Custom DNSSEC Policy* section) how these actions can be tuned, by setting up our own DNSSEC policy with customized parameters. However, in many cases the defaults are adequate.

At the time of this writing (mid-2020), `dnssec-policy` is still a relatively new feature in BIND. Although it is the preferred way to run DNSSEC in a zone, it is not yet able to automatically implement all the features that are available with a more "hands-on" approach to signing and key maintenance. For this reason, we cover alternative signing techniques in *Alternate Ways of Signing a Zone*.

### 11.5.5 Working With the Parent Zone

As mentioned in *Uploading Information to the Parent Zone*, the format of the information uploaded to your parent zone is dictated by your parent zone administrator. The two main formats are:

1. DS record format
2. DNSKEY format

Check with your parent zone to see which format they require.

But how can you get each of the formats from your existing data?

When `named` turned on automatic DNSSEC maintenance, essentially the first thing it did was to create the DNSSEC keys and put them in the directory you specified in the configuration file. If you look in that directory, you will see three files with names like `Kexample.com.+013+10376.key`, `Kexample.com.+013+10376.private`, and `Kexample.com.+013+10376.state`. The one we are interested in is the one with the `.key` suffix, which contains the zone's public key. (The other files contain the zone's private key and the DNSSEC state associated with the key.) This public key is used to generate the information we need to pass to the parent.

#### DS Record Format

Below is an example of a DS record format generated from the KSK we created earlier (`Kexample.com.+013+10376.key`):

```
# cd /etc/bind
dnssec-dsfromkey Kexample.com.+013+10376.key
example.com. IN DS 10376 13 2
↳B92E22CAE0B41430EC38D3F7EDF1183C3A94F4D4748569250C15EE33B8312EF0
```

Some registrars ask their customers to manually specify the types of algorithm and digest used. In this example, 13 represents the algorithm used, and 2 represents the digest type (SHA-256). The key tag or key ID is 10376.

#### DNSKEY Format

Below is an example of the same key ID (10376) using DNSKEY format (with the actual key shortened for ease of display):

```
example.com. 3600 IN DNSKEY 257 3 13 (6saiq99qDB...dqp+o0dw==) ; key id = 10376
```

The key itself is easy to find (it's difficult to miss that long base64 string) in the file.

```
# cd /etc/bind
# cat Kexample.com.+013+10376.key
; This is a key-signing key, keyid 10376, for example.com.
; Created: 20200407150255 (Tue Apr  7 16:02:55 2020)
; Publish: 20200407150255 (Tue Apr  7 16:02:55 2020)
; Activate: 20200407150255 (Tue Apr  7 16:02:55 2020)
example.com. 3600 IN DNSKEY 257 3 13 6saiq99qDB...dqp+o0dw==
```

### 11.5.6 Creating a Custom DNSSEC Policy

The remainder of this section describes the contents of a custom DNSSEC policy. *Advanced Discussions* describes the concepts involved here and the pros and cons of choosing particular values. If you are not already familiar with DNSSEC, it may be worth reading that chapter first.

Setting up your own DNSSEC policy means that you must include a *dnssec-policy* clause in the zone file. This sets values for the various parameters that affect the signing of zones and the rolling of keys. The following is an example of such a clause:

```
dnssec-policy standard {
    dnskey-ttl 600;
    keys {
        ksk lifetime 365d algorithm ecdsap256sha256;
        zsk lifetime 60d algorithm ecdsap256sha256;
    };
    max-zone-ttl 600;
    parent-ds-ttl 600;
    parent-propagation-delay 2h;
    publish-safety 7d;
    retire-safety 7d;
    signatures-refresh 5d;
    signatures-validity 15d;
    signatures-validity-dnskey 15d;
    zone-propagation-delay 2h;
};
```

The policy has multiple parts:

- The name must be specified. As each zone can use a different policy, *named* needs to be able to distinguish between policies. This is done by giving each policy a name, such as `standard` in the above example.
- The *keys* clause lists all keys that should be in the zone, along with their associated parameters. In this example, we are using the conventional KSK/ZSK split, with the KSK changed every year and the ZSK changed every two months (the default DNSSEC policy sets a CSK that is never changed). Keys are created using the ECDSAPS256SHA256 algorithm; each KSK/ZSK pair must have the same algorithm. A CSK combines the functionality of a ZSK and a KSK.
- The parameters ending in `-ttl` are, as expected, the TTLs of the associated records. Remember that during a key rollover, we have to wait for records to expire from caches? The values here tell BIND 9 the maximum amount of time it has to wait for this to happen. Values can be set for the DNSKEY records in your zone, the non-DNSKEY records in your zone, and the DS records in the parent zone.
- Another set of time-related parameters are those ending in `-propagation-delay`. These tell BIND how long it takes for a change in zone contents to become available on all secondary servers. (This may be non-negligible: for example, if a large zone is transferred over a slow link.)

- The policy also sets values for the various signature parameters: how long the signatures on the DNSKEY and non-DNSKEY records are valid, and how often BIND should re-sign the zone.
- The parameters ending in `-safety` are there to give you a bit of leeway in case a key roll doesn't go to plan. When introduced into the zone, the `publish-safety` time is the amount of additional time, over and above that calculated from the other parameters, during which the new key is in the zone but before BIND starts to sign records with it. Similarly, the `retire-safety` is the amount of additional time, over and above that calculated from the other parameters, during which the old key is retained in the zone before being removed.
- Finally, the `purge-keys` option allows you to clean up key files automatically after a period of time. If a key has been removed from the zone, this option will determine how long its key files will be retained on disk.

(You do not have to specify all the items listed above in your policy definition. Any that are not set simply take the default value.)

Usually, the exact timing of a key roll, or how long a signature remains valid, is not critical. For this reason, err on the side of caution when setting values for the parameters. It is better to have an operation like a key roll take a few days longer than absolutely required, than it is to have a quick key roll but have users get validation failures during the process.

Having defined a new policy called "standard", we now need to tell `named` to use it. We do this by adding a `dnssec-policy standard;` statement to the configuration file. Like many other configuration statements, it can be placed in the `options` statement (thus applying to all zones on the server), a `view` statement (applying to all zones in the view), or a `zone` statement (applying only to that zone). In this example, we'll add it to the `zone` statement:

```
zone "example.net" in {
    ...
    dnssec-policy standard;
    inline-signing yes;
    ...
};
```

Finally, tell `named` to use the new policy:

```
# rndc reconfig
```

... and that's it. `named` now applies the "standard" policy to your zone.

## 11.5.7 Maintenance Tasks

Zone data is signed and the parent zone has published your DS records: at this point your zone is officially secure. When other validating resolvers look up information in your zone, they are able to follow the 12-step process as described in *How Does DNSSEC Change DNS Lookup (Revisited)?* and verify the authenticity and integrity of the answers.

There is not that much left for you, as the DNS administrator, to do on an ongoing basis. Whenever you update your zone, BIND automatically re-signs your zone with new RRSIG and NSEC/NSEC3 records, and even increments the serial number for you. If you choose to split your keys into a KSK and ZSK, the rolling of the ZSK is completely automatic. Rolling of a KSK or CSK may require some manual intervention, though, so let's examine two more DNSSEC-related resource records, CDS and CDNSKEY.

### The CDS and CDNSKEY Resource Records

Passing the DS record to the organization running the parent zone has always been recognized as a bottleneck in the key rollover process. To automate the process, the CDS and CDNSKEY resource records were introduced.

The CDS and CDNSKEY records are identical to the DS and DNSKEY records, except in the type code and the name. When such a record appears in the child zone, it is a signal to the parent that it should update the DS it has for that zone. In essence, when the parent notices the presence of the CDS and/or CDNSKEY record(s) in the child zone, it checks these records to verify that they are signed by a valid key for the zone. If the record(s) successfully validate, the parent

zone's DS RRset for the child zone is changed to correspond to the CDS (or CDNSKEY) records. (For more information on how the signaling works and the issues surrounding it, please refer to [RFC 7344](#) and [RFC 8078](#).)

### Working with the Parent Zone (2)

Once the zone is signed, the only required manual tasks are to monitor KSK or CSK key rolls and pass the new DS record to the parent zone. However, if the parent can process CDS or CDNSKEY records, you may not even have to do that.<sup>6</sup>

When the time approaches for the roll of a KSK or CSK, BIND adds a CDS and a CDNSKEY record for the key in question to the apex of the zone. If your parent zone supports polling for CDS/CDNSKEY records, they are uploaded and the DS record published in the parent - at least ideally.

If BIND is configured with *parental-agents*, it will check for the DS presence. Let's look at the following configuration excerpt:

```
parental-agents "net" {
    10.53.0.11; 10.53.0.12;
};

zone "example.net" in {
    ...
    dnssec-policy standard;
    inline-signing yes;
    parental-agents { "net"; };
    ...
};
```

BIND will check for the presence of the DS record in the parent zone by querying its parental agents (defined in [RFC 7344](#) to be the entities that the child zone has a relationship with to change its delegation information). In the example above, The zone *example.net* is configured with two parental agents, at the addresses 10.53.0.11 and 10.53.0.12. These addresses are used as an example only. Both addresses will have to respond with a DS RRset that includes the DS record identifying the key that is being rolled. If one or both don't have the DS included yet the rollover is paused, and the check for DS presence is retried after an hour. The same applies for DS withdrawal.

Alternatively, you can use the *rndc* tool to tell *named* that the DS record has been published or withdrawn. For example:

```
# rndc dnssec -checkds published example.net
```

If your parent zone doesn't support CDS/CDNSKEY, you will have to supply the DNSKEY or DS record to the parent zone manually when a new KSK appears in your zone, presumably using the same mechanism you used to upload the records for the first time. Again, you need to use the *rndc* tool to tell *named* that the DS record has been published.

## 11.5.8 Alternate Ways of Signing a Zone

Although use of the automatic *dnssec-policy* is the preferred way to sign zones in BIND, there are occasions where a more manual approach may be needed, such as when external hardware is used to generate and sign the zone. *dnssec-policy* does not currently support the use of external hardware, so if your security policy requires it, you need to use one of the methods described here.

The idea of DNSSEC was first discussed in the 1990s and has been extensively developed over the intervening years. BIND has tracked the development of this technology, often being the first name server implementation to introduce new features. However, for compatibility reasons, BIND retained older ways of doing things even when new ways were added. This particularly applies to signing and maintaining zones, where different levels of automation are available.

<sup>6</sup> For security reasons, a parent zone that supports CDS/CDNSKEY may require the DS record to be manually uploaded when we first sign the zone. Until our zone is signed, the parent cannot be sure that a CDS or CDNSKEY record it finds by querying our zone really comes from our zone; thus, it needs to use some other form of secure transfer to obtain the information.

The following is a list of the available methods of signing in BIND, in the order that they were introduced - and in order of decreasing complexity.

### Manual

"Manual" signing was the first method to be introduced into BIND and its name describes it perfectly: the user needs to do everything. In the more-automated methods, you load an unsigned zone file into *named*, which takes care of signing it. With manual signing, you have to provide a signed zone for *named* to serve.

In practice, this means creating an unsigned zone file as usual, then using the BIND-provided tools *dnssec-keygen* to create the keys and *dnssec-signzone* to sign the zone. The signed zone is stored in another file and is the one you tell BIND to load. To update the zone (for example, to add a resource record), you update the unsigned zone, re-sign it, and tell *named* to load the updated signed copy. The same goes for refreshing signatures or rolling keys; the user is responsible for providing the signed zone served by *named*. (In the case of rolling keys, you are also responsible for ensuring that the keys are added and removed at the correct times.)

Why would you want to sign your zone this way? You probably wouldn't in the normal course of events, but as there may be circumstances in which it is required, the scripts have been left in the BIND distribution.

### Semi-Automatic

The first step in DNSSEC automation came with BIND 9.7, when the *auto-dnssec* option was added. This causes *named* to periodically search the directory holding the key files (see *Generate Keys* for a description) and to use the information in them to both add and remove keys and sign the zone.

Use of *auto-dnssec* alone requires that the zone be dynamic, something not suitable for a number of situations, so BIND 9.9 added the *inline-signing* option. With this, *named* essentially keeps the signed and unsigned copies of the zone separate. The signed zone is created from the unsigned one using the key information; when the unsigned zone is updated and the zone reloaded, *named* detects the changes and updates the signed copy of the zone.

This mode of signing has been termed "semi-automatic" in this document because keys still have to be manually created (and deleted when appropriate). Although not an onerous task, it is still additional work.

Why would anyone want to use this method when fully automated ones are available? At the time of this writing (mid-2020), the fully automatic methods cannot handle all scenarios, particularly that of having a single key shared among multiple zones. They also do not handle keys stored in Hardware Security Modules (HSMs), which are briefly covered in *Hardware Security Modules (HSMs)*.

### Fully Automatic with *dnssec-keymgr*

The next step in the automation of DNSSEC operations came with BIND 9.11, which introduced the *dnssec-keymgr* utility. This is a separate program and was expected to be run on a regular basis (probably via *cron*). It read a DNSSEC policy from its configuration file and read timing information from the DNSSEC key files. With this information it created new key files with timing information in them consistent with the policy. *named* was run as usual, picking up the timing information in the key files to determine when to add and remove keys, and when to sign with them.

In BIND 9.17.0 and later, this method of handling DNSSEC policies has been replaced by the *dnssec-policy* statement in the configuration file.

### Fully Automatic with *dnssec-policy*

Introduced a BIND 9.16, *dnssec-policy* replaces *dnssec-keymgr* from BIND 9.17 onwards and avoids the need to run a separate program. It also handles the creation of keys if a zone is added (*dnssec-keymgr* requires an initial key) and deletes old key files as they are removed from the zone. This is the method described in *Easy-Start Guide for Signing Authoritative Zones*.

We now look at some of these methods in more detail. We cover semi-automatic signing first, as that contains a lot of useful information about keys and key timings. After that, we touch on fully automatic signing with *dnssec-policy*. Since this has already been described in *Easy-Start Guide for Signing Authoritative Zones*, we will just mention a few additional points. Finally, we briefly describe manual signing.

## Semi-Automatic Signing

As noted above, the term semi-automatic signing has been used in this document to indicate the mode of signing enabled by the `auto-dnssec` and `inline-signing` keywords. `named` signs the zone without any manual intervention, based purely on the timing information in the DNSSEC key files. The files, however, must be created manually.

By appropriately setting the key parameters and the timing information in the key files, you can implement any DNSSEC policy you want for your zones. But why manipulate the key information yourself rather than rely on `dnssec-policy` to do it for you? The answer is that semi-automatic signing allows you to do things that, at the time of this writing (mid-2020), are currently not possible with one of the key managers: for example, the ability to use an HSM to store keys, or the ability to use the same key for multiple zones.

To convert a traditional (insecure) DNS zone to a secure one, we need to create various additional records (DNSKEY, RRSIG, NSEC/NSEC3) and, as with fully automatic signing, to upload verifiable information (such as a DS record) to the parent zone to complete the chain of trust.

### Note

Again, we assume all configuration files, key files, and zone files are stored in `/etc/bind`, and most examples show commands run as the root user. This may not be ideal, but the point is not to distract from what is important here: learning how to sign a zone. There are many best practices for deploying a more secure BIND installation, with techniques such as jailed process and restricted user privileges, but those are not covered in this document. We trust you, a responsible DNS administrator, to take the necessary precautions to secure your system.

For our examples below, we work with the assumption that there is an existing insecure zone `example.com` that we are converting to a secure version. The secure version uses both a KSK and a ZSK.

## Generate Keys

Everything in DNSSEC centers around keys, so we begin by generating our own keys.

```
# cd /etc/bind/keys
# dnssec-keygen -a ECDSAP256SHA256 example.com
Generating key pair.....+++++ .....+++++
Kexample.com.+013+34371
# dnssec-keygen -a ECDSAP256SHA256 -f KSK example.com
Generating key pair.....+++ .....+++
Kexample.com.+013+00472
```

This command generates four key files in `/etc/bind/keys`:

- `Kexample.com.+013+34371.key`
- `Kexample.com.+013+34371.private`
- `Kexample.com.+013+00472.key`
- `Kexample.com.+013+00472.private`

The two files ending in `.key` are the public keys. These contain the DNSKEY resource records that appear in the zone. The two files ending in `.private` are the private keys, and contain the information that `named` actually uses to sign the zone.

Of the two pairs, one is the zone-signing key (ZSK), and one is the key-signing key (KSK).<sup>7</sup> We can tell which is which by looking at the file contents (the actual keys are shortened here for ease of display):

<sup>7</sup> Only one key file - for either a KSK or ZSK - is needed to signal the presence of the zone. `dnssec-keygen` creates files of both types as needed.

```
# cat Kexample.com.+013+34371.key
; This is a zone-signing key, keyid 34371, for example.com.
; Created: 20200616104249 (Tue Jun 16 11:42:49 2020)
; Publish: 20200616104249 (Tue Jun 16 11:42:49 2020)
; Activate: 20200616104249 (Tue Jun 16 11:42:49 2020)
example.com. IN DNSKEY 256 3 13 AwEAAfel66...LqkA7cvn8=
# cat Kexample.com.+013+00472.key
; This is a key-signing key, keyid 472, for example.com.
; Created: 20200616104254 (Tue Jun 16 11:42:54 2020)
; Publish: 20200616104254 (Tue Jun 16 11:42:54 2020)
; Activate: 20200616104254 (Tue Jun 16 11:42:54 2020)
example.com. IN DNSKEY 257 3 13 AwEAAbCR6U...l8xPjokVU=
```

The first line of each file tells us what type of key it is. Also, by looking at the actual DNSKEY record, we can tell them apart: 256 is ZSK, and 257 is KSK.

The name of the file also tells us something about the contents. See chapter *Zone keys* for more details.

Make sure that these files are readable by `named` and that the `.private` files are not readable by anyone else.

Alternatively, the `dnssec-keyfromlabel` program is used to get a key pair from a crypto hardware device and build the key files. Its usage is similar to `dnssec-keygen`.

### Setting Key Timing Information

You may remember that in the above description of this method, we said that time information related to rolling keys is stored in the key files. This is placed there by `dnssec-keygen` when the file is created, and it can be modified using `dnssec-settime`. By default, only a limited amount of timing information is included in the file, as illustrated in the examples in the previous section.

All the dates are the same, and are the date and time that `dnssec-keygen` created the key. We can use `dnssec-settime` to modify the dates. The dates can also be modified using an editor, but that is likely to be more error-prone than using `dnssec-settime`. For example, to publish this key in the zone on 1 July 2020, use it to sign records for a year starting on 15 July 2020, and remove it from the zone at the end of July 2021, we can use the following command:

```
# dnssec-settime -P 20200701 -A 20200715 -I 20210715 -D 20210731 Kexample.com.
↪+013+34371.key
./Kexample.com.+013+34371.key
./Kexample.com.+013+34371.private
```

which would set the contents of the key file to:

```
; This is a zone-signing key, keyid 34371, for example.com.
; Created: 20200616104249 (Tue Jun 16 11:42:49 2020)
; Publish: 20200701000000 (Wed Jul 1 01:00:00 2020)
; Activate: 20200715000000 (Wed Jul 15 01:00:00 2020)
; Inactive: 20210715000000 (Thu Jul 15 01:00:00 2021)
; Delete: 20210731000000 (Sat Jul 31 01:00:00 2021)
example.com. IN DNSKEY 256 3 13 AwEAAfel66...LqkA7cvn8=
```

(The actual key is truncated here to improve readability.)

Below is a complete list of each of the metadata fields, and how each one affects the signing of your zone:

1. *Created*: This records the date on which the key was created. It is not used in calculations; it is useful simply for documentation purposes.

2. *Publish*: This sets the date on which a key is to be published to the zone. After that date, the key is included in the zone but is not used to sign it. This allows validating resolvers to get a copy of the new key in their cache before there are any resource records signed with it. By default, if not specified at creation time, this is set to the current time, meaning the key is published as soon as *named* picks it up.
3. *Activate*: This sets the date on which the key is to be activated. After that date, resource records are signed with the key. By default, if not specified during creation time, this is set to the current time, meaning the key is used to sign data as soon as *named* picks it up.
4. *Revoke*: This sets the date on which the key is to be revoked. After that date, the key is flagged as revoked, although it is still included in the zone and used to sign it. This is used to notify validating resolvers that this key is about to be removed or retired from the zone. (This state is not used in normal day-to-day operations. See [RFC 5011](#) to understand the circumstances where it may be used.)
5. *Inactive*: This sets the date on which the key is to become inactive. After that date, the key is still included in the zone, but it is no longer used to sign it. This sets the "expiration" or "retire" date for a key.
6. *Delete*: This sets the date on which the key is to be deleted. After that date, the key is no longer included in the zone, but it continues to exist on the file system or key repository.

This can be summarized as follows:

Table 1: Key Metadata Comparison

Metadata	Included in Zone File?	Used to Sign Data?	Purpose
Created	No	No	Recording of key creation
Publish	Yes	No	Introduction of a key soon to be active
Activate	Yes	Yes	Activation date for new key
Revoke	Yes	Yes	Notification of a key soon to be retired
Inactive	Yes	No	Inactivation or retirement of a key
Delete	No	No	Deletion or removal of a key from a zone

The publication date is the date the key is introduced into the zone. Sometime later it is activated and is used to sign resource records. After a specified period, BIND stops using it to sign records, and at some other specified later time it is removed from the zone.

Finally, we should note that the *dnssec-keygen* command supports the same set of switches so we could have set the dates when we created the key.

## Reconfiguring BIND

Having created the keys with the appropriate timing information, the next step is to turn on DNSSEC signing. Below is a very simple *named.conf*; in our example environment, this file is */etc/bind/named.conf*.

```
options {
    directory "/etc/bind";
    recursion no;
    minimal-responses yes;
};

zone "example.com" IN {
    type primary;
    file "example.com.db";
    auto-dnssec maintain;
    inline-signing yes;
};
```

Once the configuration file is updated, tell *named* to reload:

```
# rndc reload
server reload successful
```

## Verifying That the Zone Is Signed Correctly

You should now check that the zone is signed. Follow the steps in *Verification*.

## Uploading the DS Record to the Parent

As described in *Uploading Information to the Parent Zone*, we must now upload the new information to the parent zone. The format of the information and how to generate it is described in *Working With the Parent Zone*, although it is important to remember that you must use the contents of the KSK file that you generated above as part of the process.

When the DS record is published in the parent zone, your zone is fully signed.

## Checking That Your Zone Can Be Validated

Finally, follow the steps in *How To Test Authoritative Zones* to confirm that a query recognizes the zone as properly signed and vouched for by the parent zone.

## So... What Now?

Once the zone is signed, it must be monitored as described in *Maintenance Tasks*. However, as the time approaches for a key roll, you must create the new key. Of course, it is possible to create keys for the next fifty years all at once and set the key times appropriately. Whether the increased risk in having the private key files for future keys available on disk offsets the overhead of having to remember to create a new key before a rollover depends on your organization's security policy.

## Fully Automatic Signing With *dnssec-policy*

Since BIND 9.16, key management is fully integrated into *named*. Managing the signing process and rolling of these keys has been described in *Easy-Start Guide for Signing Authoritative Zones* and is not repeated here. A few points are worth noting, though:

- The *dnssec-policy* statement in the *named* configuration file describes all aspects of the DNSSEC policy, including the signing.
- The *dnssec-policy* statement requires the zone to use dynamic DNS, or that *inline-signing* is enabled.

## Manual Signing

Manual signing of a zone was the first method of signing introduced into BIND and offers, as the name suggests, no automation. The user must handle everything: create the keys, sign the zone file with them, load the signed zone, periodically re-sign the zone, and manage key rolls, including interaction with the parent. A user certainly can do all this, but why not use one of the automated methods? Nevertheless, it may be useful for test purposes, so we cover it briefly here.

BIND 9 ships with several tools that are used in this process, which are explained in more detail below. In all cases, the *-h* option prints a full list of parameters. Note that the DNSSEC tools require the keyset files to be in the working directory or the directory specified by the *-d* option.

The first step is to create the keys as described in *Generate Keys*.

Then, edit the zone file to make sure the proper DNSKEY entries are included. The public keys should be inserted into the zone file by including the *.key* files using *\$INCLUDE* statements.

Finally, use the command `dnssec-signzone`. Any `keyset` files corresponding to secure sub-zones should be present. The zone signer generates NSEC, NSEC3, and RRSIG records for the zone, as well as DS for the child zones if `-g` is specified. If `-g` is not specified, then DS RRsets for the secure child zones need to be added manually.

By default, all zone keys which have an available private key are used to generate signatures. The following command signs the zone, assuming it is in a file called `zone.child.example`, using manually specified keys:

```
# cd /etc/bind/keys/example.com/
# dnssec-signzone -t -N INCREMENT -o example.com -f /etc/bind/db/example.com.signed.
↪db \
    /etc/bind/db/example.com.db Kexample.com.+013+17694.key Kexample.com.+013+06817.
↪key
Verifying the zone using the following algorithms: ECDSAP256SHA256.
Zone fully signed:
Algorithm: ECDSAP256SHA256: KSKs: 1 active, 0 stand-by, 0 revoked
                        ZSKs: 1 active, 0 stand-by, 0 revoked
/etc/bind/db/example.com.signed.db
Signatures generated:           17
Signatures retained:            0
Signatures dropped:              0
Signatures successfully verified: 0
Signatures unsuccessfully verified: 0
Signing time in seconds:         0.046
Signatures per second:          364.634
Runtime in seconds:              0.055
```

The `-o` switch explicitly defines the domain name (`example.com` in this case), while the `-f` switch specifies the output file name. The second line has three parameters: the unsigned zone name (`/etc/bind/db/example.com.db`), the ZSK file name, and the KSK file name. This also generates a plain-text file `/etc/bind/db/example.com.signed.db`, which can be manually verified for correctness.

`dnssec-signzone` also produces keyset and dsset files. These are used to provide the parent zone administrators with the DNSKEY records (or their corresponding DS records) that are the secure entry point to the zone.

Finally, `named.conf` needs to be updated to load the signed version of the zone, which looks something like this:

```
zone "example.com" IN {
    type primary;
    file "db/example.com.signed.db";
};
```

Once the `rndc reconfig` command is issued, BIND serves a signed zone. The file `dsset-example.com` (created by `dnssec-signzone` when it signed the `example.com` zone) contains the DS record for the zone's KSK. You will need to pass that to the administrator of the parent zone, to be placed in the zone.

Since this is a manual process, you will need to re-sign periodically, as well as every time the zone data changes. You will also need to manually roll the keys by adding and removing DNSKEY records (and interacting with the parent) at the appropriate times.

## 11.6 Basic DNSSEC Troubleshooting

In this chapter, we cover some basic troubleshooting techniques, some common DNSSEC symptoms, and their causes and solutions. This is not a comprehensive "how to troubleshoot any DNS or DNSSEC problem" guide, because that could easily be an entire book by itself.

## 11.6.1 Query Path

The first step in troubleshooting DNS or DNSSEC should be to determine the query path. Whenever you are working with a DNS-related issue, it is always a good idea to determine the exact query path to identify the origin of the problem.

End clients, such as laptop computers or mobile phones, are configured to talk to a recursive name server, and the recursive name server may in turn forward requests on to other recursive name servers before arriving at the authoritative name server. The giveaway is the presence of the Authoritative Answer (`aa`) flag in a query response: when present, we know we are talking to the authoritative server; when missing, we are talking to a recursive server. The example below shows an answer to a query for `www.example.com` without the Authoritative Answer flag:

```
$ dig @10.53.0.3 www.example.com A

; <<>> DiG 9.16.0 <<>> @10.53.0.3 www.example.com a
; (1 server found)
;; global options: +cmd
;; Got answer:
;; ->>HEADER<<- opcode: QUERY, status: NOERROR, id: 62714
;; flags: qr rd ra ad; QUERY: 1, ANSWER: 1, AUTHORITY: 0, ADDITIONAL: 1

;; OPT PSEUDOSECTION:
; EDNS: version: 0, flags:;; udp: 4096
; COOKIE: c823fe302625db5b010000005e722b504d81bb01c2227259 (good)
;; QUESTION SECTION:
;www.example.com.      IN  A

;; ANSWER SECTION:
www.example.com.      60  IN  A   10.1.0.1

;; Query time: 3 msec
;; SERVER: 10.53.0.3#53(10.53.0.3)
;; WHEN: Wed Mar 18 14:08:16 GMT 2020
;; MSG SIZE rcvd: 88
```

Not only do we not see the `aa` flag, we see an `ra` flag, which indicates Recursion Available. This indicates that the server we are talking to (10.53.0.3 in this example) is a recursive name server: although we were able to get an answer for `www.example.com`, we know that the answer came from somewhere else.

If we query the authoritative server directly, we get:

```
$ dig @10.53.0.2 www.example.com A

; <<>> DiG 9.16.0 <<>> @10.53.0.2 www.example.com a
; (1 server found)
;; global options: +cmd
;; Got answer:
;; ->>HEADER<<- opcode: QUERY, status: NOERROR, id: 39542
;; flags: qr aa rd; QUERY: 1, ANSWER: 1, AUTHORITY: 0, ADDITIONAL: 1
;; WARNING: recursion requested but not available
...
```

The `aa` flag tells us that we are now talking to the authoritative name server for `www.example.com`, and that this is not a cached answer it obtained from some other name server; it served this answer to us right from its own database. In fact, the Recursion Available (`ra`) flag is not present, which means this name server is not configured to perform recursion (at least not for this client), so it could not have queried another name server to get cached results.

## 11.6.2 Visible DNSSEC Validation Symptoms

After determining the query path, it is necessary to determine whether the problem is actually related to DNSSEC validation. You can use the `dig +cd` flag to disable validation, as described in *How Do I Know I Have a Validation Problem?*.

When there is indeed a DNSSEC validation problem, the visible symptoms, unfortunately, are very limited. With DNSSEC validation enabled, if a DNS response is not fully validated, it results in a generic SERVFAIL message, as shown below when querying against a recursive name server at 192.168.1.7:

```
$ dig @10.53.0.3 www.example.org. A

; <<>> DiG 9.16.0 <<>> @10.53.0.3 www.example.org A
; (1 server found)
;; global options: +cmd
;; Got answer:
;; ->>HEADER<<- opcode: QUERY, status: SERVFAIL, id: 28947
;; flags: qr rd ra; QUERY: 1, ANSWER: 0, AUTHORITY: 0, ADDITIONAL: 1

;; OPT PSEUDOSECTION:
; EDNS: version: 0, flags:;; udp: 4096
; COOKIE: d1301968aca086ad010000005e723a7113603c01916d136b (good)
;; QUESTION SECTION:
;www.example.org.      IN  A

;; Query time: 3 msec
;; SERVER: 10.53.0.3#53(10.53.0.3)
;; WHEN: Wed Mar 18 15:12:49 GMT 2020
;; MSG SIZE  rcvd: 72
```

With `delv`, a "resolution failed" message is output instead:

```
$ delv @10.53.0.3 www.example.org. A +rtrace
;; fetch: www.example.org/A
;; resolution failed: SERVFAIL
```

BIND 9 logging features may be useful when trying to identify DNSSEC errors.

## 11.6.3 Basic Logging

DNSSEC validation error messages show up in `syslog` as a query error by default. Here is an example of what it may look like:

```
validating www.example.org/A: no valid signature found
RRSIG failed to verify resolving 'www.example.org/A/IN': 10.53.0.2#53
```

Usually, this level of error logging is sufficient. Debug logging, described in *BIND DNSSEC Debug Logging*, gives information on how to get more details about why DNSSEC validation may have failed.

## 11.6.4 BIND DNSSEC Debug Logging

A word of caution: before you enable debug logging, be aware that this may dramatically increase the load on your name servers. Enabling debug logging is thus not recommended for production servers.

With that said, sometimes it may become necessary to temporarily enable BIND debug logging to see more details of how and whether DNSSEC is validating. DNSSEC-related messages are not recorded in `syslog` by default, even if query log is enabled; only DNSSEC errors show up in `syslog`.

The example below shows how to enable debug level 3 (to see full DNSSEC validation messages) in BIND 9 and have it sent to *syslog*:

```
logging {
  channel dnssec_log {
    syslog daemon;
    severity debug 3;
    print-category yes;
  };
  category dnssec { dnssec_log; };
};
```

The example below shows how to log DNSSEC messages to their own file (here, */var/log/dnssec.log*):

```
logging {
  channel dnssec_log {
    file "/var/log/dnssec.log";
    severity debug 3;
  };
  category dnssec { dnssec_log; };
};
```

After turning on debug logging and restarting BIND, a large number of log messages appear in *syslog*. The example below shows the log messages as a result of successfully looking up and validating the domain name *ftp.isc.org*.

```
validating ./NS: starting
validating ./NS: attempting positive response validation
  validating ./DNSKEY: starting
  validating ./DNSKEY: attempting positive response validation
  validating ./DNSKEY: verify rdataset (keyid=20326): success
  validating ./DNSKEY: marking as secure (DS)
validating ./NS: in validator_callback_dnskey
validating ./NS: keyset with trust secure
validating ./NS: resuming validate
validating ./NS: verify rdataset (keyid=33853): success
validating ./NS: marking as secure, noqname proof not needed
validating ftp.isc.org/A: starting
validating ftp.isc.org/A: attempting positive response validation
validating isc.org/DNSKEY: starting
validating isc.org/DNSKEY: attempting positive response validation
  validating isc.org/DS: starting
  validating isc.org/DS: attempting positive response validation
validating org/DNSKEY: starting
validating org/DNSKEY: attempting positive response validation
  validating org/DS: starting
  validating org/DS: attempting positive response validation
  validating org/DS: keyset with trust secure
  validating org/DS: verify rdataset (keyid=33853): success
  validating org/DS: marking as secure, noqname proof not needed
validating org/DNSKEY: in validator_callback_ds
validating org/DNSKEY: dsset with trust secure
validating org/DNSKEY: verify rdataset (keyid=9795): success
validating org/DNSKEY: marking as secure (DS)
  validating isc.org/DS: in fetch_callback_dnskey
```

(continues on next page)

(continued from previous page)

```

validating isc.org/DS: keyset with trust secure
validating isc.org/DS: resuming validate
validating isc.org/DS: verify rdataset (keyid=33209): success
validating isc.org/DS: marking as secure, noqname proof not needed
validating isc.org/DNSKEY: in validator_callback_ds
validating isc.org/DNSKEY: dsset with trust secure
validating isc.org/DNSKEY: verify rdataset (keyid=7250): success
validating isc.org/DNSKEY: marking as secure (DS)
validating ftp.isc.org/A: in fetch_callback_dnskey
validating ftp.isc.org/A: keyset with trust secure
validating ftp.isc.org/A: resuming validate
validating ftp.isc.org/A: verify rdataset (keyid=27566): success
validating ftp.isc.org/A: marking as secure, noqname proof not needed

```

Note that these log messages indicate that the chain of trust has been established and `ftp.isc.org` has been successfully validated.

If validation had failed, you would see log messages indicating errors. We cover some of the most validation problems in the next section.

## 11.6.5 Common Problems

### Security Lameness

Similar to lame delegation in traditional DNS, security lameness refers to the condition when the parent zone holds a set of DS records that point to something that does not exist in the child zone. As a result, the entire child zone may "disappear," having been marked as bogus by validating resolvers.

Below is an example attempting to resolve the A record for a test domain name `www.example.net`. From the user's perspective, as described in *How Do I Know I Have a Validation Problem?*, only a SERVFAIL message is returned. On the validating resolver, we see the following messages in `syslog`:

```

named[126063]: validating example.net/DNSKEY: no valid signature found (DS)
named[126063]: no valid RRSIG resolving 'example.net/DNSKEY/IN': 10.53.0.2#53
named[126063]: broken trust chain resolving 'www.example.net/A/IN': 10.53.0.2#53

```

This gives us a hint that it is a broken trust chain issue. Let's take a look at the DS records that are published for the zone (with the keys shortened for ease of display):

```

$ dig @10.53.0.3 example.net. DS

; <<>> DiG 9.16.0 <<>> @10.53.0.3 example.net DS
; (1 server found)
;; global options: +cmd
;; Got answer:
;; ->>HEADER<<- opcode: QUERY, status: NOERROR, id: 59602
;; flags: qr rd ra ad; QUERY: 1, ANSWER: 1, AUTHORITY: 0, ADDITIONAL: 1

;; OPT PSEUDOSECTION:
; EDNS: version: 0, flags:; udp: 4096
; COOKIE: 7026d8f7c6e77e2a010000005e735d7c9d038d061b2d24da (good)
;; QUESTION SECTION:
;example.net.          IN      DS

```

(continues on next page)

(continued from previous page)

```
;; ANSWER SECTION:
example.net.      256 IN  DS   14956 8 2 9F3CACD...D3E3A396

;; Query time: 0 msec
;; SERVER: 10.53.0.3#53(10.53.0.3)
;; WHEN: Thu Mar 19 11:54:36 GMT 2020
;; MSG SIZE rcvd: 116
```

Next, we query for the DNSKEY and RRSIG of `example.net` to see if there's anything wrong. Since we are having trouble validating, we can use the `dig +cd` option to temporarily disable checking and return results, even though they do not pass the validation tests. The `dig +multiline` option causes `dig` to print the type, algorithm type, and key id for DNSKEY records. Again, some long strings are shortened for ease of display:

```
$ dig @10.53.0.3 example.net. DNSKEY +dnssec +cd +multiline

; <<>> DiG 9.16.0 <<>> @10.53.0.3 example.net DNSKEY +cd +multiline +dnssec
; (1 server found)
;; global options: +cmd
;; Got answer:
;; ->>HEADER<<- opcode: QUERY, status: NOERROR, id: 42980
;; flags: qr rd ra cd; QUERY: 1, ANSWER: 4, AUTHORITY: 0, ADDITIONAL: 1

;; OPT PSEUDOSECTION:
; EDNS: version: 0, flags: do; udp: 4096
; COOKIE: 4b5e7c88b3680c35010000005e73722057551f9f8be1990e (good)
;; QUESTION SECTION:
;example.net.      IN  DNSKEY

;; ANSWER SECTION:
example.net.      287 IN  DNSKEY 256 3 8 (
                AwEAAbu3NX...ADU/D7xjFFDu+8WRIn
                ) ; ZSK; alg = RSASHA256 ; key id = 35328
example.net.      287 IN  DNSKEY 257 3 8 (
                AwEAAbKtU1...PPP4aQZTybk75ZW+uL
                6OJMAF63NO0s1nAZM2EWAVasbnn/X+J4N2rLuhk=
                ) ; KSK; alg = RSASHA256 ; key id = 27247
example.net.      287 IN  RRSIG DNSKEY 8 2 300 (
                20811123173143 20180101000000 27247 example.net.
                Fz1sjClIoF...YEjzpAWuAj9peQ== )
example.net.      287 IN  RRSIG DNSKEY 8 2 300 (
                20811123173143 20180101000000 35328 example.net.
                seKtUeJ4/l...YtDc1rcXTVlWIOw= )

;; Query time: 0 msec
;; SERVER: 10.53.0.3#53(10.53.0.3)
;; WHEN: Thu Mar 19 13:22:40 GMT 2020
;; MSG SIZE rcvd: 962
```

Here is the problem: the parent zone is telling the world that `example.net` is using the key 14956, but the authoritative server indicates that it is using keys 27247 and 35328. There are several potential causes for this mismatch: one possibility is that a malicious attacker has compromised one side and changed the data. A more likely scenario is that the DNS administrator for the child zone did not upload the correct key information to the parent zone.

### Incorrect Time

In DNSSEC, every record comes with at least one RRSIG, and each RRSIG contains two timestamps: one indicating when it becomes valid, and one when it expires. If the validating resolver's current system time does not fall within the two RRSIG timestamps, error messages appear in the BIND debug log.

The example below shows a log message when the RRSIG appears to have expired. This could mean the validating resolver system time is incorrectly set too far in the future, or the zone administrator has not kept up with RRSIG maintenance.

```
validating example.com/DNSKEY: verify failed due to bad signature (keyid=19036):_
↳RRSIG has expired
```

The log below shows that the RRSIG validity period has not yet begun. This could mean the validation resolver's system time is incorrectly set too far in the past, or the zone administrator has incorrectly generated signatures for this domain name.

```
validating example.com/DNSKEY: verify failed due to bad signature (keyid=4521): RRSIG_
↳validity period has not begun
```

### Unable to Load Keys

This is a simple yet common issue. If the key files are present but unreadable by *named* for some reason, the *syslog* returns clear error messages, as shown below:

```
named[32447]: zone example.com/IN (signed): reconfiguring zone keys
named[32447]: dns_dnssec_findmatchingkeys: error reading key file Kexample.com.
↳+008+06817.private: permission denied
named[32447]: dns_dnssec_findmatchingkeys: error reading key file Kexample.com.
↳+008+17694.private: permission denied
named[32447]: zone example.com/IN (signed): next key event: 27-Nov-2014 20:04:36.521
```

However, if no keys are found, the error is not as obvious. Below shows the *syslog* messages after executing *rndc reload* with the key files missing from the key directory:

```
named[32516]: received control channel command 'reload'
named[32516]: loading configuration from '/etc/bind/named.conf'
named[32516]: reading built-in trusted keys from file '/etc/bind/bind.keys'
named[32516]: using default UDP/IPv4 port range: [1024, 65535]
named[32516]: using default UDP/IPv6 port range: [1024, 65535]
named[32516]: sizing zone task pool based on 6 zones
named[32516]: the working directory is not writable
named[32516]: reloading configuration succeeded
named[32516]: reloading zones succeeded
named[32516]: all zones loaded
named[32516]: running
named[32516]: zone example.com/IN (signed): reconfiguring zone keys
named[32516]: zone example.com/IN (signed): next key event: 27-Nov-2014 20:07:09.292
```

This happens to look exactly the same as if the keys were present and readable, and appears to indicate that *named* loaded the keys and signed the zone. It even generates the internal (raw) files:

```
# cd /etc/bind/db
# ls
example.com.db example.com.db.jbk example.com.db.signed
```

If *named* really loaded the keys and signed the zone, you should see the following files:

```
# cd /etc/bind/db
# ls
example.com.db  example.com.db.jbk  example.com.db.signed  example.com.db.signed.jnl
```

So, unless you see the `*.signed.jnl` file, your zone has not been signed.

### Invalid Trust Anchors

In most cases, you never need to explicitly configure trust anchors. `named` supplies the current root trust anchor and, with the default setting of `dnssec-validation`, updates it on the infrequent occasions when it is changed.

However, in some circumstances you may need to explicitly configure your own trust anchor. As we saw in the [Trust Anchors](#) section, whenever a DNSKEY is received by the validating resolver, it is compared to the list of keys the resolver explicitly trusts to see if further action is needed. If the two keys match, the validating resolver stops performing further verification and returns the answer(s) as validated.

But what if the key file on the validating resolver is misconfigured or missing? Below we show some examples of log messages when things are not working properly.

First of all, if the key you copied is malformed, BIND does not even start and you will likely find this error message in syslog:

```
named[18235]: /etc/bind/named.conf.options:29: bad base64 encoding
named[18235]: loading configuration: failure
```

If the key is a valid base64 string but the key algorithm is incorrect, or if the wrong key is installed, the first thing you will notice is that virtually all of your DNS lookups result in SERVFAIL, even when you are looking up domain names that have not been DNSSEC-enabled. Below shows an example of querying a recursive server 10.53.0.3:

```
$ dig @10.53.0.3 www.example.com. A

; <<>> DiG 9.16.0 <<>> @10.53.0.3 www.example.org A +dnssec
; (1 server found)
;; global options: +cmd
;; Got answer:
;; ->>HEADER<<- opcode: QUERY, status: SERVFAIL, id: 29586
;; flags: qr rd ra; QUERY: 1, ANSWER: 0, AUTHORITY: 0, ADDITIONAL: 1

;; OPT PSEUDOSECTION:
; EDNS: version: 0, flags: do; udp: 4096
; COOKIE: ee078fc321fa1367010000005e73a58bf5f205ca47e04bed (good)
;; QUESTION SECTION:
;www.example.org.      IN  A
```

`delv` shows a similar result:

```
$ delv @192.168.1.7 www.example.com. +rtrace
;; fetch: www.example.com/A
;; resolution failed: SERVFAIL
```

The next symptom you see is in the DNSSEC log messages:

```
managed-keys-zone: DNSKEY set for zone '.' could not be verified with current keys
validating ./DNSKEY: starting
validating ./DNSKEY: attempting positive response validation
```

(continues on next page)

(continued from previous page)

```
validating ./DNSKEY: no DNSKEY matching DS
validating ./DNSKEY: no DNSKEY matching DS
validating ./DNSKEY: no valid signature found (DS)
```

These errors are indications that there are problems with the trust anchor.

## 11.6.6 Negative Trust Anchors

BIND 9.11 introduced Negative Trust Anchors (NTAs) as a means to *temporarily* disable DNSSEC validation for a zone when you know that the zone's DNSSEC is misconfigured.

NTAs are added using the `rndc` command, e.g.:

```
$ rndc nta example.com
Negative trust anchor added: example.com/_default, expires 19-Mar-2020 19:57:42.000
```

The list of currently configured NTAs can also be examined using `rndc`, e.g.:

```
$ rndc nta -dump
example.com/_default: expiry 19-Mar-2020 19:57:42.000
```

The default lifetime of an NTA is one hour, although by default, BIND polls the zone every five minutes to see if the zone correctly validates, at which point the NTA automatically expires. Both the default lifetime and the polling interval may be configured via `named.conf`, and the lifetime can be overridden on a per-zone basis using the `-lifetime duration` parameter to `rndc nta`. Both timer values have a permitted maximum value of one week.

## 11.6.7 NSEC3 Troubleshooting

BIND includes a tool called `nsec3hash` that runs through the same steps as a validating resolver, to generate the correct hashed name based on NSEC3PARAM parameters. The command takes the following parameters in order: salt, algorithm, iterations, and domain. For example, if the salt is 1234567890ABCDEF, hash algorithm is 1, and iteration is 10, to get the NSEC3-hashed name for `www.example.com` we would execute a command like this:

```
$ nsec3hash 1234567890ABCDEF 1 10 www.example.com
RN7I9ME6E1I6BDKIP91B9TCE4FHJ7LKF (salt=1234567890ABCDEF, hash=1, iterations=10)
```

Zero-length salt can be specified as `-`.

While it is unlikely you would construct a rainbow table of your own zone data, this tool may be useful when troubleshooting NSEC3 problems.

## 11.7 Advanced Discussions

### 11.7.1 Signature Validity Periods and Zone Re-Signing Intervals

In *How Are Answers Verified?*, we saw that record signatures have a validity period outside of which they are not valid. This means that at some point, a signature will no longer be valid and a query for the associated record will fail DNSSEC validation. But how long should a signature be valid for?

The maximum value for the validity period should be determined by the impact of a replay attack: if this is low, the period can be long; if high, the period should be shorter. There is no "right" value, but periods of between a few days to a month are common.

Deciding a minimum value is probably an easier task. Should something fail (e.g., a hidden primary distributing to secondary servers that actually answer queries), how long will it take before the failure is noticed, and how long before it

is fixed? If you are a large 24x7 operation with operators always on-site, the answer might be less than an hour. In smaller companies, if the failure occurs just after everyone has gone home for a long weekend, the answer might be several days.

Again, there are no "right" values - they depend on your circumstances. The signature validity period you decide to use should be a value between the two bounds. At the time of this writing (mid-2020), the default policy used by BIND sets a value of 14 days.

To keep the zone valid, the signatures must be periodically refreshed since they expire - i.e., the zone must be periodically re-signed. The frequency of the re-signing depends on your network's individual needs. For example, signing puts a load on your server, so if the server is very highly loaded, a lower re-signing frequency is better. Another consideration is the signature lifetime: obviously the intervals between signings must not be longer than the signature validity period. But if you have set a signature lifetime close to the minimum (see above), the signing interval must be much shorter. What would happen if the system failed just before the zone was re-signed?

Again, there is no single "right" answer; it depends on your circumstances. The BIND 9 default policy sets the signature refresh interval to 5 days.

### 11.7.2 Proof of Non-Existence (NSEC and NSEC3)

How do you prove that something does not exist? This zen-like question is an interesting one, and in this section we provide an overview of how DNSSEC solves the problem.

Why is it even important to have authenticated denial of existence in DNS? Couldn't we just send back "hey, what you asked for does not exist," and somehow generate a digital signature to go with it, proving it really is from the correct authoritative source? Aside from the technical challenge of signing something that doesn't exist, this solution has flaws, one of which is it gives an attacker a way to create the appearance of denial of service by replaying this message on the network.

Let's use a little story, told three different ways, to illustrate how proof of nonexistence works. In our story, we run a small company with three employees: Alice, Edward, and Susan. For reasons that are far too complicated to go into, they don't have email accounts; instead, email for them is sent to a single account and a nameless intern passes the message to them. The intern has access to our private DNSSEC key to create signatures for their responses.

If we followed the approach of giving back the same answer no matter what was asked, when people emailed and asked for the message to be passed to "Bob," our intern would simply answer "Sorry, that person doesn't work here" and sign this message. This answer could be validated because our intern signed the response with our private DNSSEC key. However, since the signature doesn't change, an attacker could record this message. If the attacker were able to intercept our email, when the next person emailed asking for the message to be passed to Susan, the attacker could return the exact same message: "Sorry, that person doesn't work here," with the same signature. Now the attacker has successfully fooled the sender into thinking that Susan doesn't work at our company, and might even be able to convince all senders that no one works at this company.

To solve this problem, two different solutions were created. We will look at the first one, NSEC, next.

#### NSEC

The NSEC record is used to prove that something does not exist, by providing the name before it and the name after it. Using our tiny company example, this would be analogous to someone sending an email for Bob and our nameless intern responding with: "I'm sorry, that person doesn't work here. The name before the location where 'Bob' would be is Alice, and the name after that is Edward." Let's say another email was received for a non-existent person, this time Oliver; our intern would respond "I'm sorry, that person doesn't work here. The name before the location where 'Oliver' would be is Edward, and the name after that is Susan." If another sender asked for Todd, the answer would be: "I'm sorry, that person doesn't work here. The name before the location where 'Todd' would be is Susan, and there are no other names after that."

So we end up with four NSEC records:

```
example.com.      300 IN  NSEC  alice.example.com.  A RRSIG NSEC
alice.example.com. 300 IN  NSEC  edward.example.com. A RRSIG NSEC
edward.example.com. 300 IN  NSEC  susan.example.com.  A RRSIG NSEC
susan.example.com. 300 IN  NSEC  example.com.       A RRSIG NSEC
```

What if the attacker tried to use the same replay method described earlier? If someone sent an email for Edward, none of the four answers would fit. If attacker replied with message #2, "I'm sorry, that person doesn't work here. The name before it is Alice, and the name after it is Edward," it is obviously false, since "Edward" is in the response; and the same goes for #3, Edward and Susan. As for #1 and #4, Edward does not fall in the alphabetical range before Alice or after Susan, so the sender can logically deduce that it was an incorrect answer.

When BIND signs your zone, the zone data is automatically sorted on the fly before generating NSEC records, much like how a phone directory is sorted.

The NSEC record allows for a proof of non-existence for record types. If you ask a signed zone for a name that exists but for a record type that doesn't (for that name), the signed NSEC record returned lists all of the record types that *do* exist for the requested domain name.

NSEC records can also be used to show whether a record was generated as the result of a wildcard expansion. The details of this are not within the scope of this document, but are described well in [RFC 7129](#).

Unfortunately, the NSEC solution has a few drawbacks, one of which is trivial "zone walking." In our story, a curious person can keep sending emails, and our nameless, gullible intern keeps divulging information about our employees. Imagine if the sender first asked: "Is Bob there?" and received back the names Alice and Edward. Our sender could then email again: "Is Edwarda there?", and will get back Edward and Susan. (No, "Edwarda" is not a real name. However, it is the first name alphabetically after "Edward" and that is enough to get the intern to reply with a message telling us the next valid name after Edward.) Repeat the process enough times and the person sending the emails eventually learns every name in our company phone directory. For many of you, this may not be a problem, since the very idea of DNS is similar to a public phone book: if you don't want a name to be known publicly, don't put it in DNS! Consider using DNS views (split DNS) and only display your sensitive names to a select audience.

The second potential drawback of NSEC is a bigger zone file and memory consumption; there is no opt-out mechanism for insecure child zones, so each name in the zone will get an additional NSEC record and a RRSIG record to go with it. In practice this is a problem only for parent-zone operators dealing with mostly insecure child zones, such as `com.`. To learn more about opt-out, please see [NSEC3 Opt-Out](#).

### NSEC3

NSEC3 adds two additional features that NSEC does not have:

1. It offers no easy zone enumeration.
2. It provides a mechanism for the parent zone to exclude insecure delegations (i.e., delegations to zones that are not signed) from the proof of non-existence.

Recall that in [NSEC](#) we provided a range of names to prove that something does not exist. But as it turns out, even disclosing these ranges of names becomes a problem: this made it very easy for the curious-minded to look at our entire zone. Not only that, unlike a zone transfer, this "zone walking" is more resource-intensive. So how do we disclose something without actually disclosing it?

The answer is actually quite simple: hashing functions, or one-way hashes. Without going into many details, think of it like a magical meat grinder. A juicy piece of ribeye steak goes in one end, and out comes a predictable shape and size of ground meat (hash) with a somewhat unique pattern. No matter how hard you try, you cannot turn the ground meat back into the ribeye steak: that's what we call a one-way hash.

NSEC3 basically runs the names through a one-way hash before giving them out, so the recipients can verify the non-existence without any knowledge of the other names in the zone.

So let's tell our little story for the third time, this time with NSEC3. In this version, our intern is not given a list of actual names; he is given a list of "hashed" names. So instead of Alice, Edward, and Susan, the list he is given reads like this (hashes shortened for easier reading):

```
FSK5... (produced from Edward)
JKMA... (produced from Susan)
NTQ0... (produced from Alice)
```

Then, an email is received for Bob again. Our intern takes the name Bob through a hash function, and the result is L8J2..., so he replies: "I'm sorry, that person doesn't work here. The name before that is JKMA..., and the name after that is NTQ0...". There, we proved Bob doesn't exist, without giving away any names! To put that into proper NSEC3 resource records, they would look like this (again, hashes shortened for ease of display):

```
FSK5...example.com. 300 IN NSEC3 1 0 0 - JKMA... A RRSIG
JKMA...example.com. 300 IN NSEC3 1 0 0 - NTQ0... A RRSIG
NTQ0...example.com. 300 IN NSEC3 1 0 0 - FSK5... A RRSIG
```

**Note**

Just because we employed one-way hash functions does not mean there is no way for a determined individual to figure out our zone data.

Most names published in the DNS are rarely secret or unpredictable. They are published to be memorable, used and consumed by humans. They are often recorded in many other network logs such as email logs, certificate transparency logs, web page links, intrusion detection systems, malware scanners, email archives, etc. Many times a simple dictionary of commonly used domain-name prefixes (www, mail, imap, login, database, etc.) can be used to quickly reveal a large number of labels within a zone. Additionally, if an adversary really wants to expend significant CPU resources to mount an offline dictionary attack on a zone's NSEC3 chain, they will likely be able to find most of the "guessable" names despite any level of hashing.

Also, it is still possible to gather all of our NSEC3 records and hashed names and perform an offline brute-force attack by trying all possible combinations to figure out what the original name is. In our meat-grinder analogy, this would be like someone buying all available cuts of meat and grinding them up at home using the same model of meat grinder, and comparing the output with the meat you gave him. It is expensive and time-consuming (especially with real meat), but like everything else in cryptography, if someone has enough resources and time, nothing is truly private forever. If you are concerned about someone performing this type of attack on your zone data, use some of the special techniques described in [RFC 4470](#).

## NSEC3PARAM

**Warning**

Before we dive into the details of NSEC3 parametrization, please note: the defaults should not be changed without a strong justification and a full understanding of the potential impact. See [RFC 9276](#).

The above NSEC3 examples used four parameters: 1, 0, 0, and zero-length salt. 1 represents the algorithm, 0 represents the opt-out flag, 0 represents the number of additional iterations, and - is the salt. Let's look at how each one can be configured:

### Algorithm

#### NSEC3 Hashing Algorithm

The only currently defined value is 1 for SHA-1, so there is no configuration field for it.

**Opt-out**

Setting this bit to 1 enables NSEC3 opt-out, which is discussed in [NSEC3 Opt-Out](#).

**Iterations**

Iterations defines the number of `_additional_` times to apply the algorithm when generating an NSEC3 hash. More iterations consume more resources for both authoritative servers and validating resolvers. The considerations here are similar to those seen in [Key Sizes](#), of security versus resources.

**Warning**

Do not use values higher than zero. A value of zero provides one round of SHA-1 hashing and protects from non-determined attackers.

A greater number of additional iterations causes interoperability problems and opens servers to CPU-exhausting DoS attacks, while providing only doubtful security benefits.

**Salt**

A salt value, which can be combined with an FQDN to influence the resulting hash. Salt is discussed in more detail in [NSEC3 Salt](#).

**NSEC3 Opt-Out**

First things first: For most DNS administrators who do not manage a huge number of insecure delegations, the NSEC3 opt-out feature is not relevant. See [RFC 9276](#).

Opt-out allows for blocks of unsigned delegations to be covered by a single NSEC3 record. In other words, use of the opt-out allows large registries to only sign as many NSEC3 records as there are signed DS or other RRsets in the zone; with opt-out, unsigned delegations do not require additional NSEC3 records. This sacrifices the tamper-resistance proof of non-existence offered by NSEC3 in order to reduce memory and CPU overheads, and decreases the effectiveness of the cache ([RFC 8198](#)).

Why would that ever be desirable? If a significant number of delegations are not yet securely delegated, meaning they lack DS records and are still insecure or unsigned, generating DNSSEC records for all their NS records might consume lots of memory and is not strictly required by the child zones.

This resource-saving typically makes a difference only for *huge* zones like `com.`. Imagine that you are the operator of busy top-level domains such as `com.`, with millions of insecure delegated domain names. As of mid-2022, around 3% of all `com.` zones are signed. Basically, without opt-out, with 1,000,000 delegations, only 30,000 of which are secure, you still have to generate NSEC RRsets for the other 970,000 delegations; with NSEC3 opt-out, you will have saved yourself 970,000 sets of records.

In contrast, for a small zone the difference is operationally negligible and the drawbacks outweigh the benefits.

If NSEC3 opt-out is truly essential for a zone, the following configuration can be added to `dnssec-policy`; for example, to create an NSEC3 chain using the SHA-1 hash algorithm, with the opt-out flag, no additional iterations, and no extra salt, use:

```
dnssec-policy "nsec3" {
    ...
    nsec3param iterations 0 optout yes salt-length 0;
};
```

To learn more about how to configure NSEC3 opt-out, please see [NSEC3 Opt-Out](#).

## NSEC3 Salt

### Warning

Contrary to popular belief, adding salt provides little value. Each DNS zone is always uniquely salted using the zone name. **Operators should use a zero-length salt value.**

The properties of this extra salt are complicated and beyond scope of this document. For detailed description why the salt in the context of DNSSEC provides little value please see [RFC 9276](#).

## NSEC or NSEC3?

So which is better: NSEC or NSEC3? There is no single right answer here that fits everyone; it comes down to a given network's needs or requirements.

In most cases, NSEC is a good choice for zone administrators. It relieves the authoritative servers and resolver of the additional cryptographic operations that NSEC3 requires, and NSEC is comparatively easier to troubleshoot than NSEC3.

NSEC3 comes with many drawbacks and should be implemented only if zone enumeration prevention is really needed, or when opt-out provides a significant reduction in memory and CPU overheads (in other words, with a huge zone with mostly insecure delegations).

## 11.7.3 DNSSEC Keys

### Types of Keys

Although DNSSEC documentation talks about three types of keys, they are all the same thing - but they have different roles. The roles are:

#### Zone-Signing Key (ZSK)

This is the key used to sign the zone. It signs all records in the zone apart from the DNSSEC key-related RRsets: DNSKEY, CDS, and CDNSKEY.

#### Key-Signing Key (KSK)

This is the key used to sign the DNSSEC key-related RRsets and is the key used to link the parent and child zones. The parent zone stores a digest of the KSK. When a resolver verifies the chain of trust it checks to see that the DS record in the parent (which holds the digest of a key) matches a key in the DNSKEY RRset, and that it is able to use that key to verify the DNSKEY RRset. If it can do that, the resolver knows that it can trust the DNSKEY resource records, and so can use one of them to validate the other records in the zone.

#### Combined Signing Key (CSK)

A CSK combines the functionality of a ZSK and a KSK. Instead of having one key for signing the zone and one for linking the parent and child zones, a CSK is a single key that serves both roles.

It is important to realize the terms ZSK, KSK, and CSK describe how the keys are used - all these keys are represented by DNSKEY records. The following examples are the DNSKEY records from a zone signed with a KSK and ZSK:

```
$ dig @192.168.1.12 example.com DNSKEY

; <<>> DiG 9.16.0 <<>> @192.168.1.12 example.com dnskey +multiline
; (1 server found)
;; global options: +cmd
;; Got answer:
;; ->>HEADER<<- opcode: QUERY, status: NOERROR, id: 54989
;; flags: qr aa rd; QUERY: 1, ANSWER: 2, AUTHORITY: 0, ADDITIONAL: 1
;; WARNING: recursion requested but not available
```

(continues on next page)

(continued from previous page)

```
;; OPT PSEUDOSECTION:
; EDNS: version: 0, flags;; udp: 4096
; COOKIE: 5258d7ed09db0d76010000005ea1cc8c672d8db27a464e37 (good)
;; QUESTION SECTION:
;example.com.          IN DNSKEY

;; ANSWER SECTION:
example.com.          60 IN DNSKEY 256 3 13 (
                        tAeXltIQ3aVDqqS/1UVRt9AE6/nzfoAuaT1Vy4dYl2CK
                        pLNcUJxME1Z//pnGXY+HqDU7Gr5HkJY8V0W3r5fzlw==
                        ) ; ZSK; alg = ECDSAP256SHA256 ; key id = 63722
example.com.          60 IN DNSKEY 257 3 13 (
                        cxkNegsgubBPXSra5ug2P8rWy63B8jTnS4n0IYSsD9eW
                        VhiyQDmdgevKUhfG3SE1wbLChjJc2FABvSZ1qk03Nw==
                        ) ; KSK; alg = ECDSAP256SHA256 ; key id = 42933
```

... and a zone signed with just a CSK:

```
$ dig @192.168.1.13 example.com DNSKEY

; <<>> DiG 9.16.0 <<>> @192.168.1.13 example.com dnskey +multiline
; (1 server found)
;; global options: +cmd
;; Got answer:
;; ->>HEADER<<- opcode: QUERY, status: NOERROR, id: 22628
;; flags: qr aa rd; QUERY: 1, ANSWER: 1, AUTHORITY: 0, ADDITIONAL: 1
;; WARNING: recursion requested but not available

;; OPT PSEUDOSECTION:
; EDNS: version: 0, flags;; udp: 4096
; COOKIE: bf19ee914b5df46e010000005ea1cd02b66c06885d274647 (good)
;; QUESTION SECTION:
;example.com.          IN DNSKEY

;; ANSWER SECTION:
example.com.          60 IN DNSKEY 257 3 13 (
                        p0XM6AJ68qid2vtOdyGaeH1jnrk2GhZeVvGzXfP/PNa
                        71wGtzR6jdUrTbXo5Z1W5QeeJF4dls4lh4z7DByF5Q==
                        ) ; KSK; alg = ECDSAP256SHA256 ; key id = 1231
```

The only visible difference between the records (apart from the key data itself) is the value of the flags fields; this is 256 for a ZSK and 257 for a KSK or CSK. Even then, the flags field is only a hint to the software using it as to the role of the key: zones can be signed by any key. The fact that a CSK and KSK both have the same flags emphasizes this. A KSK usually only signs the DNSSEC key-related RRsets in a zone, whereas a CSK is used to sign all records in the zone.

The original idea of separating the function of the key into a KSK and ZSK was operational. With a single key, changing it for any reason is "expensive," as it requires interaction with the parent zone (e.g., uploading the key to the parent may require manual interaction with the organization running that zone). By splitting it, interaction with the parent is required only if the KSK is changed; the ZSK can be changed as often as required without involving the parent.

The split also allows the keys to be of different lengths. So the ZSK, which is used to sign the record in the zone, can be of a (relatively) short length, lowering the load on the server. The KSK, which is used only infrequently, can be of a much longer length. The relatively infrequent use also allows the private part of the key to be stored in a way that is more

secure but that may require more overhead to access, e.g., on an HSM (see *Hardware Security Modules (HSMs)*).

In the early days of DNSSEC, the idea of splitting the key went more or less unchallenged. However, with the advent of more powerful computers and the introduction of signaling methods between the parent and child zones (see *The CDS and CDNSKEY Resource Records*), the advantages of a ZSK/KSK split are less clear and, for many zones, a single key is all that is required.

As with many questions related to the choice of DNSSEC policy, the decision on which is "best" is not clear and depends on your circumstances.

## Which Algorithm?

There are three algorithm choices for DNSSEC as of this writing (mid-2020):

- RSA
- Elliptic Curve DSA (ECDSA)
- Edwards Curve Digital Security Algorithm (EdDSA)

All are supported in BIND 9, but only RSA and ECDSA (specifically RSASHA256 and ECDSAP256SHA256) are mandatory to implement in DNSSEC. However, RSA is a little long in the tooth, and ECDSA/EdDSA are emerging as the next new cryptographic standards. In fact, the US federal government recommended discontinuing RSA use altogether by September 2015 and migrating to using ECDSA or similar algorithms.

For now, use ECDSAP256SHA256 but keep abreast of developments in this area. For details about rolling over DNSKEYs to a new algorithm, see *Algorithm Rollovers*.

## Key Sizes

If using RSA keys, the choice of key sizes is a classic issue of finding the balance between performance and security. The larger the key size, the longer it takes for an attacker to crack the key; but larger keys also mean more resources are needed both when generating signatures (authoritative servers) and verifying signatures (recursive servers).

Of the two sets of keys, ZSK is used much more frequently. ZSK is used whenever zone data changes or when signatures expire, so performance certainly is of a bigger concern. As for KSK, it is used less frequently, so performance is less of a factor, but its impact is bigger because of its role in signing other keys.

In earlier versions of this guide, the following key lengths were chosen for each set, with the recommendation that they be rotated more frequently for better security:

- ZSK: RSA 1024 bits, rollover every year
- KSK: RSA 2048 bits, rollover every five years

These should be considered minimum RSA key sizes. At the time of this writing (mid-2020), the root zone and many TLDs are already using 2048 bit ZSKs. If you choose to implement larger key sizes, keep in mind that larger key sizes result in larger DNS responses, which this may mean more load on network resources. Depending on your network configuration, end users may even experience resolution failures due to the increased response sizes, as discussed in *What's EDNS All About (And Why Should I Care)?*.

ECDSA key sizes can be much smaller for the same level of security, e.g., an ECDSA key length of 224 bits provides the same level of security as a 2048-bit RSA key. Currently BIND 9 sets a key size of 256 for all ECDSA keys.

## Key Storage

### Public Key Storage

The beauty of a public key cryptography system is that the public key portion can and should be distributed to as many people as possible. As the administrator, you may want to keep the public keys on an easily accessible file system for

operational ease, but there is no need to securely store them, since both ZSK and KSK public keys are published in the zone data as DNSKEY resource records.

Additionally, a hash of the KSK public key is also uploaded to the parent zone (see *Working With the Parent Zone* for more details), and is published by the parent zone as DS records.

### Private Key Storage

Ideally, private keys should be stored offline, in secure devices such as a smart card. Operationally, however, this creates certain challenges, since the private key is needed to create RRSIG resource records, and it is a hassle to bring the private key out of storage every time the zone file changes or signatures expire.

A common approach to strike the balance between security and practicality is to have two sets of keys: a ZSK set and a KSK set. A ZSK private key is used to sign zone data, and can be kept online for ease of use, while a KSK private key is used to sign just the DNSKEY (the ZSK); it is used less frequently, and can be stored in a much more secure and restricted fashion.

For example, a KSK private key stored on a USB flash drive that is kept in a fireproof safe, only brought online once a year to sign a new pair of ZSKs, combined with a ZSK private key stored on the network file system and available for routine use, may be a good balance between operational flexibility and security.

For more information on changing keys, please see *Key Rollovers*.

### Hardware Security Modules (HSMs)

A Hardware Security Module (HSM) may come in different shapes and sizes, but as the name indicates, it is a physical device or devices, usually with some or all of the following features:

- Tamper-resistant key storage
- Strong random-number generation
- Hardware for faster cryptographic operations

Most organizations do not incorporate HSMs into their security practices due to cost and the added operational complexity.

BIND supports Public Key Cryptography Standard #11 (PKCS #11) for communication with HSMs and other cryptographic support devices. For more information on how to configure BIND to work with an HSM, please refer to the [BIND 9 Administrator Reference Manual](#).

## 11.7.4 Rollovers

### Key Rollovers

A key rollover is where one key in a zone is replaced by a new one. There are arguments for and against regularly rolling keys. In essence these are:

Pros:

1. Regularly changing the key hinders attempts at determination of the private part of the key by cryptanalysis of signatures.
2. It gives administrators practice at changing a key; should a key ever need to be changed in an emergency, they would not be doing it for the first time.

Cons:

1. A lot of effort is required to hack a key, and there are probably easier ways of obtaining it, e.g., by breaking into the systems on which it is stored.
2. Rolling the key adds complexity to the system and introduces the possibility of error. We are more likely to have an interruption to our service than if we had not rolled it.

Whether and when to roll the key is up to you. How serious would the damage be if a key were compromised without you knowing about it? How serious would a key roll failure be?

Before going any further, it is worth noting that if you sign your zone with either of the fully automatic methods (described in ref:*signing\_alternative\_ways*), you don't really need to concern yourself with the details of a key rollover: BIND 9 takes care of it all for you. If you are doing a manual key roll or are setting up the keys for a semi-automatic key rollover, you do need to familiarize yourself with the various steps involved and the timing details.

Rolling a key is not as simple as replacing the DNSKEY statement in the zone. That is an essential part of it, but timing is everything. For example, suppose that we run the `example.com` zone and that a friend queries for the AAAA record of `www.example.com`. As part of the resolution process (described in *How Does DNSSEC Change DNS Lookup?*), their recursive server looks up the keys for the `example.com` zone and uses them to verify the signature associated with the AAAA record. We'll assume that the records validated successfully, so they can use the address to visit `example.com`'s website.

Let's also assume that immediately after the lookup, we want to roll the ZSK for `example.com`. Our first attempt at this is to remove the old DNSKEY record and signatures, add a new DNSKEY record, and re-sign the zone with it. So one minute our server is serving the old DNSKEY and records signed with the old key, and the next minute it is serving the new key and records signed with it. We've achieved our goal - we are serving a zone signed with the new keys; to check this is really the case, we booted up our laptop and looked up the AAAA record `ftp.example.com`. The lookup succeeded so all must be well. Or is it? Just to be sure, we called our friend and asked them to check. They tried to lookup `ftp.example.com` but got a SERVFAIL response from their recursive server. What's going on?

The answer, in a word, is "caching." When our friend looked up `www.example.com`, their recursive server retrieved and cached not only the AAAA record, but also a lot of other records. It cached the NS records for `com` and `example.com`, as well as the AAAA (and A) records for those name servers (and this action may, in turn, have caused the lookup and caching of other NS and AAAA/A records). Most importantly for this example, it also looked up and cached the DNSKEY records for the root, `com`, and `example.com` zones. When a query was made for `ftp.example.com`, the recursive server believed it already had most of the information we needed. It knew what nameservers served `example.com` and their addresses, so it went directly to one of those to get the AAAA record for `ftp.example.com` and its associated signature. But when it tried to validate the signature, it used the cached copy of the DNSKEY, and that is when our friend had the problem. Their recursive server had a copy of the old DNSKEY in its cache, but the AAAA record for `ftp.example.com` was signed with the new key. So, not surprisingly, the signature could not validate.

How should we roll the keys for `example.com`? A clue to the answer is to note that the problem came about because the DNSKEY records were cached by the recursive server. What would have happened had our friend flushed the DNSKEY records from the recursive server's cache before making the query? That would have worked; those records would have been retrieved from `example.com`'s nameservers at the same time that we retrieved the AAAA record for `ftp.example.com`. Our friend's server would have obtained the new key along with the AAAA record and associated signature created with the new key, and all would have been well.

As it is obviously impossible for us to notify all recursive server operators to flush our DNSKEY records every time we roll a key, we must use another solution. That solution is to wait for the recursive servers to remove old records from caches when they reach their TTL. How exactly we do this depends on whether we are trying to roll a ZSK, a KSK, or a CSK.

## ZSK Rollover Methods

The ZSK can be rolled in one of the following two ways:

1. *Pre-Publication*: Publish the new ZSK into zone data before it is actually used. Wait at least one TTL interval, so the world's recursive servers know about both keys, then stop using the old key and generate a new RRSIG using the new key. Wait at least another TTL, so the cached old key data is expunged from the world's recursive servers, and then remove the old key.

The benefit of the pre-publication approach is it does not dramatically increase the zone size; however, the duration of the rollover is longer. If insufficient time has passed after the new ZSK is published, some resolvers may only

have the old ZSK cached when the new RRSIG records are published, and validation may fail. This is the method described in [ZSK Rollover](#).

2. *Double-Signature*: Publish the new ZSK and new RRSIG, essentially doubling the size of the zone. Wait at least one TTL interval, and then remove the old ZSK and old RRSIG.

The benefit of the double-signature approach is that it is easier to understand and execute, but it causes a significantly increased zone size during a rollover event.

## KSK Rollover Methods

Rolling the KSK requires interaction with the parent zone, so operationally this may be more complex than rolling ZSKs. There are three methods of rolling the KSK:

1. *Double-KSK*: Add the new KSK to the DNSKEY RRset, which is then signed with both the old and new keys. After waiting for the old RRset to expire from caches, change the DS record in the parent zone. After waiting a further TTL interval for this change to be reflected in caches, remove the old key from the RRset.

Basically, the new KSK is added first at the child zone and used to sign the DNSKEY; then the DS record is changed, followed by the removal of the old KSK. Double-KSK keeps the interaction with the parent zone to a minimum, but for the duration of the rollover, the size of the DNSKEY RRset is increased.

2. *Double-DS*: Publish the new DS record. After waiting for this change to propagate into caches, change the KSK. After a further TTL interval during which the old DNSKEY RRset expires from caches, remove the old DS record.

Double-DS is the reverse of Double-KSK: the new DS is published at the parent first, then the KSK at the child is updated, then the old DS at the parent is removed. The benefit is that the size of the DNSKEY RRset is kept to a minimum, but interactions with the parent zone are increased to two events. This is the method described in [KSK Rollover](#).

3. *Double-RRset*: Add the new KSK to the DNSKEY RRset, which is then signed with both the old and new key, and add the new DS record to the parent zone. After waiting a suitable interval for the old DS and DNSKEY RRsets to expire from caches, remove the old DNSKEY and old DS record.

Double-RRset is the fastest way to roll the KSK (i.e., it has the shortest rollover time), but has the drawbacks of both of the other methods: a larger DNSKEY RRset and two interactions with the parent.

## CSK Rollover Methods

Rolling the CSK is more complex than rolling either the ZSK or KSK, as the timing constraints relating to both the parent zone and the caching of records by downstream recursive servers must be taken into account. There are numerous possible methods that are a combination of ZSK rollover and KSK rollover methods. BIND 9 automatic signing uses a combination of ZSK Pre-Publication and Double-KSK rollover.

## Emergency Key Rollovers

Keys are generally rolled on a regular schedule - if you choose to roll them at all. But sometimes, you may have to rollover keys out-of-schedule due to a security incident. The aim of an emergency rollover is to re-sign the zone with a new key as soon as possible, because when a key is suspected of being compromised, a malicious attacker (or anyone who has access to the key) could impersonate your server and trick other validating resolvers into believing that they are receiving authentic, validated answers.

During an emergency rollover, follow the same operational procedures described in [Rollovers](#), with the added task of reducing the TTL of the current active (potentially compromised) DNSKEY RRset, in an attempt to phase out the compromised key faster before the new key takes effect. The time frame should be significantly reduced from the 30-days-apart example, since you probably do not want to wait up to 60 days for the compromised key to be removed from your zone.

Another method is to carry a spare key with you at all times. If you have a second key pre-published and that one is not compromised at the same time as the first key, you could save yourself some time by immediately activating the spare key if the active key is compromised. With pre-publication, all validating resolvers should already have this spare key cached, thus saving you some time.

With a KSK emergency rollover, you also need to consider factors related to your parent zone, such as how quickly they can remove the old DS records and publish the new ones.

As with many other facets of DNSSEC, there are multiple aspects to take into account when it comes to emergency key rollovers. For more in-depth considerations, please check out [RFC 7583](#).

## Algorithm Rollovers

From time to time, new digital signature algorithms with improved security are introduced, and it may be desirable for administrators to roll over DNSKEYs to a new algorithm, e.g., from RSASHA1 (algorithm 5 or 7) to RSASHA256 (algorithm 8). The algorithm rollover steps must be followed with care to avoid breaking DNSSEC validation.

If you are managing DNSSEC by using the `dnssec-policy` configuration, `named` handles the rollover for you. Simply change the algorithm for the relevant keys, and `named` uses the new algorithm when the key is next rolled. It performs a smooth transition to the new algorithm, ensuring that the zone remains valid throughout rollover.

If you are using other methods to sign the zone, the administrator needs to do more work. As with other key rollovers, when the zone is a primary zone, an algorithm rollover can be accomplished using dynamic updates or automatic key rollovers. For secondary zones, only automatic key rollovers are possible, but the `dnssec-settime` utility can be used to control the timing.

In any case, the first step is to put DNSKEYs in place using the new algorithm. You must generate the `κ*` files for the new algorithm and put them in the zone's key directory, where `named` can access them. Take care to set appropriate ownership and permissions on the keys. If the `auto-dnssec` zone option is set to `maintain`, `named` automatically signs the zone with the new keys, based on their timing metadata when the `dnssec-loadkeys-interval` elapses or when you issue the `rndc loadkeys` command. Otherwise, for primary zones, you can use `nsupdate` to add the new DNSKEYs to the zone; this causes `named` to use them to sign the zone. For secondary zones, e.g., on a "bump in the wire" signing server, `nsupdate` cannot be used.

Once the zone has been signed by the new DNSKEYs (and you have waited for at least one TTL period), you must inform the parent zone and any trust anchor repositories of the new KSKs, e.g., you might place DS records in the parent zone through your DNS registrar's website.

Before starting to remove the old algorithm from a zone, you must allow the maximum TTL on its DS records in the parent zone to expire. This assures that any subsequent queries retrieve the new DS records for the new algorithm. After the TTL has expired, you can remove the DS records for the old algorithm from the parent zone and any trust anchor repositories. You must then allow another maximum TTL interval to elapse so that the old DS records disappear from all resolver caches.

The next step is to remove the DNSKEYs using the old algorithm from your zone. Again this can be accomplished using `nsupdate` to delete the old DNSKEYs (for primary zones only) or by automatic key rollover when `auto-dnssec` is set to `maintain`. You can cause the automatic key rollover to take place immediately by using the `dnssec-settime` utility to set the `Delete` date on all keys to any time in the past. (See the `dnssec-settime -D date/offset` option.)

After adjusting the timing metadata, the `rndc loadkeys` command causes `named` to remove the DNSKEYs and RRSIGs for the old algorithm from the zone. Note also that with the `nsupdate` method, removing the DNSKEYs also causes `named` to remove the associated RRSIGs automatically.

Once you have verified that the old DNSKEYs and RRSIGs have been removed from the zone, the final (optional) step is to remove the key files for the old algorithm from the key directory.

## 11.7.5 Other Topics

### DNSSEC and Dynamic Updates

Dynamic DNS (DDNS) is actually independent of DNSSEC. DDNS provides a mechanism, separate from editing the zone file or zone database, to edit DNS data. Most DNS clients and servers are able to handle dynamic updates, and DDNS can also be integrated as part of your DHCP environment.

When you have both DNSSEC and dynamic updates in your environment, updating zone data works the same way as with traditional (insecure) DNS: you can use `rndc freeze` before editing the zone file, and `rndc thaw` when you have finished editing, or you can use the command `nsupdate` to add, edit, or remove records like this:

```
$ nsupdate
> server 192.168.1.13
> update add xyz.example.com. 300 IN A 1.1.1.1
> send
> quit
```

The examples provided in this guide make `named` automatically re-sign the zone whenever its content has changed. If you decide to sign your own zone file manually, you need to remember to execute the `dnssec-signzone` command whenever your zone file has been updated.

As far as system resources and performance are concerned, be mindful that with a DNSSEC zone that changes frequently, every time the zone changes your system is executing a series of cryptographic operations to (re)generate signatures and NSEC or NSEC3 records.

### DNSSEC on Private Networks

Let's clarify what we mean: in this section, "private networks" really refers to a private or internal DNS view. Most DNS products offer the ability to have different versions of DNS answers, depending on the origin of the query. This feature is often called "DNS views" or "split DNS," and is most commonly implemented as an "internal" versus an "external" setup.

For instance, your organization may have a version of `example.com` that is offered to the world, and its names most likely resolve to publicly reachable IP addresses. You may also have an internal version of `example.com` that is only accessible when you are on the company's private networks or via a VPN connection. These private networks typically fall under 10.0.0.0/8, 172.16.0.0/12, or 192.168.0.0/16 for IPv4.

So what if you want to offer DNSSEC for your internal version of `example.com`? This can be done: the golden rule is to use the same key for both the internal and external versions of the zones. This avoids problems that can occur when machines (e.g., laptops) move between accessing the internal and external zones, when it is possible that they may have cached records from the wrong zone.

### Introduction to DANE

With your DNS infrastructure secured with DNSSEC, information can now be stored in DNS and its integrity and authenticity can be proved. One of the new features that takes advantage of this is the DNS-Based Authentication of Named Entities, or DANE. This improves security in a number of ways, including:

- The ability to store self-signed X.509 certificates and bypass having to pay a third party (such as a Certificate Authority) to sign the certificates ([RFC 6698](#)).
- Improved security for clients connecting to mail servers ([RFC 7672](#)).
- A secure way of getting public PGP keys ([RFC 7929](#)).

## 11.7.6 Disadvantages of DNSSEC

DNSSEC, like many things in this world, is not without its problems. Below are a few challenges and disadvantages that DNSSEC faces.

1. *Increased, well, everything:* With DNSSEC, signed zones are larger, thus taking up more disk space; for DNSSEC-aware servers, the additional cryptographic computation usually results in increased system load; and the network packets are bigger, possibly putting more strains on the network infrastructure.
2. *Different security considerations:* DNSSEC addresses many security concerns, most notably cache poisoning. But at the same time, it may introduce a set of different security considerations, such as amplification attack and zone enumeration through NSEC. These concerns are still being identified and addressed by the Internet community.
3. *More complexity:* If you have read this far, you have probably already concluded this yourself. With additional resource records, keys, signatures, and rotations, DNSSEC adds many more moving pieces on top of the existing DNS machine. The job of the DNS administrator changes, as DNS becomes the new secure repository of everything from spam avoidance to encryption keys, and the amount of work involved to troubleshoot a DNS-related issue becomes more challenging.
4. *Increased fragility:* The increased complexity means more opportunities for things to go wrong. Before DNSSEC, DNS was essentially "add something to the zone and forget it." With DNSSEC, each new component - re-signing, key rollover, interaction with parent zone, key management - adds more opportunity for error. It is entirely possible that a failure to validate a name may come down to errors on the part of one or more zone operators rather than the result of a deliberate attack on the DNS.
5. *New maintenance tasks:* Even if your new secure DNS infrastructure runs without any hiccups or security breaches, it still requires regular attention, from re-signing to key rollovers. While most of these can be automated, some of the tasks, such as KSK rollover, remain manual for the time being.
6. *Not enough people are using it today:* While it's estimated (as of mid-2020) that roughly 30% of the global Internet DNS traffic is validating,<sup>8</sup> that doesn't mean that many of the DNS zones are actually signed. What this means is, even if your company's zone is signed today, fewer than 30% of the Internet's servers are taking advantage of this extra security. It gets worse: with less than 1.5% of the `com.` domains signed, even if your DNSSEC validation is enabled today, it's not likely to buy you or your users a whole lot more protection until these popular domain names decide to sign their zones.

The last point may have more impact than you realize. Consider this: HTTP and HTTPS make up the majority of traffic on the Internet. While you may have secured your DNS infrastructure through DNSSEC, if your web hosting is outsourced to a third party that does not yet support DNSSEC in its own domain, or if your web page loads contents and components from insecure domains, end users may experience validation problems when trying to access your web page. For example, although you may have signed the zone `company.com`, the web address `www.company.com` may actually be a CNAME to `foo.random-cloud-provider.com`. As long as `random-cloud-provider.com` remains an insecure DNS zone, users cannot fully validate everything when they visit your web page and could be redirected elsewhere by a cache poisoning attack.

## 11.8 Recipes

This chapter provides step-by-step "recipes" for some common DNSSEC configurations.

### 11.8.1 DNSSEC Signing

There are two recipes here: the first shows an example using DNSSEC signing on the primary server, which has been covered in this guide; the second shows how to setup a "bump in the wire" between a hidden primary and the secondary servers to seamlessly sign the zone "on the fly."

<sup>8</sup> Based on APNIC statistics at <https://stats.labs.apnic.net/dnssec/XA>

## Primary Server DNSSEC Signing

In this recipe, our servers are illustrated as shown in *DNSSEC Signing Recipe #1*: we have a primary server (192.168.1.1) and three secondary servers (192.168.1.2, 192.168.1.3, and 192.168.1.4) that receive zone transfers. To get the zone signed, we need to reconfigure the primary server. Once reconfigured, a signed version of the zone is generated on the fly; zone transfers take care of synchronizing the signed zone data to all secondary name servers, without configuration or software changes on them.

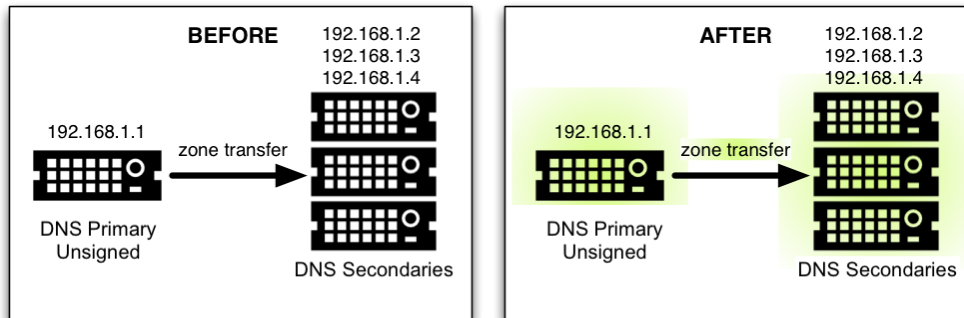

Fig. 5: DNSSEC Signing Recipe #1

Using the method described in *Easy-Start Guide for Signing Authoritative Zones*, we just need to add a `dnssec-policy` statement to the relevant zone clause. This is what the `named.conf` zone statement looks like on the primary server, 192.168.1.1:

```
zone "example.com" IN {
    type primary;
    file "db/example.com.db";
    key-directory "keys/example.com";
    dnssec-policy default;
    inline-signing yes;
    allow-transfer { 192.168.1.2; 192.168.1.3; 192.168.1.4; };
};
```

We have chosen to use the default policy, storing the keys generated for the zone in the directory `keys/example.com`. To use a custom policy, define the policy in the configuration file and select it in the zone statement (as described in *Creating a Custom DNSSEC Policy*).

On the secondary servers, `named.conf` does not need to be updated, and it looks like this:

```
zone "example.com" IN {
    type secondary;
    file "db/example.com.db";
    primaries { 192.168.1.1; };
};
```

In fact, the secondary servers do not even need to be running BIND; they can run any DNS product that supports DNSSEC.

## "Bump in the Wire" Signing

In this recipe, we take advantage of the power of automated signing by placing an additional name server (192.168.1.5) between the hidden primary (192.168.1.1) and the DNS secondaries (192.168.1.2, 192.168.1.3, and 192.168.1.4). The additional name server, 192.168.1.5, acts as a "bump in the wire," taking an unsigned zone from the hidden primary, and sending out signed data on the other end to the secondary name servers. The steps described in this recipe may be

used as part of a DNSSEC deployment strategy, since it requires only minimal changes made to the existing hidden DNS primary and DNS secondaries.

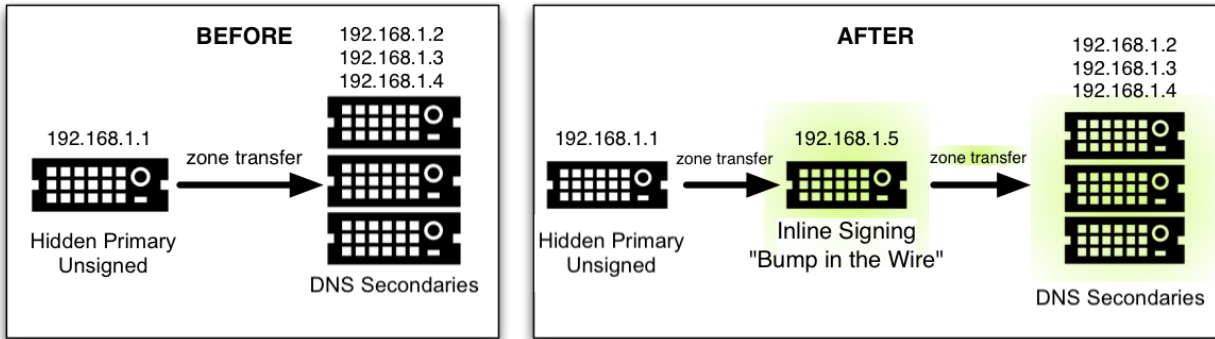

Fig. 6: DNSSEC Signing Recipe #2

It is important to remember that 192.168.1.1 in this case is a hidden primary not exposed to the world, and it must not be listed in the NS RRset. Otherwise the world will get conflicting answers: unsigned answers from the hidden primary and signed answers from the other name servers.

The only configuration change needed on the hidden primary, 192.168.1.1, is to make sure it allows our middle box to perform a zone transfer:

```
zone "example.com" IN {
    ...
    allow-transfer { 192.168.1.5; };
    ...
};
```

On the middle box, 192.168.1.5, all the tasks described in *Easy-Start Guide for Signing Authoritative Zones* still need to be performed, such as generating key pairs and uploading information to the parent zone. This server is configured as secondary to the hidden primary 192.168.1.1 to receive the unsigned data; then, using keys accessible to this middle box, to sign data on the fly; and finally, to send out the signed data via zone transfer to the other three DNS secondaries. Its *named.conf* zone statement looks like this:

```
zone example.com {
    type secondary;
    primaries { 192.168.1.1; };
    file "db/example.com.db";
    key-directory "keys/example.com";
    dnssec-policy default;
    inline-signing yes;
    allow-transfer { 192.168.1.2; 192.168.1.3; 192.168.1.4; };
};
```

(As before, the default policy has been selected here. See *Creating a Custom DNSSEC Policy* for instructions on how to define and use a custom policy.)

Finally, on the three secondary servers, the configuration should be updated to receive a zone transfer from 192.168.1.5 (the middle box) instead of from 192.168.1.1 (the hidden primary). If using BIND, the *named.conf* file looks like this:

```
zone "example.com" IN {
    type secondary;
```

(continues on next page)

(continued from previous page)

```
file "db/example.com.db";
primaries { 192.168.1.5; }; # this was 192.168.1.1 before!
};
```

## 11.8.2 Rollovers

If you are signing your zone using a *dnssec-policy* statement, this section is not really relevant to you. In the policy statement, you set how long you want your keys to be valid for, the time taken for information to propagate through your zone, the time it takes for your parent zone to register a new DS record, etc., and that's more or less it. *named* implements everything for you automatically, apart from uploading the new DS records to your parent zone - which is covered in *Uploading Information to the Parent Zone*. (Some screenshots from a session where a KSK is uploaded to the parent zone are presented here for convenience.) However, these recipes may be useful in describing what happens through the rollover process and what you should be monitoring.

### ZSK Rollover

This recipe covers how to perform a ZSK rollover using what is known as the Pre-Publication method. For other ZSK rolling methods, please see *ZSK Rollover Methods* in *Advanced Discussions*.

Below is a sample timeline for a ZSK rollover to occur on January 1, 2021:

1. December 1, 2020 (one month before rollover)
  - Generate new ZSK
  - Add DNSKEY for new ZSK to zone
2. January 1, 2021 (day of rollover)
  - New ZSK used to replace RRSIGs for the bulk of the zone
3. February 1, 2021 (one month after rollover)
  - Remove old ZSK DNSKEY RRset from zone
  - DNSKEY signatures made with KSK are changed

The current active ZSK has the ID 17694 in the example below. For more information on key management and rollovers, please see *Rollovers*.

### One Month Before ZSK Rollover

On December 1, 2020, a month before the example rollover, you (as administrator) should change the parameters on the current key (17694). Set it to become inactive on January 1, 2021 and be deleted from the zone on February 1, 2021; also, generate a successor key (51623):

```
# cd /etc/bind/keys/example.com/
# dnssec-settime -I 20210101 -D 20210201 Kexample.com.+008+17694
./Kexample.com.+008+17694.key/GoDaddy

./Kexample.com.+008+17694.private
# dnssec-keygen -S Kexample.com.+008+17694
Generating key pair..+++++ .....+++++
Kexample.com.+008+51623
```

The first command gets us into the key directory `/etc/bind/keys/example.com/`, where keys for `example.com` are stored.

The second, `dnssec-settime`, sets an inactive (`-I`) date of January 1, 2021, and a deletion (`-D`) date of February 1, 2021, for the current ZSK (`Kexample.com.+008+17694`).

The third command, `dnssec-keygen`, creates a successor key, using the exact same parameters (algorithms, key sizes, etc.) as the current ZSK. The new ZSK created in our example is `Kexample.com.+008+51623`.

Make sure the successor keys are readable by `named`.

`named`'s logging messages indicate when the next key checking event is scheduled to occur, the frequency of which can be controlled by `dnssec-loadkeys-interval`. The log message looks like this:

```
zone example.com/IN (signed): next key event: 01-Dec-2020 00:13:05.385
```

And you can check the publish date of the key by looking at the key file:

```
# cd /etc/bind/keys/example.com
# cat Kexample.com.+008+51623.key
; This is a zone-signing key, keyid 11623, for example.com.
; Created: 20201130160024 (Mon Dec 1 00:00:24 2020)
; Publish: 20201202000000 (Fri Dec 2 08:00:00 2020)
; Activate: 20210101000000 (Sun Jan 1 08:00:00 2021)
...
```

Since the publish date is set to the morning of December 2, and our example scenario takes place on December 1, the next morning you will notice that your zone has gained a new DNSKEY record, but the new ZSK is not yet being used to generate signatures. Below is the abbreviated output - with shortened DNSKEY and RRSIG - when querying the authoritative name server, 192.168.1.13:

```
$ dig @192.168.1.13 example.com. DNSKEY +dnssec +multiline
...
;; ANSWER SECTION:
example.com.      600 IN DNSKEY 257 3 8 (
    AwEAAcWDps...lM3NRn/G/R
    ) ; KSK; alg = RSASHA256; key id = 6817
example.com.      600 IN DNSKEY 256 3 8 (
    AwEAAbi6Vo...qBW5+iAqNz
    ) ; ZSK; alg = RSASHA256; key id = 51623
example.com.      600 IN DNSKEY 256 3 8 (
    AwEAAcjGaU...0rzuu55If5
    ) ; ZSK; alg = RSASHA256; key id = 17694
example.com.      600 IN RRSIG DNSKEY 8 2 600 (
    20210101000000 20201201230000 6817 example.com.
    LAiaJM26T7...FU9syh/TQ= )
example.com.      600 IN RRSIG DNSKEY 8 2 600 (
    20210101000000 20201201230000 17694 example.com.
    HK4EBbbOpj...n5V6nvAkI= )
...
```

For good measure, let's take a look at the SOA record and its signature for this zone. Notice the RRSIG is signed by the current ZSK, 17694. This will come in handy later when you want to verify whether the new ZSK is in effect:

```
$ dig @192.168.1.13 example.com. SOA +dnssec +multiline
...
;; ANSWER SECTION:
```

(continues on next page)

(continued from previous page)

```
example.com.      600 IN SOA ns1.example.com. admin.example.com. (
    2020120102 ; serial
    1800      ; refresh (30 minutes)
    900      ; retry (15 minutes)
    2419200  ; expire (4 weeks)
    300      ; minimum (5 minutes)
)
example.com.      600 IN RRSIG SOA 8 2 600 (
    20201230160109 20201130150109 17694 example.com.
    YUTC8rFULaWbW+nAHzbfGwNqzARHevpryzRIJMvZBYPo
    NAeejNk9saNAoCYKWxGJ0YBc2k+r5fYq1Mg4112JkBF5
    buAsAYLw8vEOIxVpXwlArY+oSp9T1w2wfTZ0vhVIxaYX
    6dkcz4I3wbDx2xmG0yngtA6A8lAchERx2EGy0RM= )
```

These are all the manual tasks you need to perform for a ZSK rollover. If you have followed the configuration examples in this guide of using *inline-signing* and *auto-dnssec*, everything else is automated for you by BIND.

### Day of ZSK Rollover

On the actual day of the rollover, although there is technically nothing for you to do, you should still keep an eye on the zone to make sure new signatures are being generated by the new ZSK (51623 in this example). The easiest way is to query the authoritative name server 192.168.1.13 for the SOA record as you did a month ago:

```
$ dig @192.168.1.13 example.com. SOA +dnssec +multiline
...
;; ANSWER SECTION:
example.com.      600 IN SOA ns1.example.com. admin.example.com. (
    2020112011 ; serial
    1800      ; refresh (30 minutes)
    900      ; retry (15 minutes)
    2419200  ; expire (4 weeks)
    300      ; minimum (5 minutes)
)
example.com.      600 IN RRSIG SOA 8 2 600 (
    20210131000000 20201231230000 51623 example.com.
    J4RMNpJPomMidElyBugJp0RLqXoNqfvo/2AT6yAAvx9X
    zZRL1cuhkRcyCSLZ9Z+zZ2y4u21vQGrNiondaKdQCor7
    uTqH5WCPoqalOCBjqU7c7v1AM27O9RD11nzPNpVQ7xPs
    y5nkGqf830XTK26IfnjU1jqiuKSzg6QR7+XpLk0= )
...
```

As you can see, the signature generated by the old ZSK (17694) has disappeared, replaced by a new signature generated from the new ZSK (51623).

**Note**

Not all signatures will disappear magically on the same day; it depends on when each one was generated. In the worst-case scenario, a new signature could have been signed by the old ZSK (17694) moments before it was deactivated, meaning that the signature could live for almost 30 more days, until just before February 1.

This is why it is important to keep the old ZSK in the zone and not delete it right away.

## One Month After ZSK Rollover

Again, technically there is nothing you need to do on this day, but it doesn't hurt to verify that the old ZSK (17694) is now completely gone from your zone. *named* will not touch `Kexample.com.+008+17694.private` and `Kexample.com.+008+17694.key` on your file system. Running the same *dig* command for DNSKEY should suffice:

```
$ dig @192.168.1.13 example.com. DNSKEY +multiline +dnssec
...
;; ANSWER SECTION:
example.com.      600 IN DNSKEY 257 3 8 (
                    AwEAAcWDps...lM3NRn/G/R
                    ) ; KSK; alg = RSASHA256; key id = 6817
example.com.      600 IN DNSKEY 256 3 8 (
                    AwEAAdeCGr...1DnEfX+Xzn
                    ) ; ZSK; alg = RSASHA256; key id = 51623
example.com.      600 IN RRSIG DNSKEY 8 2 600 (
                    20170203000000 20170102230000 6817 example.com.
                    KHYP0zE21...Y3szrmjAM= )
example.com.      600 IN RRSIG DNSKEY 8 2 600 (
                    20170203000000 20170102230000 51623 example.com.
                    G2g3crN17h...Oe4gw6gH8= )
...
```

Congratulations, the ZSK rollover is complete! As for the actual key files (the files ending in `.key` and `.private`), they may be deleted at this point, but they do not have to be.

## KSK Rollover

This recipe describes how to perform KSK rollover using the Double-DS method. For other KSK rolling methods, please see *KSK Rollover Methods* in *Advanced Discussions*. The registrar used in this recipe is *GoDaddy*. Also for this recipe, we are keeping the number of DS records down to just one per active set using just SHA-1, for the sake of better clarity, although in practice most zone operators choose to upload two DS records as shown in *Working With the Parent Zone*. For more information on key management and rollovers, please see *Rollovers*.

Below is a sample timeline for a KSK rollover to occur on January 1, 2021:

1. December 1, 2020 (one month before rollover)
  - Change timer on the current KSK
  - Generate new KSK and DS records
  - Add DNSKEY for the new KSK to zone
  - Upload new DS records to parent zone
2. January 1, 2021 (day of rollover)
  - Use the new KSK to sign all DNSKEY RRsets, which generates new RRSIGs
  - Add new RRSIGs to the zone
  - Remove RRSIG for the old ZSK from zone
  - Start using the new KSK to sign DNSKEY
3. February 1, 2021 (one month after rollover)
  - Remove the old KSK DNSKEY from zone
  - Remove old DS records from parent zone

The current active KSK has the ID 24828, and this is the DS record that has already been published by the parent zone:

```
# dnssec-dsfromkey -a SHA-1 Kexample.com.+007+24828.key
example.com. IN DS 24828 7 1 D4A33E8DD550A9567B4C4971A34AD6C4B80A6AD3
```

**One Month Before KSK Rollover**

On December 1, 2020, a month before the planned rollover, you (as administrator) should change the parameters on the current key. Set it to become inactive on January 1, 2021, and be deleted from the zone on February 1st, 2021; also generate a successor key (23550). Finally, generate a new DS record based on the new key, 23550:

```
# cd /etc/bind/keys/example.com/
# dnssec-settime -I 20210101 -D 20210201 Kexample.com.+007+24828
./Kexample.com.+007+24848.key
./Kexample.com.+007+24848.private
# dnssec-keygen -S Kexample.com.+007+24848
Generating key pair.....
→.....++ .....++
Kexample.com.+007+23550
# dnssec-dsfromkey -a SHA-1 Kexample.com.+007+23550.key
example.com. IN DS 23550 7 1 54FCF030AA1C79C0088FDEC1BD1C37DAA2E70DFB
```

The first command gets us into the key directory `/etc/bind/keys/example.com/`, where keys for `example.com` are stored.

The second, `dnssec-settime`, sets an inactive (`-I`) date of January 1, 2021, and a deletion (`-D`) date of February 1, 2021 for the current KSK (`Kexample.com.+007+24848`).

The third command, `dnssec-keygen`, creates a successor key, using the exact same parameters (algorithms, key sizes, etc.) as the current KSK. The new key pair created in our example is `Kexample.com.+007+23550`.

The fourth and final command, `dnssec-dsfromkey`, creates a DS record from the new KSK (23550), using SHA-1 as the digest type. Again, in practice most people generate two DS records for both supported digest types (SHA-1 and SHA-256), but for our example here we are only using one to keep the output small and hopefully clearer.

Make sure the successor keys are readable by `named`.

The `syslog` message indicates when the next key checking event is. The log message looks like this:

```
zone example.com/IN (signed): next key event: 01-Dec-2020 00:13:05.385
```

You can check the publish date of the key by looking at the key file:

```
# cd /etc/bind/keys/example.com
# cat Kexample.com.+007+23550.key
; This is a key-signing key, keyid 23550, for example.com.
; Created: 20201130160024 (Thu Dec 1 00:00:24 2020)
; Publish: 20201202000000 (Fri Dec 2 08:00:00 2020)
; Activate: 20210101000000 (Sun Jan 1 08:00:00 2021)
...
```

Since the publish date is set to the morning of December 2, and our example scenario takes place on December 1, the next morning you will notice that your zone has gained a new DNSKEY record based on your new KSK, but with no corresponding RRSIG yet. Below is the abbreviated output - with shortened DNSKEY and RRSIG - when querying the authoritative name server, 192.168.1.13:

```
$ dig @192.168.1.13 example.com. DNSKEY +dnssec +multiline
...
;; ANSWER SECTION:
example.com. 300 IN DNSKEY 256 3 7 (
    AwEAAAdYqAc...Tislrma6Ef
    ) ; ZSK; alg = NSEC3RSASHA1; key id = 29747
example.com. 300 IN DNSKEY 257 3 7 (
    AwEAAeTJ+w...O+Zy9j0m63
    ) ; KSK; alg = NSEC3RSASHA1; key id = 24828
example.com. 300 IN DNSKEY 257 3 7 (
    AwEAAc1BQN...Wdc0qoH21H
    ) ; KSK; alg = NSEC3RSASHA1; key id = 23550
example.com. 300 IN RRSIG DNSKEY 7 2 300 (
    20201206125617 20201107115617 24828 example.com.
    4y1iPVJOrK...aC3iF9vqc= )
example.com. 300 IN RRSIG DNSKEY 7 2 300 (
    20201206125617 20201107115617 29747 example.com.
    g/gfmPjr+y...rt/S/xjPo= )
...
```

Anytime after generating the DS record, you can upload it; it is not necessary to wait for the DNSKEY to be published in your zone, since this new KSK is not active yet. You can do it immediately after the new DS record has been generated on December 1, or you can wait until the next day after you have verified that the new DNSKEY record is added to the zone. Below are some screenshots from GoDaddy's web-based interface, used to add a new DS record.<sup>9</sup>

1. After logging in, click the green "Launch" button next to the domain name you want to manage.

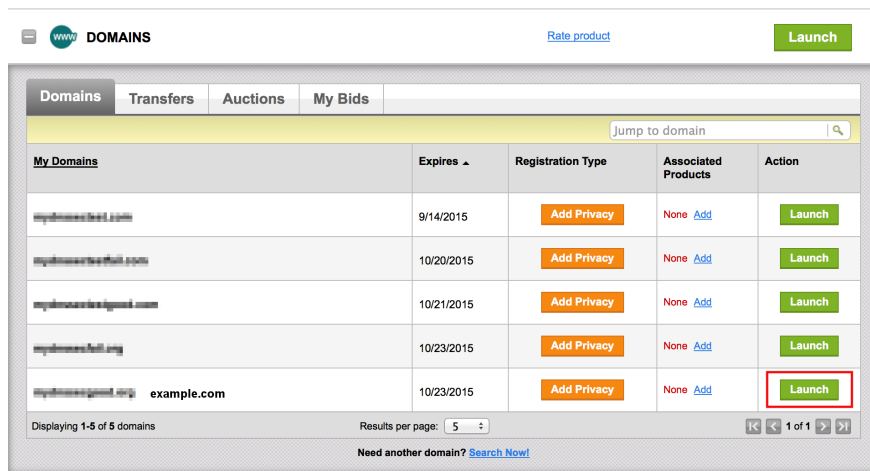

Fig. 7: Upload DS Record Step #1

2. Scroll down to the "DS Records" section and click "Manage."
3. A dialog appears, displaying the current key (24828). Click "Add DS Record."
4. Enter the Key ID, algorithm, digest type, and the digest, then click "Next."
5. Address any errors and click "Finish."

<sup>9</sup> The screenshots were taken from GoDaddy's interface at the time the original version of this guide was published (2015). It may have changed since then.

Settings | DNS Zone File | Contacts

### Domain Settings

**Auto-Renew** ⓘ      **Standard:** On  
**Extended:** Off  
[Manage](#)

---

**Lock** ⓘ              On  
[Manage](#)

---

**Nameservers** ⓘ      [REDACTED]  
[REDACTED]  
Updated 10/24/2014  
[Manage](#)

---

**Forwarding** ⓘ        **Domain:** Off  
[Manage](#)

**Subdomain:** 0 subdomains forwarded  
[Manage](#)

---

**Premium DNS** ⓘ     **Expires:** 10/21/2015  
[Manage](#)

**Secondary DNS:** Off  
[Manage](#)

**DNSSEC:** Unavailable  
[Manage](#)

**Vanity Nameservers:** Off  
[Manage](#)

---

**DS Records** ⓘ      1 DS record created  
[Manage](#)

Fig. 8: Upload DS Record Step #2

Manage DNSSEC DS Records ×

**[REDACTED]**

Choose how to set up your DS records.

Key tag	Algorithm	Digest Type	Digest	Max Sig Life	Flags	Protocol	Key Data Alg	Public Key
24828	7	1	D4A33E8DD550A9...	1814400	N/A	N/A	N/A	

[Add DS Record](#)

Fig. 9: Upload DS Record Step #3

Fig. 10: Upload DS Record Step #4

Key tag	Algorithm	Digest Type	Digest	Max Sig Life	Flags	Protocol	Key Data Alg	Public Key	Error
23550	7	1	54FCF030...	N/A	N/A	N/A	N/A	N/A	N/A

Fig. 11: Upload DS Record Step #5

6. Both DS records are shown. Click "Save."

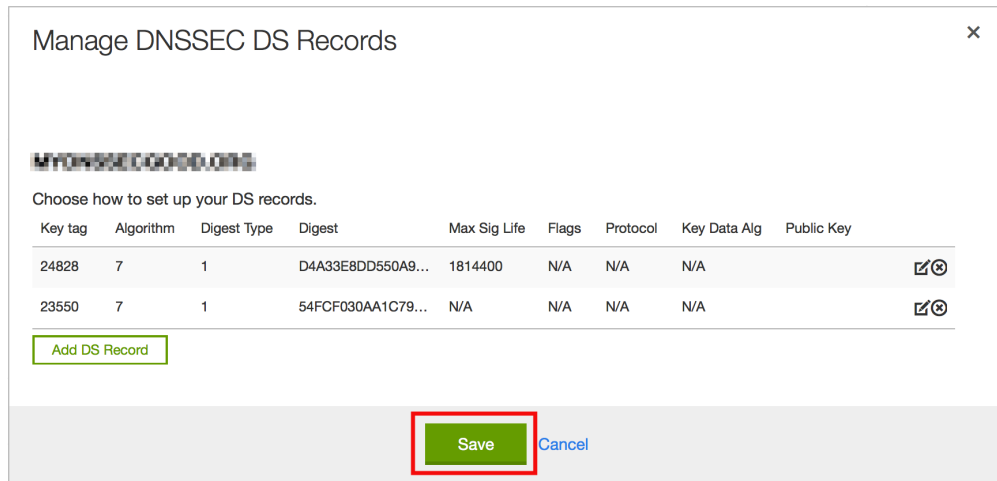

Fig. 12: Upload DS Record Step #6

Finally, let's verify that the registrar has published the new DS record. This may take anywhere from a few minutes to a few days, depending on your parent zone. You can verify whether your parent zone has published the new DS record by querying for the DS record of your zone. In the example below, the Google public DNS server 8.8.8.8 is used:

```
$ dig @8.8.8.8 example.com. DS
...
;; ANSWER SECTION:
example.com.      21552    IN      DS      24828 7 1 D4A33E8DD550A9567B4C4971A34AD6C4B80A6AD3
example.com.      21552    IN      DS      23550 7 1 54FCF030AA1C79C0088FDEC1BD1C37DAA2E70DFB
```

You can also query your parent zone's authoritative name servers directly to see if these records have been published. DS records will not show up on your own authoritative zone, so you cannot query your own name servers for them. In this recipe, the parent zone is .com, so querying a few of the .com name servers is another appropriate verification.

### Day of KSK Rollover

If you have followed the examples in this document, as described in *Easy-Start Guide for Signing Authoritative Zones*, there is technically nothing you need to do manually on the actual day of the rollover. However, you should still keep an eye on the zone to make sure new signature(s) are being generated by the new KSK (23550 in this example). The easiest way is to query the authoritative name server 192.168.1.13 for the same DNSKEY and signatures, as you did a month ago:

```
$ dig @192.168.1.13 example.com. DNSKEY +dnssec +multiline
...
;; ANSWER SECTION:
example.com.      300 IN  DNSKEY 256 3 7 (
    AwEAAAdYqAc...TiSlrma6Ef
    ) ; ZSK; alg = NSEC3RSASHA1; key id = 29747
example.com.      300 IN  DNSKEY 257 3 7 (
    AwEAAeTJ+w...O+Zy9j0m63
    ) ; KSK; alg = NSEC3RSASHA1; key id = 24828
example.com.      300 IN  DNSKEY 257 3 7 (
```

(continues on next page)

(continued from previous page)

```

                AwEAAc1BQN...Wdc0qoH21H
                ) ; KSK; alg = NSEC3RSASHA1; key id = 23550
example.com.   300 IN RRSIG DNSKEY 7 2 300 (
                20210201074900 20210101064900 23550 mydnssecgood.org.
                S6zTbBTfvU...Ib5eXkbtE= )
example.com.   300 IN RRSIG DNSKEY 7 2 300 (
                20210105074900 20201206064900 29747 mydnssecgood.org.
                VY5URQA2/d...OVKrl+KX8= )
...

```

As you can see, the signature generated by the old KSK (24828) has disappeared, replaced by a new signature generated from the new KSK (23550).

### One Month After KSK Rollover

While the removal of the old DNSKEY from the zone should be automated by *named*, the removal of the DS record is manual. You should make sure the old DNSKEY record is gone from your zone first, by querying for the DNSKEY records of the zone; this time we expect not to see the key with an ID of 24828:

```

$ dig @192.168.1.13 example.com. DNSKEY +dnssec +multiline
...
;; ANSWER SECTION:
example.com.   300 IN DNSKEY 256 3 7 (
                AwEAAAdYqAc...Tislrma6Ef
                ) ; ZSK; alg = NSEC3RSASHA1; key id = 29747
example.com.   300 IN DNSKEY 257 3 7 (
                AwEAAc1BQN...Wdc0qoH21H
                ) ; KSK; alg = NSEC3RSASHA1; key id = 23550
example.com.   300 IN RRSIG DNSKEY 7 2 300 (
                20210208000000 20210105230000 23550 mydnssecgood.org.
                Qw9Em3dDok...bNCS7KISw= )
example.com.   300 IN RRSIG DNSKEY 7 2 300 (
                20210208000000 20210105230000 29747 mydnssecgood.org.
                OuelpIlpY9...XfsKupQgc= )
...

```

Since the key with the ID 24828 is gone, you can now remove the old DS record for that key from our parent zone. Be careful to remove the correct DS record. If you accidentally remove the new DS record(s) with key ID 23550, it could lead to a problem called "security lameness," as discussed in *Security Lameness*, and may cause users to be unable to resolve any names in the zone.

1. After logging in (again, GoDaddy.com in our example) and launching the domain, scroll down to the "DS Records" section and click Manage.
2. A dialog appears, displaying both keys (24828 and 23550). Use the far right-hand X button to remove key 24828.
3. Key 24828 now appears crossed out; click "Save" to complete the removal.

Congratulations, the KSK rollover is complete! As for the actual key files (ending in `.key` and `.private`), they may be deleted at this point, but they do not have to be.

Domain Settings

---

**Auto-Renew** ⓘ **Standard:** On  
**Extended:** Off  
[Manage](#)

---

**Lock** ⓘ On  
[Manage](#)

---

**Nameservers** ⓘ   
Updated 10/24/2014  
[Manage](#)

---

**Forwarding** ⓘ **Domain:** Off  
[Manage](#)

**Subdomain:** 0 subdomains forwarded  
[Manage](#)

---

**Premium DNS** ⓘ **Expires:** 10/21/2015  
[Manage](#)

**Secondary DNS:** Off  
[Manage](#)

**DNSSEC:** Unavailable  
[Manage](#)

**Vanity Nameservers:** Off  
[Manage](#)

---





**DS Records** ⓘ 2 DS records created  
[Manage](#)

Fig. 13: Remove DS Record Step #1

Manage DNSSEC DS Records ×



Choose how to set up your DS records.

Key tag	Algorithm	Digest Type	Digest	Max Sig Life	Flags	Protocol	Key Data Alg	Public Key
23550	7	1	54FCF030AA1C79...	1814400	N/A	N/A	N/A	 
24828	7	1	D4A33E8DD550A9...	1814400	N/A	N/A	N/A	 

[Add DS Record](#)

Fig. 14: Remove DS Record Step #2

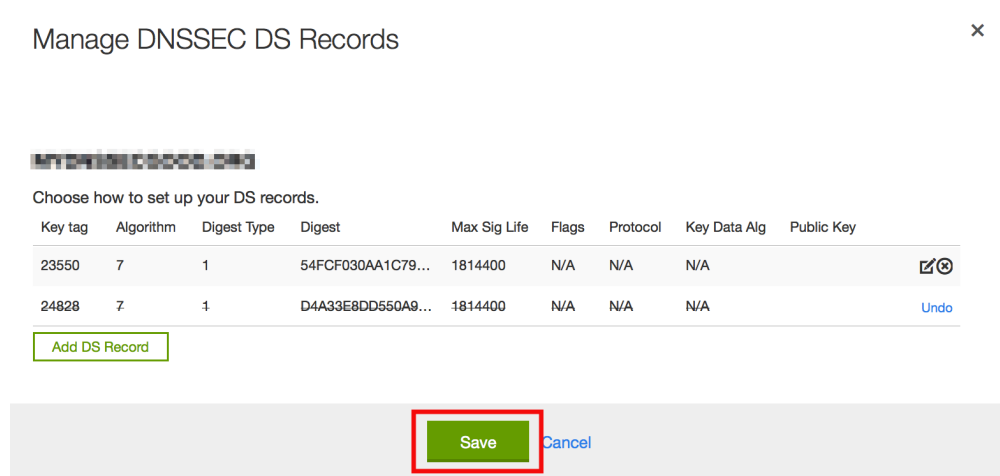

Fig. 15: Remove DS Record Step #3

### 11.8.3 NSEC and NSEC3

#### Migrating from NSEC to NSEC3

This recipe describes how to transition from using NSEC to NSEC3, as described in *Proof of Non-Existence (NSEC and NSEC3)*. This recipe assumes that the zones are already signed, and that `named` is configured according to the steps described in *Easy-Start Guide for Signing Authoritative Zones*.

#### Warning

If your zone is signed with RSASHA1 (algorithm 5), you cannot migrate to NSEC3 without also performing an algorithm rollover to RSASHA1-NSEC3-SHA1 (algorithm 7), as described in *Algorithm Rollovers*. This ensures that older validating resolvers that do not understand NSEC3 will fall back to treating the zone as unsecured (rather than "bogus"), as described in Section 2 of [RFC 5155](#).

To enable NSEC3, update your `dnssec-policy` and add the desired NSEC3 parameters. The example below enables NSEC3 for zones with the `standard` DNSSEC policy, using 0 additional iterations, no opt-out, and a zero-length salt:

```
dnssec-policy "standard" {
    nsec3param iterations 0 optout no salt-length 0;
};
```

Then reconfigure the server with `rndc`. You can tell that it worked if you see the following debug log messages:

```
Oct 21 13:47:21 received control channel command 'reconfig'
Oct 21 13:47:21 zone example.com/IN (signed): zone_addnsec3chain(1,CREATE,0,-)
```

You can also verify that it worked by querying for a name that you know does not exist, and checking for the presence of the NSEC3 record. For example:

```
$ dig @192.168.1.13 thereisnowaythisexists.example.com. A +dnssec +multiline
...
5A03TL362CS8VSIH69CVA4MJIKRHFQH3.example.com. 300 IN NSEC3 1 0 0 - (
    TQ9QBEGA6CROHEOC8KIH1A2C06IVQ5ER
```

(continues on next page)

(continued from previous page)

```
...
NS SOA RRSIG DNSKEY NSEC3PARAM )
...
```

Our example used four parameters: 1, 0, 0, and -, in order. 1 represents the algorithm, 0 represents the opt-out flag, 0 represents the number of additional iterations, and - denotes no salt is used. To learn more about each of these parameters, please see [NSEC3PARAM](#).

### Migrating from NSEC3 to NSEC

Migrating from NSEC3 back to NSEC is easy; just remove the `nsec3param` configuration option from your `dnssec-policy` and reconfigure the name server. You can tell that it worked if you see these messages in the log:

```
named[14093]: received control channel command 'reconfig'
named[14093]: zone example.com/IN: zone_addnsec3chain(1,REMOVE,0,-)
```

You can also query for a name that you know does not exist, and you should no longer see any traces of NSEC3 records.

```
$ dig @192.168.1.13 reieiergiuhewhiouwe.example.com. A +dnssec +multiline
...
example.com.          300 IN NSEC aaa.example.com. NS SOA RRSIG NSEC DNSKEY
...
ns1.example.com.     300 IN NSEC web.example.com. A RRSIG NSEC
...
```

### NSEC3 Opt-Out

This recipe discusses how to enable and disable NSEC3 opt-out, and how to show the results of each action. As discussed in [NSEC3 Opt-Out](#), NSEC3 opt-out is a feature that can help conserve resources on parent zones with many delegations that have not yet been signed.

**Warning**

NSEC3 Opt-Out feature brings benefit only to extremely large zones with lots of insecure delegations. Its use is counterproductive in all other cases as it decreases tamper-resistance of the zone and also decreases efficiency of resolver cache (see [RFC 8198](#)).

In other words, don't enable Opt-Out unless you are serving an equivalent of `com.` zone.

Because the NSEC3PARAM record does not keep track of whether opt-out is used, it is hard to check whether changes need to be made to the NSEC3 chain if the flag is changed. Similar to changing the NSEC3 salt, your best option is to change the value of `optout` together with another NSEC3 parameter, like `iterations`, and in a following step restore the `iterations` value.

For this recipe we assume the zone `example.com` has the following four entries (for this example, it is not relevant what record types these entries are):

- `ns1.example.com`
- `ftp.example.com`
- `www.example.com`
- `web.example.com`

And the zone `example.com` has five delegations to five subdomains, only one of which is signed and has a valid DS RRset:

- `aaa.example.com`, not signed
- `bbb.example.com`, signed
- `ccc.example.com`, not signed
- `ddd.example.com`, not signed
- `eee.example.com`, not signed

Before enabling NSEC3 opt-out, the zone `example.com` contains ten NSEC3 records; below is the list with the plain text name before the actual NSEC3 record:

- `aaa.example.com`: IFA1I3IE7EKCTPHM6R58URO3Q846I52M.example.com
- `bbb.example.com`: ROJUF3VJSJO6LQ2LC1DNSJ5GBAUJVPVHE.example.com
- `ccc.example.com`: 0VPUT696LUVDPDS5NIHSHBH9KLV20V5K.example.com
- `ddd.example.com`: UHPBD5U4HRGB84MLC2NQOVEFNAKJU0CA.example.com
- `eee.example.com`: NF7I61FA4C2UEKPMEDSOC25FE0UJIMKT.example.com
- `ftp.example.com`: 8P15KCUAT1RHCSN46HBQVPI5T532IN1.example.com
- `ns1.example.com`: GUFVRA2SFIO8RSFP7UO41E8AD1KR41FH.example.com
- `web.example.com`: CVQ4LA4ALPQIAO2H3N2RB6IR8UHM91E7.example.com
- `www.example.com`: MIFDNDT3NFF3OD53O7TLA1HRFF95JKUK.example.com
- `example.com`: ONIB9MGUB9H0RML3CDF5BGRJ59DKJHVK.example.com

We can enable NSEC3 opt-out with the following configuration, changing the `optout` configuration value from `no` to `yes`:

```
dnssec-policy "standard" {
    nsec3param iterations 0 optout yes salt-length 0;
};
```

After NSEC3 opt-out is enabled, the number of NSEC3 records is reduced. Notice that the unsigned delegations `aaa`, `ccc`, `ddd`, and `eee` no longer have corresponding NSEC3 records.

- `bbb.example.com`: ROJUF3VJSJO6LQ2LC1DNSJ5GBAUJVPVHE.example.com
- `ftp.example.com`: 8P15KCUAT1RHCSN46HBQVPI5T532IN1.example.com
- `ns1.example.com`: GUFVRA2SFIO8RSFP7UO41E8AD1KR41FH.example.com
- `web.example.com`: CVQ4LA4ALPQIAO2H3N2RB6IR8UHM91E7.example.com
- `www.example.com`: MIFDNDT3NFF3OD53O7TLA1HRFF95JKUK.example.com
- `example.com`: ONIB9MGUB9H0RML3CDF5BGRJ59DKJHVK.example.com

To undo NSEC3 opt-out, change the configuration again:

```
dnssec-policy "standard" {
    nsec3param iterations 0 optout no salt-length 0;
};
```

**Note**

NSEC3 hashes the plain text domain name, and we can compute our own hashes using the tool `nsec3hash`. For example, to compute the hashed name for `www.example.com` using the parameters we listed above, we can execute this command:

```
# nsec3hash - 1 0 www.example.com.
MIFDNDT3NFF3OD53O7TLA1HRFF95JKUK (salt=-, hash=1, iterations=0)
```

## 11.8.4 Reverting to Unsigned

This recipe describes how to revert from a signed zone (DNSSEC) back to an unsigned (DNS) zone.

Here is what `named.conf` looks like when it is signed:

```
zone "example.com" IN {
    type primary;
    file "db/example.com.db";
    dnssec-policy "default";
    inline-signing yes;
};
```

To indicate the reversion to unsigned, change the `dnssec-policy` line:

```
zone "example.com" IN {
    type primary;
    file "db/example.com.db";
    dnssec-policy "insecure";
    inline-signing yes;
};
```

Then use `rndc reload` to reload the zone.

The "insecure" policy is a built-in policy (like "default"). It makes sure the zone is still DNSSEC-maintained, to allow for a graceful transition to unsigned. It also publishes the CDS and CDNSKEY DELETE records automatically at the appropriate time.

If the parent zone allows management of DS records via CDS/CDNSKEY, as described in [RFC 8078](#), the DS record should be removed from the parent automatically.

Otherwise, DS records can be removed via the registrar. Below is an example showing how to remove DS records using the GoDaddy web-based interface:

1. After logging in, click the green "Launch" button next to the domain name you want to manage.
2. Scroll down to the "DS Records" section and click Manage.
3. A dialog appears, displaying all current keys. Use the far right-hand X button to remove each key.
4. Click Save.

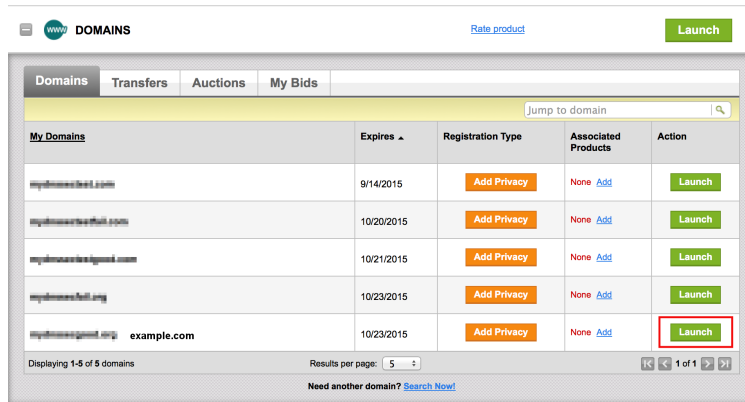

Fig. 16: Revert to Unsigned Step #1

### Domain Settings

**Auto-Renew** ⓘ Standard: On  
Extended: Off  
[Manage](#)

---

**Lock** ⓘ On  
[Manage](#)

---

**Nameservers** ⓘ  
[Redacted]  
Updated 10/24/2014  
[Manage](#)

---

**Forwarding** ⓘ Domain: Off  
[Manage](#)  
Subdomain: 0 subdomains forwarded  
[Manage](#)

---

**Premium DNS** ⓘ Expires: 10/21/2015  
[Manage](#)  
Secondary DNS: Off  
[Manage](#)  
DNSSEC: Unavailable  
[Manage](#)  
Vanity Nameservers: Off  
[Manage](#)

---

**DS Records** ⓘ 2 DS records created  
[Manage](#)

Fig. 17: Revert to Unsigned Step #2

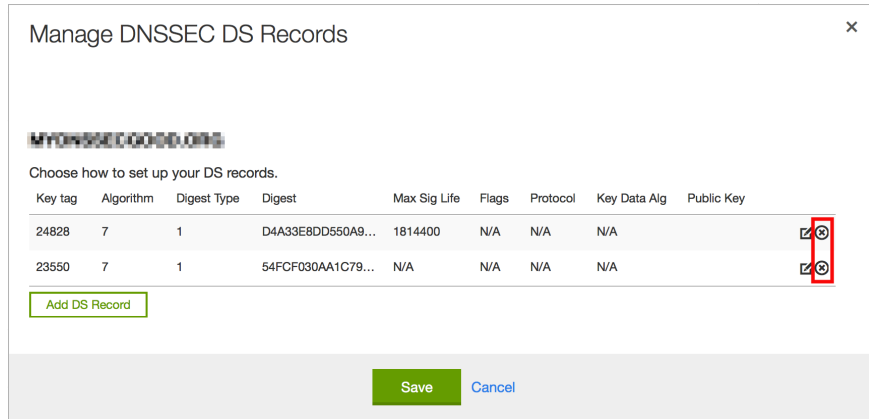

Fig. 18: Revert to Unsigned Step #3

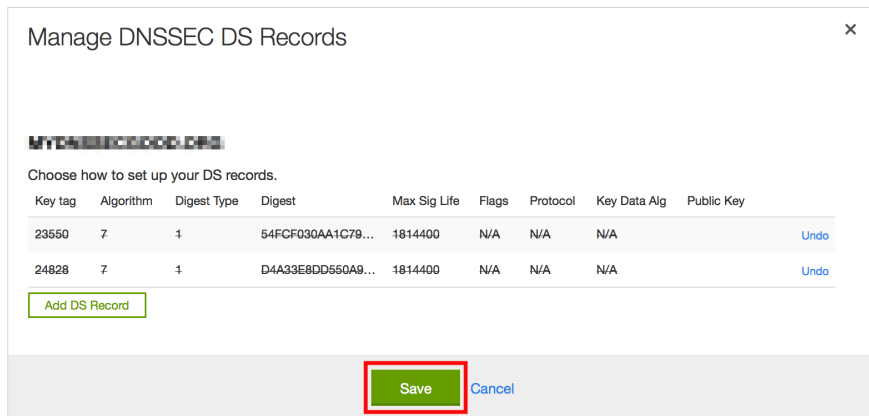

Fig. 19: Revert to Unsigned Step #4

When the DS records have been removed from the parent zone, use `rndc dnssec -checkds -key id withdrawn example.com` to tell `named` that the DS is removed, and the remaining DNSSEC records will be removed in a timely manner. Or, if parental agents are configured, the DNSSEC records will be automatically removed after BIND has seen that the parental agents no longer serve the DS RRset for this zone.

After a while, the zone is reverted back to the traditional, insecure DNS format. This can be verified by checking that all DNSKEY and RRSIG records have been removed from the zone.

The `dnssec-policy` line can then be removed from `named.conf` and the zone reloaded. The zone will no longer be subject to any DNSSEC maintenance.

## 11.9 Commonly Asked Questions

Below are some common questions and (hopefully) some answers that help.

### Do I need IPv6 to have DNSSEC?

No. DNSSEC can be deployed without IPv6.

### Does DNSSEC encrypt my DNS traffic, so others cannot eavesdrop on my DNS queries?

No. Although cryptographic keys and digital signatures are used in DNSSEC, they only provide authenticity and integrity, not privacy. Someone who sniffs network traffic can still see all the DNS queries and answers in plain text; DNSSEC just makes it very difficult for the eavesdropper to alter or spoof the DNS responses. For protection against eavesdropping, the preferred protocol is DNS-over-TLS. DNS-over-HTTPS can also do the job, but it is more complex.

### If I deploy DNS-over-TLS/HTTPS, can I skip deploying DNSSEC?

No. DNS-over-encrypted-transport stops eavesdroppers on a network, but it does not protect against cache poisoning and answer manipulation in other parts of the DNS resolution chain. In other words, these technologies offer protection only for records when they are in transit between two machines; any compromised server can still redirect traffic elsewhere (or simply eavesdrop). However, DNSSEC provides integrity and authenticity for DNS records, even when these records are stored in caches and on disks.

### Does DNSSEC protect the communication between my laptop and my name server?

Unfortunately, not at the moment. DNSSEC is designed to protect the communication between end clients (laptop) and name servers; however, there are few applications or stub resolver libraries as of mid-2020 that take advantage of this capability.

### Does DNSSEC secure zone transfers?

No. You should consider using TSIG to secure zone transfers among your name servers.

### Does DNSSEC protect my network from malicious websites?

DNSSEC makes it much more difficult for attackers to spoof DNS responses or perform cache poisoning. It cannot protect against users who visit a malicious website that an attacker owns and operates, or prevent users from mistyping a domain name; it will just become less likely that an attacker can hijack other domain names.

In other words, DNSSEC is designed to provide confidence that when a DNS response is received for `www.company.com` over port 53, it really came from Company's name servers and the answers are authentic. But that does not mean the web server a user visits over port 80 or port 443 is necessarily safe.

### If I enable DNSSEC validation, will it break DNS lookup, since most domain names do not yet use DNSSEC?

No, DNSSEC is backwards-compatible to "standard" DNS. A DNSSEC-enabled validating resolver can still look up all of these domain names as it always has under standard DNS.

There are four (4) categories of responses (see [RFC 4035](#)):

#### Secure

Domains that have DNSSEC deployed correctly.

#### Insecure

Domains that have yet to deploy DNSSEC.

**Bogus**

Domains that have deployed DNSSEC but have done it incorrectly.

**Indeterminate**

Domains for which it is not possible to determine whether these domains use DNSSEC.

A DNSSEC-enabled validating resolver still resolves *Secure* and *Insecure*; only *Bogus* and *Indeterminate* result in a SERVFAIL. As of mid-2022, roughly one-third of users worldwide are using DNSSEC validation on their recursive name servers. Google public DNS (8.8.8.8) also has enabled DNSSEC validation.

**Do I need to have special client software to use DNSSEC?**

No. DNSSEC only changes the communication behavior among DNS servers, not between a DNS server (validating resolver) and a client (stub resolver). With DNSSEC validation enabled on your recursive server, if a domain name does not pass the checks, an error message (typically SERVFAIL) is returned to clients; to most client software today, it appears that the DNS query has failed or that the domain name does not exist.

**Since DNSSEC uses public key cryptography, do I need Public Key Infrastructure (PKI) in order to use DNSSEC?**

No, DNSSEC does not depend on an existing PKI. Public keys are stored within the DNS hierarchy; the trustworthiness of each zone is guaranteed by its parent zone, all the way back to the root zone. A copy of the trust anchor for the root zone is distributed with BIND 9.

**Do I need to purchase SSL certificates from a Certificate Authority (CA) to use DNSSEC?**

No. With DNSSEC, you generate and publish your own keys, and sign your own data as well. There is no need to pay someone else to do it for you.

**My parent zone does not support DNSSEC; can I still sign my zone?**

Technically, yes, but you will not get the full benefit of DNSSEC, as other validating resolvers are not able to validate your zone data. Without the DS record(s) in your parent zone, other validating resolvers treat your zone as an insecure (traditional) zone, and no actual verification is carried out. To the rest of the world, your zone still appears to be insecure, and it will continue to be insecure until your parent zone can host the DS record(s) for you and tell the rest of the world that your zone is signed.

**Is DNSSEC the same thing as TSIG?**

No. TSIG is typically used between primary and secondary name servers to secure zone transfers, while DNSSEC secures DNS lookup by validating answers. Even if you enable DNSSEC, zone transfers are still not validated; to secure the communication between your primary and secondary name servers, consider setting up TSIG or similar secure channels.

**How are keys copied from primary to secondary server(s)?**

DNSSEC uses public cryptography, which results in two types of keys: public and private. The public keys are part of the zone data, stored as DNSKEY record types. Thus the public keys are synchronized from primary to secondary server(s) as part of the zone transfer. The private keys are not, and should not be, stored anywhere other than secured on the primary server. See *Key Storage* for more information on key storage options and considerations.

**Can I use the same key for multiple zones?**

Yes and no. Good security practice suggests that you should use unique key pairs for each zone, just as you should have different passwords for your email account, social media login, and online banking credentials. On a technical level, it is completely feasible to reuse a key, but multiple zones are at risk if one key pair is compromised. However, if you have hundreds or thousands of zones to administer, a single key pair for all might be less error-prone to manage. You may choose to use the same approach as with password management: use unique passwords for your bank accounts and shopping sites, but use a standard password for your not-very-important logins. First, categorize your zones: high-value zones (or zones that have specific key rollover requirements) get their own key pairs, while other, more "generic" zones can use a single key pair for easier management. Note that at present (mid-2020), fully automatic signing (using the *dnssec-policy* clause in your *named* configuration file) does not support reuse of keys except when the same zone appears in multiple views (see next question). To use the same key for multiple zones, sign your zones using semi-automatic signing. Each zone wishing to use the key should point to the same key directory.

**How do I sign the different instances of a zone that appears in multiple views?**

Add a *dnssec-policy* statement to each *zone* definition in the configuration file. To avoid problems when a single computer accesses different instances of the zone while information is still in its cache (e.g., a laptop moving from your office to a customer site), you should sign all instances with the same key. This means setting the same DNSSEC policy for all instances of the zone, and making sure that the key directory is the same for all instances of the zone.

**Will there be any problems if I change the DNSSEC policy for a zone?**

If you are using fully automatic signing, no. Just change the parameters in the *dnssec-policy* statement and reload the configuration file. *named* makes a smooth transition to the new policy, ensuring that your zone remains valid at all times.



## 12.1 arpaname - translate IP addresses to the corresponding ARPA names

### 12.1.1 Synopsis

**arpaname** {*ipaddress ...*}

### 12.1.2 Description

**arpaname** translates IP addresses (IPv4 and IPv6) to the corresponding IN-ADDR.ARPA or IP6.ARPA names.

### 12.1.3 See Also

BIND 9 Administrator Reference Manual.

## 12.2 ddns-confgen - TSIG key generation tool

### 12.2.1 Synopsis

**ddns-confgen** [-a algorithm] [-h] [-k keyname] [-q] [-s name] [-z zone]

### 12.2.2 Description

**ddns-confgen** is an utility that generates keys for use in TSIG signing. The resulting keys can be used, for example, to secure dynamic DNS updates to a zone, or for the *rndc* command channel.

The key name can specified using *-k* parameter and defaults to *ddns-key*. The generated key is accompanied by configuration text and instructions that can be used with *nsupdate* and *named* when setting up dynamic DNS, including an example *update-policy* statement. (This usage is similar to the *rndc-confgen* command for setting up command-channel security.)

Note that *named* itself can configure a local DDNS key for use with *nsupdate -l*; it does this when a zone is configured with *update-policy local*; **ddns-confgen** is only needed when a more elaborate configuration is required: for instance, if *nsupdate* is to be used from a remote system.

### 12.2.3 Options

**-a** algorithm

This option specifies the algorithm to use for the TSIG key. Available choices are: *hmac-md5*, *hmac-sha1*, *hmac-sha224*, *hmac-sha256*, *hmac-sha384*, and *hmac-sha512*. The default is *hmac-sha256*. Options are case-insensitive, and the "hmac-" prefix may be omitted.

**-h**

This option prints a short summary of options and arguments.

**-k** keyname

This option specifies the key name of the DDNS authentication key. The default is `ddns-key` when neither the `-s` nor `-z` option is specified; otherwise, the default is `ddns-key` as a separate label followed by the argument of the option, e.g., `ddns-key.example.com`. The key name must have the format of a valid domain name, consisting of letters, digits, hyphens, and periods.

**-q**

This option enables quiet mode, which prints only the key, with no explanatory text or usage examples. This is essentially identical to `tsig-keygen`.

**-s** name

This option generates a configuration example to allow dynamic updates of a single hostname. The example `named.conf` text shows how to set an update policy for the specified name using the "name" nametype. The default key name is `ddns-key.name`. Note that the "self" nametype cannot be used, since the name to be updated may differ from the key name. This option cannot be used with the `-z` option.

**-z** zone

This option generates a configuration example to allow dynamic updates of a zone. The example `named.conf` text shows how to set an update policy for the specified zone using the "zonesub" nametype, allowing updates to all subdomain names within that zone. This option cannot be used with the `-s` option.

## 12.2.4 See Also

`nsupdate(1)`, `named.conf(5)`, `named(8)`, BIND 9 Administrator Reference Manual.

## 12.3 delv - DNS lookup and validation utility

### 12.3.1 Synopsis

**delv** [@server] [ [-4] | [-6] ] [-a anchor-file] [-b address] [-c class] [-d level] [-i] [-m] [-p port#] [-q name] [-t type] [-x addr] [name] [type] [class] [queryopt...]

**delv** [-h]

**delv** [-v]

**delv** [queryopt...] [query...]

### 12.3.2 Description

**delv** is a tool for sending DNS queries and validating the results, using the same internal resolver and validator logic as `named`.

**delv** sends to a specified name server all queries needed to fetch and validate the requested data; this includes the original requested query, subsequent queries to follow CNAME or DNAME chains, queries for DNSKEY, and DS records to establish a chain of trust for DNSSEC validation. It does not perform iterative resolution, but simulates the behavior of a name server configured for DNSSEC validating and forwarding.

By default, responses are validated using the built-in DNSSEC trust anchor for the root zone ("."). Records returned by **delv** are either fully validated or were not signed. If validation fails, an explanation of the failure is included in the output; the validation process can be traced in detail. Because **delv** does not rely on an external server to carry out validation, it can be used to check the validity of DNS responses in environments where local name servers may not be trustworthy.

Unless it is told to query a specific name server, **delv** tries each of the servers listed in `/etc/resolv.conf`. If no usable server addresses are found, **delv** sends queries to the localhost addresses (127.0.0.1 for IPv4, ::1 for IPv6).

When no command-line arguments or options are given, **delv** performs an NS query for "." (the root zone).

### 12.3.3 Simple Usage

A typical invocation of **delv** looks like:

```
delv @server name type
```

where:

#### **server**

is the name or IP address of the name server to query. This can be an IPv4 address in dotted-decimal notation or an IPv6 address in colon-delimited notation. When the supplied `server` argument is a hostname, **delv** resolves that name before querying that name server (note, however, that this initial lookup is *not* validated by DNSSEC).

If no `server` argument is provided, **delv** consults `/etc/resolv.conf`; if an address is found there, it queries the name server at that address. If either of the `-4` or `-6` options is in use, then only addresses for the corresponding transport are tried. If no usable addresses are found, **delv** sends queries to the localhost addresses (127.0.0.1 for IPv4, ::1 for IPv6).

#### **name**

is the domain name to be looked up.

#### **type**

indicates what type of query is required - ANY, A, MX, etc. `type` can be any valid query type. If no `type` argument is supplied, **delv** performs a lookup for an A record.

### 12.3.4 Options

#### **-a** anchor-file

This option specifies a file from which to read DNSSEC trust anchors. The default is `/usr/local/etc/bind.keys`, which is included with BIND 9 and contains one or more trust anchors for the root zone ("").

Keys that do not match the root zone name are ignored. An alternate key name can be specified using the `+root` option.

**Note:** When reading the trust anchor file, **delv** treats `trust-anchors`, `initial-key`, and `static-key` identically. That is, for a managed key, it is the *initial* key that is trusted; **RFC 5011** key management is not supported. **delv** does not consult the managed-keys database maintained by `named`, which means that if either of the keys in `/usr/local/etc/bind.keys` is revoked and rolled over, `/usr/local/etc/bind.keys` must be updated to use DNSSEC validation in **delv**.

#### **-b** address

This option sets the source IP address of the query to `address`. This must be a valid address on one of the host's network interfaces, or `0.0.0.0`, or `::`. An optional source port may be specified by appending `#<port>`

#### **-c** class

This option sets the query class for the requested data. Currently, only class "IN" is supported in **delv** and any other value is ignored.

#### **-d** level

This option sets the systemwide debug level to `level`. The allowed range is from 0 to 99. The default is 0 (no debugging). Debugging traces from **delv** become more verbose as the debug level increases. See the `+mtrace`, `+rtrace`, and `+vtrace` options below for additional debugging details.

- h**  
This option displays the **delv** help usage output and exits.
- i**  
This option sets insecure mode, which disables internal DNSSEC validation. (Note, however, that this does not set the CD bit on upstream queries. If the server being queried is performing DNSSEC validation, then it does not return invalid data; this can cause **delv** to time out. When it is necessary to examine invalid data to debug a DNSSEC problem, use *dig +cd*.)
- m**  
This option enables memory usage debugging.
- p port#**  
This option specifies a destination port to use for queries, instead of the standard DNS port number 53. This option is used with a name server that has been configured to listen for queries on a non-standard port number.
- q name**  
This option sets the query name to *name*. While the query name can be specified without using the *-q* option, it is sometimes necessary to disambiguate names from types or classes (for example, when looking up the name "ns", which could be misinterpreted as the type NS, or "ch", which could be misinterpreted as class CH).
- t type**  
This option sets the query type to *type*, which can be any valid query type supported in BIND 9 except for zone transfer types AXFR and IXFR. As with *-q*, this is useful to distinguish query-name types or classes when they are ambiguous. It is sometimes necessary to disambiguate names from types.  
  
The default query type is "A", unless the *-x* option is supplied to indicate a reverse lookup, in which case it is "PTR".
- v**  
This option prints the **delv** version and exits.
- x addr**  
This option performs a reverse lookup, mapping an address to a name. *addr* is an IPv4 address in dotted-decimal notation, or a colon-delimited IPv6 address. When *-x* is used, there is no need to provide the *name* or *type* arguments; **delv** automatically performs a lookup for a name like *11.12.13.10.in-addr.arpa* and sets the query type to PTR. IPv6 addresses are looked up using nibble format under the IP6.ARPA domain.
- 4**  
This option forces **delv** to only use IPv4.
- 6**  
This option forces **delv** to only use IPv6.

### 12.3.5 Query Options

**delv** provides a number of query options which affect the way results are displayed, and in some cases the way lookups are performed.

Each query option is identified by a keyword preceded by a plus sign (+). Some keywords set or reset an option. These may be preceded by the string *no* to negate the meaning of that keyword. Other keywords assign values to options like the timeout interval. They have the form *+keyword=value*. The query options are:

**+cdflag, +nocdf**

This option controls whether to set the CD (checking disabled) bit in queries sent by **delv**. This may be useful when troubleshooting DNSSEC problems from behind a validating resolver. A validating resolver blocks invalid responses, making it difficult to retrieve them for analysis. Setting the CD flag on queries causes the resolver to return invalid responses, which **delv** can then validate internally and report the errors in detail.

**+class, +noclass**

This option controls whether to display the CLASS when printing a record. The default is to display the CLASS.

**+ttl, +nottl**

This option controls whether to display the TTL when printing a record. The default is to display the TTL.

**+rtrace, +nortrace**

This option toggles resolver fetch logging. This reports the name and type of each query sent by **delv** in the process of carrying out the resolution and validation process, including the original query and all subsequent queries to follow CNAMEs and to establish a chain of trust for DNSSEC validation.

This is equivalent to setting the debug level to 1 in the "resolver" logging category. Setting the systemwide debug level to 1 using the *-d* option produces the same output, but affects other logging categories as well.

**+mtrace, +nomtrace**

This option toggles message logging. This produces a detailed dump of the responses received by **delv** in the process of carrying out the resolution and validation process.

This is equivalent to setting the debug level to 10 for the "packets" module of the "resolver" logging category. Setting the systemwide debug level to 10 using the *-d* option produces the same output, but affects other logging categories as well.

**+vtrace, +novtrace**

This option toggles validation logging. This shows the internal process of the validator as it determines whether an answer is validly signed, unsigned, or invalid.

This is equivalent to setting the debug level to 3 for the "validator" module of the "dnssec" logging category. Setting the systemwide debug level to 3 using the *-d* option produces the same output, but affects other logging categories as well.

**+short, +noshort**

This option toggles between verbose and terse answers. The default is to print the answer in a verbose form.

**+comments, +nocomments**

This option toggles the display of comment lines in the output. The default is to print comments.

**+rrcomments, +norrcomments**

This option toggles the display of per-record comments in the output (for example, human-readable key information about DNSKEY records). The default is to print per-record comments.

**+crypto, +nocrypto**

This option toggles the display of cryptographic fields in DNSSEC records. The contents of these fields are unnecessary to debug most DNSSEC validation failures and removing them makes it easier to see the common failures. The default is to display the fields. When omitted, they are replaced by the string [omitted] or, in the DNSKEY case, the key ID is displayed as the replacement, e.g. [ key id = value ].

**+trust, +notrust**

This option controls whether to display the trust level when printing a record. The default is to display the trust level.

**+split [=W], +nosplit**

This option splits long hex- or base64-formatted fields in resource records into chunks of *W* characters (where *W* is rounded up to the nearest multiple of 4). *+nosplit* or *+split=0* causes fields not to be split at all. The default is 56 characters, or 44 characters when multiline mode is active.

**+all, +noall**

This option sets or clears the display options *+comments*, *+rrcomments*, and *+trust* as a group.

**+multiline, +nomultiline**

This option prints long records (such as RRSIG, DNSKEY, and SOA records) in a verbose multi-line format with human-readable comments. The default is to print each record on a single line, to facilitate machine parsing of the `delv` output.

**+dnssec, +nodnssec**

This option indicates whether to display RRSIG records in the `delv` output. The default is to do so. Note that (unlike in `dig`) this does *not* control whether to request DNSSEC records or to validate them. DNSSEC records are always requested, and validation always occurs unless suppressed by the use of `-i` or `+noroot`.

**+root [=ROOT], +noroot**

This option indicates whether to perform conventional DNSSEC validation, and if so, specifies the name of a trust anchor. The default is to validate using a trust anchor of "." (the root zone), for which there is a built-in key. If specifying a different trust anchor, then `-a` must be used to specify a file containing the key.

**+tcp, +notcp**

This option controls whether to use TCP when sending queries. The default is to use UDP unless a truncated response has been received.

**+unknownformat, +nunknownformat**

This option prints all RDATA in unknown RR-type presentation format ([RFC 3597](#)). The default is to print RDATA for known types in the type's presentation format.

**+yaml, +noyaml**

This option prints response data in YAML format.

### 12.3.6 Files

`/usr/local/etc/bind.keys`

`/etc/resolv.conf`

### 12.3.7 See Also

`dig(1)`, `named(8)`, [RFC 4034](#), [RFC 4035](#), [RFC 4431](#), [RFC 5074](#), [RFC 5155](#).

## 12.4 dig - DNS lookup utility

### 12.4.1 Synopsis

`dig` [`@server`] [`-b address`] [`-c class`] [`-f filename`] [`-k filename`] [`-m`] [`-p port#`] [`-q name`] [`-t type`] [`-v`] [`-x addr`] [`-y [hmac:]name:key`] [`[-4] | [-6]`] [`name`] [`type`] [`class`] [`queryopt...`]

`dig` [`-h`]

`dig` [`global-queryopt...`] [`query...`]

### 12.4.2 Description

`dig` is a flexible tool for interrogating DNS name servers. It performs DNS lookups and displays the answers that are returned from the name server(s) that were queried. Most DNS administrators use `dig` to troubleshoot DNS problems because of its flexibility, ease of use, and clarity of output. Other lookup tools tend to have less functionality than `dig`.

Although `dig` is normally used with command-line arguments, it also has a batch mode of operation for reading lookup requests from a file. A brief summary of its command-line arguments and options is printed when the `-h` option is given. The BIND 9 implementation of `dig` allows multiple lookups to be issued from the command line.

Unless it is told to query a specific name server, **dig** tries each of the servers listed in `/etc/resolv.conf`. If no usable server addresses are found, **dig** sends the query to the local host.

When no command-line arguments or options are given, **dig** performs an NS query for "." (the root).

It is possible to set per-user defaults for **dig** via `${HOME}/.digrc`. This file is read and any options in it are applied before the command-line arguments. The `-r` option disables this feature, for scripts that need predictable behavior.

The IN and CH class names overlap with the IN and CH top-level domain names. Either use the `-t` and `-c` options to specify the type and class, use the `-q` to specify the domain name, or use "IN." and "CH." when looking up these top-level domains.

### 12.4.3 Simple Usage

A typical invocation of **dig** looks like:

```
dig @server name type
```

where:

#### **server**

is the name or IP address of the name server to query. This can be an IPv4 address in dotted-decimal notation or an IPv6 address in colon-delimited notation. When the supplied `server` argument is a hostname, **dig** resolves that name before querying that name server.

If no `server` argument is provided, **dig** consults `/etc/resolv.conf`; if an address is found there, it queries the name server at that address. If either of the `-4` or `-6` options are in use, then only addresses for the corresponding transport are tried. If no usable addresses are found, **dig** sends the query to the local host. The reply from the name server that responds is displayed.

#### **name**

is the name of the resource record that is to be looked up.

#### **type**

indicates what type of query is required - ANY, A, MX, SIG, etc. `type` can be any valid query type. If no `type` argument is supplied, **dig** performs a lookup for an A record.

### 12.4.4 Options

#### **-4**

This option indicates that only IPv4 should be used.

#### **-6**

This option indicates that only IPv6 should be used.

#### **-b** address[#port]

This option sets the source IP address of the query. The `address` must be a valid address on one of the host's network interfaces, or "0.0.0.0" or ":::". An optional port may be specified by appending `#port`.

#### **-c** class

This option sets the query class. The default `class` is IN; other classes are HS for Hesiod records or CH for Chaosnet records.

#### **-f** file

This option sets batch mode, in which **dig** reads a list of lookup requests to process from the given `file`. Each line in the file should be organized in the same way it would be presented as a query to **dig** using the command-line interface.

**-h**

Print a usage summary.

**-k** *keyfile*

This option tells **dig** to sign queries using TSIG or SIG(0) using a key read from the given file. Key files can be generated using *tsig-keygen*. When using TSIG authentication with **dig**, the name server that is queried needs to know the key and algorithm that is being used. In BIND, this is done by providing appropriate *key* and *server* statements in *named.conf* for TSIG and by looking up the KEY record in zone data for SIG(0).

**-m**

This option enables memory usage debugging.

**-p** *port*

This option sends the query to a non-standard port on the server, instead of the default port 53. This option is used to test a name server that has been configured to listen for queries on a non-standard port number.

**-q** *name*

This option specifies the domain name to query. This is useful to distinguish the *name* from other arguments.

**-r**

This option indicates that options from `/${HOME}/.digrc` should not be read. This is useful for scripts that need predictable behavior.

**-t** *type*

This option indicates the resource record type to query, which can be any valid query type. If it is a resource record type supported in BIND 9, it can be given by the type mnemonic (such as *NS* or *AAAA*). The default query type is *A*, unless the **-x** option is supplied to indicate a reverse lookup. A zone transfer can be requested by specifying a type of *AXFR*. When an incremental zone transfer (*IXFR*) is required, set the *type* to *ixfr=N*. The incremental zone transfer contains all changes made to the zone since the serial number in the zone's *SOA* record was *N*.

All resource record types can be expressed as *TYPEnn*, where *nn* is the number of the type. If the resource record type is not supported in BIND 9, the result is displayed as described in [RFC 3597](#).

**-u**

This option indicates that print query times should be provided in microseconds instead of milliseconds.

**-v**

This option prints the version number and exits.

**-x** *addr*

This option sets simplified reverse lookups, for mapping addresses to names. The *addr* is an IPv4 address in dotted-decimal notation, or a colon-delimited IPv6 address. When the **-x** option is used, there is no need to provide the *name*, *class*, and *type* arguments. **dig** automatically performs a lookup for a name like `94.2.0.192.in-addr.arpa` and sets the query type and class to *PTR* and *IN* respectively. IPv6 addresses are looked up using nibble format under the *IP6.ARPA* domain.

**-y** [*hmac:*]*keyname:secret*

This option signs queries using TSIG with the given authentication key. *keyname* is the name of the key, and *secret* is the base64-encoded shared secret. *hmac* is the name of the key algorithm; valid choices are *hmac-md5*, *hmac-sha1*, *hmac-sha224*, *hmac-sha256*, *hmac-sha384*, or *hmac-sha512*. If *hmac* is not specified, the default is *hmac-md5*; if MD5 was disabled, the default is *hmac-sha256*.

**Note**

Only the `-k` option should be used, rather than the `-y` option, because with `-y` the shared secret is supplied as a command-line argument in clear text. This may be visible in the output from `ps1` or in a history file maintained by the user's shell.

## 12.4.5 Query Options

`dig` provides a number of query options which affect the way in which lookups are made and the results displayed. Some of these set or reset flag bits in the query header, some determine which sections of the answer get printed, and others determine the timeout and retry strategies.

Each query option is identified by a keyword preceded by a plus sign (+). Some keywords set or reset an option; these may be preceded by the string `no` to negate the meaning of that keyword. Other keywords assign values to options, like the timeout interval. They have the form `+keyword=value`. Keywords may be abbreviated, provided the abbreviation is unambiguous; for example, `+cd` is equivalent to `+cdflag`. Query options are order sensitive. The query options are:

### **+aaflag, +noaaflag**

This option is a synonym for `+aaonly, +noaaonly`.

### **+aaonly, +noaaonly**

This option sets the `aa` flag in the query.

### **+additional, +noadditional**

This option displays [or does not display] the additional section of a reply. The default is to display it.

### **+adflag, +noadflag**

This option sets [or does not set] the AD (authentic data) bit in the query. This requests the server to return whether all of the answer and authority sections have been validated as secure, according to the security policy of the server. `AD=1` indicates that all records have been validated as secure and the answer is not from a OPT-OUT range. `AD=0` indicates that some part of the answer was insecure or not validated. This bit is set by default.

### **+all, +noall**

This option sets or clears all display flags.

### **+answer, +noanswer**

This option displays [or does not display] the answer section of a reply. The default is to display it.

### **+authority, +noauthority**

This option displays [or does not display] the authority section of a reply. The default is to display it.

### **+badcookie, +nobadcookie**

This option retries the lookup with a new server cookie if a BADCOOKIE response is received.

### **+besteffort, +nobesteffort**

This option attempts to display the contents of messages which are malformed. The default is to not display malformed answers.

### **+bufsize [=B]**

This option sets the UDP message buffer size advertised using EDNS0 to `B` bytes. The maximum and minimum sizes of this buffer are 65535 and 0, respectively. `+bufsize` restores the default buffer size.

### **+cd, +cdflag, +nocdflag**

This option sets [or does not set] the CD (checking disabled) bit in the query. This requests the server to not perform DNSSEC validation of responses.

### **+class, +noclass**

This option displays [or does not display] the CLASS when printing the record.

**+cmd, +nocmd**

This option toggles the printing of the initial comment in the output, identifying the version of **dig** and the query options that have been applied. This option always has a global effect; it cannot be set globally and then overridden on a per-lookup basis. The default is to print this comment.

**+coflag, +co, +nocoflag, +noco**

This option sets [or does not set] the CO (Compact denial of existence Ok) EDNS bit in the query. If set, it tells servers that Compact Denial of Existence responses are acceptable when replying to queries. The default is `+nocoflag`.

**+comments, +nocomments**

This option toggles the display of some comment lines in the output, with information about the packet header and OPT pseudosection, and the names of the response section. The default is to print these comments.

Other types of comments in the output are not affected by this option, but can be controlled using other command-line switches. These include `+cmd`, `+question`, `+stats`, and `+rrcomments`.

**+cookie=####, +nocookie**

This option sends [or does not send] a COOKIE EDNS option, with an optional value. Replaying a COOKIE from a previous response allows the server to identify a previous client. The default is `+cookie`.

`+cookie` is also set when `+trace` is set to better emulate the default queries from a nameserver.

**+crypto, +nocrypto**

This option toggles the display of cryptographic fields in DNSSEC records. The contents of these fields are unnecessary for debugging most DNSSEC validation failures and removing them makes it easier to see the common failures. The default is to display the fields. When omitted, they are replaced by the string `[omitted]` or, in the DNSKEY case, the key ID is displayed as the replacement, e.g. `[ key id = value ]`.

**+defname, +nodefname**

This option, which is deprecated, is treated as a synonym for `+search`, `+nosearch`.

**+dns64prefix, +nodns64prefix**

Lookup IPV4ONLY.ARPA AAAA and print any DNS64 prefixes found.

**+dnssec, +do, +nodnssec, +nodo**

This option requests that DNSSEC records be sent by setting the DNSSEC OK (DO) bit in the OPT record in the additional section of the query.

**+domain=somename**

This option sets the search list to contain the single domain `somename`, as if specified in a `domain` directive in `/etc/resolv.conf`, and enables search list processing as if the `+search` option were given.

**+dscp=value**

This option formerly set the DSCP value used when sending a query. It is now obsolete, and has no effect.

**+edns [=#], +noedns**

This option specifies the EDNS version to query with. Valid values are 0 to 255. Setting the EDNS version causes an EDNS query to be sent. `+noedns` clears the remembered EDNS version. EDNS is set to 0 by default.

**+ednsflags [=#], +noednsflags**

This option sets the must-be-zero EDNS flags bits (Z bits) to the specified value. Decimal, hex, and octal encodings are accepted. Setting a named flag (e.g. DO, CO) is silently ignored. By default, no Z bits are set.

**+ednsnegotiation, +noednsnegotiation**

This option enables/disables EDNS version negotiation. By default, EDNS version negotiation is enabled.

**+ednsopt** [=code[:value]], **+noednsopt**

This option specifies the EDNS option with code point `code` and an optional payload of `value` as a hexadecimal string. `code` can be either an EDNS option name (for example, `NSID` or `ECS`) or an arbitrary numeric value. `+noednsopt` clears the EDNS options to be sent.

**+expire**, **+noexpire**

This option sends an EDNS Expire option.

**+fail**, **+nofail**

This option indicates that *named* should try [or not try] the next server if a `SERVFAIL` is received. The default is to not try the next server, which is the reverse of normal stub resolver behavior.

**+fuzztime** [=value], **+nofuzztime**

This option allows the signing time to be specified when generating signed messages. If a value is specified it is the seconds since 00:00:00 January 1, 1970 UTC ignoring leap seconds. If no value is specified 1646972129 (Fri 11 Mar 2022 04:15:29 UTC) is used. The default is `+nofuzztime` and the current time is used.

**+header-only**, **+noheader-only**

This option sends a query with a DNS header without a question section. The default is to add a question section. The query type and query name are ignored when this is set.

**+https** [=value], **+nohttps**

This option indicates whether to use DNS over HTTPS (DoH) when querying name servers. When this option is in use, the port number defaults to 443. The HTTP POST request mode is used when sending the query.

If `value` is specified, it will be used as the HTTP endpoint in the query URI; the default is `/dns-query`. So, for example, `dig @example.com +https` will use the URI `https://example.com/dns-query`.

**+https-get** [=value], **+nohttps-get**

Similar to `+https`, except that the HTTP GET request mode is used when sending the query.

**+https-post** [=value], **+nohttps-post**

Same as `+https`.

**+http-plain** [=value], **+nohttp-plain**

Similar to `+https`, except that HTTP queries will be sent over a non-encrypted channel. When this option is in use, the port number defaults to 80 and the HTTP request mode is POST.

**+http-plain-get** [=value], **+nohttp-plain-get**

Similar to `+http-plain`, except that the HTTP request mode is GET.

**+http-plain-post** [=value], **+nohttp-plain-post**

Same as `+http-plain`.

**+identify**, **+noidentify**

This option shows [or does not show] the IP address and port number that supplied the answer, when the `+short` option is enabled. If short form answers are requested, the default is not to show the source address and port number of the server that provided the answer.

**+idnin**, **+noidnin**

This option processes [or does not process] IDN domain names on input. This requires `IDN_SUPPORT` to have been enabled at compile time.

The default is to process IDN input when standard output is a tty. The IDN processing on input is disabled when `dig` output is redirected to files, pipes, and other non-tty file descriptors.

**+idnout, +noidnout**

This option converts [or does not convert] puny code on output. This requires `IDN_SUPPORT` to have been enabled at compile time.

The default is to process puny code on output when standard output is a tty. The puny code processing on output is disabled when `dig` output is redirected to files, pipes, and other non-tty file descriptors.

**+ignore, +noignore**

This option ignores [or does not ignore] truncation in UDP responses instead of retrying with TCP. By default, TCP retries are performed.

**+keepalive, +nokeepalive**

This option sends [or does not send] an EDNS Keepalive option.

**+keepopen, +nokeepopen**

This option keeps [or does not keep] the TCP socket open between queries, and reuses it rather than creating a new TCP socket for each lookup. The default is `+nokeepopen`.

**+multiline, +nomultiline**

This option prints [or does not print] records, like the SOA records, in a verbose multi-line format with human-readable comments. The default is to print each record on a single line to facilitate machine parsing of the `dig` output.

**+ndots=D**

This option sets the number of dots (D) that must appear in `name` for it to be considered absolute. The default value is that defined using the `ndots` statement in `/etc/resolv.conf`, or 1 if no `ndots` statement is present. Names with fewer dots are interpreted as relative names, and are searched for in the domains listed in the `search` or `domain` directive in `/etc/resolv.conf` if `+search` is set.

**+nsid, +nonsid**

When enabled, this option includes an EDNS name server ID request when sending a query.

**+nssearch, +nonssearch**

When this option is set, `dig` attempts to find the authoritative name servers for the zone containing the name being looked up, and display the SOA record that each name server has for the zone. Addresses of servers that did not respond are also printed.

**+onesoa, +noonesoa**

When enabled, this option prints only one (starting) SOA record when performing an AXFR. The default is to print both the starting and ending SOA records.

**+opcode=value, +noopcode**

When enabled, this option sets (restores) the DNS message opcode to the specified value. The default value is QUERY (0).

**+padding=value**

This option pads the size of the query packet using the EDNS Padding option to blocks of `value` bytes. For example, `+padding=32` causes a 48-byte query to be padded to 64 bytes. The default block size is 0, which disables padding; the maximum is 512. Values are ordinarily expected to be powers of two, such as 128; however, this is not mandatory. Responses to padded queries may also be padded, but only if the query uses TCP or DNS COOKIE.

**+qid=value**

This option specifies the query ID to use when sending queries.

**+qr, +noqr**

This option toggles the display of the query message as it is sent. By default, the query is not printed.

**+question, +noquestion**

This option toggles the display of the question section of a query when an answer is returned. The default is to print the question section as a comment.

**+raflag, +noraflag**

This option sets [or does not set] the RA (Recursion Available) bit in the query. The default is `+noraflag`. This bit is ignored by the server for QUERY.

**+rdflag, +nordflag**

This option is a synonym for `+recurse, +norecurse`.

**+recurse, +norecurse**

This option toggles the setting of the RD (recursion desired) bit in the query. This bit is set by default, which means **dig** normally sends recursive queries. Recursion is automatically disabled when the `+nssearch` or `+trace` query option is used.

**+retry=T**

This option sets the number of times to retry UDP and TCP queries to server to `T` instead of the default, 2. Unlike `+tries`, this does not include the initial query.

**+rrcomments, +norrcomments**

This option toggles the display of per-record comments in the output (for example, human-readable key information about DNSKEY records). The default is not to print record comments unless multiline mode is active.

**+search, +nosearch**

This option uses [or does not use] the search list defined by the searchlist or domain directive in `resolv.conf`, if any. The search list is not used by default.

`ndots` from `resolv.conf` (default 1), which may be overridden by `+ndots`, determines whether the name is treated as relative and hence whether a search is eventually performed.

**+short, +noshort**

This option toggles whether a terse answer is provided. The default is to print the answer in a verbose form. This option always has a global effect; it cannot be set globally and then overridden on a per-lookup basis.

**+showbadcookie, +noshowbadcookie**

This option toggles whether to show the message containing the BADCOOKIE rcode before retrying the request or not. The default is to not show the messages.

**+showsearch, +noshowsearch**

This option performs [or does not perform] a search showing intermediate results.

**+sigchase, +nosigchase**

This feature is now obsolete and has been removed; use `delv` instead.

**+split=W**

This option splits long hex- or base64-formatted fields in resource records into chunks of `w` characters (where `w` is rounded up to the nearest multiple of 4). `+nosplit` or `+split=0` causes fields not to be split at all. The default is 56 characters, or 44 characters when multiline mode is active.

**+stats, +nostats**

This option toggles the printing of statistics: when the query was made, the size of the reply, etc. The default behavior is to print the query statistics as a comment after each lookup.

**+subnet=addr[/prefix-length], +nosubnet**

This option sends [or does not send] an EDNS CLIENT-SUBNET option with the specified IP address or network prefix.

`dig +subnet=0.0.0.0/0`, or simply `dig +subnet=0` for short, sends an EDNS CLIENT-SUBNET option with an empty address and a source prefix-length of zero, which signals a resolver that the client's address information must *not* be used when resolving this query.

**+tcflag, +notcflag**

This option sets [or does not set] the TC (TrunCation) bit in the query. The default is `+notcflag`. This bit is ignored by the server for QUERY.

**+tcp, +notcp**

This option indicates whether to use TCP when querying name servers. The default behavior is to use UDP unless a type `any` or `ixfr=N` query is requested, in which case the default is TCP. AXFR queries always use TCP. To prevent retry over TCP when TC=1 is returned from a UDP query, use `+ignore`.

**+timeout=T**

This option sets the timeout for a query to `T` seconds. The default timeout is 5 seconds. An attempt to set `T` to less than 1 is silently set to 1.

**+tls, +notls**

This option indicates whether to use DNS over TLS (DoT) when querying name servers. When this option is in use, the port number defaults to 853.

**+tls-ca[=file-name], +notls-ca**

This option enables remote server TLS certificate validation for DNS transports, relying on TLS. Certificate authorities certificates are loaded from the specified PEM file (`file-name`). If the file is not specified, the default certificates from the global certificates store are used.

**+tls-certfile=file-name, +tls-keyfile=file-name, +notls-certfile, +notls-keyfile**

These options set the state of certificate-based client authentication for DNS transports, relying on TLS. Both certificate chain file and private key file are expected to be in PEM format. Both options must be specified at the same time.

**+tls-hostname=hostname, +notls-hostname**

This option makes `dig` use the provided hostname during remote server TLS certificate verification. Otherwise, the DNS server name is used. This option has no effect if `+tls-ca` is not specified.

**+topdown, +notopdown**

This feature is related to `dig +sigchase`, which is obsolete and has been removed. Use `delv` instead.

**+trace, +notrace**

This option toggles tracing of the delegation path from the root name servers for the name being looked up. Tracing is disabled by default. When tracing is enabled, `dig` makes iterative queries to resolve the name being looked up. It follows referrals from the root servers, showing the answer from each server that was used to resolve the lookup.

If `@server` is also specified, it affects only the initial query for the root zone name servers.

`+dnssec` is also set when `+trace` is set, to better emulate the default queries from a name server.

**+tries=T**

This option sets the number of times to try UDP and TCP queries to server to `T` instead of the default, 3. If `T` is less than or equal to zero, the number of tries is silently rounded up to 1.

**+trusted-key=####**

This option formerly specified trusted keys for use with `dig +sigchase`. This feature is now obsolete and has been removed; use `delv` instead.

**+ttlid, +nottlid**

This option displays [or does not display] the TTL when printing the record.

**+ttlunits, +notttlunits**

This option displays [or does not display] the TTL in friendly human-readable time units of *s*, *m*, *h*, *d*, and *w*, representing seconds, minutes, hours, days, and weeks. This implies *+ttlid*.

**+unknownformat, +nunknownformat**

This option prints all RDATA in unknown RR type presentation format (RFC 3597). The default is to print RDATA for known types in the type's presentation format.

**+vc, +novc**

This option uses [or does not use] TCP when querying name servers. This alternate syntax to *+tcp* is provided for backwards compatibility. The *vc* stands for "virtual circuit."

**+yaml, +noyaml**

When enabled, this option prints the responses (and, if *+qr* is in use, also the outgoing queries) in a detailed YAML format.

**+zflag, +nozflag**

This option sets [or does not set] the last unassigned DNS header flag in a DNS query. This flag is off by default.

## 12.4.6 Multiple Queries

The BIND 9 implementation of **dig** supports specifying multiple queries on the command line (in addition to supporting the *-f* batch file option). Each of those queries can be supplied with its own set of flags, options, and query options.

In this case, each *query* argument represents an individual query in the command-line syntax described above. Each consists of any of the standard options and flags, the name to be looked up, an optional query type and class, and any query options that should be applied to that query.

A global set of query options, which should be applied to all queries, can also be supplied. These global query options must precede the first tuple of name, class, type, options, flags, and query options supplied on the command line. Any global query options (except *+cmd* and *+short* options) can be overridden by a query-specific set of query options. For example:

```
dig +qr www.isc.org any -x 127.0.0.1 isc.org ns +noqr
```

shows how **dig** can be used from the command line to make three lookups: an ANY query for *www.isc.org*, a reverse lookup of *127.0.0.1*, and a query for the NS records of *isc.org*. A global query option of *+qr* is applied, so that **dig** shows the initial query it made for each lookup. The final query has a local query option of *+noqr* which means that **dig** does not print the initial query when it looks up the NS records for *isc.org*.

## 12.4.7 IDN Support

If **dig** has been built with IDN (internationalized domain name) support, it can accept and display non-ASCII domain names. **dig** appropriately converts character encoding of a domain name before sending a request to a DNS server or displaying a reply from the server. To turn off IDN support, use the parameters *+idnin* and *+idnout*, or define the `IDN_DISABLE` environment variable.

## 12.4.8 Return Codes

**dig** return codes are:

- 0  
DNS response received, including NXDOMAIN status
- 1  
Usage error

- 8        Couldn't open batch file
- 9        No reply from server
- 10       Internal error

### 12.4.9 Files

`/etc/resolv.conf`  
`${HOME}/.digrc`

### 12.4.10 See Also

*delv(1)*, *host(1)*, *named(8)*, *dnssec-keygen(8)*, [RFC 1035](#).

### 12.4.11 Bugs

There are probably too many query options.

## 12.5 dnssec-cds - change DS records for a child zone based on CDS/CDNSKEY

### 12.5.1 Synopsis

**dnssec-cds** [-a alg...] [-c class] [-D] {-d dsset-file} {-f child-file} [-i\*\*[extension]] [-s\*\* start-time] [-T ttl] [-u] [-v level] [-V] {domain}

### 12.5.2 Description

The **dnssec-cds** command changes DS records at a delegation point based on CDS or CDNSKEY records published in the child zone. If both CDS and CDNSKEY records are present in the child zone, the CDS is preferred. This enables a child zone to inform its parent of upcoming changes to its key-signing keys (KSKs); by polling periodically with **dnssec-cds**, the parent can keep the DS records up-to-date and enable automatic rolling of KSKs.

Two input files are required. The `-f child-file` option specifies a file containing the child's CDS and/or CDNSKEY records, plus RRSIG and DNSKEY records so that they can be authenticated. The `-d path` option specifies the location of a file containing the current DS records. For example, this could be a `dsset-` file generated by *dnssec-signzone*, or the output of *dnssec-dsfromkey*, or the output of a previous run of **dnssec-cds**.

The **dnssec-cds** command uses special DNSSEC validation logic specified by [RFC 7344](#). It requires that the CDS and/or CDNSKEY records be validly signed by a key represented in the existing DS records. This is typically the pre-existing KSK.

For protection against replay attacks, the signatures on the child records must not be older than they were on a previous run of **dnssec-cds**. Their age is obtained from the modification time of the `dsset-` file, or from the `-s` option.

To protect against breaking the delegation, **dnssec-cds** ensures that the DNSKEY RRset can be verified by every key algorithm in the new DS RRset, and that the same set of keys are covered by every DS digest type.

By default, replacement DS records are written to the standard output; with the `-i` option the input file is overwritten in place. The replacement DS records are the same as the existing records, when no change is required. The output can be empty if the CDS/CDNSKEY records specify that the child zone wants to be insecure.

**Warning**

Be careful not to delete the DS records when `dnssec-cds` fails!

Alternatively, `:option`dnssec-cds -u`` writes an `nsupdate` script to the standard output. The `-u` and `-i` options can be used together to maintain a `dsset-` file as well as emit an `nsupdate` script.

### 12.5.3 Options

#### `-a` algorithm

When converting CDS records to DS records, this option specifies the acceptable digest algorithms. This option can be repeated, so that multiple digest types are allowed. If none of the CDS records use an acceptable digest type, `dnssec-cds` will try to use CDNSKEY records instead; if there are no CDNSKEY records, it reports an error.

When converting CDNSKEY records to DS records, this option specifies the digest algorithm to use. It can be repeated, so that multiple DS records are created for each CDNSKEY records.

The algorithm must be one of SHA-1, SHA-256, or SHA-384. These values are case-insensitive, and the hyphen may be omitted. If no algorithm is specified, the default is SHA-256 only.

#### `-c` class

This option specifies the DNS class of the zones.

#### `-D`

This option generates DS records from CDNSKEY records if both CDS and CDNSKEY records are present in the child zone. By default CDS records are preferred.

#### `-d` path

This specifies the location of the parent DS records. The path can be the name of a file containing the DS records; if it is a directory, `dnssec-cds` looks for a `dsset-` file for the domain inside the directory.

To protect against replay attacks, child records are rejected if they were signed earlier than the modification time of the `dsset-` file. This can be adjusted with the `-s` option.

#### `-f` child-file

This option specifies the file containing the child's CDS and/or CDNSKEY records, plus its DNSKEY records and the covering RRSIG records, so that they can be authenticated.

The examples below describe how to generate this file.

#### `-i` extension

This option updates the `dsset-` file in place, instead of writing DS records to the standard output.

There must be no space between the `-i` and the extension. If no extension is provided, the old `dsset-` is discarded. If an extension is present, a backup of the old `dsset-` file is kept with the extension appended to its filename.

To protect against replay attacks, the modification time of the `dsset-` file is set to match the signature inception time of the child records, provided that it is later than the file's current modification time.

#### `-s` start-time

This option specifies the date and time after which RRSIG records become acceptable. This can be either an absolute or a relative time. An absolute start time is indicated by a number in YYYYMMDDHHMMSS notation; 20170827133700 denotes 13:37:00 UTC on August 27th, 2017. A time relative to the `dsset-` file is indicated with `-N`, which is N seconds before the file modification time. A time relative to the current time is indicated with `now+N`.

If no start-time is specified, the modification time of the `dsset-` file is used.

**-T** *t**ttl*

This option specifies a TTL to be used for new DS records. If not specified, the default is the TTL of the old DS records. If they had no explicit TTL, the new DS records also have no explicit TTL.

**-u**

This option writes an *nsupdate* script to the standard output, instead of printing the new DS records. The output is empty if no change is needed.

Note: The TTL of new records needs to be specified: it can be done in the original *dsset-* file, with the *-T* option, or using the *nsupdate ttl* command.

**-v**

This option prints version information.

**-v** *level*

This option sets the debugging level. Level 1 is intended to be usefully verbose for general users; higher levels are intended for developers.

**domain**

This indicates the name of the delegation point/child zone apex.

## 12.5.4 Exit Status

The **dnssec-cds** command exits 0 on success, or non-zero if an error occurred.

If successful, the DS records may or may not need to be changed.

## 12.5.5 Examples

Before running *dnssec-signzone*, ensure that the delegations are up-to-date by running **dnssec-cds** on every *dsset-* file.

To fetch the child records required by **dnssec-cds**, invoke *dig* as in the script below. It is acceptable if the *dig* fails, since **dnssec-cds** performs all the necessary checking.

```
for f in dsset-*
do
  d=${f#dsset-}
  dig +dnssec +noall +answer $d DNSKEY $d CDNSKEY $d CDS |
  dnssec-cds -i -f /dev/stdin -d $f $d
done
```

When the parent zone is automatically signed by *named*, **dnssec-cds** can be used with *nsupdate* to maintain a delegation as follows. The *dsset-* file allows the script to avoid having to fetch and validate the parent DS records, and it maintains the replay attack protection time.

```
dig +dnssec +noall +answer $d DNSKEY $d CDNSKEY $d CDS |
dnssec-cds -u -i -f /dev/stdin -d $f $d |
nsupdate -l
```

## 12.5.6 See Also

*dig(1)*, *dnssec-settime(8)*, *dnssec-signzone(8)*, *nsupdate(1)*, BIND 9 Administrator Reference Manual, RFC 7344.

## 12.6 dnssec-dsfromkey - DNSSEC DS RR generation tool

### 12.6.1 Synopsis

```
dnssec-dsfromkey [ -1 | -2 | -a alg ] [ -C ] [-T TTL] [-v level] [-K directory] {keyfile}
dnssec-dsfromkey [ -1 | -2 | -a alg ] [ -C ] [-T TTL] [-v level] [-c class] [-A] {-f file} [dnsname]
dnssec-dsfromkey [ -1 | -2 | -a alg ] [ -C ] [-T TTL] [-v level] [-c class] [-K directory] {-s} {dnsname}
dnssec-dsfromkey [ -h | -V ]
```

### 12.6.2 Description

The `dnssec-dsfromkey` command outputs DS (Delegation Signer) resource records (RRs), or CDS (Child DS) RRs with the `-C` option.

By default, only KSKs are converted (keys with flags = 257). The `-A` option includes ZSKs (flags = 256). Revoked keys are never included.

The input keys can be specified in a number of ways:

By default, `dnssec-dsfromkey` reads a key file named in the format `Knnnn.+aaa+iiii.key`, as generated by `dnssec-keygen`.

With the `-f file` option, `dnssec-dsfromkey` reads keys from a zone file or partial zone file (which can contain just the DNSKEY records).

With the `-s` option, `dnssec-dsfromkey` reads a `keyset-` file, as generated by `dnssec-keygen -C`.

### 12.6.3 Options

`-1`

This option is an abbreviation for `-a SHA1`. This digest is deprecated.

`-2`

This option is an abbreviation for `-a SHA-256`.

`-a algorithm`

This option specifies a digest algorithm to use when converting DNSKEY records to DS records. This option can be repeated, so that multiple DS records are created for each DNSKEY record.

The algorithm must be one of SHA-1 (deprecated), SHA-256, or SHA-384. These values are case-insensitive, and the hyphen may be omitted. If no algorithm is specified, the default is SHA-256.

`-A`

This option indicates that ZSKs are to be included when generating DS records. Without this option, only keys which have the KSK flag set are converted to DS records and printed. This option is only useful in `-f` zone file mode.

`-c class`

This option specifies the DNS class; the default is IN. This option is only useful in `-s` keyset or `-f` zone file mode.

`-C`

This option generates CDS records rather than DS records.

`-f file`

This option sets zone file mode, in which the final `dnsname` argument of `dnssec-dsfromkey` is the DNS domain name of a zone whose master file can be read from `file`. If the zone name is the same as `file`, then it may be omitted.

If `file` is `-`, then the zone data is read from the standard input. This makes it possible to use the output of the `dig` command as input, as in:

```
dig dnskey example.com | dnssec-dsfromkey -f - example.com
```

**-h**

This option prints usage information.

**-K** *directory*

This option tells BIND 9 to look for key files or `keyset-` files in `directory`.

**-s**

This option enables keyset mode, in which the final `dnsname` argument from `dnssec-dsfromkey` is the DNS domain name used to locate a `keyset-` file.

**-T** *TTL*

This option specifies the TTL of the DS records. By default the TTL is omitted.

**-v** *level*

This option sets the debugging level.

**-V**

This option prints version information.

## 12.6.4 Example

To build the SHA-256 DS RR from the `Kexample.com.+003+26160` keyfile, issue the following command:

```
dnssec-dsfromkey -2 Kexample.com.+003+26160
```

The command returns something similar to:

```
example.com. IN DS 26160 5 2 3A1EADA7A74B8D0BA86726B0C227AA85AB8BBD2B2004F41A868A54F0C5EA0B94
```

## 12.6.5 Files

The keyfile can be designated by the key identification `Knnnn.+aaa+iiii` or the full file name `Knnnn.+aaa+iiii.key`, as generated by `dnssec-keygen`.

The keyset file name is built from the `directory`, the string `keyset-`, and the `dnsname`.

## 12.6.6 Caveat

A keyfile error may return "file not found," even if the file exists.

## 12.6.7 See Also

`dnssec-keygen(8)`, `dnssec-signzone(8)`, BIND 9 Administrator Reference Manual, [RFC 3658](#) (DS RRs), [RFC 4509](#) (SHA-256 for DS RRs), [RFC 6605](#) (SHA-384 for DS RRs), [RFC 7344](#) (CDS and CDNSKEY RRs).

# 12.7 dnssec-importkey - import DNSKEY records from external systems so they can be managed

## 12.7.1 Synopsis

```
dnssec-importkey [-K directory] [-L ttl] [-P date/offset] [-P sync date/offset] [-D date/offset] [-D sync date/offset] [-h] [-v level] [-V] {keyfile}
```

**dnssec-importkey** **-f** filename} **-K** directory] **-L** ttl] **-P** date/offset] **-P** sync date/offset] **-D** date/offset] **-D** sync date/offset] **-h**] **-v** level] **-V**] [dnsname]

## 12.7.2 Description

**dnssec-importkey** reads a public DNSKEY record and generates a pair of .key/.private files. The DNSKEY record may be read from an existing .key file, in which case a corresponding .private file is generated, or it may be read from any other file or from the standard input, in which case both .key and .private files are generated.

The newly created .private file does *not* contain private key data, and cannot be used for signing. However, having a .private file makes it possible to set publication (*-P*) and deletion (*-D*) times for the key, which means the public key can be added to and removed from the DNSKEY RRset on schedule even if the true private key is stored offline.

When using `dnssec-policy`, do not use **dnssec-importkey** to import key files that cannot be used for signing. In this case, simply publish the imported DNSKEY record in the zone, and make sure that the files are outside the configured `key-directory`.

## 12.7.3 Options

**-f** filename

This option indicates the zone file mode. Instead of a public keyfile name, the argument is the DNS domain name of a zone master file, which can be read from `filename`. If the domain name is the same as `filename`, then it may be omitted.

If `filename` is set to "-", then the zone data is read from the standard input.

**-K** directory

This option sets the directory in which the key files are to reside.

**-L** ttl

This option sets the default TTL to use for this key when it is converted into a DNSKEY RR. This is the TTL used when the key is imported into a zone, unless there was already a DNSKEY RRset in place, in which case the existing TTL takes precedence. Setting the default TTL to 0 or `none` removes it from the key.

**-h**

This option emits a usage message and exits.

**-v** level

This option sets the debugging level.

**-V**

This option prints version information.

## 12.7.4 Timing Options

Dates can be expressed in the format `YYYYMMDD` or `YYYYMMDDHHMMSS`. (which is the format used inside key files), or 'Day Mon DD HH:MM:SS YYYY' (as printed by `dnssec-settime -p`), or UNIX epoch time (as printed by `dnssec-settime -up`), or the literal `now`.

The argument can be followed by `+` or `-` and an offset from the given time. The literal `now` can be omitted before an offset. The offset can be followed by one of the suffixes `y`, `mo`, `w`, `d`, `h`, or `mi`, so that it is computed in years (defined as 365 24-hour days, ignoring leap years), months (defined as 30 24-hour days), weeks, days, hours, or minutes, respectively. Without a suffix, the offset is computed in seconds.

To explicitly prevent a date from being set, use `none`, `never`, or `unset`.

All these formats are case-insensitive.

**-P** *date/offset*

This option sets the date on which a key is to be published to the zone. After that date, the key is included in the zone but is not used to sign it.

**sync** *date/offset*

This option sets the date on which CDS and CDNSKEY records that match this key are to be published to the zone.

**-D** *date/offset*

This option sets the date on which the key is to be deleted. After that date, the key is no longer included in the zone. (However, it may remain in the key repository.)

**sync** *date/offset*

This option sets the date on which the CDS and CDNSKEY records that match this key are to be deleted.

## 12.7.5 Files

A keyfile can be designed by the key identification `Knnnn.+aaa+iiii` or the full file name `Knnnn.+aaa+iiii.key`, as generated by `dnssec-keygen`.

## 12.7.6 See Also

`dnssec-keygen(8)`, `dnssec-signzone(8)`, BIND 9 Administrator Reference Manual, [RFC 5011](#).

# 12.8 dnssec-keyfromlabel - DNSSEC key generation tool

## 12.8.1 Synopsis

```
dnssec-keyfromlabel {-l label} [-3] [-a algorithm] [-A date/offset] [-c class] [-D date/offset] [-D sync date/offset]
[-E engine] [-f flag] [-G] [-I date/offset] [-i interval] [-k] [-K directory] [-L ttl] [-n nametype] [-P date/offset] [-P sync
date/offset] [-p protocol] [-R date/offset] [-S key] [-t type] [-v level] [-V] [-y {name}]
```

## 12.8.2 Description

`dnssec-keyfromlabel` generates a pair of key files that reference a key object stored in a cryptographic hardware service module (HSM). The private key file can be used for DNSSEC signing of zone data as if it were a conventional signing key created by `dnssec-keygen`, but the key material is stored within the HSM and the actual signing takes place there.

The `name` of the key is specified on the command line. This must match the name of the zone for which the key is being generated.

## 12.8.3 Options

**-a** *algorithm*

This option selects the cryptographic algorithm. The value of `algorithm` must be one of RSASHA1 (deprecated), NSEC3RSASHA1 (deprecated), RSASHA256, RSASHA512, ECDSAP256SHA256, ECDSAP384SHA384, ED25519, or ED448.

These values are case-insensitive. In some cases, abbreviations are supported, such as ECDSA256 for ECDSAP256SHA256 and ECDSA384 for ECDSAP384SHA384. If RSASHA1 (deprecated) is specified along with the `-3` option, then NSEC3RSASHA1 (deprecated) is used instead.

This option is mandatory except when using the `-s` option, which copies the algorithm from the predecessor key.

Changed in version 9.12.0: The default value RSASHA1 (deprecated) for newly generated keys was removed.

- 3** This option uses an NSEC3-capable algorithm to generate a DNSSEC key. If this option is used with an algorithm that has both NSEC and NSEC3 versions, then the NSEC3 version is used; for example, `dnssec-keygen -3a RSASHA1` specifies the NSEC3RSASHA1 (deprecated) algorithm.
- E engine** This option specifies the cryptographic hardware to use.  
When BIND 9 is built with OpenSSL, this needs to be set to the OpenSSL engine identifier that drives the cryptographic accelerator or hardware service module (usually `pkcs11`).
- l label** This option specifies the label for a key pair in the crypto hardware.  
When BIND 9 is built with OpenSSL-based PKCS#11 support, the label is an arbitrary string that identifies a particular key. It may be preceded by an optional OpenSSL engine name, followed by a colon, as in `pkcs11:keylabel`.
- n nametype** This option specifies the owner type of the key. The value of `nametype` must either be `ZONE` (for a DNSSEC zone key (KEY/DNSKEY)), `HOST` or `ENTITY` (for a key associated with a host (KEY)), `USER` (for a key associated with a user (KEY)), or `OTHER` (DNSKEY). These values are case-insensitive.
- C** This option enables compatibility mode, which generates an old-style key, without any metadata. By default, `dnssec-keyfromlabel` includes the key's creation date in the metadata stored with the private key; other dates may be set there as well, including publication date, activation date, etc. Keys that include this data may be incompatible with older versions of BIND; the `-C` option suppresses them.
- c class** This option indicates that the DNS record containing the key should have the specified class. If not specified, class `IN` is used.
- f flag** This option sets the specified flag in the `flag` field of the KEY/DNSKEY record. The only recognized flags are `KSK` (Key-Signing Key) and `REVOKE`.
- G** This option generates a key, but does not publish it or sign with it. This option is incompatible with `-P` and `-A`.
- h** This option prints a short summary of the options and arguments to `dnssec-keyfromlabel`.
- K directory** This option sets the directory in which the key files are to be written.
- k** This option generates KEY records rather than DNSKEY records.
- L ttl** This option sets the default TTL to use for this key when it is converted into a DNSKEY RR. This is the TTL used when the key is imported into a zone, unless there was already a DNSKEY RRset in place, in which case the existing TTL would take precedence. Setting the default TTL to `0` or `none` removes it.
- p protocol** This option sets the protocol value for the key. The protocol is a number between 0 and 255. The default is 3 (DNSSEC). Other possible values for this argument are listed in [RFC 2535](#) and its successors.

**-s** *key*

This option generates a key as an explicit successor to an existing key. The name, algorithm, size, and type of the key are set to match the predecessor. The activation date of the new key is set to the inactivation date of the existing one. The publication date is set to the activation date minus the prepublication interval, which defaults to 30 days.

**-t** *type*

This option indicates the type of the key. *type* must be one of AUTHCONF, NOAUTHCONF, NOAUTH, or NOCONF. The default is AUTHCONF. AUTH refers to the ability to authenticate data, and CONF to the ability to encrypt data.

**-v** *level*

This option sets the debugging level.

**-V**

This option prints version information.

**-y**

This option allows DNSSEC key files to be generated even if the key ID would collide with that of an existing key, in the event of either key being revoked. (This is only safe to enable if [RFC 5011](#) trust anchor maintenance is not used with either of the keys involved.)

## 12.8.4 Timing Options

Dates can be expressed in the format YYYYMMDD or YYYYMMDDHHMMSS (which is the format used inside key files), or 'Day Mon DD HH:MM:SS YYYY' (as printed by `dnssec-settime -p`), or UNIX epoch time (as printed by `dnssec-settime -up`), or the literal `now`.

The argument can be followed by `+` or `-` and an offset from the given time. The literal `now` can be omitted before an offset. The offset can be followed by one of the suffixes `y`, `mo`, `w`, `d`, `h`, or `mi`, so that it is computed in years (defined as 365 24-hour days, ignoring leap years), months (defined as 30 24-hour days), weeks, days, hours, or minutes, respectively. Without a suffix, the offset is computed in seconds.

To explicitly prevent a date from being set, use `none`, `never`, or `unset`.

All these formats are case-insensitive.

**-P** *date/offset*

This option sets the date on which a key is to be published to the zone. After that date, the key is included in the zone but is not used to sign it. If not set, and if the `-G` option has not been used, the default is the current date.

**sync** *date/offset*

This option sets the date on which CDS and CDNSKEY records that match this key are to be published to the zone.

**-A** *date/offset*

This option sets the date on which the key is to be activated. After that date, the key is included in the zone and used to sign it. If not set, and if the `-G` option has not been used, the default is the current date.

**-R** *date/offset*

This option sets the date on which the key is to be revoked. After that date, the key is flagged as revoked. It is included in the zone and is used to sign it.

**-I** *date/offset*

This option sets the date on which the key is to be retired. After that date, the key is still included in the zone, but it is not used to sign it.

**-D** *date/offset*

This option sets the date on which the key is to be deleted. After that date, the key is no longer included in the zone. (However, it may remain in the key repository.)

**sync** *date/offset*

This option sets the date on which the CDS and CDNSKEY records that match this key are to be deleted.

**-i** *interval*

This option sets the prepublication interval for a key. If set, then the publication and activation dates must be separated by at least this much time. If the activation date is specified but the publication date is not, the publication date defaults to this much time before the activation date; conversely, if the publication date is specified but not the activation date, activation is set to this much time after publication.

If the key is being created as an explicit successor to another key, then the default prepublication interval is 30 days; otherwise it is zero.

As with date offsets, if the argument is followed by one of the suffixes *y*, *mo*, *w*, *d*, *h*, or *mi*, the interval is measured in years, months, weeks, days, hours, or minutes, respectively. Without a suffix, the interval is measured in seconds.

## 12.8.5 Generated Key Files

When **dnssec-keyfromlabel** completes successfully, it prints a string of the form `Knnnn.+aaa+iiii` to the standard output. This is an identification string for the key files it has generated.

- `n` is the key name.
- `aaa` is the numeric representation of the algorithm.
- `iiii` is the key identifier (or footprint).

**dnssec-keyfromlabel** creates two files, with names based on the printed string. `Knnnn.+aaa+iiii.key` contains the public key, and `Knnnn.+aaa+iiii.private` contains the private key.

The `.key` file contains a DNS KEY record that can be inserted into a zone file (directly or with an `$INCLUDE` statement).

The `.private` file contains algorithm-specific fields. For obvious security reasons, this file does not have general read permission.

## 12.8.6 See Also

*dnssec-keygen(8)*, *dnssec-signzone(8)*, BIND 9 Administrator Reference Manual, [RFC 4034](#), [RFC 7512](#).

# 12.9 dnssec-keygen: DNSSEC key generation tool

## 12.9.1 Synopsis

**dnssec-keygen** [-3] [-A *date/offset*] [-a *algorithm*] [-b *keysize*] [-C] [-c *class*] [-D *date/offset*] [-d *bits*] [-D *sync date/offset*] [-E *engine*] [-f *flag*] [-G] [-g *generator*] [-h] [-I *date/offset*] [-i *interval*] [-K *directory*] [-k *policy*] [-L *t*] [-l *file*] [-n *nametype*] [-P *date/offset*] [-P *sync date/offset*] [-p *protocol*] [-q] [-R *date/offset*] [-S *key*] [-s *strength*] [-T *rrtype*] [-t *type*] [-V] [-v *level*] {*name*}

## 12.9.2 Description

**dnssec-keygen** generates keys for DNSSEC (Secure DNS), as defined in [RFC 2535](#) and [RFC 4034](#).

The `name` of the key is specified on the command line. For DNSSEC keys, this must match the name of the zone for which the key is being generated.

### 12.9.3 Options

**-3**

This option uses an NSEC3-capable algorithm to generate a DNSSEC key. If this option is used with an algorithm that has both NSEC and NSEC3 versions, then the NSEC3 version is selected; for example, `dnssec-keygen -3 -a RSASHA1` specifies the NSEC3RSASHA1 (deprecated) algorithm.

**-a** `algorithm`

This option selects the cryptographic algorithm. For DNSSEC keys, the value of `algorithm` must be one of RSASHA1 (deprecated), NSEC3RSASHA1 (deprecated), RSASHA256, RSASHA512, ECDSAP256SHA256, ECDSAP384SHA384, ED25519, or ED448. For TKEY, the value must be DH (Diffie-Hellman); specifying this value automatically sets the `-T KEY` option as well.

These values are case-insensitive. In some cases, abbreviations are supported, such as ECDSA256 for ECDSAP256SHA256 and ECDSA384 for ECDSAP384SHA384. If RSASHA1 (deprecated) is specified along with the `-3` option, NSEC3RSASHA1 (deprecated) is used instead.

This parameter *must* be specified except when using the `-s` option, which copies the algorithm from the predecessor key.

In prior releases, HMAC algorithms could be generated for use as TSIG keys, but that feature was removed in BIND 9.13.0. Use `tsig-keygen` to generate TSIG keys.

**-b** `keysize`

This option specifies the number of bits in the key. The choice of key size depends on the algorithm used: RSA keys must be between 1024 and 4096 bits; Diffie-Hellman keys must be between 128 and 4096 bits. Elliptic curve algorithms do not need this parameter.

If the key size is not specified, some algorithms have pre-defined defaults. For example, RSA keys for use as DNSSEC zone-signing keys have a default size of 1024 bits; RSA keys for use as key-signing keys (KSKs, generated with `-f KSK`) default to 2048 bits.

**-c**

This option enables compatibility mode, which generates an old-style key, without any timing metadata. By default, `dnssec-keygen` includes the key's creation date in the metadata stored with the private key; other dates may be set there as well, including publication date, activation date, etc. Keys that include this data may be incompatible with older versions of BIND; the `-c` option suppresses them.

**-c** `class`

This option indicates that the DNS record containing the key should have the specified class. If not specified, class IN is used.

**-d** `bits`

This option specifies the key size in bits. For the algorithms RSASHA1, NSEC3RSASA1, RSASHA256, and RSASHA512 the key size must be between 1024 and 4096 bits; DH size is between 128 and 4096 bits. This option is ignored for algorithms ECDSAP256SHA256, ECDSAP384SHA384, ED25519, and ED448.

**-E** `engine`

This option specifies the cryptographic hardware to use, when applicable.

When BIND 9 is built with OpenSSL, this needs to be set to the OpenSSL engine identifier that drives the cryptographic accelerator or hardware service module (usually `pkcs11`).

**-f** `flag`

This option sets the specified flag in the flag field of the KEY/DNSKEY record. The only recognized flags are KSK (Key-Signing Key) and REVOKE.

- G** This option generates a key, but does not publish it or sign with it. This option is incompatible with `-P` and `-A`.
- g** *generator* This option indicates the generator to use if generating a Diffie-Hellman key. Allowed values are 2 and 5. If no generator is specified, a known prime from [RFC 2539](#) is used if possible; otherwise the default is 2.
- h** This option prints a short summary of the options and arguments to `dnssec-keygen`.
- K** *directory* This option sets the directory in which the key files are to be written.
- k** *policy* This option creates keys for a specific `dnssec-policy`. If a policy uses multiple keys, `dnssec-keygen` generates multiple keys. This also creates a ".state" file to keep track of the key state.
- This option creates keys according to the `dnssec-policy` configuration, hence it cannot be used at the same time as many of the other options that `dnssec-keygen` provides.
- L** *ttl* This option sets the default TTL to use for this key when it is converted into a DNSKEY RR. This is the TTL used when the key is imported into a zone, unless there was already a DNSKEY RRset in place, in which case the existing TTL takes precedence. If this value is not set and there is no existing DNSKEY RRset, the TTL defaults to the SOA TTL. Setting the default TTL to 0 or `none` is the same as leaving it unset.
- l** *file* This option provides a configuration file that contains a `dnssec-policy` statement (matching the policy set with `-k`).
- n** *nametype* This option specifies the owner type of the key. The value of `nametype` must either be `ZONE` (for a DNSSEC zone key (KEY/DNSKEY)), `HOST` or `ENTITY` (for a key associated with a host (KEY)), `USER` (for a key associated with a user (KEY)), or `OTHER` (DNSKEY). These values are case-insensitive. The default is `ZONE` for DNSKEY generation.
- p** *protocol* This option sets the protocol value for the generated key, for use with `-T KEY`. The protocol is a number between 0 and 255. The default is 3 (DNSSEC). Other possible values for this argument are listed in [RFC 2535](#) and its successors.
- q** This option sets quiet mode, which suppresses unnecessary output, including progress indication. Without this option, when `dnssec-keygen` is run interactively to generate a RSA or DSA key pair, it prints a string of symbols to `stderr` indicating the progress of the key generation. A `.` indicates that a random number has been found which passed an initial sieve test; `+` means a number has passed a single round of the Miller-Rabin primality test; and a space () means that the number has passed all the tests and is a satisfactory key.
- S** *key* This option creates a new key which is an explicit successor to an existing key. The name, algorithm, size, and type of the key are set to match the existing key. The activation date of the new key is set to the inactivation date of the existing one. The publication date is set to the activation date minus the prepublication interval, which defaults to 30 days.
- s** *strength* This option specifies the strength value of the key. The strength is a number between 0 and 15, and currently has no defined purpose in DNSSEC.

**-T** *rrtype*

This option specifies the resource record type to use for the key. *rrtype* must be either `DNSKEY` or `KEY`. The default is `DNSKEY` when using a DNSSEC algorithm, but it can be overridden to `KEY` for use with `SIG(0)`.

**-t** *type*

This option indicates the type of the key for use with **-T** *KEY*. *type* must be one of `AUTHCONF`, `NOAUTHCONF`, `NOAUTH`, or `NOCONF`. The default is `AUTHCONF`. `AUTH` refers to the ability to authenticate data, and `CONF` to the ability to encrypt data.

**-v**

This option prints version information.

**-v** *level*

This option sets the debugging level.

## 12.9.4 Timing Options

Dates can be expressed in the format `YYYYMMDD` or `YYYYMMDDHHMMSS` (which is the format used inside key files), or 'Day Mon DD HH:MM:SS YYYY' (as printed by `dnssec-settime -p`), or UNIX epoch time (as printed by `dnssec-settime -up`), or the literal `now`.

The argument can be followed by `+` or `-` and an offset from the given time. The literal `now` can be omitted before an offset. The offset can be followed by one of the suffixes `y`, `mo`, `w`, `d`, `h`, or `mi`, so that it is computed in years (defined as 365 24-hour days, ignoring leap years), months (defined as 30 24-hour days), weeks, days, hours, or minutes, respectively. Without a suffix, the offset is computed in seconds.

To unset a date, use `none`, `never`, or `unset`.

**-P** *date/offset*

This option sets the date on which a key is to be published to the zone. After that date, the key is included in the zone but is not used to sign it. If not set, and if the **-G** option has not been used, the default is the current date.

**sync** *date/offset*

This option sets the date on which CDS and CDNSKEY records that match this key are to be published to the zone.

**-A** *date/offset*

This option sets the date on which the key is to be activated. After that date, the key is included in the zone and used to sign it. If not set, and if the **-G** option has not been used, the default is the current date. If set, and **-P** is not set, the publication date is set to the activation date minus the prepublication interval.

**-R** *date/offset*

This option sets the date on which the key is to be revoked. After that date, the key is flagged as revoked. It is included in the zone and is used to sign it.

**-I** *date/offset*

This option sets the date on which the key is to be retired. After that date, the key is still included in the zone, but it is not used to sign it.

**-D** *date/offset*

This option sets the date on which the key is to be deleted. After that date, the key is no longer included in the zone. (However, it may remain in the key repository.)

**sync** *date/offset*

This option sets the date on which the CDS and CDNSKEY records that match this key are to be deleted.

**-i** interval

This option sets the prepublication interval for a key. If set, then the publication and activation dates must be separated by at least this much time. If the activation date is specified but the publication date is not, the publication date defaults to this much time before the activation date; conversely, if the publication date is specified but not the activation date, activation is set to this much time after publication.

If the key is being created as an explicit successor to another key, then the default prepublication interval is 30 days; otherwise it is zero.

As with date offsets, if the argument is followed by one of the suffixes *y*, *mo*, *w*, *d*, *h*, or *mi*, the interval is measured in years, months, weeks, days, hours, or minutes, respectively. Without a suffix, the interval is measured in seconds.

## 12.9.5 Generated Keys

When **dnssec-keygen** completes successfully, it prints a string of the form `Knnnn.+aaa+iiii` to the standard output. This is an identification string for the key it has generated.

- `nnnn` is the key name.
- `aaa` is the numeric representation of the algorithm.
- `iiii` is the key identifier (or footprint).

**dnssec-keygen** creates two files, with names based on the printed string. `Knnnn.+aaa+iiii.key` contains the public key, and `Knnnn.+aaa+iiii.private` contains the private key.

The `.key` file contains a DNSKEY or KEY record. When a zone is being signed by *named* or *dnssec-signzone -S*, DNSKEY records are included automatically. In other cases, the `.key` file can be inserted into a zone file manually or with an `$INCLUDE` statement.

The `.private` file contains algorithm-specific fields. For obvious security reasons, this file does not have general read permission.

## 12.9.6 Example

To generate an ECDSAP256SHA256 zone-signing key for the zone `example.com`, issue the command:

```
dnssec-keygen -a ECDSAP256SHA256 example.com
```

The command prints a string of the form:

```
Kexample.com.+013+26160
```

In this example, **dnssec-keygen** creates the files `Kexample.com.+013+26160.key` and `Kexample.com.+013+26160.private`.

To generate a matching key-signing key, issue the command:

```
dnssec-keygen -a ECDSAP256SHA256 -f KSK example.com
```

## 12.9.7 See Also

*dnssec-signzone* (8), BIND 9 Administrator Reference Manual, [RFC 2539](#), [RFC 2845](#), [RFC 4034](#).

## 12.10 dnssec-revoke - set the REVOKED bit on a DNSSEC key

### 12.10.1 Synopsis

```
dnssec-revoke [-hr] [-v level] [-V] [-K directory] [-E engine] [-f] [-R] {keyfile}
```

## 12.10.2 Description

**dnssec-revoke** reads a DNSSEC key file, sets the REVOKED bit on the key as defined in [RFC 5011](#), and creates a new pair of key files containing the now-revoked key.

## 12.10.3 Options

**-h**

This option emits a usage message and exits.

**-K** *directory*

This option sets the directory in which the key files are to reside.

**-r**

This option indicates to remove the original keyset files after writing the new keyset files.

**-v** *level*

This option sets the debugging level.

**-V**

This option prints version information.

**-E** *engine*

This option specifies the cryptographic hardware to use, when applicable.

When BIND 9 is built with OpenSSL, this needs to be set to the OpenSSL engine identifier that drives the cryptographic accelerator or hardware service module (usually `pkcs11`).

**-f**

This option indicates a forced overwrite and causes **dnssec-revoke** to write the new key pair, even if a file already exists matching the algorithm and key ID of the revoked key.

**-R**

This option prints the key tag of the key with the REVOKE bit set, but does not revoke the key.

## 12.10.4 See Also

*dnssec-keygen* (8), BIND 9 Administrator Reference Manual, [RFC 5011](#).

## 12.11 dnssec-settime: set the key timing metadata for a DNSSEC key

### 12.11.1 Synopsis

```
dnssec-settime [-f] [-K directory] [-L ttl] [-P date/offset] [-P ds date/offset] [-P sync date/offset] [-A date/offset]
[-R date/offset] [-I date/offset] [-D date/offset] [-D ds date/offset] [-D sync date/offset] [-S key] [-i interval] [-h] [-V]
[-v level] [-E engine] [keyfile] [-s] [-g state] [-d state date/offset] [-k state date/offset] [-r state date/offset] [-z state date/offset]
```

### 12.11.2 Description

**dnssec-settime** reads a DNSSEC private key file and sets the key timing metadata as specified by the `-P`, `-A`, `-R`, `-I`, and `-D` options. The metadata can then be used by *dnssec-signzone* or other signing software to determine when a key is to be published, whether it should be used for signing a zone, etc.

If none of these options is set on the command line, **dnssec-settime** simply prints the key timing metadata already stored in the key.

When key metadata fields are changed, both files of a key pair (`Knnnn.+aaa+iiii.key` and `Knnnn.+aaa+iiii.private`) are regenerated.

Metadata fields are stored in the private file. A human-readable description of the metadata is also placed in comments in the key file. The private file's permissions are always set to be inaccessible to anyone other than the owner (mode 0600).

When working with state files, it is possible to update the timing metadata in those files as well with `-s`. With this option, it is also possible to update key states with `-d` (DS), `-k` (DNSKEY), `-r` (RRSIG of KSK), or `-z` (RRSIG of ZSK). Allowed states are `HIDDEN`, `RUMOURED`, `OMNIPRESENT`, and `UNRETENTIVE`.

The goal state of the key can also be set with `-g`. This should be either `HIDDEN` or `OMNIPRESENT`, representing whether the key should be removed from the zone or published.

It is NOT RECOMMENDED to manipulate state files manually, except for testing purposes.

### 12.11.3 Options

**-f**

This option forces an update of an old-format key with no metadata fields. Without this option, `dnssec-settime` fails when attempting to update a legacy key. With this option, the key is recreated in the new format, but with the original key data retained. The key's creation date is set to the present time. If no other values are specified, then the key's publication and activation dates are also set to the present time.

**-K** *directory*

This option sets the directory in which the key files are to reside.

**-L** *ttl*

This option sets the default TTL to use for this key when it is converted into a DNSKEY RR. This is the TTL used when the key is imported into a zone, unless there was already a DNSKEY RRset in place, in which case the existing TTL takes precedence. If this value is not set and there is no existing DNSKEY RRset, the TTL defaults to the SOA TTL. Setting the default TTL to 0 or `none` removes it from the key.

**-h**

This option emits a usage message and exits.

**-v**

This option prints version information.

**-v** *level*

This option sets the debugging level.

**-E** *engine*

This option specifies the cryptographic hardware to use, when applicable.

When BIND 9 is built with OpenSSL, this needs to be set to the OpenSSL engine identifier that drives the cryptographic accelerator or hardware service module (usually `pkcs11`).

### 12.11.4 Timing Options

Dates can be expressed in the format `YYYYMMDD` or `YYYYMMDDHHMMSS` (which is the format used inside key files), or `'Day Mon DD HH:MM:SS YYYY'` (as printed by `dnssec-settime -p`), or UNIX epoch time (as printed by `dnssec-settime -up`), or the literal `now`.

The argument can be followed by `+` or `-` and an offset from the given time. The literal `now` can be omitted before an offset. The offset can be followed by one of the suffixes `y`, `mo`, `w`, `d`, `h`, or `mi`, so that it is computed in years (defined as 365 24-hour days, ignoring leap years), months (defined as 30 24-hour days), weeks, days, hours, or minutes, respectively. Without a suffix, the offset is computed in seconds.

To unset a date, use `none`, `never`, or `unset`.

All these formats are case-insensitive.

**-P** `date/offset`

This option sets the date on which a key is to be published to the zone. After that date, the key is included in the zone but is not used to sign it.

**ds** `date/offset`

This option sets the date on which DS records that match this key have been seen in the parent zone.

**sync** `date/offset`

This option sets the date on which CDS and CDNSKEY records that match this key are to be published to the zone.

**-A** `date/offset`

This option sets the date on which the key is to be activated. After that date, the key is included in the zone and used to sign it.

**-R** `date/offset`

This option sets the date on which the key is to be revoked. After that date, the key is flagged as revoked. It is included in the zone and is used to sign it.

**-I** `date/offset`

This option sets the date on which the key is to be retired. After that date, the key is still included in the zone, but it is not used to sign it.

**-D** `date/offset`

This option sets the date on which the key is to be deleted. After that date, the key is no longer included in the zone. (However, it may remain in the key repository.)

**ds** `date/offset`

This option sets the date on which the DS records that match this key have been seen removed from the parent zone.

**sync** `date/offset`

This option sets the date on which the CDS and CDNSKEY records that match this key are to be deleted.

**-S** `predecessor key`

This option selects a key for which the key being modified is an explicit successor. The name, algorithm, size, and type of the predecessor key must exactly match those of the key being modified. The activation date of the successor key is set to the inactivation date of the predecessor. The publication date is set to the activation date minus the prepublication interval, which defaults to 30 days.

**-i** `interval`

This option sets the prepublication interval for a key. If set, then the publication and activation dates must be separated by at least this much time. If the activation date is specified but the publication date is not, the publication date defaults to this much time before the activation date; conversely, if the publication date is specified but not the activation date, activation is set to this much time after publication.

If the key is being created as an explicit successor to another key, then the default prepublication interval is 30 days; otherwise it is zero.

As with date offsets, if the argument is followed by one of the suffixes `y`, `mo`, `w`, `d`, `h`, or `mi`, the interval is measured in years, months, weeks, days, hours, or minutes, respectively. Without a suffix, the interval is measured in seconds.

### 12.11.5 Key State Options

To test dnssec-policy it may be necessary to construct keys with artificial state information; these options are used by the testing framework for that purpose, but should never be used in production.

Known key states are `HIDDEN`, `RUMOURED`, `OMNIPRESENT`, and `UNRETENTIVE`.

**-s**

This option indicates that when setting key timing data, the state file should also be updated.

**-g** *state*

This option sets the goal state for this key. Must be `HIDDEN` or `OMNIPRESENT`.

**-d** *state date/offset*

This option sets the DS state for this key as of the specified date, offset from the current date.

**-k** *state date/offset*

This option sets the DNSKEY state for this key as of the specified date, offset from the current date.

**-r** *state date/offset*

This option sets the RRSIG (KSK) state for this key as of the specified date, offset from the current date.

**-z** *state date/offset*

This option sets the RRSIG (ZSK) state for this key as of the specified date, offset from the current date.

### 12.11.6 Printing Options

`dnssec-settime` can also be used to print the timing metadata associated with a key.

**-u**

This option indicates that times should be printed in Unix epoch format.

**-p** *C/P/Pds/A/R/I/D/Dds/Dsync/all*

This option prints a specific metadata value or set of metadata values. The `-p` option may be followed by one or more of the following letters or strings to indicate which value or values to print: `C` for the creation date, `P` for the publication date, `Pds`` for the DS publication date, ```Psync` for the CDS and CDNSKEY publication date, `A` for the activation date, `R` for the revocation date, `I` for the inactivation date, `D` for the deletion date, `Dds` for the DS deletion date, and `Dsync` for the CDS and CDNSKEY deletion date. To print all of the metadata, use `all`.

### 12.11.7 See Also

*dnssec-keygen (8)*, *dnssec-signzone (8)*, BIND 9 Administrator Reference Manual, [RFC 5011](#).

## 12.12 dnssec-signzone - DNSSEC zone signing tool

### 12.12.1 Synopsis

`dnssec-signzone` [-a] [-c class] [-d directory] [-D] [-E engine] [-e end-time] [-f output-file] [-g] [-h] [-i interval] [-I input-format] [-j jitter] [-K directory] [-k key] [-L serial] [-M maxttl] [-N soa-serial-format] [-o origin] [-O output-format] [-P] [-Q] [-q] [-R] [-S] [-s start-time] [-T ttl] [-t] [-u] [-v level] [-V] [-X extended end-time] [-x] [-z] [-3 salt] [-H iterations] [-A] {zonefile} [key...]

## 12.12.2 Description

**dnssec-signzone** signs a zone; it generates NSEC and RRSIG records and produces a signed version of the zone. The security status of delegations from the signed zone (that is, whether the child zones are secure) is determined by the presence or absence of a `keyset` file for each child zone.

## 12.12.3 Options

**-a**

This option verifies all generated signatures.

**-c** `class`

This option specifies the DNS class of the zone.

**-C**

This option sets compatibility mode, in which a `keyset-zonename` file is generated in addition to `dsset-zonename` when signing a zone, for use by older versions of **dnssec-signzone**.

**-d** `directory`

This option indicates the directory where BIND 9 should look for `dsset-` or `keyset-` files.

**-D**

This option indicates that only those record types automatically managed by **dnssec-signzone**, i.e., RRSIG, NSEC, NSEC3 and NSEC3PARAM records, should be included in the output. If smart signing (`-S`) is used, DNSKEY records are also included. The resulting file can be included in the original zone file with `$INCLUDE`. This option cannot be combined with `-O raw` or serial-number updating.

**-E** `engine`

This option specifies the hardware to use for cryptographic operations, such as a secure key store used for signing, when applicable.

When BIND 9 is built with OpenSSL, this needs to be set to the OpenSSL engine identifier that drives the cryptographic accelerator or hardware service module (usually `pkcs11`).

**-g**

This option indicates that DS records for child zones should be generated from a `dsset-` or `keyset-` file. Existing DS records are removed.

**-K** `directory`

This option specifies the directory to search for DNSSEC keys. If not specified, it defaults to the current directory.

**-k** `key`

This option tells BIND 9 to treat the specified key as a key-signing key, ignoring any key flags. This option may be specified multiple times.

**-M** `maxttl`

This option sets the maximum TTL for the signed zone. Any TTL higher than `maxttl` in the input zone is reduced to `maxttl` in the output. This provides certainty as to the largest possible TTL in the signed zone, which is useful to know when rolling keys. The `maxttl` is the longest possible time before signatures that have been retrieved by resolvers expire from resolver caches. Zones that are signed with this option should be configured to use a matching `max-zone-ttl` in `named.conf`. (Note: This option is incompatible with `-D`, because it modifies non-DNSSEC data in the output zone.)

**-s** `start-time`

This option specifies the date and time when the generated RRSIG records become valid. This can be either an absolute or relative time. An absolute start time is indicated by a number in YYYYMMDDHHMMSS notation; 20000530144500 denotes 14:45:00 UTC on May 30th, 2000. A relative start time is indicated by `+N`, which is N

seconds from the current time. If no `start-time` is specified, the current time minus 1 hour (to allow for clock skew) is used.

**-e** `end-time`

This option specifies the date and time when the generated RRSIG records expire. As with `start-time`, an absolute time is indicated in YYYYMMDDHHMMSS notation. A time relative to the start time is indicated with `+N`, which is N seconds from the start time. A time relative to the current time is indicated with `now+N`. If no `end-time` is specified, 30 days from the start time is the default. `end-time` must be later than `start-time`.

**-X** `extended end-time`

This option specifies the date and time when the generated RRSIG records for the DNSKEY RRset expire. This is to be used in cases when the DNSKEY signatures need to persist longer than signatures on other records; e.g., when the private component of the KSK is kept offline and the KSK signature is to be refreshed manually.

As with `end-time`, an absolute time is indicated in YYYYMMDDHHMMSS notation. A time relative to the start time is indicated with `+N`, which is N seconds from the start time. A time relative to the current time is indicated with `now+N`. If no `extended end-time` is specified, the value of `end-time` is used as the default. (`end-time`, in turn, defaults to 30 days from the start time.) `extended end-time` must be later than `start-time`.

**-f** `output-file`

This option indicates the name of the output file containing the signed zone. The default is to append `.signed` to the input filename. If `output-file` is set to `-`, then the signed zone is written to the standard output, with a default output format of `full`.

**-h**

This option prints a short summary of the options and arguments to `dnssec-signzone`.

**-v**

This option prints version information.

**-i** `interval`

This option indicates that, when a previously signed zone is passed as input, records may be re-signed. The `interval` option specifies the cycle interval as an offset from the current time, in seconds. If a RRSIG record expires after the cycle interval, it is retained; otherwise, it is considered to be expiring soon and it is replaced.

The default cycle interval is one quarter of the difference between the signature end and start times. So if neither `end-time` nor `start-time` is specified, `dnssec-signzone` generates signatures that are valid for 30 days, with a cycle interval of 7.5 days. Therefore, if any existing RRSIG records are due to expire in less than 7.5 days, they are replaced.

Note that the calculation of cycle interval is based upon the validity period of the replacement signatures that would be generated by `dnssec-signzone`, not on the valid lifetimes of the input RRSIGs being considered for pre-expiry replacement.

**-I** `input-format`

This option sets the format of the input zone file. Possible formats are `text` (the default), and `raw`. This option is primarily intended to be used for dynamic signed zones, so that the dumped zone file in a non-text format containing updates can be signed directly. This option is not useful for non-dynamic zones.

**-j** `jitter`

When signing a zone with a fixed signature lifetime, all RRSIG records issued at the time of signing expire simultaneously. If the zone is incrementally signed, i.e., a previously signed zone is passed as input to the signer, all expired signatures must be regenerated at approximately the same time. The `jitter` option specifies a jitter window that is used to randomize the signature expire time, thus spreading incremental signature regeneration over time.

Signature lifetime jitter also, to some extent, benefits validators and servers by spreading out cache expiration, i.e., if large numbers of RRSIGs do not expire at the same time from all caches, there is less congestion than if all validators need to refetch at around the same time.

**-L** `serial`

When writing a signed zone to "raw" format, this option sets the "source serial" value in the header to the specified serial number. (This is expected to be used primarily for testing purposes.)

**-n** `ncpus`

This option specifies the number of threads to use. By default, one thread is started for each detected CPU.

**-N** `soa-serial-format`

This option sets the SOA serial number format of the signed zone. Possible formats are `keep` (the default), `increment`, `unixtime`, and `date`.

**keep**

This format indicates that the SOA serial number should not be modified.

**increment**

This format increments the SOA serial number using [RFC 1982](#) arithmetic.

**unixtime**

This format sets the SOA serial number to the number of seconds since the beginning of the Unix epoch, unless the serial number is already greater than or equal to that value, in which case it is simply incremented by one.

**date**

This format sets the SOA serial number to today's date, in YYYYMMDDNN format, unless the serial number is already greater than or equal to that value, in which case it is simply incremented by one.

**-o** `origin`

This option sets the zone origin. If not specified, the name of the zone file is assumed to be the origin.

**-O** `output-format`

This option sets the format of the output file containing the signed zone. Possible formats are `text` (the default), which is the standard textual representation of the zone; `full`, which is text output in a format suitable for processing by external scripts; and `raw` and `raw=N`, which store the zone in binary formats for rapid loading by `named`. `raw=N` specifies the format version of the raw zone file: if N is 0, the raw file can be read by any version of `named`; if N is 1, the file can be read by release 9.9.0 or higher. The default is 1.

**-P**

This option disables post-sign verification tests.

The post-sign verification tests ensure that for each algorithm in use there is at least one non-revoked self-signed KSK key, that all revoked KSK keys are self-signed, and that all records in the zone are signed by the algorithm. This option skips these tests.

**-Q**

This option removes signatures from keys that are no longer active.

Normally, when a previously signed zone is passed as input to the signer, and a DNSKEY record has been removed and replaced with a new one, signatures from the old key that are still within their validity period are retained. This allows the zone to continue to validate with cached copies of the old DNSKEY RRset. The `-Q` option forces `dnssec-signzone` to remove signatures from keys that are no longer active. This enables ZSK rollover using the procedure described in [RFC 6781 Section 4.1.1.1](#) ("Pre-Publish Zone Signing Key Rollover").

**-q**

This option enables quiet mode, which suppresses unnecessary output. Without this option, when `dnssec-signzone` is run it prints three pieces of information to standard output: the number of keys in use; the algorithms used to verify the zone was signed correctly and other status information; and the filename containing the signed zone. With the option that output is suppressed, leaving only the filename.

**-R**

This option removes signatures from keys that are no longer published.

This option is similar to `-Q`, except it forces `dnssec-signzone` to remove signatures from keys that are no longer published. This enables ZSK rollover using the procedure described in [RFC 6781 Section 4.1.1.2](#) ("Double Signature Zone Signing Key Rollover").

**-S**

This option enables smart signing, which instructs `dnssec-signzone` to search the key repository for keys that match the zone being signed, and to include them in the zone if appropriate.

When a key is found, its timing metadata is examined to determine how it should be used, according to the following rules. Each successive rule takes priority over the prior ones:

If no timing metadata has been set for the key, the key is published in the zone and used to sign the zone.

If the key's publication date is set and is in the past, the key is published in the zone.

If the key's activation date is set and is in the past, the key is published (regardless of publication date) and used to sign the zone.

If the key's revocation date is set and is in the past, and the key is published, then the key is revoked, and the revoked key is used to sign the zone.

If either the key's unpublication or deletion date is set and in the past, the key is NOT published or used to sign the zone, regardless of any other metadata.

If the key's sync publication date is set and is in the past, synchronization records (type CDS and/or CDNSKEY) are created.

If the key's sync deletion date is set and is in the past, synchronization records (type CDS and/or CDNSKEY) are removed.

**-T** `t1`

This option specifies a TTL to be used for new DNSKEY records imported into the zone from the key repository. If not specified, the default is the TTL value from the zone's SOA record. This option is ignored when signing without `-S`, since DNSKEY records are not imported from the key repository in that case. It is also ignored if there are any pre-existing DNSKEY records at the zone apex, in which case new records' TTL values are set to match them, or if any of the imported DNSKEY records had a default TTL value. In the event of a conflict between TTL values in imported keys, the shortest one is used.

**-t**

This option prints statistics at completion.

**-u**

This option updates the NSEC/NSEC3 chain when re-signing a previously signed zone. With this option, a zone signed with NSEC can be switched to NSEC3, or a zone signed with NSEC3 can be switched to NSEC or to NSEC3 with different parameters. Without this option, `dnssec-signzone` retains the existing chain when re-signing.

**-v** `level`

This option sets the debugging level.

**-x**

This option indicates that BIND 9 should only sign the DNSKEY, CDNSKEY, and CDS RRsets with key-signing keys, and should omit signatures from zone-signing keys. (This is similar to the `dnssec-dnskey-kskonly yes; zone` option in `named`.)

**-z**

This option indicates that BIND 9 should ignore the KSK flag on keys when determining what to sign. This causes KSK-flagged keys to sign all records, not just the DNSKEY RRset. (This is similar to the `update-check-ksk no`; zone option in *named*.)

**-3 salt**

This option generates an NSEC3 chain with the given hex-encoded salt. A dash (-) can be used to indicate that no salt is to be used when generating the NSEC3 chain.

**Note**

`-3 -` is the recommended configuration. Adding salt provides no practical benefits. See [RFC 9276](#).

**-H iterations**

This option indicates that, when generating an NSEC3 chain, BIND 9 should use this many iterations. The default is 0.

**Warning**

Values greater than 0 cause interoperability issues and also increase the risk of CPU-exhausting DoS attacks. See [RFC 9276](#).

**-A**

This option indicates that, when generating an NSEC3 chain, BIND 9 should set the OPTOUT flag on all NSEC3 records and should not generate NSEC3 records for insecure delegations.

**Warning**

Do not use this option unless all its implications are fully understood. This option is intended only for extremely large zones (comparable to `com.`) with sparse secure delegations. See [RFC 9276](#).

**-AA**

This option turns the OPTOUT flag off for all records. This is useful when using the `-u` option to modify an NSEC3 chain which previously had OPTOUT set.

**zonefile**

This option sets the file containing the zone to be signed.

**key**

This option specifies which keys should be used to sign the zone. If no keys are specified, the zone is examined for DNSKEY records at the zone apex. If these records are found and there are matching private keys in the current directory, they are used for signing.

## 12.12.4 Example

The following command signs the `example.com` zone with the ECDSAP256SHA256 key generated by *dnssec-keygen* (`Kexample.com.+013+17247`). Because the `-s` option is not being used, the zone's keys must be in the master file (`db.example.com`). This invocation looks for `dsset` files in the current directory, so that DS records can be imported from them (`-g`).

```
% dnssec-signzone -g -o example.com db.example.com \
Kexample.com.+013+17247
db.example.com.signed
%
```

In the above example, **dnssec-signzone** creates the file `db.example.com.signed`. This file should be referenced in a zone statement in the `named.conf` file.

This example re-signs a previously signed zone with default parameters. The private keys are assumed to be in the current directory.

```
% cp db.example.com.signed db.example.com
% dnssec-signzone -o example.com db.example.com
db.example.com.signed
%
```

## 12.12.5 See Also

*dnssec-keygen* (8), BIND 9 Administrator Reference Manual, [RFC 4033](#), [RFC 6781](#).

## 12.13 dnssec-verify - DNSSEC zone verification tool

### 12.13.1 Synopsis

```
dnssec-verify [-c class] [-E engine] [-I input-format] [-o origin] [-q] [-v level] [-V] [-x] [-z] {zonefile}
```

### 12.13.2 Description

**dnssec-verify** verifies that a zone is fully signed for each algorithm found in the DNSKEY RRset for the zone, and that the NSEC/NSEC3 chains are complete.

### 12.13.3 Options

**-c** class

This option specifies the DNS class of the zone.

**-E** engine

This option specifies the cryptographic hardware to use, when applicable.

When BIND 9 is built with OpenSSL, this needs to be set to the OpenSSL engine identifier that drives the cryptographic accelerator or hardware service module (usually `pkcs11`).

**-I** input-format

This option sets the format of the input zone file. Possible formats are `text` (the default) and `raw`. This option is primarily intended to be used for dynamic signed zones, so that the dumped zone file in a non-text format containing updates can be verified independently. This option is not useful for non-dynamic zones.

**-o** origin

This option indicates the zone origin. If not specified, the name of the zone file is assumed to be the origin.

**-v** level

This option sets the debugging level.

**-v**

This option prints version information.

**-q**

This option sets quiet mode, which suppresses output. Without this option, when **dnssec-verify** is run it prints to standard output the number of keys in use, the algorithms used to verify the zone was signed correctly, and other status information. With this option, all non-error output is suppressed, and only the exit code indicates success.

**-x**

This option verifies only that the DNSKEY RRset is signed with key-signing keys. Without this flag, it is assumed that the DNSKEY RRset is signed by all active keys. When this flag is set, it is not an error if the DNSKEY RRset is not signed by zone-signing keys. This corresponds to the *-x option in dnssec-signzone*.

**-z**

This option indicates that the KSK flag on the keys should be ignored when determining whether the zone is correctly signed. Without this flag, it is assumed that there is a non-revoked, self-signed DNSKEY with the KSK flag set for each algorithm, and that RRsets other than DNSKEY RRset are signed with a different DNSKEY without the KSK flag set.

With this flag set, BIND 9 only requires that for each algorithm, there be at least one non-revoked, self-signed DNSKEY, regardless of the KSK flag state, and that other RRsets be signed by a non-revoked key for the same algorithm that includes the self-signed key; the same key may be used for both purposes. This corresponds to the *-z option in dnssec-signzone*.

**zonefile**

This option indicates the file containing the zone to be signed.

## 12.13.4 See Also

*dnssec-signzone(8)*, BIND 9 Administrator Reference Manual, [RFC 4033](#).

## 12.14 dnstap-read - print dnstap data in human-readable form

### 12.14.1 Synopsis

**dnstap-read** [-m] [-p] [-x] [-y] {file}

### 12.14.2 Description

**dnstap-read** reads `dnstap` data from a specified file and prints it in a human-readable format. By default, `dnstap` data is printed in a short summary format, but if the `-y` option is specified, a longer and more detailed YAML format is used.

### 12.14.3 Options

**-m**

This option indicates trace memory allocations, and is used for debugging memory leaks.

**-p**

This option prints the text form of the DNS message that was encapsulated in the `dnstap` frame, after printing the `dnstap` data.

**-x**

This option prints a hex dump of the wire form of the DNS message that was encapsulated in the `dnstap` frame, after printing the `dnstap` data.

**-y**

This option prints `dnstap` data in a detailed YAML format.

## 12.14.4 See Also

`named(8)`, `rndc(8)`, BIND 9 Administrator Reference Manual.

## 12.15 filter-aaaa.so - filter AAAA in DNS responses when A is present

### 12.15.1 Synopsis

```
plugin query "filter-aaaa.so" [{ parameters }];
```

### 12.15.2 Description

**filter-aaaa.so** is a query plugin module for `named`, enabling `named` to omit some IPv6 addresses when responding to clients.

Until BIND 9.12, this feature was implemented natively in `named` and enabled with the `filter-aaaa` ACL and the `filter-aaaa-on-v4` and `filter-aaaa-on-v6` options. These options are now deprecated in `named.conf` but can be passed as parameters to the `filter-aaaa.so` plugin, for example:

```
plugin query "filter-aaaa.so" {
    filter-aaaa-on-v4 yes;
    filter-aaaa-on-v6 yes;
    filter-aaaa { 192.0.2.1; 2001:db8:2::1; };
};
```

This module is intended to aid transition from IPv4 to IPv6 by withholding IPv6 addresses from DNS clients which are not connected to the IPv6 Internet, when the name being looked up has an IPv4 address available. Use of this module is not recommended unless absolutely necessary.

Note: This mechanism can erroneously cause other servers not to give AAAA records to their clients. If a recursing server with both IPv6 and IPv4 network connections queries an authoritative server using this mechanism via IPv4, it is denied AAAA records even if its client is using IPv6.

### 12.15.3 Options

#### **filter-aaaa**

This option specifies a list of client addresses for which AAAA filtering is to be applied. The default is `any`.

#### **filter-aaaa-on-v4**

If set to `yes`, this option indicates that the DNS client is at an IPv4 address, in `filter-aaaa`. If the response does not include DNSSEC signatures, then all AAAA records are deleted from the response. This filtering applies to all responses, not only authoritative ones.

If set to `break-dnssec`, then AAAA records are deleted even when DNSSEC is enabled. As suggested by the name, this causes the response to fail to verify, because the DNSSEC protocol is designed to detect deletions.

This mechanism can erroneously cause other servers not to give AAAA records to their clients. If a recursing server with both IPv6 and IPv4 network connections queries an authoritative server using this mechanism via IPv4, it is denied AAAA records even if its client is using IPv6.

#### **filter-aaaa-on-v6**

This option is identical to `filter-aaaa-on-v4`, except that it filters AAAA responses to queries from IPv6 clients instead of IPv4 clients. To filter all responses, set both options to `yes`.

## 12.15.4 See Also

BIND 9 Administrator Reference Manual.

## 12.16 host - DNS lookup utility

### 12.16.1 Synopsis

```
host [-aACdlrsTUwv] [-c class] [-N ndots] [-p port] [-R number] [-t type] [-W wait] [-m flag] [ [-4] | [-6] ] [-v] [-V]
{name} [server]
```

### 12.16.2 Description

**host** is a simple utility for performing DNS lookups. It is normally used to convert names to IP addresses and vice versa. When no arguments or options are given, **host** prints a short summary of its command-line arguments and options.

*name* is the domain name that is to be looked up. It can also be a dotted-decimal IPv4 address or a colon-delimited IPv6 address, in which case **host** by default performs a reverse lookup for that address. *server* is an optional argument which is either the name or IP address of the name server that **host** should query instead of the server or servers listed in `/etc/resolv.conf`.

### 12.16.3 Options

**-4**

This option specifies that only IPv4 should be used for query transport. See also the **-6** option.

**-6**

This option specifies that only IPv6 should be used for query transport. See also the **-4** option.

**-a**

The **-a** ("all") option is normally equivalent to **-v -t ANY**. It also affects the behavior of the **-l** list zone option.

**-A**

The **-A** ("almost all") option is equivalent to **-a**, except that RRSIG, NSEC, and NSEC3 records are omitted from the output.

**-c class**

This option specifies the query class, which can be used to lookup HS (Hesiod) or CH (Chaosnet) class resource records. The default class is IN (Internet).

**-c**

This option indicates that *named* should check consistency, meaning that **host** queries the SOA records for zone *name* from all the listed authoritative name servers for that zone. The list of name servers is defined by the NS records that are found for the zone.

**-d**

This option prints debugging traces, and is equivalent to the **-v** verbose option.

**-l**

This option tells *named* to list the zone, meaning the **host** command performs a zone transfer of zone *name* and prints out the NS, PTR, and address records (A/AAAA).

Together, the **-l -a** options print all records in the zone.

**-N** *ndots*

This option specifies the number of dots (*ndots*) that have to be in *name* for it to be considered absolute. The default value is that defined using the *ndots* statement in */etc/resolv.conf*, or 1 if no *ndots* statement is present. Names with fewer dots are interpreted as relative names, and are searched for in the domains listed in the *search* or *domain* directive in */etc/resolv.conf*.

**-p** *port*

This option specifies the port to query on the server. The default is 53.

**-r**

This option specifies a non-recursive query; setting this option clears the RD (recursion desired) bit in the query. This means that the name server receiving the query does not attempt to resolve *name*. The *-r* option enables **host** to mimic the behavior of a name server by making non-recursive queries, and expecting to receive answers to those queries that can be referrals to other name servers.

**-R** *number*

This option specifies the number of retries for UDP queries. If *number* is negative or zero, the number of retries is silently set to 1. The default value is 1, or the value of the *attempts* option in */etc/resolv.conf*, if set.

**-s**

This option tells *named* not to send the query to the next nameserver if any server responds with a SERVFAIL response, which is the reverse of normal stub resolver behavior.

**-t** *type*

This option specifies the query type. The *type* argument can be any recognized query type: CNAME, NS, SOA, TXT, DNSKEY, AXFR, etc.

When no query type is specified, **host** automatically selects an appropriate query type. By default, it looks for A, AAAA, and MX records. If the *-C* option is given, queries are made for SOA records. If *name* is a dotted-decimal IPv4 address or colon-delimited IPv6 address, **host** queries for PTR records.

If a query type of IXFR is chosen, the starting serial number can be specified by appending an equals sign (=), followed by the starting serial number, e.g., *-t IXFR=12345678*.

**-T, -U**

This option specifies TCP or UDP. By default, **host** uses UDP when making queries; the *-T* option makes it use a TCP connection when querying the name server. TCP is automatically selected for queries that require it, such as zone transfer (AXFR) requests. Type *ANY* queries default to TCP, but can be forced to use UDP initially via *-U*.

**-m** *flag*

This option sets memory usage debugging: the flag can be *record*, *usage*, or *trace*. The *-m* option can be specified more than once to set multiple flags.

**-v**

This option sets verbose output, and is equivalent to the *-d* debug option. Verbose output can also be enabled by setting the *debug* option in */etc/resolv.conf*.

**-V**

This option prints the version number and exits.

**-w**

This option sets "wait forever": the query timeout is set to the maximum possible. See also the *-W* option.

**-W** *wait*

This options sets the length of the wait timeout, indicating that *named* should wait for up to *wait* seconds for a reply. If *wait* is less than 1, the wait interval is set to 1 second.

By default, **host** waits for 5 seconds for UDP responses and 10 seconds for TCP connections. These defaults can be overridden by the `timeout` option in `/etc/resolv.conf`.

See also the `-w` option.

## 12.16.4 IDN Support

If **host** has been built with IDN (internationalized domain name) support, it can accept and display non-ASCII domain names. **host** appropriately converts character encoding of a domain name before sending a request to a DNS server or displaying a reply from the server. To turn off IDN support, define the `IDN_DISABLE` environment variable. IDN support is disabled if the variable is set when **host** runs.

## 12.16.5 Files

`/etc/resolv.conf`

## 12.16.6 See Also

`dig(1)`, `named(8)`.

# 12.17 mdig - DNS pipelined lookup utility

## 12.17.1 Synopsis

```
mdig {@server} [-f filename] [-h] [-v] [ [-4] | [-6] ] [-m] [-b address] [-p port#] [-c class] [-t type] [-i] [-x addr] [plusopt...]
```

```
mdig {-h}
```

```
mdig [@server] {global-opt...} { {local-opt...} {query} ...}
```

## 12.17.2 Description

**mdig** is a multiple/pipelined query version of *dig*: instead of waiting for a response after sending each query, it begins by sending all queries. Responses are displayed in the order in which they are received, not in the order the corresponding queries were sent.

**mdig** options are a subset of the *dig* options, and are divided into "anywhere options," which can occur anywhere, "global options," which must occur before the query name (or they are ignored with a warning), and "local options," which apply to the next query on the command line.

The *@server* option is a mandatory global option. It is the name or IP address of the name server to query. (Unlike *dig*, this value is not retrieved from `/etc/resolv.conf`.) It can be an IPv4 address in dotted-decimal notation, an IPv6 address in colon-delimited notation, or a hostname. When the supplied *server* argument is a hostname, **mdig** resolves that name before querying the name server.

**mdig** provides a number of query options which affect the way in which lookups are made and the results displayed. Some of these set or reset flag bits in the query header, some determine which sections of the answer get printed, and others determine the timeout and retry strategies.

Each query option is identified by a keyword preceded by a plus sign (+). Some keywords set or reset an option. These may be preceded by the string `no` to negate the meaning of that keyword. Other keywords assign values to options like the timeout interval. They have the form `+keyword=value`.

### 12.17.3 Anywhere Options

**-f**

This option makes **mdig** operate in batch mode by reading a list of lookup requests to process from the file `file-name`. The file contains a number of queries, one per line. Each entry in the file should be organized in the same way they would be presented as queries to **mdig** using the command-line interface.

**-h**

This option causes **mdig** to print detailed help information, with the full list of options, and exit.

**-v**

This option causes **mdig** to print the version number and exit.

### 12.17.4 Global Options

**-4**

This option forces **mdig** to only use IPv4 query transport.

**-6**

This option forces **mdig** to only use IPv6 query transport.

**-b** `address`

This option sets the source IP address of the query to `address`. This must be a valid address on one of the host's network interfaces or "0.0.0.0" or ":::". An optional port may be specified by appending "#<port>"

**-m**

This option enables memory usage debugging.

**-p** `port#`

This option is used when a non-standard port number is to be queried. `port#` is the port number that **mdig** sends its queries to, instead of the standard DNS port number 53. This option is used to test a name server that has been configured to listen for queries on a non-standard port number.

The global query options are:

**+additional, +noadditional**

This option displays [or does not display] the additional section of a reply. The default is to display it.

**+all, +noall**

This option sets or clears all display flags.

**+answer, +noanswer**

This option displays [or does not display] the answer section of a reply. The default is to display it.

**+authority, +noauthority**

This option displays [or does not display] the authority section of a reply. The default is to display it.

**+besteffort, +nobesteffort**

This option attempts to display [or does not display] the contents of messages which are malformed. The default is to not display malformed answers.

**+burst**

This option delays queries until the start of the next second.

**+cl, +nocl**

This option displays [or does not display] the CLASS when printing the record.

**+comments, +nocomments**

This option toggles the display of comment lines in the output. The default is to print comments.

**+continue, +nocontinue**

This option toggles continuation on errors (e.g. timeouts).

**+crypto, +nocrypto**

This option toggles the display of cryptographic fields in DNSSEC records. The contents of these fields are unnecessary to debug most DNSSEC validation failures and removing them makes it easier to see the common failures. The default is to display the fields. When omitted, they are replaced by the string "[omitted]"; in the DNSKEY case, the key ID is displayed as the replacement, e.g., [ key id = value ].

**+dscp=value**

This option formerly set the DSCP value used when sending a query. It is now obsolete, and has no effect.

**+multiline, +nomultiline**

This option toggles printing of records, like the SOA records, in a verbose multi-line format with human-readable comments. The default is to print each record on a single line, to facilitate machine parsing of the **mdig** output.

**+question, +noquestion**

This option prints [or does not print] the question section of a query when an answer is returned. The default is to print the question section as a comment.

**+rrcomments, +norrcomments**

This option toggles the display of per-record comments in the output (for example, human-readable key information about DNSKEY records). The default is not to print record comments unless multiline mode is active.

**+short, +noshort**

This option provides [or does not provide] a terse answer. The default is to print the answer in a verbose form.

**+split=W**

This option splits long hex- or base64-formatted fields in resource records into chunks of *W* characters (where *W* is rounded up to the nearest multiple of 4). **+nosplit** or **+split=0** causes fields not to be split. The default is 56 characters, or 44 characters when multiline mode is active.

**+tcp, +notcp**

This option uses [or does not use] TCP when querying name servers. The default behavior is to use UDP.

**+ttlid, +nottlid**

This option displays [or does not display] the TTL when printing the record.

**+ttlunits, +nottlunits**

This option displays [or does not display] the TTL in friendly human-readable time units of "s", "m", "h", "d", and "w", representing seconds, minutes, hours, days, and weeks. This implies **+ttlid**.

**+vc, +novc**

This option uses [or does not use] TCP when querying name servers. This alternate syntax to **+tcp** is provided for backwards compatibility. The **vc** stands for "virtual circuit".

## 12.17.5 Local Options

**-c class**

This option sets the query class to **class**. It can be any valid query class which is supported in BIND 9. The default query class is "IN".

**-t** *type*

This option sets the query type to *type*. It can be any valid query type which is supported in BIND 9. The default query type is "A", unless the **-x** option is supplied to indicate a reverse lookup with the "PTR" query type.

**-x** *addr*

Reverse lookups - mapping addresses to names - are simplified by this option. *addr* is an IPv4 address in dotted-decimal notation, or a colon-delimited IPv6 address. **mdig** automatically performs a lookup for a query name like `11.12.13.10.in-addr.arpa` and sets the query type and class to PTR and IN respectively. By default, IPv6 addresses are looked up using nibble format under the IP6.ARPA domain.

The local query options are:

**+aaflag, +noaflag**

This is a synonym for *+aaonly, +noaaonly*.

**+aaonly, +noaaonly**

This sets the *aa* flag in the query.

**+adflag, +noadflag**

This sets [or does not set] the AD (authentic data) bit in the query. This requests the server to return whether all of the answer and authority sections have all been validated as secure, according to the security policy of the server. AD=1 indicates that all records have been validated as secure and the answer is not from a OPT-OUT range. AD=0 indicates that some part of the answer was insecure or not validated. This bit is set by default.

**+bufsize=B**

This sets the UDP message buffer size advertised using EDNS0 to *B* bytes. The maximum and minimum sizes of this buffer are 65535 and 0 respectively. Values outside this range are rounded up or down appropriately. Values other than zero cause a EDNS query to be sent.

**+cdfflag, +nocdf**

This sets [or does not set] the CD (checking disabled) bit in the query. This requests the server to not perform DNSSEC validation of responses.

**+cookie=####, +nocookie**

This sends [or does not send] a COOKIE EDNS option, with an optional value. Replaying a COOKIE from a previous response allows the server to identify a previous client. The default is *+nocookie*.

**+dnssec, +nodnssec**

This requests that DNSSEC records be sent by setting the DNSSEC OK (DO) bit in the OPT record in the additional section of the query.

**+edns [=#], +noedns**

This specifies [or does not specify] the EDNS version to query with. Valid values are 0 to 255. Setting the EDNS version causes an EDNS query to be sent. *+noedns* clears the remembered EDNS version. EDNS is set to 0 by default.

**+ednsflags [=#], +noednsflags**

This sets the must-be-zero EDNS flag bits (Z bits) to the specified value. Decimal, hex, and octal encodings are accepted. Setting a named flag (e.g. DO) is silently ignored. By default, no Z bits are set.

**+ednsopt [=code[:value]], +noednsopt**

This specifies [or does not specify] an EDNS option with code point *code* and an optional payload of *value* as a hexadecimal string. *+noednsopt* clears the EDNS options to be sent.

**+expire, +noexpire**

This toggles sending of an EDNS Expire option.

**+nsid, +nonsid**

This toggles inclusion of an EDNS name server ID request when sending a query.

**+recurse, +norecurse**

This toggles the setting of the RD (recursion desired) bit in the query. This bit is set by default, which means **mdig** normally sends recursive queries.

**+retry=T**

This sets the number of times to retry UDP queries to server to **T** instead of the default, 2. Unlike *+tries*, this does not include the initial query.

**+subnet=addr[/prefix-length], +nosubnet**

This sends [or does not send] an EDNS Client Subnet option with the specified IP address or network prefix.

**mdig +subnet=0.0.0.0/0, or simply mdig +subnet=0**

This sends an EDNS client-subnet option with an empty address and a source prefix-length of zero, which signals a resolver that the client's address information must *not* be used when resolving this query.

**+timeout=T**

This sets the timeout for a query to **T** seconds. The default timeout is 5 seconds for UDP transport and 10 for TCP. An attempt to set **T** to less than 1 results in a query timeout of 1 second being applied.

**+tries=T**

This sets the number of times to try UDP queries to server to **T** instead of the default, 3. If **T** is less than or equal to zero, the number of tries is silently rounded up to 1.

**+udptimeout=T**

This sets the timeout between UDP query retries to **T**.

**+unknownformat, +nunknownformat**

This prints [or does not print] all RDATA in unknown RR-type presentation format (see [RFC 3597](#)). The default is to print RDATA for known types in the type's presentation format.

**+yaml, +noyaml**

This toggles printing of the responses in a detailed YAML format.

**+zflag, +nozflag**

This sets [or does not set] the last unassigned DNS header flag in a DNS query. This flag is off by default.

## 12.17.6 See Also

*dig(1)*, [RFC 1035](#).

## 12.18 named-checkconf - named configuration file syntax checking tool

### 12.18.1 Synopsis

```
named-checkconf [-chjlvz] [-p [-x ]] [-t directory] {filename}
```

### 12.18.2 Description

**named-checkconf** checks the syntax, but not the semantics, of a *named* configuration file. The file, along with all files included by it, is parsed and checked for syntax errors. If no file is specified, `/usr/local/etc/named.conf` is read by default.

Note: files that *named* reads in separate parser contexts, such as *rndc.key* and *bind.keys*, are not automatically read by **named-checkconf**. Configuration errors in these files may cause *named* to fail to run, even if **named-checkconf** was successful. However, **named-checkconf** can be run on these files explicitly.

### 12.18.3 Options

- h**  
This option prints the usage summary and exits.
  - j**  
When loading a zonefile, this option instructs *named* to read the journal if it exists.
  - l**  
This option lists all the configured zones. Each line of output contains the zone name, class (e.g. IN), view, and type (e.g. primary or secondary).
  - c**  
This option specifies that only the "core" configuration should be checked. This suppresses the loading of plugin modules, and causes all parameters to `plugin` statements to be ignored.
  - i**  
This option ignores warnings on deprecated options.
  - p**  
This option prints out the *named.conf* and included files in canonical form if no errors were detected. See also the `-x` option.
  - t** *directory*  
This option instructs *named* to chroot to *directory*, so that `include` directives in the configuration file are processed as if run by a similarly chrooted *named*.
  - v**  
This option prints the version of the **named-checkconf** program and exits.
  - x**  
When printing the configuration files in canonical form, this option obscures shared secrets by replacing them with strings of question marks (?). This allows the contents of *named.conf* and related files to be shared - for example, when submitting bug reports - without compromising private data. This option cannot be used without `-p`.
  - z**  
This option performs a test load of all zones of type `primary` found in *named.conf*.
- filename**  
This indicates the name of the configuration file to be checked. If not specified, it defaults to `/usr/local/etc/named.conf`.

### 12.18.4 Return Values

**named-checkconf** returns an exit status of 1 if errors were detected and 0 otherwise.

### 12.18.5 See Also

*named(8)*, *named-checkzone(8)*, BIND 9 Administrator Reference Manual.

## 12.19 named-checkzone - zone file validation tool

### 12.19.1 Synopsis

**named-checkzone** [-d] [-h] [-j] [-q] [-v] [-c class] [-f format] [-F format] [-J filename] [-i mode] [-k mode] [-m mode] [-M mode] [-n mode] [-l ttl] [-L serial] [-o filename] [-r mode] [-s style] [-S mode] [-t directory] [-T mode] [-w directory] [-D] [-W mode] {zonename} {filename}

### 12.19.2 Description

**named-checkzone** checks the syntax and integrity of a zone file. It performs the same checks as *named* does when loading a zone. This makes **named-checkzone** useful for checking zone files before configuring them into a name server.

### 12.19.3 Options

**-d**

This option enables debugging.

**-h**

This option prints the usage summary and exits.

**-q**

This option sets quiet mode, which only sets an exit code to indicate successful or failed completion.

**-v**

This option prints the version of the **named-checkzone** program and exits.

**-j**

When loading a zone file, this option tells *named* to read the journal if it exists. The journal file name is assumed to be the zone file name with the string `.jnl` appended.

**-J filename**

When loading the zone file, this option tells *named* to read the journal from the given file, if it exists. This implies `-j`.

**-c class**

This option specifies the class of the zone. If not specified, `IN` is assumed.

**-i mode**

This option performs post-load zone integrity checks. Possible modes are `full` (the default), `full-sibling`, `local`, `local-sibling`, and `none`.

Mode `full` checks that MX records refer to A or AAAA records (both in-zone and out-of-zone hostnames). Mode `local` only checks MX records which refer to in-zone hostnames.

Mode `full` checks that SRV records refer to A or AAAA records (both in-zone and out-of-zone hostnames). Mode `local` only checks SRV records which refer to in-zone hostnames.

Mode `full` checks that delegation NS records refer to A or AAAA records (both in-zone and out-of-zone hostnames). It also checks that glue address records in the zone match those advertised by the child. Mode `local` only checks NS records which refer to in-zone hostnames or verifies that some required glue exists, i.e., when the name server is in a child zone.

Modes `full-sibling` and `local-sibling` disable sibling glue checks, but are otherwise the same as `full` and `local`, respectively.

Mode `none` disables the checks.

- f** format  
This option specifies the format of the zone file. Possible formats are `text` (the default), and `raw`.
- F** format  
This option specifies the format of the output file specified. For `named-checkzone`, this does not have any effect unless it dumps the zone contents.  
  
Possible formats are `text` (the default), which is the standard textual representation of the zone, and `raw` and `raw=N`, which store the zone in a binary format for rapid loading by `named`. `raw=N` specifies the format version of the raw zone file: if N is 0, the raw file can be read by any version of `named`; if N is 1, the file can only be read by release 9.9.0 or higher. The default is 1.
- k** mode  
This option performs `check-names` checks with the specified failure mode. Possible modes are `fail`, `warn` (the default), and `ignore`.
- l** ttl  
This option sets a maximum permissible TTL for the input file. Any record with a TTL higher than this value causes the zone to be rejected. This is similar to using the `max-zone-ttl` option in `named.conf`.
- L** serial  
When compiling a zone to `raw` format, this option sets the "source serial" value in the header to the specified serial number. This is expected to be used primarily for testing purposes.
- m** mode  
This option specifies whether MX records should be checked to see if they are addresses. Possible modes are `fail`, `warn` (the default), and `ignore`.
- M** mode  
This option checks whether a MX record refers to a CNAME. Possible modes are `fail`, `warn` (the default), and `ignore`.
- n** mode  
This option specifies whether NS records should be checked to see if they are addresses. Possible modes are `fail`, `warn` (the default), and `ignore`.
- o** filename  
This option writes the zone output to `filename`. If `filename` is `-`, then the zone output is written to standard output.
- r** mode  
This option checks for records that are treated as different by DNSSEC but are semantically equal in plain DNS. Possible modes are `fail`, `warn` (the default), and `ignore`.
- s** style  
This option specifies the style of the dumped zone file. Possible styles are `full` (the default) and `relative`. The `full` format is most suitable for processing automatically by a separate script. The `relative` format is more human-readable and is thus suitable for editing by hand. This does not have any effect unless it dumps the zone contents. It also does not have any meaning if the output format is not text.
- S** mode  
This option checks whether an SRV record refers to a CNAME. Possible modes are `fail`, `warn` (the default), and `ignore`.
- t** directory  
This option tells `named` to chroot to `directory`, so that `include` directives in the configuration file are processed as if run by a similarly chrooted `named`.

**-T** mode

This option checks whether Sender Policy Framework (SPF) records exist and issues a warning if an SPF-formatted TXT record is not also present. Possible modes are `warn` (the default) and `ignore`.

**-w** directory

This option instructs `named` to `chdir` to `directory`, so that relative filenames in master file `$INCLUDE` directives work. This is similar to the `directory` clause in `named.conf`.

**-D**

This option dumps the zone file in canonical format.

**-W** mode

This option specifies whether to check for non-terminal wildcards. Non-terminal wildcards are almost always the result of a failure to understand the wildcard matching algorithm ([RFC 4592](#)). Possible modes are `warn` (the default) and `ignore`.

**zonename**

This indicates the domain name of the zone being checked.

**filename**

This is the name of the zone file.

## 12.19.4 Return Values

`named-checkzone` returns an exit status of 1 if errors were detected and 0 otherwise.

## 12.19.5 See Also

`named(8)`, `named-checkconf(8)`, `named-compilezone(8)`, [RFC 1035](#), BIND 9 Administrator Reference Manual.

## 12.20 named-compilezone - zone file converting tool

### 12.20.1 Synopsis

```
named-compilezone [-d] [-h] [-j] [-q] [-v] [-c class] [-f format] [-F format] [-J filename] [-i mode] [-k mode] [-m mode] [-M mode] [-n mode] [-l ttl] [-L serial] [-r mode] [-s style] [-S mode] [-t directory] [-T mode] [-w directory] [-D] [-W mode] {-o filename} {zonename} {filename}
```

### 12.20.2 Description

`named-compilezone` checks the syntax and integrity of a zone file, and dumps the zone contents to a specified file in a specified format. It applies strict check levels by default, since the dump output is used as an actual zone file loaded by `named`. When manually specified otherwise, the check levels must at least be as strict as those specified in the `named` configuration file.

### 12.20.3 Options

**-d**

This option enables debugging.

**-h**

This option prints the usage summary and exits.

- q** This option sets quiet mode, which only sets an exit code to indicate successful or failed completion.
- v** This option prints the version of the *named-checkzone* program and exits.
- j** When loading a zone file, this option tells *named* to read the journal if it exists. The journal file name is assumed to be the zone file name with the string *.jnl* appended.
- J filename** When loading the zone file, this option tells *named* to read the journal from the given file, if it exists. This implies *-j*.
- c class** This option specifies the class of the zone. If not specified, *IN* is assumed.
- i mode** This option performs post-load zone integrity checks. Possible modes are *full* (the default), *full-sibling*, *local*, *local-sibling*, and *none*.
- Mode *full* checks that MX records refer to A or AAAA records (both in-zone and out-of-zone hostnames). Mode *local* only checks MX records which refer to in-zone hostnames.
- Mode *full* checks that SRV records refer to A or AAAA records (both in-zone and out-of-zone hostnames). Mode *local* only checks SRV records which refer to in-zone hostnames.
- Mode *full* checks that delegation NS records refer to A or AAAA records (both in-zone and out-of-zone hostnames). It also checks that glue address records in the zone match those advertised by the child. Mode *local* only checks NS records which refer to in-zone hostnames or verifies that some required glue exists, i.e., when the name server is in a child zone.
- Modes *full-sibling* and *local-sibling* disable sibling glue checks, but are otherwise the same as *full* and *local*, respectively.
- Mode *none* disables the checks.
- f format** This option specifies the format of the zone file. Possible formats are *text* (the default), and *raw*.
- F format** This option specifies the format of the output file specified. For *named-checkzone*, this does not have any effect unless it dumps the zone contents.
- Possible formats are *text* (the default), which is the standard textual representation of the zone, and *raw* and *raw=N*, which store the zone in a binary format for rapid loading by *named*. *raw=N* specifies the format version of the raw zone file: if *N* is 0, the raw file can be read by any version of *named*; if *N* is 1, the file can only be read by release 9.9.0 or higher. The default is 1.
- k mode** This option performs *check-names* checks with the specified failure mode. Possible modes are *fail* (the default), *warn*, and *ignore*.
- l ttl** This option sets a maximum permissible TTL for the input file. Any record with a TTL higher than this value causes the zone to be rejected. This is similar to using the *max-zone-ttl* option in *named.conf*.

- l** *serial*  
When compiling a zone to `raw` format, this option sets the "source serial" value in the header to the specified serial number. This is expected to be used primarily for testing purposes.
  - m** *mode*  
This option specifies whether MX records should be checked to see if they are addresses. Possible modes are `fail`, `warn` (the default), and `ignore`.
  - M** *mode*  
This option checks whether a MX record refers to a CNAME. Possible modes are `fail`, `warn` (the default), and `ignore`.
  - n** *mode*  
This option specifies whether NS records should be checked to see if they are addresses. Possible modes are `fail` (the default), `warn`, and `ignore`.
  - o** *filename*  
This option writes the zone output to `filename`. If `filename` is `-`, then the zone output is written to standard output. This is mandatory for `named-compilezone`.
  - r** *mode*  
This option checks for records that are treated as different by DNSSEC but are semantically equal in plain DNS. Possible modes are `fail`, `warn` (the default), and `ignore`.
  - s** *style*  
This option specifies the style of the dumped zone file. Possible styles are `full` (the default) and `relative`. The `full` format is most suitable for processing automatically by a separate script. The `relative` format is more human-readable and is thus suitable for editing by hand.
  - S** *mode*  
This option checks whether an SRV record refers to a CNAME. Possible modes are `fail`, `warn` (the default), and `ignore`.
  - t** *directory*  
This option tells `named` to chroot to `directory`, so that `include` directives in the configuration file are processed as if run by a similarly chrooted `named`.
  - T** *mode*  
This option checks whether Sender Policy Framework (SPF) records exist and issues a warning if an SPF-formatted TXT record is not also present. Possible modes are `warn` (the default) and `ignore`.
  - w** *directory*  
This option instructs `named` to `chdir` to `directory`, so that relative filenames in master file `$INCLUDE` directives work. This is similar to the `directory` clause in `named.conf`.
  - D**  
This option dumps the zone file in canonical format. This is always enabled for `named-compilezone`.
  - W** *mode*  
This option specifies whether to check for non-terminal wildcards. Non-terminal wildcards are almost always the result of a failure to understand the wildcard matching algorithm ([RFC 4592](#)). Possible modes are `warn` (the default) and `ignore`.
- zonename**  
This indicates the domain name of the zone being checked.
- filename**  
This is the name of the zone file.

## 12.20.4 Return Values

`named-compilezone` returns an exit status of 1 if errors were detected and 0 otherwise.

## 12.20.5 See Also

*named(8)*, *named-checkconf(8)*, *named-checkzone(8)*, [RFC 1035](#), BIND 9 Administrator Reference Manual.

# 12.21 named-journalprint - print zone journal in human-readable form

## 12.21.1 Synopsis

```
named-journalprint [-c serial] [-dux] {journal}
```

## 12.21.2 Description

`named-journalprint` scans the contents of a zone journal file, printing it in a human-readable form, or, optionally, converting it to a different journal file format.

Journal files are automatically created by *named* when changes are made to dynamic zones (e.g., by *nsupdate*). They record each addition or deletion of a resource record, in binary format, allowing the changes to be re-applied to the zone when the server is restarted after a shutdown or crash. By default, the name of the journal file is formed by appending the extension `.jnl` to the name of the corresponding zone file.

`named-journalprint` converts the contents of a given journal file into a human-readable text format. Each line begins with `add` or `del`, to indicate whether the record was added or deleted, and continues with the resource record in master-file format.

The `-c` (compact) option provides a mechanism to reduce the size of a journal by removing (most/all) transactions prior to the specified serial number. Note: this option *must not* be used while *named* is running, and can cause data loss if the zone file has not been updated to contain the data being removed from the journal. Use with extreme caution.

The `-x` option causes additional data about the journal file to be printed at the beginning of the output and before each group of changes.

The `-u` (upgrade) and `-d` (downgrade) options recreate the journal file with a modified format version. The existing journal file is replaced. `-d` writes out the journal in the format used by versions of BIND up to 9.16.11; `-u` writes it out in the format used by versions since 9.16.13. (9.16.12 is omitted due to a journal-formatting bug in that release.) Note that these options *must not* be used while *named* is running.

## 12.21.3 See Also

*named(8)*, *nsupdate(1)*, BIND 9 Administrator Reference Manual.

# 12.22 named-nzd2nzf - convert an NZD database to NZF text format

## 12.22.1 Synopsis

```
named-nzd2nzf {filename}
```

## 12.22.2 Description

`named-nzd2nzf` converts an NZD database to NZF format and prints it to standard output. This can be used to review the configuration of zones that were added to *named* via *rndc addzone*. It can also be used to restore the old file format when rolling back from a newer version of BIND to an older version.

### 12.22.3 Arguments

**filename**

This is the name of the `.nzd` file whose contents should be printed.

### 12.22.4 See Also

BIND 9 Administrator Reference Manual.

## 12.23 `named-rrchecker` - syntax checker for individual DNS resource records

### 12.23.1 Synopsis

```
named-rrchecker [-h] [-o origin] [-p] [-u] [-C] [-T] [-P]
```

### 12.23.2 Description

`named-rrchecker` reads a single DNS resource record (RR) from standard input and checks whether it is syntactically correct.

**The input format is a minimal subset of the DNS zone file format. The entire input must be:**

```
CLASS TYPE RDATA
```

- Input must not start with an owner (domain) name
- The *CLASS* field is mandatory (typically `IN`).
- The *TTL* field **must not** be present.
- RDATA format is specific to each RRTYPE.
- Leading and trailing whitespace in each field is ignored.

Format details can be found in [RFC 1035 Section 5.1](#) under `<rr>` specification. [RFC 3597](#) format is also accepted in any of the input fields. See *Examples*.

### 12.23.3 Options

**-o origin**

This option specifies the origin to be used when interpreting names in the record: it defaults to root (`.`). The specified origin is always taken as an absolute name.

**-p**

This option prints out the resulting record in canonical form. If there is no canonical form defined, the record is printed in [RFC 3597](#) unknown record format.

**-u**

This option prints out the resulting record in [RFC 3597](#) unknown record format.

**-C, -T, -P**

These options do not read input. They print out known classes, standard types, and private type mnemonics. Each item is printed on a separate line. The resulting list of private types may be empty

**-h**

This option prints out the help menu.

## 12.23.4 Examples

Pay close attention to the `echo` command line options `-e` and `-n`, as they affect whitespace in the input to `named-rrchecker`.

**echo -n 'IN A 192.0.2.1' | named-rrchecker**

- Valid input is in **RFC 1035** format with no newline at the end of the input.
- Return code 0.

**echo -e '\n\nIN A 192.0.2.1\t\n\n' | named-rrchecker -p**

- Valid input with leading and trailing whitespace.
- Output: `IN A 192.0.2.1`
- Leading and trailing whitespace is not part of the output.

### Relative names and origin

**echo 'IN CNAME target' | named-rrchecker -p**

- Valid input with a relative name as the CNAME target.
- Output: `IN CNAME target.`
- Relative name *target* from the input is converted to an absolute name using the default origin `.` (root).

**echo 'IN CNAME target' | named-rrchecker -p -o origin.test**

- Valid input with a relative name as the CNAME target.
- Output: `IN CNAME target.origin.test.`
- Relative name *target* from the input is converted to an absolute name using the specified origin `origin.test`

**echo 'IN CNAME target.' | named-rrchecker -p -o origin.test**

- Valid input with an absolute name as the CNAME target.
- Output: `IN CNAME target.`
- The specified origin has no influence if *target* from the input is already absolute.

### Special characters

Special characters allowed in zone files by **RFC 1035 Section 5.1** are accepted.

**echo 'IN CNAME t\097r\get\.' | named-rrchecker -p -o origin.test**

- Valid input with backslash escapes.
- Output: `IN CNAME target\..origin.test.`
- `\097` denotes an ASCII value in decimal, which, in this example, is the character `a`.
- `\g` is converted to a plain `g` because the `g` character does not have a special meaning and so the `\` prefix does nothing in this case.
- `\.` denotes a literal ASCII dot (here as a part of the CNAME target name). Special meaning of `.` as the DNS label separator was disabled by the preceding `\` prefix.

**echo 'IN CNAME @' | named-rrchecker -p -o origin.test**

- Valid input with `@` used as a reference to the specified origin.
- Output: `IN CNAME origin.test.`

**echo 'IN CNAME \@' | named-rrchecker -p -o origin.test**

- Valid input with a literal @ character (escaped).
- Output: IN CNAME \@.origin.test.

**echo 'IN CNAME prefix.@' | named-rrchecker -p -o origin.test**

- Valid input with @ used as a reference to the specified origin.
- Output: IN CNAME prefix.\@.origin.test.
- @ has special meaning only if it is free-standing.

**echo 'IN A 192.0.2.1; comment' | named-rrchecker -p**

- Valid input with a trailing comment. Note the lack of whitespace before the start of the comment.
- Output: IN A 192.0.2.1

For multi-line examples see the next section.

**Multi-token records****echo -e 'IN TXT two words \n' | named-rrchecker -p**

- Valid TXT RR with two unquoted words and trailing whitespace.
- Output: IN TXT "two" "words"
- Two unquoted words in the input are treated as two *<character-string>*s per [RFC 1035 Section 3.3.14](#).
- Trailing whitespace is omitted from the last *<character-string>*.

**echo -e 'IN TXT "two words" \n' | named-rrchecker -p**

- Valid TXT RR with one *character-string* and trailing whitespace.
- Output: IN TXT "two words"

**echo -e 'IN TXT "problematic newline\n"' | named-rrchecker -p**

- Invalid input - the closing " is not detected before the end of the line.

**echo 'IN TXT "with newline\010"' | named-rrchecker -p**

- Valid input with an escaped newline character inside *character-string*.
- Output: IN TXT "with newline\010"

**echo -e 'IN TXT ( two\nwords )' | named-rrchecker -p**

- Valid multi-line input with line continuation allowed inside optional parentheses in the RDATA field.
- Output: IN TXT "two" "words"

**echo -e 'IN TXT ( two\nwords ; misplaced comment )' | named-rrchecker -p**

- Invalid input - comments, starting with ";", are ignored by the parser, so the closing parenthesis should be before the semicolon.

**echo -e 'IN TXT ( two\nwords ; a working comment\n )' | named-rrchecker -p**

- Valid input - the comment is terminated with a newline.
- Output: IN TXT "two" "words"

**echo 'IN HTTPS 1 . alpn="h2,h3"' | named-rrchecker -p**

- Valid HTTPS record

- Output: IN HTTPS 1 . alpn="h2,h3"

**echo -e 'IN HTTPS ( 1 \n . \n alpn="dot")port=853' | named-rrchecker -p**

- Valid HTTPS record with individual sub-fields split across multiple lines using [RFC 1035 Section 5.1](#) parentheses syntax to group data that crosses a line boundary.
- Note the missing whitespace between the closing parenthesis and adjacent tokens.
- Output: IN HTTPS 1 . alpn="dot" port=853

### Unknown type handling

**echo 'IN A 192.0.2.1' | named-rrchecker -u**

- Valid input in [RFC 1035](#) format.
- Output in [RFC 3957](#) format: CLASS1 TYPE1 \# 4 C0000201

**echo 'CLASS1 TYPE1 \# 4 C0000201' | named-rrchecker -p**

- Valid input in [RFC 3597](#) format.
- Output in [RFC 1035](#) format: IN A 192.0.2.1

**echo 'IN A \# 4 C0000201' | named-rrchecker -p**

- Valid input with class and type in [RFC 1035](#) format and rdata in [RFC 3597](#) format.
- Output in [RFC 1035](#) format: IN A 192.0.2.1

**echo 'IN HTTPS 1 . key3=\001\000' | named-rrchecker -p**

- Valid input with [RFC 9460](#) syntax for an unknown *key3* field. Syntax `\001\000` produces two octets with values 1 and 0, respectively.
- Output: IN HTTPS 1 . port=256
- *key3* matches the standardized key name *port*.
- Octets 1 and 0 were decoded as integer values in big-endian encoding.

**echo 'IN HTTPS 1 . key3=\001' | named-rrchecker -p**

- Invalid input - the length of the value for *key3* (i.e. *port*) does not match the known standard format for that parameter in the SVCB RRTYPE.

**echo 'IN HTTPS 1 . port=\001\000' | named-rrchecker -p**

- Invalid input - the key *port*, when specified using its standard mnemonic name, **must** use standard key-specific syntax.

### Meta values

**echo 'IN AXFR' | named-rrchecker**

- Invalid input - AXFR is a meta type, not a genuine RRTYPE.

**echo 'ANY A 192.0.2.1' | named-rrchecker**

- Invalid input - ANY is meta class, not a true class.

**echo 'A 192.0.2.1' | named-rrchecker**

- Invalid input - the class field is missing, so the parser would try and fail to interpret the RRTYPE A as the class.

## 12.23.5 Return Codes

**0**

The whole input was parsed as one syntactically valid resource record.

**1**

The input is not a syntactically valid resource record, or the given type is not supported, or either/both class and type are meta-values, which should not appear in zone files.

## 12.23.6 See Also

[RFC 1034](#), [RFC 1035](#), [RFC 3957](#), *named(8)*.

## 12.24 named.conf - configuration file for named

### 12.24.1 Synopsis

`named.conf`

### 12.24.2 Description

`named.conf` is the configuration file for *named*.

For complete documentation about the configuration statements, please refer to the Configuration Reference section in the BIND 9 Administrator Reference Manual.

Statements are enclosed in braces and terminated with a semi-colon. Clauses in the statements are also semi-colon terminated. The usual comment styles are supported:

C style: `/* */`

C++ style: `//` to end of line

Unix style: `#` to end of line

```
acl <string> { <address_match_element>; ... }; // may occur multiple times

controls {
    inet ( <ipv4_address> | <ipv6_address> | * ) [ port ( <integer> | * ) ] allow
    ↪{ <address_match_element>; ... } [ keys { <string>; ... } ] [ read-only <boolean> ];
    ↪ // may occur multiple times
    unix <quoted_string> perm <integer> owner <integer> group <integer> [ keys {
    ↪<string>; ... } ] [ read-only <boolean> ]; // may occur multiple times
}; // may occur multiple times

dlz <string> {
    database <string>;
    search <boolean>;
}; // may occur multiple times

dnssec-policy <string> {
    dnskey-ttl <duration>;
    keys ( ( csk | ksk | zsk ) [ ( key-directory ) ] lifetime <duration_or_
    ↪unlimited> algorithm <string> [ <integer> ]; ... );
    max-zone-ttl <duration>;
    nsec3param [ iterations <integer> ] [ optout <boolean> ] [ salt-length
```

(continues on next page)

(continued from previous page)

```

↳<integer> ];
    parent-ds-ttl <duration>;
    parent-propagation-delay <duration>;
    parent-registration-delay <duration>; // obsolete
    publish-safety <duration>;
    purge-keys <duration>;
    retire-safety <duration>;
    signatures-jitter <duration>;
    signatures-refresh <duration>;
    signatures-validity <duration>;
    signatures-validity-dnskey <duration>;
    zone-propagation-delay <duration>;
}; // may occur multiple times

dyndb <string> <quoted_string> { <unspecified-text> }; // may occur multiple times

http <string> {
    endpoints { <quoted_string>; ... };
    listener-clients <integer>;
    streams-per-connection <integer>;
}; // may occur multiple times

key <string> {
    algorithm <string>;
    secret <string>;
}; // may occur multiple times

logging {
    category <string> { <string>; ... }; // may occur multiple times
    channel <string> {
        buffered <boolean>;
        file <quoted_string> [ versions ( unlimited | <integer> ) ] [ size
↳<size> ] [ suffix ( increment | timestamp ) ];
        null;
        print-category <boolean>;
        print-severity <boolean>;
        print-time ( iso8601 | iso8601-utc | local | <boolean> );
        severity <log_severity>;
        stderr;
        syslog [ <syslog_facility> ];
    }; // may occur multiple times
};

managed-keys { <string> ( static-key | initial-key | static-ds | initial-ds )
↳<integer> <integer> <integer> <quoted_string>; ... }; // may occur multiple times,↳
↳deprecated

options {
    allow-new-zones <boolean>;
    allow-notify { <address_match_element>; ... };
    allow-query { <address_match_element>; ... };
    allow-query-cache { <address_match_element>; ... };

```

(continues on next page)

(continued from previous page)

```

allow-query-cache-on { <address_match_element>; ... };
allow-query-on { <address_match_element>; ... };
allow-recursion { <address_match_element>; ... };
allow-recursion-on { <address_match_element>; ... };
allow-transfer [ port <integer> ] [ transport <string> ] { <address_match_
↪element>; ... };
allow-update { <address_match_element>; ... };
allow-update-forwarding { <address_match_element>; ... };
also-notify [ port <integer> ] { ( <remote-servers> | <ipv4_address> [ port
↪<integer> ] | <ipv6_address> [ port <integer> ] ) [ key <string> ] [ tls <string> ];
↪ ... };
alt-transfer-source ( <ipv4_address> | * ) ; // deprecated
alt-transfer-source-v6 ( <ipv6_address> | * ) ; // deprecated
answer-cookie <boolean>;
attach-cache <string>;
auth-nxdomain <boolean>;
auto-dnssec ( allow | maintain | off ); // deprecated
automatic-interface-scan <boolean>;
avoid-v4-udp-ports { <portrange>; ... }; // deprecated
avoid-v6-udp-ports { <portrange>; ... }; // deprecated
bindkeys-file <quoted_string>;
blackhole { <address_match_element>; ... };
catalog-zones { zone <string> [ default-primaries [ port <integer> ] { (
↪<remote-servers> | <ipv4_address> [ port <integer> ] | <ipv6_address> [ port
↪<integer> ] ) [ key <string> ] [ tls <string> ]; ... } ] [ zone-directory <quoted_
↪string> ] [ in-memory <boolean> ] [ min-update-interval <duration> ]; ... };
check-dup-records ( fail | warn | ignore );
check-integrity <boolean>;
check-mx ( fail | warn | ignore );
check-mx-cname ( fail | warn | ignore );
check-names ( primary | master | secondary | slave | response ) ( fail | warn_
↪| ignore ); // may occur multiple times
check-sibling <boolean>;
check-spf ( warn | ignore );
check-srv-cname ( fail | warn | ignore );
check-wildcard <boolean>;
clients-per-query <integer>;
cookie-algorithm ( aes | siphash24 );
cookie-secret <string>; // may occur multiple times
coresize ( default | unlimited | <sizeval> ); // deprecated
datasize ( default | unlimited | <sizeval> ); // deprecated
deny-answer-addresses { <address_match_element>; ... } [ except-from {
↪<string>; ... } ];
deny-answer-aliases { <string>; ... } [ except-from { <string>; ... } ];
dialup ( notify | notify-passive | passive | refresh | <boolean> ); //_
↪deprecated
directory <quoted_string>;
disable-algorithms <string> { <string>; ... }; // may occur multiple times
disable-ds-digests <string> { <string>; ... }; // may occur multiple times
disable-empty-zone <string>; // may occur multiple times
dns64 <netprefix> {
    break-dnssec <boolean>;

```

(continues on next page)

(continued from previous page)

```

        clients { <address_match_element>; ... };
        exclude { <address_match_element>; ... };
        mapped { <address_match_element>; ... };
        recursive-only <boolean>;
        suffix <ipv6_address>;
}; // may occur multiple times
dns64-contact <string>;
dns64-server <string>;
dnskey-sig-validity <integer>;
dnssrps-enable <boolean>; // not configured
dnssrps-options { <unspecified-text> }; // not configured
dnssec-accept-expired <boolean>;
dnssec-dnskey-kskonly <boolean>;
dnssec-loadkeys-interval <integer>;
dnssec-must-be-secure <string> <boolean>; // may occur multiple times,
↳ deprecated
dnssec-policy <string>;
dnssec-secure-to-insecure <boolean>;
dnssec-update-mode ( maintain | no-resign );
dnssec-validation ( yes | no | auto );
dnstap { ( all | auth | client | forwarder | resolver | update ) [ ( query |
↳ response ) ]; ... }; // not configured
dnstap-identity ( <quoted_string> | none | hostname ); // not configured
dnstap-output ( file | unix ) <quoted_string> [ size ( unlimited | <size> ) ]
↳ [ versions ( unlimited | <integer> ) ] [ suffix ( increment | timestamp ) ]; // not
↳ configured
dnstap-version ( <quoted_string> | none ); // not configured
dscp <integer>; // obsolete
dual-stack-servers [ port <integer> ] { ( <quoted_string> [ port <integer> ]
↳ | <ipv4_address> [ port <integer> ] | <ipv6_address> [ port <integer> ] ); ... };
dump-file <quoted_string>;
edns-udp-size <integer>;
empty-contact <string>;
empty-server <string>;
empty-zones-enable <boolean>;
fetch-quota-params <integer> <fixedpoint> <fixedpoint> <fixedpoint>;
fetches-per-server <integer> [ ( drop | fail ) ];
fetches-per-zone <integer> [ ( drop | fail ) ];
files ( default | unlimited | <sizeval> ); // deprecated
flush-zones-on-shutdown <boolean>;
forward ( first | only );
forwarders [ port <integer> ] { ( <ipv4_address> | <ipv6_address> ) [ port
↳ <integer> ]; ... };
fstrm-set-buffer-hint <integer>; // not configured
fstrm-set-flush-timeout <integer>; // not configured
fstrm-set-input-queue-size <integer>; // not configured
fstrm-set-output-notify-threshold <integer>; // not configured
fstrm-set-output-queue-model ( mpsc | spsc ); // not configured
fstrm-set-output-queue-size <integer>; // not configured
fstrm-set-reopen-interval <duration>; // not configured
geoip-directory ( <quoted_string> | none );
glue-cache <boolean>; // deprecated

```

(continues on next page)

(continued from previous page)

```

heartbeat-interval <integer>; // deprecated
hostname ( <quoted_string> | none );
http-listener-clients <integer>;
http-port <integer>;
http-streams-per-connection <integer>;
https-port <integer>;
interface-interval <duration>;
ipv4only-contact <string>;
ipv4only-enable <boolean>;
ipv4only-server <string>;
ixfr-from-differences ( primary | master | secondary | slave | <boolean> );
keep-response-order { <address_match_element>; ... };
key-directory <quoted_string>;
lame-ttl <duration>;
listen-on [ port <integer> ] [ tls <string> ] [ http <string> ] { <address_
↔match_element>; ... }; // may occur multiple times
listen-on-v6 [ port <integer> ] [ tls <string> ] [ http <string> ] { <address_
↔match_element>; ... }; // may occur multiple times
lmdb-mapsize <sizeval>;
lock-file ( <quoted_string> | none );
managed-keys-directory <quoted_string>;
masterfile-format ( raw | text );
masterfile-style ( full | relative );
match-mapped-addresses <boolean>;
max-cache-size ( default | unlimited | <sizeval> | <percentage> );
max-cache-ttl <duration>;
max-clients-per-query <integer>;
max-ixfr-ratio ( unlimited | <percentage> );
max-journal-size ( default | unlimited | <sizeval> );
max-ncache-ttl <duration>;
max-query-count <integer>;
max-query-restarts <integer>;
max-records <integer>;
max-records-per-type <integer>;
max-recursion-depth <integer>;
max-recursion-queries <integer>;
max-refresh-time <integer>;
max-retry-time <integer>;
max-rsa-exponent-size <integer>;
max-stale-ttl <duration>;
max-transfer-idle-in <integer>;
max-transfer-idle-out <integer>;
max-transfer-time-in <integer>;
max-transfer-time-out <integer>;
max-types-per-name <integer>;
max-udp-size <integer>;
max-zone-ttl ( unlimited | <duration> );
memstatistics <boolean>;
memstatistics-file <quoted_string>;
message-compression <boolean>;
min-cache-ttl <duration>;
min-ncache-ttl <duration>;

```

(continues on next page)

(continued from previous page)

```

min-refresh-time <integer>;
min-retry-time <integer>;
minimal-any <boolean>;
minimal-responses ( no-auth | no-auth-recursive | <boolean> );
multi-master <boolean>;
new-zones-directory <quoted_string>;
no-case-compress { <address_match_element>; ... };
nocookie-udp-size <integer>;
notify ( explicit | master-only | primary-only | <boolean> );
notify-delay <integer>;
notify-rate <integer>;
notify-source ( <ipv4_address> | * ) ;
notify-source-v6 ( <ipv6_address> | * ) ;
notify-to-soa <boolean>;
nsec3-test-zone <boolean>; // test only
nta-lifetime <duration>;
nta-recheck <duration>;
nxdomain-redirect <string>;
parental-source ( <ipv4_address> | * ) ;
parental-source-v6 ( <ipv6_address> | * ) ;
pid-file ( <quoted_string> | none );
port <integer>;
preferred-glue <string>;
prefetch <integer> [ <integer> ];
provide-ixfr <boolean>;
qname-minimization ( strict | relaxed | disabled | off );
query-source [ address ] ( <ipv4_address> | * );
query-source-v6 [ address ] ( <ipv6_address> | * );
querylog <boolean>;
random-device ( <quoted_string> | none ); // obsolete
rate-limit {
    all-per-second <integer>;
    errors-per-second <integer>;
    exempt-clients { <address_match_element>; ... };
    ipv4-prefix-length <integer>;
    ipv6-prefix-length <integer>;
    log-only <boolean>;
    max-table-size <integer>;
    min-table-size <integer>;
    nodata-per-second <integer>;
    nxdomains-per-second <integer>;
    qps-scale <integer>;
    referrals-per-second <integer>;
    responses-per-second <integer>;
    slip <integer>;
    window <integer>;
};
recursing-file <quoted_string>;
recursion <boolean>;
recursive-clients <integer>;
request-expire <boolean>;
request-ixfr <boolean>;

```

(continues on next page)

(continued from previous page)

```

request-nsid <boolean>;
require-server-cookie <boolean>;
reserved-sockets <integer>; // deprecated
resolver-nonbackoff-tries <integer>; // deprecated
resolver-query-timeout <integer>;
resolver-retry-interval <integer>; // deprecated
response-padding { <address_match_element>; ... } block-size <integer>;
response-policy { zone <string> [ add-soa <boolean> ] [ log <boolean> ] [ max-
↳policy-ttl <duration> ] [ min-update-interval <duration> ] [ policy ( cname |
↳disabled | drop | given | no-op | nxdomain | passthru | tcp-only <quoted_
↳string> ) ] [ recursive-only <boolean> ] [ nsip-enable <boolean> ] [ nsdname-enable
↳<boolean> ]; ... } [ add-soa <boolean> ] [ break-dnssec <boolean> ] [ max-policy-
↳ttl <duration> ] [ min-update-interval <duration> ] [ min-ns-dots <integer> ] [
↳nsip-wait-recurse <boolean> ] [ nsdname-wait-recurse <boolean> ] [ qname-wait-
↳recurse <boolean> ] [ recursive-only <boolean> ] [ nsip-enable <boolean> ] [
↳nsdname-enable <boolean> ] [ dnsrps-enable <boolean> ] [ dnsrps-options {
↳<unspecified-text> } ];
reuseport <boolean>;
root-delegation-only [ exclude { <string>; ... } ]; // deprecated
root-key-sentinel <boolean>;
rrset-order { [ class <string> ] [ type <string> ] [ name <quoted_string> ]
↳<string> <string>; ... };
secroots-file <quoted_string>;
send-cookie <boolean>;
serial-query-rate <integer>;
serial-update-method ( date | increment | unixtime );
server-id ( <quoted_string> | none | hostname );
servfail-ttl <duration>;
session-keyalg <string>;
session-keyfile ( <quoted_string> | none );
session-keyname <string>;
sig-signing-nodes <integer>;
sig-signing-signatures <integer>;
sig-signing-type <integer>;
sig-validity-interval <integer> [ <integer> ];
sortlist { <address_match_element>; ... };
stacksize ( default | unlimited | <sizeval> ); // deprecated
stale-answer-client-timeout ( disabled | off | <integer> );
stale-answer-enable <boolean>;
stale-answer-ttl <duration>;
stale-cache-enable <boolean>;
stale-refresh-time <duration>;
startup-notify-rate <integer>;
statistics-file <quoted_string>;
suppress-initial-notify <boolean>; // obsolete
synth-from-dnssec <boolean>;
tcp-advertised-timeout <integer>;
tcp-clients <integer>;
tcp-idle-timeout <integer>;
tcp-initial-timeout <integer>;
tcp-keepalive-timeout <integer>;
tcp-listen-queue <integer>;

```

(continues on next page)

(continued from previous page)

```

tcp-receive-buffer <integer>;
tcp-send-buffer <integer>;
tkey-dhkey <quoted_string> <integer>; // deprecated
tkey-domain <quoted_string>; // deprecated
tkey-gssapi-credential <quoted_string>; // deprecated
tkey-gssapi-keytab <quoted_string>;
tls-port <integer>;
transfer-format ( many-answers | one-answer );
transfer-message-size <integer>;
transfer-source ( <ipv4_address> | * ) ;
transfer-source-v6 ( <ipv6_address> | * ) ;
transfers-in <integer>;
transfers-out <integer>;
transfers-per-ns <integer>;
trust-anchor-telemetry <boolean>;
try-tcp-refresh <boolean>;
udp-receive-buffer <integer>;
udp-send-buffer <integer>;
update-check-ksk <boolean>;
update-quota <integer>;
use-alt-transfer-source <boolean>; // deprecated
use-v4-udp-ports { <portrange>; ... }; // deprecated
use-v6-udp-ports { <portrange>; ... }; // deprecated
v6-bias <integer>;
validate-except { <string>; ... };
version ( <quoted_string> | none );
zero-no-soa-ttl <boolean>;
zero-no-soa-ttl-cache <boolean>;
zone-statistics ( full | terse | none | <boolean> );
};

parental-agents <string> [ port <integer> ] { ( <remote-servers> | <ipv4_address> [
↳port <integer> ] | <ipv6_address> [ port <integer> ] ) [ key <string> ] [ tls
↳<string> ]; ... }; // may occur multiple times

plugin ( query ) <string> [ { <unspecified-text> } ]; // may occur multiple times

primaries <string> [ port <integer> ] { ( <remote-servers> | <ipv4_address> [ port
↳<integer> ] | <ipv6_address> [ port <integer> ] ) [ key <string> ] [ tls <string> ];
↳ ... }; // may occur multiple times

server <netprefix> {
    bogus <boolean>;
    edns <boolean>;
    edns-udp-size <integer>;
    edns-version <integer>;
    keys <server_key>;
    max-udp-size <integer>;
    notify-source ( <ipv4_address> | * ) ;
    notify-source-v6 ( <ipv6_address> | * ) ;
    padding <integer>;
    provide-ixfr <boolean>;

```

(continues on next page)

(continued from previous page)

```

query-source [ address ] ( <ipv4_address> | * );
query-source-v6 [ address ] ( <ipv6_address> | * );
request-expire <boolean>;
request-ixfr <boolean>;
request-nsid <boolean>;
send-cookie <boolean>;
tcp-keepalive <boolean>;
tcp-only <boolean>;
transfer-format ( many-answers | one-answer );
transfer-source ( <ipv4_address> | * );
transfer-source-v6 ( <ipv6_address> | * );
transfers <integer>;
}; // may occur multiple times

statistics-channels {
    inet ( <ipv4_address> | <ipv6_address> | * ) [ port ( <integer> | * ) ] [
↳allow { <address_match_element>; ... } ]; // may occur multiple times
}; // may occur multiple times

tls <string> {
    ca-file <quoted_string>;
    cert-file <quoted_string>;
    ciphers <string>;
    dhparam-file <quoted_string>;
    key-file <quoted_string>;
    prefer-server-ciphers <boolean>;
    protocols { <string>; ... };
    remote-hostname <quoted_string>;
    session-tickets <boolean>;
}; // may occur multiple times

trust-anchors { <string> ( static-key | initial-key | static-ds | initial-ds )
↳<integer> <integer> <integer> <quoted_string>; ... }; // may occur multiple times

trusted-keys { <string> <integer> <integer> <integer> <quoted_string>; ... }; // may
↳occur multiple times, deprecated

view <string> [ <class> ] {
    allow-new-zones <boolean>;
    allow-notify { <address_match_element>; ... };
    allow-query { <address_match_element>; ... };
    allow-query-cache { <address_match_element>; ... };
    allow-query-cache-on { <address_match_element>; ... };
    allow-query-on { <address_match_element>; ... };
    allow-recursion { <address_match_element>; ... };
    allow-recursion-on { <address_match_element>; ... };
    allow-transfer [ port <integer> ] [ transport <string> ] { <address_match_
↳element>; ... };
    allow-update { <address_match_element>; ... };
    allow-update-forwarding { <address_match_element>; ... };
    also-notify [ port <integer> ] { ( <remote-servers> | <ipv4_address> [ port
↳<integer> ] | <ipv6_address> [ port <integer> ] ) [ key <string> ] [ tls <string> ];

```

(continues on next page)

(continued from previous page)

```

↳ ... };
    alt-transfer-source ( <ipv4_address> | * ) ; // deprecated
    alt-transfer-source-v6 ( <ipv6_address> | * ) ; // deprecated
    attach-cache <string>;
    auth-nxdomain <boolean>;
    auto-dnssec ( allow | maintain | off ); // deprecated
    catalog-zones { zone <string> [ default-primaries [ port <integer> ] { (
↳<remote-servers> | <ipv4_address> [ port <integer> ] | <ipv6_address> [ port
↳<integer> ] ) [ key <string> ] [ tls <string> ]; ... } ] [ zone-directory <quoted_
↳string> ] [ in-memory <boolean> ] [ min-update-interval <duration> ]; ... };
    check-dup-records ( fail | warn | ignore );
    check-integrity <boolean>;
    check-mx ( fail | warn | ignore );
    check-mx-cname ( fail | warn | ignore );
    check-names ( primary | master | secondary | slave | response ) ( fail | warn
↳| ignore ); // may occur multiple times
    check-sibling <boolean>;
    check-spf ( warn | ignore );
    check-srv-cname ( fail | warn | ignore );
    check-wildcard <boolean>;
    clients-per-query <integer>;
    deny-answer-addresses { <address_match_element>; ... } [ except-from {
↳<string>; ... } ];
    deny-answer-aliases { <string>; ... } [ except-from { <string>; ... } ];
    dialup ( notify | notify-passive | passive | refresh | <boolean> ); //
↳deprecated
    disable-algorithms <string> { <string>; ... }; // may occur multiple times
    disable-ds-digests <string> { <string>; ... }; // may occur multiple times
    disable-empty-zone <string>; // may occur multiple times
    dlz <string> {
        database <string>;
        search <boolean>;
    }; // may occur multiple times
    dns64 <netprefix> {
        break-dnssec <boolean>;
        clients { <address_match_element>; ... };
        exclude { <address_match_element>; ... };
        mapped { <address_match_element>; ... };
        recursive-only <boolean>;
        suffix <ipv6_address>;
    }; // may occur multiple times
    dns64-contact <string>;
    dns64-server <string>;
    dnskey-sig-validity <integer>;
    dnsrps-enable <boolean>; // not configured
    dnsrps-options { <unspecified-text> }; // not configured
    dnssec-accept-expired <boolean>;
    dnssec-dnskey-kskonly <boolean>;
    dnssec-loadkeys-interval <integer>;
    dnssec-must-be-secure <string> <boolean>; // may occur multiple times,
↳deprecated
    dnssec-policy <string>;

```

(continues on next page)

(continued from previous page)

```

dnssec-secure-to-insecure <boolean>;
dnssec-update-mode ( maintain | no-resign );
dnssec-validation ( yes | no | auto );
dnstap { ( all | auth | client | forwarder | resolver | update ) [ ( query | ↵
↵response ) ]; ... }; // not configured
dual-stack-servers [ port <integer> ] { ( <quoted_string> [ port <integer> ] ↵
↵| <ipv4_address> [ port <integer> ] | <ipv6_address> [ port <integer> ] ); ... };
dyndb <string> <quoted_string> { <unspecified-text> }; // may occur multiple ↵
↵times
edns-udp-size <integer>;
empty-contact <string>;
empty-server <string>;
empty-zones-enable <boolean>;
fetch-quota-params <integer> <fixedpoint> <fixedpoint> <fixedpoint>;
fetches-per-server <integer> [ ( drop | fail ) ];
fetches-per-zone <integer> [ ( drop | fail ) ];
forward ( first | only );
forwarders [ port <integer> ] { ( <ipv4_address> | <ipv6_address> ) [ port ↵
↵<integer> ]; ... };
glue-cache <boolean>; // deprecated
ipv4only-contact <string>;
ipv4only-enable <boolean>;
ipv4only-server <string>;
ixfr-from-differences ( primary | master | secondary | slave | <boolean> );
key <string> {
    algorithm <string>;
    secret <string>;
}; // may occur multiple times
key-directory <quoted_string>;
lame-ttl <duration>;
lmbd-mapsize <sizeval>;
managed-keys { <string> ( static-key | initial-key | static-ds | initial-ds ) ↵
↵<integer> <integer> <integer> <quoted_string>; ... }; // may occur multiple times, ↵
↵deprecated
masterfile-format ( raw | text );
masterfile-style ( full | relative );
match-clients { <address_match_element>; ... };
match-destinations { <address_match_element>; ... };
match-recursive-only <boolean>;
max-cache-size ( default | unlimited | <sizeval> | <percentage> );
max-cache-ttl <duration>;
max-clients-per-query <integer>;
max-ixfr-ratio ( unlimited | <percentage> );
max-journal-size ( default | unlimited | <sizeval> );
max-ncache-ttl <duration>;
max-query-count <integer>;
max-query-restarts <integer>;
max-records <integer>;
max-records-per-type <integer>;
max-recursion-depth <integer>;
max-recursion-queries <integer>;
max-refresh-time <integer>;

```

(continues on next page)

(continued from previous page)

```

max-retry-time <integer>;
max-stale-ttl <duration>;
max-transfer-idle-in <integer>;
max-transfer-idle-out <integer>;
max-transfer-time-in <integer>;
max-transfer-time-out <integer>;
max-types-per-name <integer>;
max-udp-size <integer>;
max-zone-ttl ( unlimited | <duration> );
message-compression <boolean>;
min-cache-ttl <duration>;
min-ncache-ttl <duration>;
min-refresh-time <integer>;
min-retry-time <integer>;
minimal-any <boolean>;
minimal-responses ( no-auth | no-auth-recursive | <boolean> );
multi-master <boolean>;
new-zones-directory <quoted_string>;
no-case-compress { <address_match_element>; ... };
nocookie-udp-size <integer>;
notify ( explicit | master-only | primary-only | <boolean> );
notify-delay <integer>;
notify-source ( <ipv4_address> | * ) ;
notify-source-v6 ( <ipv6_address> | * ) ;
notify-to-soa <boolean>;
nsec3-test-zone <boolean>; // test only
nta-lifetime <duration>;
nta-recheck <duration>;
nxdomain-redirect <string>;
parental-source ( <ipv4_address> | * ) ;
parental-source-v6 ( <ipv6_address> | * ) ;
plugin ( query ) <string> [ { <unspecified-text> } ]; // may occur multiple_
↳times
preferred-glue <string>;
prefetch <integer> [ <integer> ];
provide-ixfr <boolean>;
qname-minimization ( strict | relaxed | disabled | off );
query-source [ address ] ( <ipv4_address> | * );
query-source-v6 [ address ] ( <ipv6_address> | * );
rate-limit {
    all-per-second <integer>;
    errors-per-second <integer>;
    exempt-clients { <address_match_element>; ... };
    ipv4-prefix-length <integer>;
    ipv6-prefix-length <integer>;
    log-only <boolean>;
    max-table-size <integer>;
    min-table-size <integer>;
    nodata-per-second <integer>;
    nxdomains-per-second <integer>;
    qps-scale <integer>;
    referrals-per-second <integer>;

```

(continues on next page)

(continued from previous page)

```

        responses-per-second <integer>;
        slip <integer>;
        window <integer>;
    };
    recursion <boolean>;
    request-expire <boolean>;
    request-ixfr <boolean>;
    request-nsid <boolean>;
    require-server-cookie <boolean>;
    resolver-nonbackoff-tries <integer>; // deprecated
    resolver-query-timeout <integer>;
    resolver-retry-interval <integer>; // deprecated
    response-padding { <address_match_element>; ... } block-size <integer>;
    response-policy { zone <string> [ add-soa <boolean> ] [ log <boolean> ] [ max-
↳policy-ttl <duration> ] [ min-update-interval <duration> ] [ policy ( cname |
↳disabled | drop | given | no-op | nxdomain | passthru | tcp-only <quoted_
↳string> ) ] [ recursive-only <boolean> ] [ nsip-enable <boolean> ] [ nsdname-enable
↳<boolean> ]; ... } [ add-soa <boolean> ] [ break-dnssec <boolean> ] [ max-policy-
↳ttl <duration> ] [ min-update-interval <duration> ] [ min-ns-dots <integer> ] [
↳nsip-wait-recurse <boolean> ] [ nsdname-wait-recurse <boolean> ] [ qname-wait-
↳recurse <boolean> ] [ recursive-only <boolean> ] [ nsip-enable <boolean> ] [
↳nsdname-enable <boolean> ] [ dnsrps-enable <boolean> ] [ dnsrps-options {
↳<unspecified-text> } ];
        root-delegation-only [ exclude { <string>; ... } ]; // deprecated
        root-key-sentinel <boolean>;
        rrsset-order { [ class <string> ] [ type <string> ] [ name <quoted_string> ]
↳<string> <string>; ... };
        send-cookie <boolean>;
        serial-update-method ( date | increment | unixtime );
        server <netprefix> {
            bogus <boolean>;
            edns <boolean>;
            edns-udp-size <integer>;
            edns-version <integer>;
            keys <server_key>;
            max-udp-size <integer>;
            notify-source ( <ipv4_address> | * ) ;
            notify-source-v6 ( <ipv6_address> | * ) ;
            padding <integer>;
            provide-ixfr <boolean>;
            query-source [ address ] ( <ipv4_address> | * ) ;
            query-source-v6 [ address ] ( <ipv6_address> | * ) ;
            request-expire <boolean>;
            request-ixfr <boolean>;
            request-nsid <boolean>;
            send-cookie <boolean>;
            tcp-keepalive <boolean>;
            tcp-only <boolean>;
            transfer-format ( many-answers | one-answer );
            transfer-source ( <ipv4_address> | * ) ;
            transfer-source-v6 ( <ipv6_address> | * ) ;
            transfers <integer>;

```

(continues on next page)

(continued from previous page)

```

}; // may occur multiple times
servfail-ttl <duration>;
sig-signing-nodes <integer>;
sig-signing-signatures <integer>;
sig-signing-type <integer>;
sig-validity-interval <integer> [ <integer> ];
sortlist { <address_match_element>; ... };
stale-answer-client-timeout ( disabled | off | <integer> );
stale-answer-enable <boolean>;
stale-answer-ttl <duration>;
stale-cache-enable <boolean>;
stale-refresh-time <duration>;
suppress-initial-notify <boolean>; // obsolete
synth-from-dnssec <boolean>;
transfer-format ( many-answers | one-answer );
transfer-source ( <ipv4_address> | * );
transfer-source-v6 ( <ipv6_address> | * );
trust-anchor-telemetry <boolean>;
trust-anchors { <string> ( static-key | initial-key | static-ds | initial-ds_
↳) <integer> <integer> <integer> <quoted_string>; ... }; // may occur multiple times
trusted-keys { <string> <integer> <integer> <integer> <quoted_string>; ... };
↳// may occur multiple times, deprecated
try-tcp-refresh <boolean>;
update-check-ksk <boolean>;
use-alt-transfer-source <boolean>; // deprecated
v6-bias <integer>;
validate-except { <string>; ... };
zero-no-soa-ttl <boolean>;
zero-no-soa-ttl-cache <boolean>;
zone-statistics ( full | terse | none | <boolean> );
}; // may occur multiple times

```

Any of these zone statements can also be set inside the view statement.

```

zone <string> [ <class> ] {
  type primary;
  allow-query { <address_match_element>; ... };
  allow-query-on { <address_match_element>; ... };
  allow-transfer [ port <integer> ] [ transport <string> ] { <address_match_
↳element>; ... };
  allow-update { <address_match_element>; ... };
  also-notify [ port <integer> ] { ( <remote-servers> | <ipv4_address> [ port
↳<integer> ] | <ipv6_address> [ port <integer> ] ) [ key <string> ] [ tls <string> ];
↳ ... };
  alt-transfer-source ( <ipv4_address> | * ); // deprecated
  alt-transfer-source-v6 ( <ipv6_address> | * ); // deprecated
  auto-dnssec ( allow | maintain | off ); // deprecated
  check-dup-records ( fail | warn | ignore );
  check-integrity <boolean>;
  check-mx ( fail | warn | ignore );
  check-mx-cname ( fail | warn | ignore );

```

(continues on next page)

(continued from previous page)

```

check-names ( fail | warn | ignore );
check-sibling <boolean>;
check-spf ( warn | ignore );
check-srv-cname ( fail | warn | ignore );
check-wildcard <boolean>;
database <string>;
dialup ( notify | notify-passive | passive | refresh | <boolean> ); //␣
↳deprecated
dlz <string>;
dnskey-sig-validity <integer>;
dnssec-dnskey-kskonly <boolean>;
dnssec-loadkeys-interval <integer>;
dnssec-policy <string>;
dnssec-secure-to-insecure <boolean>;
dnssec-update-mode ( maintain | no-resign );
file <quoted_string>;
forward ( first | only );
forwarders [ port <integer> ] { ( <ipv4_address> | <ipv6_address> ) [ port
↳<integer> ]; ... };
inline-signing <boolean>;
ixfr-from-differences <boolean>;
journal <quoted_string>;
key-directory <quoted_string>;
masterfile-format ( raw | text );
masterfile-style ( full | relative );
max-ixfr-ratio ( unlimited | <percentage> );
max-journal-size ( default | unlimited | <sizeval> );
max-records <integer>;
max-records-per-type <integer>;
max-transfer-idle-out <integer>;
max-transfer-time-out <integer>;
max-types-per-name <integer>;
max-zone-ttl ( unlimited | <duration> );
notify ( explicit | master-only | primary-only | <boolean> );
notify-delay <integer>;
notify-source ( <ipv4_address> | * );
notify-source-v6 ( <ipv6_address> | * );
notify-to-soa <boolean>;
nsec3-test-zone <boolean>; // test only
parental-agents [ port <integer> ] { ( <remote-servers> | <ipv4_address> [␣
↳port <integer> ] | <ipv6_address> [ port <integer> ] ) [ key <string> ] [ tls
↳<string> ]; ... };
parental-source ( <ipv4_address> | * );
parental-source-v6 ( <ipv6_address> | * );
serial-update-method ( date | increment | unixtime );
sig-signing-nodes <integer>;
sig-signing-signatures <integer>;
sig-signing-type <integer>;
sig-validity-interval <integer> [ <integer> ];
update-check-ksk <boolean>;
update-policy ( local | { ( deny | grant ) <string> ( 6to4-self | external |␣
↳krb5-self | krb5-selfsub | krb5-subdomain | krb5-subdomain-self-rhs | ms-self | ms-

```

(continues on next page)

(continued from previous page)

```

↪selfsub | ms-subdomain | ms-subdomain-self-rhs | name | self | selfsub | selfwild | ↪
↪subdomain | tcp-self | wildcard | zonesub ) [ <string> ] <rrtypelist>; ... } );
    zero-no-soa-ttl <boolean>;
    zone-statistics ( full | terse | none | <boolean> );
};

```

```

zone <string> [ <class> ] {
    type secondary;
    allow-notify { <address_match_element>; ... };
    allow-query { <address_match_element>; ... };
    allow-query-on { <address_match_element>; ... };
    allow-transfer [ port <integer> ] [ transport <string> ] { <address_match_
↪element>; ... };
    allow-update-forwarding { <address_match_element>; ... };
    also-notify [ port <integer> ] { ( <remote-servers> | <ipv4_address> [ port
↪<integer> ] | <ipv6_address> [ port <integer> ] ) [ key <string> ] [ tls <string> ];
↪ ... };
    alt-transfer-source ( <ipv4_address> | * ) ; // deprecated
    alt-transfer-source-v6 ( <ipv6_address> | * ) ; // deprecated
    auto-dnssec ( allow | maintain | off ) ; // deprecated
    check-names ( fail | warn | ignore ) ;
    database <string>;
    dialup ( notify | notify-passive | passive | refresh | <boolean> ) ; //↪
↪deprecated
    dlz <string>;
    dnskey-sig-validity <integer>;
    dnssec-dnskey-kskonly <boolean>;
    dnssec-loadkeys-interval <integer>;
    dnssec-policy <string>;
    dnssec-update-mode ( maintain | no-resign );
    file <quoted_string>;
    forward ( first | only );
    forwarders [ port <integer> ] { ( <ipv4_address> | <ipv6_address> ) [ port
↪<integer> ]; ... };
    inline-signing <boolean>;
    ixfr-from-differences <boolean>;
    journal <quoted_string>;
    key-directory <quoted_string>;
    masterfile-format ( raw | text );
    masterfile-style ( full | relative );
    max-ixfr-ratio ( unlimited | <percentage> );
    max-journal-size ( default | unlimited | <sizeval> );
    max-records <integer>;
    max-records-per-type <integer>;
    max-refresh-time <integer>;
    max-retry-time <integer>;
    max-transfer-idle-in <integer>;
    max-transfer-idle-out <integer>;
    max-transfer-time-in <integer>;
    max-transfer-time-out <integer>;
    max-types-per-name <integer>;
    min-refresh-time <integer>;

```

(continues on next page)

(continued from previous page)

```

min-retry-time <integer>;
multi-master <boolean>;
notify ( explicit | master-only | primary-only | <boolean> );
notify-delay <integer>;
notify-source ( <ipv4_address> | * ) ;
notify-source-v6 ( <ipv6_address> | * ) ;
notify-to-soa <boolean>;
nsec3-test-zone <boolean>; // test only
parental-agents [ port <integer> ] { ( <remote-servers> | <ipv4_address> [
↳port <integer> ] | <ipv6_address> [ port <integer> ] ) [ key <string> ] [ tls
↳<string> ]; ... };
parental-source ( <ipv4_address> | * ) ;
parental-source-v6 ( <ipv6_address> | * ) ;
primaries [ port <integer> ] { ( <remote-servers> | <ipv4_address> [ port
↳<integer> ] | <ipv6_address> [ port <integer> ] ) [ key <string> ] [ tls <string> ];
↳ ... };
request-expire <boolean>;
request-ixfr <boolean>;
sig-signing-nodes <integer>;
sig-signing-signatures <integer>;
sig-signing-type <integer>;
sig-validity-interval <integer> [ <integer> ];
transfer-source ( <ipv4_address> | * ) ;
transfer-source-v6 ( <ipv6_address> | * ) ;
try-tcp-refresh <boolean>;
update-check-ksk <boolean>;
use-alt-transfer-source <boolean>; // deprecated
zero-no-soa-ttl <boolean>;
zone-statistics ( full | terse | none | <boolean> );
};

```

```

zone <string> [ <class> ] {
    type mirror;
    allow-notify { <address_match_element>; ... };
    allow-query { <address_match_element>; ... };
    allow-query-on { <address_match_element>; ... };
    allow-transfer [ port <integer> ] [ transport <string> ] { <address_match_
↳element>; ... };
    allow-update-forwarding { <address_match_element>; ... };
    also-notify [ port <integer> ] { ( <remote-servers> | <ipv4_address> [ port
↳<integer> ] | <ipv6_address> [ port <integer> ] ) [ key <string> ] [ tls <string> ];
↳ ... };
    alt-transfer-source ( <ipv4_address> | * ) ; // deprecated
    alt-transfer-source-v6 ( <ipv6_address> | * ) ; // deprecated
    check-names ( fail | warn | ignore );
    database <string>;
    file <quoted_string>;
    ixfr-from-differences <boolean>;
    journal <quoted_string>;
    masterfile-format ( raw | text );
    masterfile-style ( full | relative );
    max-ixfr-ratio ( unlimited | <percentage> );
};

```

(continues on next page)

(continued from previous page)

```

max-journal-size ( default | unlimited | <sizeval> );
max-records <integer>;
max-records-per-type <integer>;
max-refresh-time <integer>;
max-retry-time <integer>;
max-transfer-idle-in <integer>;
max-transfer-idle-out <integer>;
max-transfer-time-in <integer>;
max-transfer-time-out <integer>;
max-types-per-name <integer>;
min-refresh-time <integer>;
min-retry-time <integer>;
multi-master <boolean>;
notify ( explicit | master-only | primary-only | <boolean> );
notify-delay <integer>;
notify-source ( <ipv4_address> | * ) ;
notify-source-v6 ( <ipv6_address> | * ) ;
primaries [ port <integer> ] { ( <remote-servers> | <ipv4_address> [ port
↪<integer> ] | <ipv6_address> [ port <integer> ] ) [ key <string> ] [ tls <string> ];
↪ ... };
request-expire <boolean>;
request-ixfr <boolean>;
transfer-source ( <ipv4_address> | * ) ;
transfer-source-v6 ( <ipv6_address> | * ) ;
try-tcp-refresh <boolean>;
use-alt-transfer-source <boolean>; // deprecated
zero-no-soa-ttl <boolean>;
zone-statistics ( full | terse | none | <boolean> );
};

```

```

zone <string> [ <class> ] {
    type forward;
    delegation-only <boolean>; // deprecated
    forward ( first | only );
    forwarders [ port <integer> ] { ( <ipv4_address> | <ipv6_address> ) [ port
↪<integer> ]; ... };
};

```

```

zone <string> [ <class> ] {
    type hint;
    check-names ( fail | warn | ignore );
    delegation-only <boolean>; // deprecated
    file <quoted_string>;
};

```

```

zone <string> [ <class> ] {
    type redirect;
    allow-query { <address_match_element>; ... };
    allow-query-on { <address_match_element>; ... };
    dlz <string>;
    file <quoted_string>;
};

```

(continues on next page)

(continued from previous page)

```

masterfile-format ( raw | text );
masterfile-style ( full | relative );
max-records <integer>;
max-records-per-type <integer>;
max-types-per-name <integer>;
max-zone-ttl ( unlimited | <duration> );
primaries [ port <integer> ] { ( <remote-servers> | <ipv4_address> [ port
↪<integer> ] | <ipv6_address> [ port <integer> ] ) [ key <string> ] [ tls <string> ];
↪ ... };
zone-statistics ( full | terse | none | <boolean> );
};

```

```

zone <string> [ <class> ] {
type static-stub;
allow-query { <address_match_element>; ... };
allow-query-on { <address_match_element>; ... };
forward ( first | only );
forwarders [ port <integer> ] { ( <ipv4_address> | <ipv6_address> ) [ port
↪<integer> ]; ... };
max-records <integer>;
max-records-per-type <integer>;
max-types-per-name <integer>;
server-addresses { ( <ipv4_address> | <ipv6_address> ); ... };
server-names { <string>; ... };
zone-statistics ( full | terse | none | <boolean> );
};

```

```

zone <string> [ <class> ] {
type stub;
allow-query { <address_match_element>; ... };
allow-query-on { <address_match_element>; ... };
check-names ( fail | warn | ignore );
database <string>;
delegation-only <boolean>; // deprecated
dialup ( notify | notify-passive | passive | refresh | <boolean> ); //↵
↪deprecated
file <quoted_string>;
forward ( first | only );
forwarders [ port <integer> ] { ( <ipv4_address> | <ipv6_address> ) [ port
↪<integer> ]; ... };
masterfile-format ( raw | text );
masterfile-style ( full | relative );
max-records <integer>;
max-records-per-type <integer>;
max-refresh-time <integer>;
max-retry-time <integer>;
max-transfer-idle-in <integer>;
max-transfer-time-in <integer>;
max-types-per-name <integer>;
min-refresh-time <integer>;
min-retry-time <integer>;

```

(continues on next page)

(continued from previous page)

```

multi-master <boolean>;
primaries [ port <integer> ] { ( <remote-servers> | <ipv4_address> [ port
↪<integer> ] | <ipv6_address> [ port <integer> ] ) [ key <string> ] [ tls <string> ];
↪ ... };
transfer-source ( <ipv4_address> | * ) ;
transfer-source-v6 ( <ipv6_address> | * ) ;
use-alt-transfer-source <boolean>; // deprecated
zone-statistics ( full | terse | none | <boolean> );
};

```

```

zone <string> [ <class> ] {
    type delegation-only;
};

```

```

zone <string> [ <class> ] {
    in-view <string>;
};

```

### 12.24.3 Files

/usr/local/etc/named.conf

### 12.24.4 See Also

*named(8)*, *named-checkconf(8)*, *rndc(8)*, *rndc-confgen(8)*, *tsig-keygen(8)*, BIND 9 Administrator Reference Manual.

## 12.25 named - Internet domain name server

### 12.25.1 Synopsis

```

named [ [-4] | [-6] ] [-c config-file] [-C] [-d debug-level] [-D string] [-E engine-name] [-f] [-g] [-L logfile] [-M option]
[-m flag] [-n #cpus] [-p port] [-s] [-t directory] [-U #listeners] [-u user] [-v] [-V] [-X lock-file]

```

### 12.25.2 Description

**named** is a Domain Name System (DNS) server, part of the BIND 9 distribution from ISC. For more information on the DNS, see [RFC 1033](#), [RFC 1034](#), and [RFC 1035](#).

When invoked without arguments, **named** reads the default configuration file `/usr/local/etc/named.conf`, reads any initial data, and listens for queries.

### 12.25.3 Options

-4

This option tells **named** to use only IPv4, even if the host machine is capable of IPv6. `-4` and `-6` are mutually exclusive.

-6

This option tells **named** to use only IPv6, even if the host machine is capable of IPv4. `-4` and `-6` are mutually exclusive.

**-c** *config-file*

This option tells **named** to use *config-file* as its configuration file instead of the default, `/usr/local/etc/named.conf`. To ensure that the configuration file can be reloaded after the server has changed its working directory due to a possible `directory` option in the configuration file, *config-file* should be an absolute pathname.

**-C**

This option prints out the default built-in configuration and exits.

NOTE: This is for debugging purposes only and is not an accurate representation of the actual configuration used by *named* at runtime.

**-d** *debug-level*

This option sets the daemon's debug level to *debug-level*. Debugging traces from **named** become more verbose as the debug level increases.

**-D** *string*

This option specifies a string that is used to identify a instance of **named** in a process listing. The contents of *string* are not examined.

**-E** *engine-name*

When applicable, this option specifies the hardware to use for cryptographic operations, such as a secure key store used for signing.

When BIND 9 is built with OpenSSL, this needs to be set to the OpenSSL engine identifier that drives the cryptographic accelerator or hardware service module (usually `pkcs11`).

**-f**

This option runs the server in the foreground (i.e., do not daemonize).

**-g**

This option runs the server in the foreground and forces all logging to `stderr`.

**-L** *logfile*

This option sets the log to the file *logfile* by default, instead of the system log.

**-M** *option*

This option sets the default (comma-separated) memory context options. The possible flags are:

- `fill`: fill blocks of memory with tag values when they are allocated or freed, to assist debugging of memory problems; this is the implicit default if **named** has been compiled with `--enable-developer`.
- `nofill`: disable the behavior enabled by `fill`; this is the implicit default unless **named** has been compiled with `--enable-developer`.

**-m** *flag*

This option turns on memory usage debugging flags. Possible flags are `usage`, `trace` and `record`. These correspond to the `ISC_MEM_DEBUGXXXX` flags described in `<isc/mem.h>`.

**-n** *#cpus*

This option creates *#cpus* worker threads to take advantage of multiple CPUs. If not specified, **named** tries to determine the number of CPUs present and creates one thread per CPU. If it is unable to determine the number of CPUs, a single worker thread is created.

**-p** *value*

This option specifies the port(s) on which the server will listen for queries. If *value* is of the form `<portnum>` or `dns=<portnum>`, the server will listen for DNS queries on *portnum*; if not specified, the default is port 53. If *value* is of the form `tls=<portnum>`, the server will listen for TLS queries on *portnum*; the default is 853. If *value* is of the form `https=<portnum>`, the server will listen for HTTPS queries on *portnum*; the default is

443. If `value` is of the form `http=<portnum>`, the server will listen for HTTP queries on `portnum`; the default is 80.

**-s**

This option writes memory usage statistics to `stdout` on exit.

**Note**

This option is mainly of interest to BIND 9 developers and may be removed or changed in a future release.

**-S** `#max-socks`

This option is deprecated and no longer has any function.

**Warning**

This option should be unnecessary for the vast majority of users. The use of this option could even be harmful, because the specified value may exceed the limitation of the underlying system API. It is therefore set only when the default configuration causes exhaustion of file descriptors and the operational environment is known to support the specified number of sockets. Note also that the actual maximum number is normally slightly fewer than the specified value, because **named** reserves some file descriptors for its internal use.

**-t** `directory`

This option tells **named** to chroot to `directory` after processing the command-line arguments, but before reading the configuration file.

**Warning**

This option should be used in conjunction with the `-u` option, as chrooting a process running as root doesn't enhance security on most systems; the way `chroot` is defined allows a process with root privileges to escape a chroot jail.

**-U** `#dispatches`

This option specifies the number of per-interface UDP `#dispatches` that **named** should use to handle the outgoing (recursive) UDP connection, to reduce contention between the resolver threads.

If not specified, **named** calculates a default value based on the number of detected CPUs: 1 for a single CPU, and the number of detected CPUs minus one for machines with more than 1 CPU.

This cannot be increased to a value higher than the number of CPUs (see `-n` on how to override the value).

**Warning**

This option should be unnecessary for the vast majority of users, and will be removed in the next version of BIND 9.

**-u** `user`

This option sets the setuid to `user` after completing privileged operations, such as creating sockets that listen on privileged ports.

**Note**

On Linux, **named** uses the kernel's capability mechanism to drop all root privileges except the ability to bind to a privileged port and set process resource limits. Unfortunately, this means that the `-u` option only works when **named** is run on kernel 2.2.18 or later, or kernel 2.3.99-pre3 or later, since previous kernels did not allow privileges to be retained after `setuid`.

**-v**

This option reports the version number and exits.

**-V**

This option reports the version number, build options, supported cryptographic algorithms, and exits.

**-x lock-file**

This option acquires a lock on the specified file at runtime; this helps to prevent duplicate **named** instances from running simultaneously. Use of this option overrides the `lock-file` option in `named.conf`. If set to `none`, the lock file check is disabled.

### 12.25.4 Signals

In routine operation, signals should not be used to control the nameserver; `rndc` should be used instead.

#### SIGHUP

This signal forces a reload of the server.

#### SIGINT, SIGTERM

These signals shut down the server.

The result of sending any other signals to the server is undefined.

### 12.25.5 Configuration

The **named** configuration file is too complex to describe in detail here. A complete description is provided in the BIND 9 Administrator Reference Manual.

**named** inherits the `umask` (file creation mode mask) from the parent process. If files created by **named**, such as journal files, need to have custom permissions, the `umask` should be set explicitly in the script used to start the **named** process.

### 12.25.6 Files

`/usr/local/etc/named.conf`

The default configuration file.

`/usr/local/var/run/named.pid`

The default process-id file.

### 12.25.7 See Also

[RFC 1033](#), [RFC 1034](#), [RFC 1035](#), [named-checkconf\(8\)](#), [named-checkzone\(8\)](#), [rndc\(8\)](#), [named.conf\(5\)](#), BIND 9 Administrator Reference Manual.

## 12.26 nsec3hash - generate NSEC3 hash

### 12.26.1 Synopsis

`nsec3hash` {salt} {algorithm} {iterations} {domain}

**nsec3hash -r** {algorithm} {flags} {iterations} {salt} {domain}

## 12.26.2 Description

**nsec3hash** generates an NSEC3 hash based on a set of NSEC3 parameters. This can be used to check the validity of NSEC3 records in a signed zone.

If this command is invoked as `nsec3hash -r`, it takes arguments in order, matching the first four fields of an NSEC3 record followed by the domain name: `algorithm`, `flags`, `iterations`, `salt`, `domain`. This makes it convenient to copy and paste a portion of an NSEC3 or NSEC3PARAM record into a command line to confirm the correctness of an NSEC3 hash.

## 12.26.3 Arguments

### **salt**

This is the salt provided to the hash algorithm.

### **algorithm**

This is a number indicating the hash algorithm. Currently the only supported hash algorithm for NSEC3 is SHA-1, which is indicated by the number 1; consequently "1" is the only useful value for this argument.

### **flags**

This is provided for compatibility with NSEC3 record presentation format, but is ignored since the flags do not affect the hash.

### **iterations**

This is the number of additional times the hash should be performed.

### **domain**

This is the domain name to be hashed.

## 12.26.4 See Also

BIND 9 Administrator Reference Manual, [RFC 5155](#).

## 12.27 nslookup - query Internet name servers interactively

### 12.27.1 Synopsis

**nslookup** [-option] [name | -] [server]

### 12.27.2 Description

**nslookup** is a program to query Internet domain name servers. **nslookup** has two modes: interactive and non-interactive. Interactive mode allows the user to query name servers for information about various hosts and domains or to print a list of hosts in a domain. Non-interactive mode prints just the name and requested information for a host or domain.

### 12.27.3 Arguments

Interactive mode is entered in the following cases:

- a. when no arguments are given (the default name server is used);
- b. when the first argument is a hyphen (-) and the second argument is the host name or Internet address of a name server.

Non-interactive mode is used when the name or Internet address of the host to be looked up is given as the first argument. The optional second argument specifies the host name or address of a name server.

Options can also be specified on the command line if they precede the arguments and are prefixed with a hyphen. For example, to change the default query type to host information, with an initial timeout of 10 seconds, type:

```
nslookup -query=hinfo -timeout=10
```

The `-version` option causes `nslookup` to print the version number and immediately exit.

## 12.27.4 Interactive Commands

### **host** [**server**]

This command looks up information for *host* using the current default server or using *server*, if specified. If *host* is an Internet address and the query type is A or PTR, the name of the host is returned. If *host* is a name and does not have a trailing period (`.`), the search list is used to qualify the name.

To look up a host not in the current domain, append a period to the name.

### **server domain** | **lserver domain**

These commands change the default server to *domain*; `lserver` uses the initial server to look up information about *domain*, while `server` uses the current default server. If an authoritative answer cannot be found, the names of servers that might have the answer are returned.

### **root**

This command is not implemented.

### **finger**

This command is not implemented.

### **ls**

This command is not implemented.

### **view**

This command is not implemented.

### **help**

This command is not implemented.

### **?**

This command is not implemented.

### **exit**

This command exits the program.

### **set keyword**[=**value**]

This command is used to change state information that affects the lookups. Valid keywords are:

#### **all**

This keyword prints the current values of the frequently used options to `set`. Information about the current default server and host is also printed.

#### **class=value**

This keyword changes the query class to one of:

##### **IN**

the Internet class

##### **CH**

the Chaos class

**HS**  
the Hesiod class

**ANY**  
wildcard

The class specifies the protocol group of the information. The default is `IN`; the abbreviation for this keyword is `cl`.

**nodebug**  
This keyword turns on or off the display of the full response packet, and any intermediate response packets, when searching. The default for this keyword is `nodebug`; the abbreviation for this keyword is `[no]deb`.

**nod2**  
This keyword turns debugging mode on or off. This displays more about what nslookup is doing. The default is `nod2`.

**domain=name**  
This keyword sets the search list to `name`.

**nosearch**  
If the lookup request contains at least one period, but does not end with a trailing period, this keyword appends the domain names in the domain search list to the request until an answer is received. The default is `search`.

**port=value**  
This keyword changes the default TCP/UDP name server port to `value` from its default, port 53. The abbreviation for this keyword is `po`.

**querytype=value | type=value**  
This keyword changes the type of the information query to `value`. The defaults are `A` and then `AAAA`; the abbreviations for these keywords are `q` and `ty`.

Please note that it is only possible to specify one query type. Only the default behavior looks up both when an alternative is not specified.

**norecurse**  
This keyword tells the name server to query other servers if it does not have the information. The default is `recurse`; the abbreviation for this keyword is `[no]rec`.

**ndots=number**  
This keyword sets the number of dots (label separators) in a domain that disables searching. Absolute names always stop searching.

**retry=number**  
This keyword sets the number of retries to `number`.

**timeout=number**  
This keyword changes the initial timeout interval to wait for a reply to `number`, in seconds.

**novc**  
This keyword indicates that a virtual circuit should always be used when sending requests to the server. `novc` is the default.

**nofail**  
This keyword tries the next nameserver if a nameserver responds with `SERVFAIL` or a referral (`nofail`), or terminates the query (`fail`) on such a response. The default is `nofail`.

### 12.27.5 Return Values

`nslookup` returns with an exit status of 1 if any query failed, and 0 otherwise.

### 12.27.6 IDN Support

If `nslookup` has been built with IDN (internationalized domain name) support, it can accept and display non-ASCII domain names. `nslookup` appropriately converts character encoding of a domain name before sending a request to a DNS server or displaying a reply from the server. To turn off IDN support, define the `IDN_DISABLE` environment variable. IDN support is disabled if the variable is set when `nslookup` runs, or when the standard output is not a tty.

### 12.27.7 Files

`/etc/resolv.conf`

### 12.27.8 See Also

*dig(1), host(1), named(8).*

## 12.28 nsupdate - dynamic DNS update utility

### 12.28.1 Synopsis

```
nsupdate [-d] [-D] [-i] [-L level] [ [-g] | [-o] | [-I] | [-y [hmac:]keyname:secret] | [-k keyfile] ] [-t timeout] [-u udptimeout]
[-r udpretries] [-v] [-T] [-P] [-V] [ [-4] | [-6] ] [filename]
```

### 12.28.2 Description

`nsupdate` is used to submit Dynamic DNS Update requests, as defined in [RFC 2136](#), to a name server. This allows resource records to be added or removed from a zone without manually editing the zone file. A single update request can contain requests to add or remove more than one resource record.

Zones that are under dynamic control via `nsupdate` or a DHCP server should not be edited by hand. Manual edits could conflict with dynamic updates and cause data to be lost.

The resource records that are dynamically added or removed with `nsupdate` must be in the same zone. Requests are sent to the zone's primary server, which is identified by the MNAME field of the zone's SOA record.

Transaction signatures can be used to authenticate the Dynamic DNS updates. These use the TSIG resource record type described in [RFC 2845](#), the SIG(0) record described in [RFC 2535](#) and [RFC 2931](#), or GSS-TSIG as described in [RFC 3645](#).

TSIG relies on a shared secret that should only be known to `nsupdate` and the name server. For instance, suitable `key` and `server` statements are added to `/usr/local/etc/named.conf` so that the name server can associate the appropriate secret key and algorithm with the IP address of the client application that is using TSIG authentication. `ddns-confgen` can generate suitable configuration fragments. `nsupdate` uses the `-y` or `-k` options to provide the TSIG shared secret; these options are mutually exclusive.

SIG(0) uses public key cryptography. To use a SIG(0) key, the public key must be stored in a KEY record in a zone served by the name server.

GSS-TSIG uses Kerberos credentials. Standard GSS-TSIG mode is switched on with the `-g` flag. A non-standards-compliant variant of GSS-TSIG used by Windows 2000 can be switched on with the `-o` flag.

### 12.28.3 Options

- 4**  
This option sets use of IPv4 only.
- 6**  
This option sets use of IPv6 only.
- C**  
Overrides the default *resolv.conf* file. This is only intended for testing.
- d**  
This option sets debug mode, which provides tracing information about the update requests that are made and the replies received from the name server.
- D**  
This option sets extra debug mode.
- g**  
This option enables standard GSS-TSIG mode.
- i**  
This option forces interactive mode, even when standard input is not a terminal.
- k** *keyfile*  
This option indicates the file containing the TSIG authentication key. Keyfiles may be in two formats: a single file containing a *named.conf*-format *key* statement, which may be generated automatically by *ddns-confgen*; or a pair of files whose names are of the format *K{name}.+157.+{random}.key* and *K{name}.+157.+{random}.private*, which can be generated by *dnssec-keygen*. The *-k* option can also be used to specify a SIG(0) key used to authenticate Dynamic DNS update requests. In this case, the key specified is not an HMAC-MD5 key.
- l**  
This option sets local-host only mode, which sets the server address to localhost (disabling the *server* so that the server address cannot be overridden). Connections to the local server use a TSIG key found in */usr/local/var/run/session.key*, which is automatically generated by *named* if any local primary zone has set *update-policy* to *local*. The location of this key file can be overridden with the *-k* option.
- L** *level*  
This option sets the logging debug level. If zero, logging is disabled.
- o**  
This option enables a non-standards-compliant variant of GSS-TSIG used by Windows 2000.
- p** *port*  
This option sets the port to use for connections to a name server. The default is 53.
- P**  
This option prints the list of private BIND-specific resource record types whose format is understood by *nsupdate*. See also the *-T* option.
- r** *udpretries*  
This option sets the number of UDP retries. The default is 3. If zero, only one update request is made.
- t** *timeout*  
This option sets the maximum time an update request can take before it is aborted. The default is 300 seconds. If zero, the timeout is disabled for TCP mode. For UDP mode, the option *-u* takes precedence over this option, unless the option *-u* is set to zero, in which case the interval is computed from the *-t* timeout interval and the

number of UDP retries. For UDP mode, the timeout can not be disabled, and will be rounded up to 1 second in case if both `-t` and `-u` are set to zero.

**-T**

This option prints the list of IANA standard resource record types whose format is understood by **nsupdate**. **nsupdate** exits after the lists are printed. The `-T` option can be combined with the `-P` option.

Other types can be entered using `TYPEXXXXX` where `XXXXX` is the decimal value of the type with no leading zeros. The rdata, if present, is parsed using the UNKNOWN rdata format, (`<backslash> <hash> <space> <length> <space> <hexstring>`).

**-u** `udptimeout`

This option sets the UDP retry interval. The default is 3 seconds. If zero, the interval is computed from the timeout interval and number of UDP retries.

**-v**

This option specifies that TCP should be used even for small update requests. By default, **nsupdate** uses UDP to send update requests to the name server unless they are too large to fit in a UDP request, in which case TCP is used. TCP may be preferable when a batch of update requests is made.

**-V**

This option prints the version number and exits.

**-y** [`hmac:`] `keyname:secret`

This option sets the literal TSIG authentication key. `keyname` is the name of the key, and `secret` is the base64 encoded shared secret. `hmac` is the name of the key algorithm; valid choices are `hmac-md5`, `hmac-sha1`, `hmac-sha224`, `hmac-sha256`, `hmac-sha384`, or `hmac-sha512`. If `hmac` is not specified, the default is `hmac-md5`, or if MD5 was disabled, `hmac-sha256`.

NOTE: Use of the `-y` option is discouraged because the shared secret is supplied as a command-line argument in clear text. This may be visible in the output from `ps1` or in a history file maintained by the user's shell.

## 12.28.4 Input Format

**nsupdate** reads input from `filename` or standard input. Each command is supplied on exactly one line of input. Some commands are for administrative purposes; others are either update instructions or prerequisite checks on the contents of the zone. These checks set conditions that some name or set of resource records (RRset) either exists or is absent from the zone. These conditions must be met if the entire update request is to succeed. Updates are rejected if the tests for the prerequisite conditions fail.

Every update request consists of zero or more prerequisites and zero or more updates. This allows a suitably authenticated update request to proceed if some specified resource records are either present or missing from the zone. A blank input line (or the `send` command) causes the accumulated commands to be sent as one Dynamic DNS update request to the name server.

The command formats and their meanings are as follows:

**server servername port**

This command sends all dynamic update requests to the name server `servername`. When no server statement is provided, **nsupdate** sends updates to the primary server of the correct zone. The MNAME field of that zone's SOA record identify the primary server for that zone. `port` is the port number on `servername` where the dynamic update requests are sent. If no port number is specified, the default DNS port number of 53 is used.

**Note**

This command has no effect when GSS-TSIG is in use.

**local address port**

This command sends all dynamic update requests using the local `address`. When no local statement is provided, `nsupdate` sends updates using an address and port chosen by the system. `port` can also be used to force requests to come from a specific port. If no port number is specified, the system assigns one.

**zone zonename**

This command specifies that all updates are to be made to the zone `zonename`. If no `zone` statement is provided, `nsupdate` attempts to determine the correct zone to update based on the rest of the input.

**class classname**

This command specifies the default class. If no `class` is specified, the default class is `IN`.

**ttl seconds**

This command specifies the default time-to-live, in seconds, for records to be added. The value `none` clears the default TTL.

**key hmac:keyname secret**

This command specifies that all updates are to be TSIG-signed using the `keyname-secret` pair. If `hmac` is specified, it sets the signing algorithm in use. The default is `hmac-md5`; if MD5 was disabled, the default is `hmac-sha256`. The `key` command overrides any key specified on the command line via `-y` or `-k`.

**gsstsig**

This command uses GSS-TSIG to sign the updates. This is equivalent to specifying `-g` on the command line.

**oldgsstsig**

This command uses the Windows 2000 version of GSS-TSIG to sign the updates. This is equivalent to specifying `-o` on the command line.

**realm [realm\_name]**

When using GSS-TSIG, this command specifies the use of `realm_name` rather than the default realm in `krb5.conf`. If no realm is specified, the saved realm is cleared.

**check-names [boolean]**

This command turns on or off check-names processing on records to be added. Check-names has no effect on prerequisites or records to be deleted. By default check-names processing is on. If check-names processing fails, the record is not added to the UPDATE message.

**prereq nxdomain domain-name**

This command requires that no resource record of any type exist with the name `domain-name`.

**prereq yxdomain domain-name**

This command requires that `domain-name` exist (as at least one resource record, of any type).

**prereq nxrrset domain-name class type**

This command requires that no resource record exist of the specified `type`, `class`, and `domain-name`. If `class` is omitted, `IN` (Internet) is assumed.

**prereq yxrrset domain-name class type**

This command requires that a resource record of the specified `type`, `class` and `domain-name` exist. If `class` is omitted, `IN` (internet) is assumed.

**prereq yxrrset domain-name class type data**

With this command, the `data` from each set of prerequisites of this form sharing a common `type`, `class`, and `domain-name` are combined to form a set of RRs. This set of RRs must exactly match the set of RRs existing in the zone at the given `type`, `class`, and `domain-name`. The `data` are written in the standard text representation of the resource record's RDATA.

**update delete domain-name ttl class type data**

This command deletes any resource records named `domain-name`. If `type` and `data` are provided, only matching resource records are removed. The Internet class is assumed if `class` is not supplied. The `ttl` is ignored, and is only allowed for compatibility.

**update add domain-name ttl class type data**

This command adds a new resource record with the specified `ttl`, `class`, and `data`.

**show**

This command displays the current message, containing all of the prerequisites and updates specified since the last send.

**send**

This command sends the current message. This is equivalent to entering a blank line.

**answer**

This command displays the answer.

**debug**

This command turns on debugging.

**version**

This command prints the version number.

**help**

This command prints a list of commands.

Lines beginning with a semicolon (;) are comments and are ignored.

## 12.28.5 Examples

The examples below show how **nsupdate** can be used to insert and delete resource records from the `example.com` zone. Notice that the input in each example contains a trailing blank line, so that a group of commands is sent as one dynamic update request to the primary name server for `example.com`.

```
# nsupdate
> update delete oldhost.example.com A
> update add newhost.example.com 86400 A 172.16.1.1
> send
```

Any A records for `oldhost.example.com` are deleted, and an A record for `newhost.example.com` with IP address 172.16.1.1 is added. The newly added record has a TTL of 1 day (86400 seconds).

```
# nsupdate
> prereq nxdomain nickname.example.com
> update add nickname.example.com 86400 CNAME somehost.example.com
> send
```

The prerequisite condition tells the name server to verify that there are no resource records of any type for `nickname.example.com`. If there are, the update request fails. If this name does not exist, a CNAME for it is added. This ensures that when the CNAME is added, it cannot conflict with the long-standing rule in **RFC 1034** that a name must not exist as any other record type if it exists as a CNAME. (The rule has been updated for DNSSEC in **RFC 2535** to allow CNAMEs to have RRSIG, DNSKEY, and NSEC records.)

## 12.28.6 Files

`/etc/resolv.conf`

Used to identify the default name server

`/usr/local/var/run/session.key`

Sets the default TSIG key for use in local-only mode

`K{name} .+157 .+{random} .key`

Base-64 encoding of the HMAC-MD5 key created by `dnssec-keygen`.

`K{name} .+157 .+{random} .private`

Base-64 encoding of the HMAC-MD5 key created by `dnssec-keygen`.

## 12.28.7 See Also

[RFC 2136](#), [RFC 3007](#), [RFC 2104](#), [RFC 2845](#), [RFC 1034](#), [RFC 2535](#), [RFC 2931](#), [named\(8\)](#), [dnssec-keygen\(8\)](#), [tsig-keygen\(8\)](#).

## 12.28.8 Bugs

The TSIG key is redundantly stored in two separate files. This is a consequence of `nsupdate` using the DST library for its cryptographic operations, and may change in future releases.

# 12.29 rndc-confgen - rndc key generation tool

## 12.29.1 Synopsis

`rndc-confgen` [-a] [-A algorithm] [-b keysize] [-c keyfile] [-h] [-k keyname] [-p port] [-s address] [-t chrootdir] [-u user]

## 12.29.2 Description

`rndc-confgen` generates configuration files for `rndc`. It can be used as a convenient alternative to writing the `rndc.conf` file and the corresponding `controls` and `key` statements in `named.conf` by hand. Alternatively, it can be run with the `-a` option to set up a `rndc.key` file and avoid the need for a `rndc.conf` file and a `controls` statement altogether.

## 12.29.3 Options

`-a`

This option sets automatic `rndc` configuration, which creates a file `/usr/local/etc/rndc.key` that is read by both `rndc` and `named` on startup. The `rndc.key` file defines a default command channel and authentication key allowing `rndc` to communicate with `named` on the local host with no further configuration.

If a more elaborate configuration than that generated by `rndc-confgen -a` is required, for example if `rndc` is to be used remotely, run `rndc-confgen` without the `-a` option and set up `rndc.conf` and `named.conf` as directed.

`-A algorithm`

This option specifies the algorithm to use for the TSIG key. Available choices are: `hmac-md5`, `hmac-sha1`, `hmac-sha224`, `hmac-sha256`, `hmac-sha384`, and `hmac-sha512`. The default is `hmac-sha256`.

`-b keysize`

This option specifies the size of the authentication key in bits. The size must be between 1 and 512 bits; the default is the hash size.

**-c** *keyfile*

This option is used with the *-a* option to specify an alternate location for *rndc.key*.

**-h**

This option prints a short summary of the options and arguments to **rndc-confgen**.

**-k** *keyname*

This option specifies the key name of the *rndc* authentication key. This must be a valid domain name. The default is *rndc-key*.

**-p** *port*

This option specifies the command channel port where *named* listens for connections from *rndc*. The default is 953.

**-q**

This option prevents printing the written path in automatic configuration mode.

**-s** *address*

This option specifies the IP address where *named* listens for command-channel connections from *rndc*. The default is the loopback address 127.0.0.1.

**-t** *chrootdir*

This option is used with the *-a* option to specify a directory where *named* runs chrooted. An additional copy of the *rndc.key* is written relative to this directory, so that it is found by the chrooted *named*.

**-u** *user*

This option is used with the *-a* option to set the owner of the generated *rndc.key* file. If *-t* is also specified, only the file in the chroot area has its owner changed.

## 12.29.4 Examples

To allow *rndc* to be used with no manual configuration, run:

```
rndc-confgen -a
```

To print a sample *rndc.conf* file and the corresponding *controls* and *key* statements to be manually inserted into *named.conf*, run:

```
rndc-confgen
```

## 12.29.5 See Also

*rndc(8)*, *rndc.conf(5)*, *named(8)*, BIND 9 Administrator Reference Manual.

## 12.30 rndc.conf - rndc configuration file

### 12.30.1 Synopsis

```
rndc.conf
```

### 12.30.2 Description

**rndc.conf** is the configuration file for *rndc*, the BIND 9 name server control utility. This file has a similar structure and syntax to *named.conf*. Statements are enclosed in braces and terminated with a semi-colon. Clauses in the statements are also semi-colon terminated. The usual comment styles are supported:

C style: */\* \*/*

C++ style: // to end of line

Unix style: # to end of line

`rndc.conf` is much simpler than `named.conf`. The file uses three statements: an options statement, a server statement, and a key statement.

The `options` statement contains five clauses. The `default-server` clause is followed by the name or address of a name server. This host is used when no name server is given as an argument to `rndc`. The `default-key` clause is followed by the name of a key, which is identified by a `key` statement. If no `keyid` is provided on the `rndc` command line, and no `key` clause is found in a matching `server` statement, this default key is used to authenticate the server's commands and responses. The `default-port` clause is followed by the port to connect to on the remote name server. If no `port` option is provided on the `rndc` command line, and no `port` clause is found in a matching `server` statement, this default port is used to connect. The `default-source-address` and `default-source-address-v6` clauses can be used to set the IPv4 and IPv6 source addresses respectively.

After the `server` keyword, the server statement includes a string which is the hostname or address for a name server. The statement has three possible clauses: `key`, `port`, and `addresses`. The key name must match the name of a key statement in the file. The port number specifies the port to connect to. If an `addresses` clause is supplied, these addresses are used instead of the server name. Each address can take an optional port. If an `source-address` or `source-address-v6` is supplied, it is used to specify the IPv4 and IPv6 source address, respectively.

The `key` statement begins with an identifying string, the name of the key. The statement has two clauses. `algorithm` identifies the authentication algorithm for `rndc` to use; currently only HMAC-MD5 (for compatibility), HMAC-SHA1, HMAC-SHA224, HMAC-SHA256 (default), HMAC-SHA384, and HMAC-SHA512 are supported. This is followed by a `secret` clause which contains the base-64 encoding of the algorithm's authentication key. The base-64 string is enclosed in double quotes.

There are two common ways to generate the base-64 string for the secret. The BIND 9 program `rndc-confgen` can be used to generate a random key, or the `mmencode` program, also known as `mimencode`, can be used to generate a base-64 string from known input. `mmencode` does not ship with BIND 9 but is available on many systems. See the Example section for sample command lines for each.

### 12.30.3 Example

```
options {
    default-server localhost;
    default-key    samplekey;
};
```

```
server localhost {
    key          samplekey;
};
```

```
server testserver {
    key          testkey;
    addresses   { localhost port 5353; };
};
```

```
key samplekey {
    algorithm    hmac-sha256;
    secret       "6FMfj43Osz4lyb240Ie2iGEz9lf11lJO+lz";
};
```

```
key testkey {
    algorithm    hmac-sha256;
    secret       "R3HI8P6BKw9ZwXwN3VZKuQ==";
};
```

In the above example, *rndc* by default uses the server at localhost (127.0.0.1) and the key called "samplekey". Commands to the localhost server use the "samplekey" key, which must also be defined in the server's configuration file with the same name and secret. The key statement indicates that "samplekey" uses the HMAC-SHA256 algorithm and its secret clause contains the base-64 encoding of the HMAC-SHA256 secret enclosed in double quotes.

If *rndc -s testserver* is used, then *rndc* connects to the server on localhost port 5353 using the key "testkey".

To generate a random secret with *rndc-confgen*:

```
rndc-confgen
```

A complete **rndc.conf** file, including the randomly generated key, is written to the standard output. Commented-out key and controls statements for *named.conf* are also printed.

To generate a base-64 secret with *mmencode*:

```
echo "known plaintext for a secret" | mmencode
```

### 12.30.4 Name Server Configuration

The name server must be configured to accept *rndc* connections and to recognize the key specified in the **rndc.conf** file, using the controls statement in *named.conf*. See the sections on the controls statement in the BIND 9 Administrator Reference Manual for details.

### 12.30.5 See Also

*rndc* (8), *rndc-confgen* (8), *mmencode* (1), BIND 9 Administrator Reference Manual.

## 12.31 rndc - name server control utility

### 12.31.1 Synopsis

```
rndc [-b source-address] [-c config-file] [-k key-file] [-s server] [-p port] [-q] [-r] [-V] [-y server_key] [[-4] | [-6]]
{command}
```

### 12.31.2 Description

**rndc** controls the operation of a name server. If **rndc** is invoked with no command line options or arguments, it prints a short summary of the supported commands and the available options and their arguments.

**rndc** communicates with the name server over a TCP connection, sending commands authenticated with digital signatures. In the current versions of **rndc** and *named*, the only supported authentication algorithms are HMAC-MD5 (for compatibility), HMAC-SHA1, HMAC-SHA224, HMAC-SHA256 (default), HMAC-SHA384, and HMAC-SHA512. They use a shared secret on each end of the connection, which provides TSIG-style authentication for the command request and the name server's response. All commands sent over the channel must be signed by a server\_key known to the server.

**rndc** reads a configuration file to determine how to contact the name server and decide what algorithm and key it should use.

### 12.31.3 Options

**-4**

This option indicates use of IPv4 only.

**-6**

This option indicates use of IPv6 only.

**-b** *source-address*

This option indicates *source-address* as the source address for the connection to the server. Multiple instances are permitted, to allow setting of both the IPv4 and IPv6 source addresses.

**-c** *config-file*

This option indicates *config-file* as the configuration file instead of the default, `/usr/local/etc/rndc.conf`.

**-k** *key-file*

This option indicates *key-file* as the key file instead of the default, `/usr/local/etc/rndc.key`. The key in `/usr/local/etc/rndc.key` is used to authenticate commands sent to the server if the *config-file* does not exist.

**-s** *server*

*server* is the name or address of the server which matches a server statement in the configuration file for **rndc**. If no *server* is supplied on the command line, the host named by the `default-server` clause in the options statement of the **rndc** configuration file is used.

**-p** *port*

This option instructs BIND 9 to send commands to TCP port *port* instead of its default control channel port, 953.

**-q**

This option sets quiet mode, where message text returned by the server is not printed unless there is an error.

**-r**

This option instructs **rndc** to print the result code returned by *named* after executing the requested command (e.g., `ISC_R_SUCCESS`, `ISC_R_FAILURE`, etc.).

**-v**

This option enables verbose logging.

**-y** *server\_key*

This option indicates use of the key *server\_key* from the configuration file. For control message validation to succeed, *server\_key* must be known by *named* with the same algorithm and secret string. If no *server\_key* is specified, **rndc** first looks for a key clause in the server statement of the server being used, or if no server statement is present for that host, then in the `default-key` clause of the options statement. Note that the configuration file contains shared secrets which are used to send authenticated control commands to name servers, and should therefore not have general read or write access.

### 12.31.4 Commands

A list of commands supported by **rndc** can be seen by running **rndc** without arguments.

Currently supported commands are:

**addzone** *zone* [*class* [*view*]] *configuration*

This command adds a zone while the server is running. This command requires the `allow-new-zones` option to be set to `yes`. The configuration string specified on the command line is the zone configuration text that would ordinarily be placed in *named.conf*.

The configuration is saved in a file called `viewname.nzf` (or, if `named` is compiled with `liblmbd`, an LMDB database file called `viewname.nzd`). `viewname` is the name of the view, unless the view name contains characters that are incompatible with use as a file name, in which case a cryptographic hash of the view name is used instead. When `named` is restarted, the file is loaded into the view configuration so that zones that were added can persist after a restart.

This sample `addzone` command adds the zone `example.com` to the default view:

```
rndc addzone example.com '{ type primary; file "example.com.db"; }';
```

(Note the brackets around and semi-colon after the zone configuration text.)

See also `rndc delzone` and `rndc modzone`.

**delzone** [-clean] zone [class [view]]

This command deletes a zone while the server is running.

If the `-clean` argument is specified, the zone's master file (and journal file, if any) are deleted along with the zone. Without the `-clean` option, zone files must be deleted manually. (If the zone is of type `secondary` or `stub`, the files needing to be removed are reported in the output of the `rndc delzone` command.)

If the zone was originally added via `rndc addzone`, then it is removed permanently. However, if it was originally configured in `named.conf`, then that original configuration remains in place; when the server is restarted or reconfigured, the zone is recreated. To remove it permanently, it must also be removed from `named.conf`.

See also `rndc addzone` and `rndc modzone`.

**dnssec** (-status | -rollover -key id [-alg algorithm] [-when time] | -checkds [-key id\_ [-alg algorithm]] [-when time] published | withdrawn) zone [class [view]]

This command allows you to interact with the "dnssec-policy" of a given zone.

`rndc dnssec -status` show the DNSSEC signing state for the specified zone.

`rndc dnssec -rollover` allows you to schedule key rollover for a specific key (overriding the original key lifetime).

`rndc dnssec -checkds` informs `named` that the DS for a specified zone's key-signing key has been confirmed to be published in, or withdrawn from, the parent zone. This is required in order to complete a KSK rollover. The `-key id` and `-alg algorithm` arguments can be used to specify a particular KSK, if necessary; if there is only one key acting as a KSK for the zone, these arguments can be omitted. The time of publication or withdrawal for the DS is set to the current time by default, but can be overridden to a specific time with the argument `-when time`, where `time` is expressed in `YYYYMMDDHHMMSS` notation.

**dnstap** (-reopen | -roll [number])

This command closes and re-opens DNSTAP output files.

`rndc dnstap -reopen` allows the output file to be renamed externally, so that `named` can truncate and re-open it.

`rndc dnstap -roll` causes the output file to be rolled automatically, similar to log files. The most recent output file has ".0" appended to its name; the previous most recent output file is moved to ".1", and so on. If `number` is specified, then the number of backup log files is limited to that number.

**dumpdb** [-all | -cache | -zones | -adb | -bad | -expired | -fail] [view ...]

This command dumps the server's caches (default) and/or zones to the dump file for the specified views. If no view is specified, all views are dumped. (See the `dump-file` option in the BIND 9 Administrator Reference Manual.)

**flush**

This command flushes the server's cache.

**flushname** name [view]

This command flushes the given name from the view's DNS cache and, if applicable, from the view's nameserver address database, bad server cache, and SERVFAIL cache.

**flushtree** name [view]

This command flushes the given name, and all of its subdomains, from the view's DNS cache, address database, bad server cache, and SERVFAIL cache.

**freeze** [zone [class [view]]]

This command suspends updates to a dynamic zone. If no zone is specified, then all zones are suspended. This allows manual edits to be made to a zone normally updated by dynamic update, and causes changes in the journal file to be synced into the master file. All dynamic update attempts are refused while the zone is frozen.

See also *rndc thaw*.

**halt** [-p]

This command stops the server immediately. Recent changes made through dynamic update or IXFR are not saved to the master files, but are rolled forward from the journal files when the server is restarted. If `-p` is specified, *named*'s process ID is returned. This allows an external process to determine when *named* has completed halting.

See also *rndc stop*.

**loadkeys** [zone [class [view]]]

This command fetches all DNSSEC keys for the given zone from the key directory. If they are within their publication period, they are merged into the zone's DNSKEY RRset. Unlike *rndc sign*, however, the zone is not immediately re-signed by the new keys, but is allowed to incrementally re-sign over time.

This command requires that the zone be configured with a `dnssec-policy`, or that the `auto-dnssec` zone option be set to `maintain`, and also requires the zone to be configured to allow dynamic DNS. (See "Dynamic Update Policies" in the Administrator Reference Manual for more details.)

**managed-keys** (status | refresh | sync | destroy) [class [view]]

This command inspects and controls the "managed-keys" database which handles [RFC 5011](#) DNSSEC trust anchor maintenance. If a view is specified, these commands are applied to that view; otherwise, they are applied to all views.

- When run with the `status` keyword, this prints the current status of the managed-keys database.
- When run with the `refresh` keyword, this forces an immediate refresh query to be sent for all the managed keys, updating the managed-keys database if any new keys are found, without waiting the normal refresh interval.
- When run with the `sync` keyword, this forces an immediate dump of the managed-keys database to disk (in the file `managed-keys.bind` or `(viewname).mkeys`). This synchronizes the database with its journal file, so that the database's current contents can be inspected visually.
- When run with the `destroy` keyword, the managed-keys database is shut down and deleted, and all key maintenance is terminated. This command should be used only with extreme caution.

Existing keys that are already trusted are not deleted from memory; DNSSEC validation can continue after this command is used. However, key maintenance operations cease until *named* is restarted or reconfigured, and all existing key maintenance states are deleted.

Running *rndc reconfig* or restarting *named* immediately after this command causes key maintenance to be reinitialized from scratch, just as if the server were being started for the first time. This is primarily intended for testing, but it may also be used, for example, to jumpstart the acquisition of new keys in the event of a trust anchor rollover, or as a brute-force repair for key maintenance problems.

**modzone** zone [class [view]] configuration

This command modifies the configuration of a zone while the server is running. This command requires the `allow-new-zones` option to be set to `yes`. As with `addzone`, the configuration string specified on the command line is the zone configuration text that would ordinarily be placed in `named.conf`.

If the zone was originally added via `rndc addzone`, the configuration changes are recorded permanently and are still in effect after the server is restarted or reconfigured. However, if it was originally configured in `named.conf`, then that original configuration remains in place; when the server is restarted or reconfigured, the zone reverts to its original configuration. To make the changes permanent, it must also be modified in `named.conf`.

See also `rndc addzone` and `rndc delzone`.

**notify** zone [class [view]]

This command resends NOTIFY messages for the zone.

**notrace**

This command sets the server's debugging level to 0.

See also `rndc trace`.

**nta** [(-class class | -dump | -force | -remove | -lifetime duration)] domain [view]

This command sets a DNSSEC negative trust anchor (NTA) for `domain`, with a lifetime of `duration`. The default lifetime is configured in `named.conf` via the `nta-lifetime` option, and defaults to one hour. The lifetime cannot exceed one week.

A negative trust anchor selectively disables DNSSEC validation for zones that are known to be failing because of misconfiguration rather than an attack. When data to be validated is at or below an active NTA (and above any other configured trust anchors), `named` aborts the DNSSEC validation process and treats the data as insecure rather than bogus. This continues until the NTA's lifetime has elapsed.

NTAs persist across restarts of the `named` server. The NTAs for a view are saved in a file called `name.nta`, where `name` is the name of the view; if it contains characters that are incompatible with use as a file name, a cryptographic hash is generated from the name of the view.

An existing NTA can be removed by using the `-remove` option.

An NTA's lifetime can be specified with the `-lifetime` option. TTL-style suffixes can be used to specify the lifetime in seconds, minutes, or hours. If the specified NTA already exists, its lifetime is updated to the new value. Setting `lifetime` to zero is equivalent to `-remove`.

If `-dump` is used, any other arguments are ignored and a list of existing NTAs is printed. Note that this may include NTAs that are expired but have not yet been cleaned up.

Normally, `named` periodically tests to see whether data below an NTA can now be validated (see the `nta-recheck` option in the Administrator Reference Manual for details). If data can be validated, then the NTA is regarded as no longer necessary and is allowed to expire early. The `-force` parameter overrides this behavior and forces an NTA to persist for its entire lifetime, regardless of whether data could be validated if the NTA were not present.

The view class can be specified with `-class`. The default is class `IN`, which is the only class for which DNSSEC is currently supported.

All of these options can be shortened, i.e., to `-l`, `-r`, `-d`, `-f`, and `-c`.

Unrecognized options are treated as errors. To refer to a domain or view name that begins with a hyphen, use a double-hyphen (`--`) on the command line to indicate the end of options.

**querylog** [(on | off)]

This command enables or disables query logging. For backward compatibility, this command can also be used without an argument to toggle query logging on and off.

Query logging can also be enabled by explicitly directing the `queries` category to a channel in the logging section of `named.conf`, or by specifying `querylog yes`; in the `options` section of `named.conf`.

**reconfig**

This command reloads the configuration file and loads new zones, but does not reload existing zone files even if they have changed. This is faster than a full `rndc reload` when there is a large number of zones, because it avoids the need to examine the modification times of the zone files.

**recursing**

This command dumps the list of queries `named` is currently recursing on, and the list of domains to which iterative queries are currently being sent.

The first list includes all unique clients that are waiting for recursion to complete, including the query that is awaiting a response and the timestamp (seconds since the Unix epoch) of when `named` started processing this client query.

The second list comprises of domains for which there are active (or recently active) fetches in progress. It reports the number of active fetches for each domain and the number of queries that have been passed (allowed) or dropped (spilled) as a result of the `fetches-per-zone` limit. (Note: these counters are not cumulative over time; whenever the number of active fetches for a domain drops to zero, the counter for that domain is deleted, and the next time a fetch is sent to that domain, it is recreated with the counters set to zero).

**refresh** zone [class [view]]

This command schedules zone maintenance for the given zone.

**reload**

This command reloads the configuration file and zones.

**zone** [class [view]]

If a zone is specified, this command reloads only the given zone. If no zone is specified, the reloading happens asynchronously.

**retransfer** zone [class [view]]

This command retransfers the given secondary zone from the primary server.

If the zone is configured to use `inline-signing`, the signed version of the zone is discarded; after the retransfer of the unsigned version is complete, the signed version is regenerated with new signatures.

**scan**

This command scans the list of available network interfaces for changes, without performing a full `rndc reconfig` or waiting for the `interface-interval` timer.

**secreots** [-] [view ...]

This command dumps the security roots (i.e., trust anchors configured via `trust-anchors`, or the `managed-keys` or `trusted-keys` statements [both deprecated], or `dnssec-validation auto`) and negative trust anchors for the specified views. If no view is specified, all views are dumped. Security roots indicate whether they are configured as trusted keys, managed keys, or initializing managed keys (managed keys that have not yet been updated by a successful key refresh query).

If the first argument is `-`, then the output is returned via the `rndc` response channel and printed to the standard output. Otherwise, it is written to the `secreots` dump file, which defaults to `named.secreots`, but can be overridden via the `secreots-file` option in `named.conf`.

See also `rndc managed-keys`.

**serve-stale** (on | off | reset | status) [class [view]]

This command enables, disables, resets, or reports the current status of the serving of stale answers as configured in `named.conf`.

If serving of stale answers is disabled by `rndc-serve-stale off`, then it remains disabled even if `named` is reloaded or reconfigured. `rndc serve-stale reset` restores the setting as configured in `named.conf`.

`rndc serve-stale status` reports whether caching and serving of stale answers is currently enabled or disabled. It also reports the values of `stale-answer-ttl` and `max-stale-ttl`.

**showzone** zone [class [view]]

If the server is configured with `allow-new-zones` set to `yes`, then this command prints the configuration of a running zone.

See also `rndc addzone`, `rndc modzone`, and `rndc delzone`.

**sign** zone [class [view]]

This command fetches all DNSSEC keys for the given zone from the key directory (see the `key-directory` option in the BIND 9 Administrator Reference Manual). If they are within their publication period, they are merged into the zone's DNSKEY RRset. If the DNSKEY RRset is changed, then the zone is automatically re-signed with the new key set.

This command requires that the zone be configured with a `dnssec-policy`, or that the `auto-dnssec` zone option be set to `allow` or `maintain`, and also requires the zone to be configured to allow dynamic DNS. (See "Dynamic Update Policies" in the BIND 9 Administrator Reference Manual for more details.)

See also `rndc loadkeys`.

**signing** [(-list | -clear keyid/algorithm | -clear all | -nsec3param (parameters | none) | -serial value) zone [class [view]]

This command lists, edits, or removes the DNSSEC signing-state records for the specified zone. The status of ongoing DNSSEC operations, such as signing or generating NSEC3 chains, is stored in the zone in the form of DNS resource records of type `sig-signing-type`. `rndc signing -list` converts these records into a human-readable form, indicating which keys are currently signing or have finished signing the zone, and which NSEC3 chains are being created or removed.

`rndc signing -clear` can remove a single key (specified in the same format that `rndc signing -list` uses to display it), or all keys. In either case, only completed keys are removed; any record indicating that a key has not yet finished signing the zone is retained.

`rndc signing -nsec3param` sets the NSEC3 parameters for a zone. This is the only supported mechanism for using NSEC3 with `inline-signing` zones. Parameters are specified in the same format as an NSEC3PARAM resource record: `hash algorithm, flags, iterations, and salt`, in that order.

Currently, the only defined value for `hash algorithm` is 1, representing SHA-1. The `flags` may be set to 0 or 1, depending on whether the opt-out bit in the NSEC3 chain should be set. `iterations` defines the number of additional times to apply the algorithm when generating an NSEC3 hash. The `salt` is a string of data expressed in hexadecimal, a hyphen (-) if no salt is to be used, or the keyword `auto`, which causes `named` to generate a random 64-bit salt.

The only recommended configuration is `rndc signing -nsec3param 1 0 0 - zone`, i.e. no salt, no additional iterations, no opt-out.

 **Warning**

Do not use extra iterations, salt, or opt-out unless all their implications are fully understood. A higher number of iterations causes interoperability problems and opens servers to CPU-exhausting DoS attacks.

`rndc signing -nsec3param none` removes an existing NSEC3 chain and replaces it with NSEC.

`rndc signing -serial value` sets the serial number of the zone to `value`. If the value would cause the serial number to go backwards, it is rejected. The primary use of this parameter is to set the serial number on inline signed zones.

**stats**

This command writes server statistics to the statistics file. (See the `statistics-file` option in the BIND 9 Administrator Reference Manual.)

**status**

This command displays the status of the server. Note that the number of zones includes the internal `bind/CH` zone and the default `./IN` hint zone, if there is no explicit root zone configured.

**stop** `-p`

This command stops the server, making sure any recent changes made through dynamic update or IXFR are first saved to the master files of the updated zones. If `-p` is specified, `named`'s process ID is returned. This allows an external process to determine when `named` has completed stopping.

See also `rndc halt`.

**sync** `-clean` [`zone` [`class` [`view`]]]

This command syncs changes in the journal file for a dynamic zone to the master file. If the `"-clean"` option is specified, the journal file is also removed. If no zone is specified, then all zones are synced.

**tcp-timeouts** [`initial` `idle` `keepalive` `advertised`]

When called without arguments, this command displays the current values of the `tcp-initial-timeout`, `tcp-idle-timeout`, `tcp-keepalive-timeout`, and `tcp-advertised-timeout` options. When called with arguments, these values are updated. This allows an administrator to make rapid adjustments when under a denial-of-service (DoS) attack. See the descriptions of these options in the BIND 9 Administrator Reference Manual for details of their use.

**thaw** [`zone` [`class` [`view`]]]

This command enables updates to a frozen dynamic zone. If no zone is specified, then all frozen zones are enabled. This causes the server to reload the zone from disk, and re-enables dynamic updates after the load has completed. After a zone is thawed, dynamic updates are no longer refused. If the zone has changed and the `ixfr-from-differences` option is in use, the journal file is updated to reflect changes in the zone. Otherwise, if the zone has changed, any existing journal file is removed. If no zone is specified, the reloading happens asynchronously.

See also `rndc freeze`.

**trace** [`level`]

If no level is specified, this command increments the server's debugging level by one.

**level**

If specified, this command sets the server's debugging level to the provided value.

See also `rndc notrace`.

**tsig-delete** `keyname` [`view`]

This command deletes a given TKEY-negotiated key from the server. This does not apply to statically configured TSIG keys.

**tsig-list**

This command lists the names of all TSIG keys currently configured for use by `named` in each view. The list includes both statically configured keys and dynamic TKEY-negotiated keys.

**validation** (`on` | `off` | `status`) [`view` ...]

This command enables, disables, or checks the current status of DNSSEC validation. By default, validation is enabled.

The cache is flushed when validation is turned on or off to avoid using data that might differ between states.

**zonestatus** zone [class [view]]

This command displays the current status of the given zone, including the master file name and any include files from which it was loaded, when it was most recently loaded, the current serial number, the number of nodes, whether the zone supports dynamic updates, whether the zone is DNSSEC signed, whether it uses automatic DNSSEC key management or inline signing, and the scheduled refresh or expiry times for the zone.

See also *rndc showzone*.

**rndc** commands that specify zone names, such as *reload retransfer*, or *zonestatus*, can be ambiguous when applied to zones of type *redirect*. Redirect zones are always called *.*, and can be confused with zones of type *hint* or with secondary copies of the root zone. To specify a redirect zone, use the special zone name *-redirect*, without a trailing period. (With a trailing period, this would specify a zone called "-redirect".)

### 12.31.5 Limitations

There is currently no way to provide the shared secret for a *server\_key* without using the configuration file.

Several error messages could be clearer.

### 12.31.6 See Also

*rndc.conf(5)*, *rndc-confgen(8)*, *named(8)*, *named.conf(5)*, BIND 9 Administrator Reference Manual.

## 12.32 tsig-keygen - TSIG key generation tool

### 12.32.1 Synopsis

**tsig-keygen** [-a algorithm] [-h] [name]

### 12.32.2 Description

**tsig-keygen** is an utility that generates keys for use with TSIG (Transaction Signatures) as defined in [RFC 2845](#). The resulting keys can be used, for example, to secure dynamic DNS updates to a zone, or for the *rndc* command channel.

A domain name can be specified on the command line to be used as the name of the generated key. If no name is specified, the default is *tsig-key*.

### 12.32.3 Options

**-a** algorithm

This option specifies the algorithm to use for the TSIG key. Available choices are: *hmac-md5*, *hmac-sha1*, *hmac-sha224*, *hmac-sha256*, *hmac-sha384*, and *hmac-sha512*. The default is *hmac-sha256*. Options are case-insensitive, and the "hmac-" prefix may be omitted.

**-h**

This option prints a short summary of options and arguments.

### 12.32.4 See Also

*nsupdate(1)*, *named.conf(5)*, *named(8)*, BIND 9 Administrator Reference Manual.

## GENERAL DNS REFERENCE INFORMATION

### 13.1 Requests for Comment (RFCs)

Specification documents for the Internet protocol suite, including the DNS, are published as part of the Request for Comments (RFCs) series of technical notes. The standards themselves are defined by the Internet Engineering Task Force (IETF) and the Internet Engineering Steering Group (IESG). RFCs can be viewed online at: <https://www.rfc-editor.org/>.

While reading RFCs, please keep in mind that **not all RFCs are standards**, and also that the validity of documents does change over time. Every RFC needs to be interpreted in the context of other documents.

BIND 9 strives for strict compliance with IETF standards. To the best of our knowledge, BIND 9 complies with the following RFCs, with the caveats and exceptions listed in the numbered notes below. Many of these RFCs were written by current or former ISC staff members. The list is non-exhaustive.

Some of these RFCs, though DNS-related, are not concerned with implementing software.

#### 13.1.1 Protocol Specifications

**RFC 1034** - P. Mockapetris. *Domain Names — Concepts and Facilities*. November 1987.

**RFC 1035** - P. Mockapetris. *Domain Names — Implementation and Specification*. November 1987.<sup>12</sup>

**RFC 1183** - C. F. Everhart, L. A. Mamakos, R. Ullmann, P. Mockapetris. *New DNS RR Definitions*. October 1990.

**RFC 1521** - N. Borenstein, N. Freed - *MIME (Multipurpose Internet Mail Extensions) Part One: Mechanisms for Specifying and Describing the Format of Internet Message Bodies*. September 1993.<sup>17</sup>

**RFC 1706** - B. Manning and R. Colella. *DNS NSAP Resource Records*. October 1994.

**RFC 1712** - C. Farrell, M. Schulze, S. Pleitner, and D. Baldoni. *DNS Encoding of Geographical Location*. November 1994.

**RFC 1876** - C. Davis, P. Vixie, T. Goodwin, and I. Dickinson. *A Means for Expressing Location Information in the Domain Name System*. January 1996.

**RFC 1982** - R. Elz and R. Bush. *Serial Number Arithmetic*. August 1996.

**RFC 1995** - M. Ohta. *Incremental Zone Transfer in DNS*. August 1996.

**RFC 1996** - P. Vixie. *A Mechanism for Prompt Notification of Zone Changes (DNS NOTIFY)*. August 1996.

**RFC 2136** - P. Vixie, S. Thomson, Y. Rekhter, and J. Bound. *Dynamic Updates in the Domain Name System (DNS UPDATE)*. April 1997.

**RFC 2163** - A. Allocchio. *Using the Internet DNS to Distribute MIXER Conformant Global Address Mapping (MCGAM)*. January 1998.

---

<sup>1</sup> Queries to zones that have failed to load return SERVFAIL rather than a non-authoritative response. This is considered a feature.

<sup>2</sup> CLASS ANY queries are not supported. This is considered a feature.

<sup>17</sup> Only the Base 64 encoding specification is supported.

- RFC 2181** - R. Elz and R. Bush. *Clarifications to the DNS Specification*. July 1997.
- RFC 2230** - R. Atkinson. *Key Exchange Delegation Record for the DNS*. November 1997.
- RFC 2308** - M. Andrews. *Negative Caching of DNS Queries (DNS NCACHE)*. March 1998.
- RFC 2539** - D. Eastlake, 3rd. *Storage of Diffie-Hellman Keys in the Domain Name System (DNS)*. March 1999.
- RFC 2782** - A. Gulbrandsen, P. Vixie, and L. Esibov. *A DNS RR for Specifying the Location of Services (DNS SRV)*. February 2000.
- RFC 2930** - D. Eastlake, 3rd. *Secret Key Establishment for DNS (TKEY RR)*. September 2000.
- RFC 2931** - D. Eastlake, 3rd. *DNS Request and Transaction Signatures (SIG(0)s)*. September 2000.<sup>3</sup>
- RFC 3007** - B. Wellington. *Secure Domain Name System (DNS) Dynamic Update*. November 2000.
- RFC 3110** - D. Eastlake, 3rd. *RSA/SHA-1 SIGs and RSA KEYS in the Domain Name System (DNS)*. May 2001.
- RFC 3123** - P. Koch. *A DNS RR Type for Lists of Address Prefixes (APL RR)*. June 2001.
- RFC 3225** - D. Conrad. *Indicating Resolver Support of DNSSEC*. December 2001.
- RFC 3226** - O. Gudmundsson. *DNSSEC and IPv6 A6 Aware Server/Resolver Message Size Requirements*. December 2001.
- RFC 3363** - R. Bush, A. Durand, B. Fink, O. Gudmundsson, and T. Hain. *Representing Internet Protocol Version 6 (IPv6) Addresses in the Domain Name System (DNS)*. August 2002.<sup>15</sup>
- RFC 3403** - M. Mealling. *Dynamic Delegation Discovery System (DDDS). Part Three: The Domain Name System (DNS) Database*. October 2002.
- RFC 3492** - A. Costello. *Punycode: A Bootstring Encoding of Unicode for Internationalized Domain Names in Applications (IDNA)*. March 2003.<sup>18</sup>
- RFC 3493** - R. Gilligan, S. Thomson, J. Bound, J. McCann, and W. Stevens. *Basic Socket Interface Extensions for IPv6*. March 2003.
- RFC 3496** - A. G. Malis and T. Hsiao. *Protocol Extension for Support of Asynchronous Transfer Mode (ATM) Service Class-aware Multiprotocol Label Switching (MPLS) Traffic Engineering*. March 2003.
- RFC 3596** - S. Thomson, C. Huitema, V. Ksinant, and M. Souissi. *DNS Extensions to Support IP Version 6*. October 2003.
- RFC 3597** - A. Gustafsson. *Handling of Unknown DNS Resource Record (RR) Types*. September 2003.
- RFC 3645** - S. Kwan, P. Garg, J. Gilroy, L. Esibov, J. Westhead, and R. Hall. *Generic Security Service Algorithm for Secret Key Transaction Authentication for DNS (GSS-TSIG)*. October 2003.
- RFC 4025** - M. Richardson. *A Method for Storing IPsec Keying Material in DNS*. March 2005.
- RFC 4033** - R. Arends, R. Austein, M. Larson, D. Massey, and S. Rose. *DNS Security Introduction and Requirements*. March 2005.
- RFC 4034** - R. Arends, R. Austein, M. Larson, D. Massey, and S. Rose. *Resource Records for the DNS Security Extensions*. March 2005.
- RFC 4035** - R. Arends, R. Austein, M. Larson, D. Massey, and S. Rose. *Protocol Modifications for the DNS Security Extensions*. March 2005.
- RFC 4255** - J. Schlyter and W. Griffin. *Using DNS to Securely Publish Secure Shell (SSH) Key Fingerprints*. January 2006.

---

<sup>3</sup> Support for SIG(0) message verification was removed as part of the mitigation of CVE-2024-1975.

<sup>15</sup> Section 4 is ignored.

<sup>18</sup> BIND 9 requires `--with-libidn2` to enable entry of IDN labels within `dig`, `host`, and `nslookup` at compile time. ACE labels are supported everywhere with or without `--with-libidn2`.

- RFC 4343** - D. Eastlake, 3rd. *Domain Name System (DNS) Case Insensitivity Clarification*. January 2006.
- RFC 4398** - S. Josefsson. *Storing Certificates in the Domain Name System (DNS)*. March 2006.
- RFC 4470** - S. Weiler and J. Ihren. *Minimally covering NSEC Records and DNSSEC On-line Signing*. April 2006.<sup>6</sup>
- RFC 4509** - W. Hardaker. *Use of SHA-256 in DNSSEC Delegation Signer (DS) Resource Records (RRs)*. May 2006.
- RFC 4592** - E. Lewis. *The Role of Wildcards in the Domain Name System*. July 2006.
- RFC 4635** - D. Eastlake, 3rd. *HMAC SHA (Hashed Message Authentication Code, Secure Hash Algorithm) TSIG Algorithm Identifiers*. August 2006.
- RFC 4701** - M. Stapp, T. Lemon, and A. Gustafsson. *A DNS Resource Record (RR) for Encoding Dynamic Host Configuration Protocol (DHCP) Information (DHCID RR)*. October 2006.
- RFC 4955** - D. Blacka. *DNS Security (DNSSEC) Experiments*. July 2007.<sup>7</sup>
- RFC 5001** - R. Austein. *DNS Name Server Identifier (NSID) Option*. August 2007.
- RFC 5011** - M. StJohns. *Automated Updates of DNS Security (DNSSEC) Trust Anchors*.
- RFC 5155** - B. Laurie, G. Sisson, R. Arends, and D. Blacka. *DNS Security (DNSSEC) Hashed Authenticated Denial of Existence*. March 2008.
- RFC 5205** - P. Nikander and J. Laganier. *Host Identity Protocol (HIP) Domain Name System (DNS) Extension*. April 2008.
- RFC 5452** - A. Hubert and R. van Mook. *Measures for Making DNS More Resilient Against Forged Answers*. January 2009.<sup>8</sup>
- RFC 5702** - J. Jansen. *Use of SHA-2 Algorithms with RSA in DNSKEY and RRSIG Resource Records for DNSSEC*. October 2009.
- RFC 5891** - J. Klensin. *Internationalized Domain Names in Applications (IDNA): Protocol*. August 2010<sup>Page 516, 18</sup>
- RFC 5936** - E. Lewis and A. Hoenes, Ed. *DNS Zone Transfer Protocol (AXFR)*. June 2010.
- RFC 5952** - S. Kawamura and M. Kawashima. *A Recommendation for IPv6 Address Text Representation*. August 2010.
- RFC 6052** - C. Bao, C. Huitema, M. Bagnulo, M. Boucadair, and X. Li. *IPv6 Addressing of IPv4/IPv6 Translators*. October 2010.
- RFC 6147** - M. Bagnulo, A. Sullivan, P. Matthews, and I. van Beijnum. *DNS64: DNS Extensions for Network Address Translation from IPv6 Clients to IPv4 Servers*. April 2011.<sup>9</sup>
- RFC 6604** - D. Eastlake, 3rd. *xNAME RCODE and Status Bits Clarification*. April 2012.
- RFC 6605** - P. Hoffman and W. C. A. Wijngaards. *Elliptic Curve Digital Signature Algorithm (DSA) for DNSSEC*. April 2012.<sup>10</sup>
- RFC 6672** - S. Rose and W. Wijngaards. *DNAME Redirection in the DNS*. June 2012.
- RFC 6698** - P. Hoffman and J. Schlyter. *The DNS-Based Authentication of Named Entities (DANE) Transport Layer Security (TLS) Protocol: TLSA*. August 2012.
- RFC 6725** - S. Rose. *DNS Security (DNSSEC) DNSKEY Algorithm IANA Registry Updates*. August 2012.<sup>11</sup>
- RFC 6742** - RJ Atkinson, SN Bhatti, U. St. Andrews, and S. Rose. *DNS Resource Records for the Identifier-Locator Network Protocol (ILNP)*. November 2012.

<sup>6</sup> Minimally Covering NSEC records are accepted but not generated.

<sup>7</sup> BIND 9 interoperates with correctly designed experiments.

<sup>8</sup> *named* only uses ports to extend the ID space; addresses are not used.

<sup>9</sup> Section 5.5 does not match reality. *named* uses the presence of DO=1 to detect if validation may be occurring. CD has no bearing on whether validation occurs.

<sup>10</sup> Compliance is conditional on the OpenSSL library being linked against a supporting ECDSA.

<sup>11</sup> RSAMD5 support has been removed. See **RFC 8624**.

- RFC 6840** - S. Weiler, Ed., and D. Blacka, Ed. *Clarifications and Implementation Notes for DNS Security (DNSSEC)*. February 2013.<sup>12</sup>
- RFC 6891** - J. Damas, M. Graff, and P. Vixie. *Extension Mechanisms for DNS (EDNS(0))*. April 2013.
- RFC 7043** - J. Abley. *Resource Records for EUI-48 and EUI-64 Addresses in the DNS*. October 2013.
- RFC 7050** - T. Savolainen, J. Korhonen, and D. Wing. *Discovery of the IPv6 Prefix Used for IPv6 Address Synthesis*. November 2013.<sup>20</sup>
- RFC 7208** - S. Kitterman. *Sender Policy Framework (SPF) for Authorizing Use of Domains in Email, Version 1*. April 2014.
- RFC 7314** - M. Andrews. *Extension Mechanisms for DNS (EDNS) EXPIRE Option*. July 2014.
- RFC 7344** - W. Kumari, O. Gudmundsson, and G. Barwood. *Automating DNSSEC Delegation Trust Maintenance*. September 2014.<sup>13</sup>
- RFC 7477** - W. Hardaker. *Child-to-Parent Synchronization in DNS*. March 2015.
- RFC 7553** - P. Faltstrom and O. Kolkman. *The Uniform Resource Identifier (URI) DNS Resource Record*. June 2015.
- RFC 7583** - S. Morris, J. Ihren, J. Dickinson, and W. Mekking. *DNSSEC Key Rollover Timing Considerations*. October 2015.
- RFC 7766** - J. Dickinson, S. Dickinson, R. Bellis, A. Mankin, and D. Wessels. *DNS Transport over TCP - Implementation Requirements*. March 2016.
- RFC 7828** - P. Wouters, J. Abley, S. Dickinson, and R. Bellis. *The edns-tcp-keepalive EDNS0 Option*. April 2016.
- RFC 7830** - A. Mayrhofer. *The EDNS(0) Padding Option*. May 2016.<sup>14</sup>
- RFC 7858** - Z. Hu, L. Zhu, J. Heidemann, A. Mankin, D. Wessels, and P. Hoffman. *Specification for DNS over Transport Layer Security (TLS)*. May 2016.<sup>21</sup>
- RFC 7929** - P. Wouters. *DNS-Based Authentication of Named Entities (DANE) Bindings for OpenPGP*. August 2016.
- RFC 8078** - O. Gudmundsson and P. Wouters. *Managing DS Records from the Parent via CDS/CDNSKEY*. March 2017.<sup>22</sup>
- RFC 8080** - O. Sury and R. Edmonds. *Edwards-Curve Digital Security Algorithm (EdDSA) for DNSSEC*. February 2017.
- RFC 8484** - P. Hoffman and P. McManus. *DNS Queries over HTTPS (DoH)*. October 2018.<sup>21</sup>
- RFC 8509** - G. Huston, J. Damas, W. Kumari. *A Root Key Trust Anchor Sentinel for DNSSEC*. December 2018.
- RFC 8624** - P. Wouters and O. Sury. *Algorithm Implementation Requirements and Usage Guidance for DNSSEC*. June 2019.
- RFC 8659** - P. Hallam-Baker, R. Stradling, and J. Hoffman-Andrews. *DNS Certification Authority Authorization (CAA) Resource Record*. November 2019.
- RFC 8880** - S. Cheshire and D. Schinazi. *Special Use Domain Name 'ipv4only.arpa'*. August 2020.
- RFC 8945** - F. Dupont, S. Morris, P. Vixie, D. Eastlake 3rd, O. Gudmundsson, and B. Wellington. *Secret Key Transaction Authentication for DNS (TSIG)*. November 2020.
- RFC 9103** - W. Toorop, S. Dickinson, S. Sahib, P. Aras, and A. Mankin. *DNS Zone Transfer over TLS*. August 2021.<sup>23</sup>

---

<sup>12</sup> Section 5.9 - Always set CD=1 on queries. This is *not* done, as it prevents DNSSEC from working correctly through another recursive server.

When talking to a recursive server, the best algorithm is to send CD=0 and then send CD=1 iff SERVFAIL is returned, in case the recursive server has a bad clock and/or bad trust anchor. Alternatively, one can send CD=1 then CD=0 on validation failure, in case the recursive server is under attack or there is stale/bogus authoritative data.

<sup>20</sup> RFC 7050 is updated by RFC 8880.

<sup>13</sup> Updating of parent zones is not yet implemented.

<sup>14</sup> *named* does not currently encrypt DNS requests, so the PAD option is accepted but not returned in responses.

<sup>21</sup> Forwarding DNS queries over encrypted transports is not supported yet.

<sup>22</sup> Updating of parent zones is not yet implemented.

<sup>23</sup> Strict TLS and Mutual TLS authentication mechanisms are not supported yet.

**RFC 9432** - P. van Dijk, L. Peltan, O. Sury, W. Toorop, C.R. Monshouwer, P. Thomassen, A. Sargsyan. *DNS Catalog Zones*. July 2023.

**RFC 9460** - B. Schwartz, M. Bishop and E. Nygren, *Service Binding and Parameter Specification via the DNS (SVCB and HTTPS Resource Records)*. November 2023.<sup>24</sup>

### 13.1.2 Best Current Practice RFCs

**RFC 2219** - M. Hamilton and R. Wright. *Use of DNS Aliases for Network Services*. October 1997.

**RFC 2317** - H. Eidnes, G. de Groot, and P. Vixie. *Classless IN-ADDR.ARPA Delegation*. March 1998.

**RFC 2606** - D. Eastlake, 3rd and A. Panitz. *Reserved Top Level DNS Names*. June 1999.<sup>16</sup>

**RFC 3901** - A. Durand and J. Ihren. *DNS IPv6 Transport Operational Guidelines*. September 2004.

**RFC 5625** - R. Bellis. *DNS Proxy Implementation Guidelines*. August 2009.

**RFC 6303** - M. Andrews. *Locally Served DNS Zones*. July 2011.

**RFC 7793** - M. Andrews. *Adding 100.64.0.0/10 Prefixes to the IPv4 Locally-Served DNS Zones Registry*. May 2016.

**RFC 8906** - M. Andrews and R. Bellis. *A Common Operational Problem in DNS Servers: Failure to Communicate*. September 2020.

**RFC 9276** - W. Hardaker and V. Dukhovni. *Guidance for NSEC3 Parameter Settings*. August 2022.

### 13.1.3 For Your Information

**RFC 1101** - P. Mockapetris. *DNS Encoding of Network Names and Other Types*. April 1989.

**RFC 1123** - R. Braden. *Requirements for Internet Hosts - Application and Support*. October 1989.

**RFC 1535** - E. Gavron. *A Security Problem and Proposed Correction With Widely Deployed DNS Software*. October 1993.

**RFC 1536** - A. Kumar, J. Postel, C. Neuman, P. Danzig, and S. Miller. *Common DNS Implementation Errors and Suggested Fixes*. October 1993.

**RFC 1912** - D. Barr. *Common DNS Operational and Configuration Errors*. February 1996.

**RFC 2874** - M. Crawford and C. Huitema. *DNS Extensions to Support IPv6 Address Aggregation and Renumbering*. July 2000.<sup>4</sup>

**RFC 3833** - D. Atkins and R. Austein. *Threat Analysis of the Domain Name System (DNS)*. August 2004.

**RFC 4074** - Y. Morishita and T. Jinmei. *Common Misbehavior Against DNS Queries for IPv6 Addresses*. June 2005.

**RFC 4294** - J. Loughney, Ed. - *IPv6 Node Requirements*. April 2006.<sup>19</sup>

**RFC 4431** - M. Andrews and S. Weiler. *The DNSSEC Lookaside Validation (DLV) DNS Resource Record*. February 2006.<sup>5</sup>

**RFC 4892** - S. Woolf and D. Conrad. *Requirements for a Mechanism Identifying a Name Server Instance*. June 2007.

**RFC 6781** - O. Kolkman, W. Mekking, and R. Gieben. *DNSSEC Operational Practices, Version 2*. December 2012.

**RFC 7129** - R. Gieben and W. Mekking. *Authenticated Denial of Existence in the DNS*. February 2014.

**RFC 8749** - W. Mekking and D. Mahoney. *Moving DNSSEC Lookaside Validation (DLV) to Historic Status*. March 2020.

<sup>24</sup> Additional section processing is not supported for HTTPS and SVCB records.

<sup>16</sup> This does not apply to DNS server implementations.

<sup>4</sup> Compliance is with loading and serving of A6 records only. A6 records were moved to the experimental category by **RFC 3363**.

<sup>19</sup> Section 5.1 - DNAME records are fully supported.

<sup>5</sup> Compliance is with loading and serving of DLV records only. DLV records were moved to the historic category by **RFC 8749**.

## **13.2 Notes**

### **13.3 Internet Drafts**

Internet Drafts (IDs) are rough-draft working documents of the Internet Engineering Task Force (IETF). They are, in essence, RFCs in the preliminary stages of development. Implementors are cautioned not to regard IDs as archival, and they should not be quoted or cited in any formal documents unless accompanied by the disclaimer that they are "works in progress." IDs have a lifespan of six months, after which they are deleted unless updated by their authors.

## RELEASE NOTES

### Contents

- *Release Notes*
  - *Introduction*
  - *Supported Platforms*
  - *Download*
  - *Known Issues*
  - *Notes for BIND 9.18.47*
    - \* *Security Fixes*
  - *Notes for BIND 9.18.46*
    - \* *Bug Fixes*
  - *Notes for BIND 9.18.45*
    - \* *Feature Changes*
    - \* *Bug Fixes*
  - *Notes for BIND 9.18.44*
    - \* *Security Fixes*
    - \* *Bug Fixes*
  - *Notes for BIND 9.18.43*
    - \* *Bug Fixes*
  - *Notes for BIND 9.18.42*
    - \* *Bug Fixes*
  - *Notes for BIND 9.18.41*
    - \* *Security Fixes*
    - \* *New Features*
    - \* *Removed Features*
    - \* *Bug Fixes*

- *Notes for BIND 9.18.40*
- *Notes for BIND 9.18.39*
  - \* *New Features*
  - \* *Feature Changes*
  - \* *Bug Fixes*
- *Notes for BIND 9.18.38*
  - \* *Security Fixes*
  - \* *New Features*
  - \* *Bug Fixes*
- *Notes for BIND 9.18.37*
- *Notes for BIND 9.18.36*
  - \* *Feature Changes*
  - \* *Bug Fixes*
- *Notes for BIND 9.18.35*
  - \* *Bug Fixes*
- *Notes for BIND 9.18.34*
  - \* *New Features*
  - \* *Removed Features*
  - \* *Bug Fixes*
- *Notes for BIND 9.18.33*
  - \* *Security Fixes*
  - \* *New Features*
  - \* *Bug Fixes*
- *Notes for BIND 9.18.32*
  - \* *New Features*
  - \* *Removed Features*
  - \* *Feature Changes*
  - \* *Bug Fixes*
- *Notes for BIND 9.18.31*
  - \* *New Features*
  - \* *Feature Changes*
  - \* *Bug Fixes*
  - \* *Known Issues*
- *Notes for BIND 9.18.30*
  - \* *New Features*

- \* *Feature Changes*
- \* *Bug Fixes*
- \* *Known Issues*
- *Notes for BIND 9.18.29*
  - \* *Feature Changes*
  - \* *Bug Fixes*
  - \* *Known Issues*
- *Notes for BIND 9.18.28*
  - \* *Security Fixes*
  - \* *Bug Fixes*
  - \* *Known Issues*
- *Notes for BIND 9.18.27*
  - \* *New Features*
  - \* *Feature Changes*
  - \* *Known Issues*
- *Notes for BIND 9.18.26*
  - \* *New Features*
  - \* *Bug Fixes*
  - \* *Known Issues*
- *Notes for BIND 9.18.25*
  - \* *Bug Fixes*
  - \* *Known Issues*
- *Notes for BIND 9.18.24*
  - \* *Security Fixes*
  - \* *Bug Fixes*
  - \* *Known Issues*
- *Notes for BIND 9.18.23*
- *Notes for BIND 9.18.22*
- *Notes for BIND 9.18.21*
  - \* *Removed Features*
  - \* *Known Issues*
- *Notes for BIND 9.18.20*
  - \* *Feature Changes*
  - \* *Bug Fixes*
  - \* *Known Issues*

- *Notes for BIND 9.18.19*
  - \* *Security Fixes*
  - \* *Removed Features*
  - \* *Feature Changes*
  - \* *Bug Fixes*
  - \* *Known Issues*
- *Notes for BIND 9.18.18*
  - \* *Feature Changes*
  - \* *Bug Fixes*
  - \* *Known Issues*
- *Notes for BIND 9.18.17*
  - \* *Feature Changes*
  - \* *Bug Fixes*
  - \* *Known Issues*
- *Notes for BIND 9.18.16*
  - \* *Security Fixes*
  - \* *New Features*
  - \* *Removed Features*
  - \* *Bug Fixes*
  - \* *Known Issues*
- *Notes for BIND 9.18.15*
  - \* *Bug Fixes*
  - \* *Known Issues*
- *Notes for BIND 9.18.14*
  - \* *Removed Features*
  - \* *Bug Fixes*
  - \* *Known Issues*
- *Notes for BIND 9.18.13*
  - \* *New Features*
  - \* *Feature Changes*
  - \* *Bug Fixes*
  - \* *Known Issues*
- *Notes for BIND 9.18.12*
  - \* *Removed Features*
  - \* *Bug Fixes*

- \* *Known Issues*
- *Notes for BIND 9.18.11*
  - \* *Security Fixes*
  - \* *New Features*
  - \* *Removed Features*
  - \* *Feature Changes*
  - \* *Bug Fixes*
  - \* *Known Issues*
- *Notes for BIND 9.18.10*
  - \* *Feature Changes*
  - \* *Bug Fixes*
  - \* *Known Issues*
- *Notes for BIND 9.18.9*
  - \* *Bug Fixes*
  - \* *Known Issues*
- *Notes for BIND 9.18.8*
  - \* *Known Issues*
  - \* *New Features*
  - \* *Feature Changes*
  - \* *Bug Fixes*
- *Notes for BIND 9.18.7*
  - \* *Security Fixes*
  - \* *Feature Changes*
  - \* *Bug Fixes*
  - \* *Known Issues*
- *Notes for BIND 9.18.6*
  - \* *Feature Changes*
  - \* *Bug Fixes*
  - \* *Known Issues*
- *Notes for BIND 9.18.5*
  - \* *Feature Changes*
  - \* *Bug Fixes*
  - \* *Known Issues*
- *Notes for BIND 9.18.4*
  - \* *Feature Changes*

- \* *Bug Fixes*
- \* *Known Issues*
- *Notes for BIND 9.18.3*
  - \* *Security Fixes*
  - \* *Known Issues*
  - \* *New Features*
  - \* *Bug Fixes*
- *Notes for BIND 9.18.2*
  - \* *New Features*
  - \* *Bug Fixes*
  - \* *Known Issues*
- *Notes for BIND 9.18.1*
  - \* *Security Fixes*
  - \* *Feature Changes*
  - \* *Bug Fixes*
  - \* *Known Issues*
- *Notes for BIND 9.18.0*
  - \* *Known Issues*
  - \* *New Features*
  - \* *Removed Features*
  - \* *Feature Changes*
  - \* *Bug Fixes*
- *License*
- *End of Life*
- *Thank You*

## **14.1 Introduction**

BIND 9.18 (Extended Support Version) is a stable branch of BIND. This document summarizes significant changes since the last production release on that branch. Please see the *Changelog* file for a more detailed list of changes and bug fixes.

## 14.2 Supported Platforms

See the *Supported Platforms* section in the *Resource Requirements* chapter.

## 14.3 Download

The latest versions of BIND 9 software can always be found at <https://www.isc.org/download/>. There you will find additional information about each release, and source code.

## 14.4 Known Issues

The list of known issues affecting the latest version in the 9.18 branch can be found at <https://gitlab.isc.org/isc-projects/bind9/-/wikis/Known-Issues-in-BIND-9.18>

## 14.5 Notes for BIND 9.18.47

### 14.5.1 Security Fixes

- Fix unbounded NSEC3 iterations when validating referrals to unsigned delegations. (CVE-2026-1519)  
DNSSEC-signed zones may contain high iteration-count NSEC3 records, which prove that certain delegations are insecure. Previously, a validating resolver encountering such a delegation processed these iterations up to the number given, which could be a maximum of 65,535. This has been addressed by introducing a processing limit, set at 150. Now, if such an NSEC3 record is encountered, the delegation will be treated as insecure.  
ISC would like to thank Samy Medjahed/Ap4sh for bringing this vulnerability to our attention. [GL #5708]

## 14.6 Notes for BIND 9.18.46

### 14.6.1 Bug Fixes

- A stale answer could have been served in case of multiple upstream failures when following CNAME chains. This has been fixed. [GL #5751]

## 14.7 Notes for BIND 9.18.45

### 14.7.1 Feature Changes

- Update requirements for system test suite.  
Python 3.10 or newer is now required for running the system test suite. The required Python packages and their version requirements are now tracked in the file *bin/tests/system/requirements.txt*. [GL #5690] [GL #5614]

### 14.7.2 Bug Fixes

- Fix implementation of BRID and HHIT record types. [GL #5710]
- Fix implementation of DSYNC record type. [GL #5711]

## 14.8 Notes for BIND 9.18.44

### 14.8.1 Security Fixes

- Fix incorrect length checks for BRID and HHIT records. (CVE-2025-13878)

Malformed BRID and HHIT records could trigger an assertion failure. This has been fixed.

ISC would like to thank Vlatko Kosturjak from Marlink Cyber for bringing this vulnerability to our attention. [GL #5616]

### 14.8.2 Bug Fixes

- Allow glue in delegations with QTYPE=ANY.

When a query for type ANY triggered a delegation response, all additional data was omitted from the response, including mandatory glue. This has been fixed. [GL #5659]

- Reconfiguring an NSEC3 opt-out zone to NSEC caused the zone to be invalid.

A zone that was signed with NSEC3, had opt-out enabled, and was then reconfigured to use NSEC, was published with missing NSEC records. This has been fixed. [GL #5679]

## 14.9 Notes for BIND 9.18.43

### 14.9.1 Bug Fixes

- Adding NSEC3 opt-out records could leave invalid records in chain.

When creating an NSEC3 opt-out chain, a node in the chain could be removed too soon. The previous NSEC3 would therefore not be found, resulting in invalid NSEC3 records being left in the zone. This has been fixed. [GL #5671]

- AMTRELAY type 0 presentation format handling was wrong.

RFC 8777 specifies a placeholder value of . for the gateway field when the gateway type is 0 (no gateway). This was not being checked for, nor was it emitted when displaying the record. This has been corrected.

Instances of this record will need the placeholder period added to them when upgrading. [GL #5639]

## 14.10 Notes for BIND 9.18.42

### 14.10.1 Bug Fixes

- Skip unsupported algorithms when looking for a signing key.

A mix of supported and unsupported DNSSEC algorithms in the same zone could cause validation failures. Unsupported algorithms are now ignored when looking for signing keys. [GL #5622]

## 14.11 Notes for BIND 9.18.41

### 14.11.1 Security Fixes

- DNSSEC validation fails if matching but invalid DNSKEY is found. (CVE-2025-8677)

Previously, if a matching but cryptographically invalid key was encountered during DNSSEC validation, the key was skipped and not counted towards validation failures. *named* now treats such DNSSEC keys as hard failures and the DNSSEC validation fails immediately, instead of continuing with the next DNSKEYs in the RRset.

ISC would like to thank Zuyao Xu and Xiang Li from the All-in-One Security and Privacy Laboratory at Nankai University for bringing this vulnerability to our attention. [GL #5343]

- Address various spoofing attacks. (CVE-2025-40778)

Previously, several issues could be exploited to poison a DNS cache with spoofed records for zones which were not DNSSEC-signed or if the resolver was configured to not do DNSSEC validation. These issues were assigned CVE-2025-40778 and have now been fixed.

As an additional layer of protection, *named* no longer accepts DNAME records or extraneous NS records in the AUTHORITY section unless these are received via spoofing-resistant transport (TCP, UDP with DNS cookies, TSIG, or SIG(0)).

ISC would like to thank Yuxiao Wu, Yunyi Zhang, Baojun Liu, and Haixin Duan from Tsinghua University for bringing this vulnerability to our attention. [GL #5414]

- Cache-poisoning due to weak pseudo-random number generator. (CVE-2025-40780)

It was discovered during research for an upcoming academic paper that a xoshiro128\*\* internal state can be recovered by an external 3rd party, allowing the prediction of UDP ports and DNS IDs in outgoing queries. This could lead to an attacker spoofing the DNS answers with great efficiency and poisoning the DNS cache.

The internal random generator has been changed to a cryptographically secure pseudo-random generator.

ISC would like to thank Prof. Amit Klein and Omer Ben Simhon from Hebrew University of Jerusalem for bringing this vulnerability to our attention. [GL #5484]

### 14.11.2 New Features

- Support for parsing HHIT and BRID records has been added.

[GL #5444]

### 14.11.3 Removed Features

- Deprecate the "tkey-domain" statement.

Mark the *tkey-domain* statement as deprecated since it is only used by code implementing TKEY Mode 2 (Diffie-Hellman), which was removed from newer BIND 9 branches. [GL #4204]

- Deprecate the "tkey-gssapi-credential" statement.

The *tkey-gssapi-keytab* statement allows GSS-TSIG to be set up in a simpler and more reliable way than using the *tkey-gssapi-credential* statement and setting environment variables (e.g. KRB5\_KTNAME). Therefore, the *tkey-gssapi-credential* statement has been deprecated; *tkey-gssapi-keytab* should be used instead.

For configurations currently using a combination of both *tkey-gssapi-keytab* and *tkey-gssapi-credential*, the latter should be dropped and the keytab pointed to by *tkey-gssapi-keytab* should now only contain the credential previously specified by *tkey-gssapi-credential*. [GL #4204]

### 14.11.4 Bug Fixes

- Prevent spurious SERVFAILs for certain 0-TTL resource records.

Under certain circumstances, BIND 9 can return SERVFAIL when updating existing entries in the cache with new NS, A, AAAA, or DS records that have a TTL of zero. [GL #5294]

- Missing DNSSEC information when CD bit is set in query.

The RRSIGs for glue records were not being cached correctly for CD=1 queries. This has been fixed. [GL #5502]

## 14.12 Notes for BIND 9.18.40

### Note

The BIND 9.18.40 release was withdrawn after the discovery of a regression in a security fix in it during pre-release testing.

## 14.13 Notes for BIND 9.18.39

### 14.13.1 New Features

- Support for parsing the DSYNC record has been added.

[GL #5440]

### 14.13.2 Feature Changes

- Add deprecation warnings for RSASHA1, RSASHA1-NSEC3SHA1, and DS digest type 1.

RSASHA1 and RSASHA1-NSEC-SHA1 DNSKEY algorithms have been deprecated by the IETF and should no longer be used for DNSSEC. DS digest type 1 (SHA1) has also been deprecated in BIND 9. Validators are now expected to treat these algorithms and digest as unknown, resulting in some zones being treated as insecure when they were previously treated as secure. Warnings have been added to *named* and tools when these algorithms and this digest are being used for signing.

Zones signed with RSASHA1 or RSASHA1-NSEC-SHA1 should be migrated to a different DNSKEY algorithm.

Zones with DS or CDS records with digest type 1 (SHA1) should be updated to use a different digest type (e.g. SHA256) and the digest type 1 records should be removed. [GL #5358]

### 14.13.3 Bug Fixes

- Clean enough memory when adding new ADB names/entries under memory pressure.

The ADB memory cleaning is opportunistic even when BIND is under memory pressure (in the *overmem* condition). The opportunistic LRU cleaning and *overmem* cleaning have been split, and the *overmem* cleaning always cleans up double of the newly allocated *adbname*/*adbentry* to ensure we never allocate more memory than the assigned limit. [GL !10637]

- Rescan the interfaces again when reconfiguring the server.

Previously on FreeBSD, the server did not listen on the configured *localhost* interfaces immediately, but only after the *interface-interval* period had passed. After an earlier fix, the server would listen on the *localhost* after 60 minutes.

Now, the interfaces are rescanned immediately after configuring the *interface-interval* value and begin listening on the *localhost* interface immediately. [GL !10758]

## 14.14 Notes for BIND 9.18.38

### 14.14.1 Security Fixes

- Fix an issue when some specific queries could remain unanswered with *serve-stale* enabled.

When *named* was running with stale answers enabled and with the *stale-answer-client-timeout* configuration option set to 0, in certain situations it was possible that some queries could remain unanswered. This has been fixed. [GL #5383]

### 14.14.2 New Features

- Add support for the CO flag to *dig*.

Add support for Compact Denial of Existence to *dig*. This includes showing the CO (Compact Answers OK) flag when displaying messages and adding an option to set the CO flag when making queries (*dig +coflag*). [GL #5319]

### 14.14.3 Bug Fixes

- Correct the default *interface-interval* from 60s to 60m.

When the *interface-interval* parser was changed from a `uint32` parser to a duration parser, the default value stayed at plain number 60 which now means 60 seconds instead of 60 minutes. The documentation also incorrectly states that the value is in minutes. That has been fixed. [GL #5246]

- Fix a *purge-keys* bug when using multiple views of a zone.

Previously, when a DNSSEC key was purged by one zone view, other zone views would return an error about missing key files. This has been fixed. [GL #5315]

## 14.15 Notes for BIND 9.18.37

## 14.16 Notes for BIND 9.18.36

### 14.16.1 Feature Changes

- Make TLS data processing more reliable in various network conditions.

BIND now deciphers incoming TLS data before processing it, making it more similar to the handling of TCP. This results in a more predictable behavior, particularly when reading from the stream is paused or resumed. Previously, this could result in an assertion failure when using XFR over TLS (XoT). This has been fixed. [GL #5247]

### 14.16.2 Bug Fixes

- Stop caching lack of EDNS support.

*named* could falsely learn that a server did not support EDNS when a spoofed response was received; that subsequently prevented DNSSEC lookups from being made. This has been fixed. [GL #3949] [GL #5066]

- Fix resolver statistics counters for timed-out responses.

When query responses timed out, the resolver could incorrectly increase the regular response counters, even if no response was received. This has been fixed. [GL #5193]

- Don't enforce NOAUTH/NOCONF flags in DNSKEYs.

All DNSKEY keys are able to authenticate. The `DNS_KEYTYPE_NOAUTH` (and `DNS_KEYTYPE_NOCONF`) flags were defined for the KEY rdata type, and are not applicable to DNSKEY. Previously, however, because the DNSKEY implementation was built on top of KEY, the `_NOAUTH` flag prevented authentication in DNSKEYs as well. This has been corrected. [GL #5240]

- Fix inconsistency in CNAME/DNAME handling during resolution.

Previously, in some cases, the resolver could return rdatasets of type CNAME or DNAME without the result code being set to `DNS_R_CNAME` or `DNS_R_DNAME`. This could trigger an assertion failure. This has been fixed. [GL #5201]

## 14.17 Notes for BIND 9.18.35

### 14.17.1 Bug Fixes

- Fix deferred validation of unsigned DS and DNSKEY records.

When processing a query with the "checking disabled" bit set (`CD=1`), `named` stores the invalidated result in the cache, marked "pending". When the same query is sent with `CD=0`, the cached data is validated and either accepted as an answer, or ejected from the cache as invalid. This deferred validation was not attempted for DS and DNSKEY records if they had no cached signatures, causing spurious validation failures. The deferred validation is now completed in this scenario.

Also, if deferred validation fails, the data is now re-queried to find out whether the zone has been corrected since the invalid data was cached. [GL #5066]

- Fix RPZ race condition during a reconfiguration.

With RPZ in use, `named` could terminate unexpectedly because of a race condition when a reconfiguration command was received using `rndc`. This has been fixed. [GL #5146]

- "CNAME and other data check" not applied to all types.

An incorrect optimization caused "CNAME and other data" errors not to be detected if certain types were at the same node as a CNAME. This has been fixed. [GL #5150]

- Remove NSEC/DS/NSEC3 RRSIG check from `dns_message_parse()`.

Previously, when parsing responses, `named` incorrectly rejected responses without matching RRSIG records for NSEC/DS/NSEC3 records in the authority section. This rejection, if appropriate, should have been left for the validator to determine and has been fixed. [GL #5185]

## 14.18 Notes for BIND 9.18.34

### 14.18.1 New Features

- Print the expiration time of the stale records.

Print the expiration time of the stale RRsets in the cache dump.

### 14.18.2 Removed Features

- Remove `--with-tuning=small/large` configuration option.

The configuration option `--with-tuning` has been removed as it is no longer required or desired.

### 14.18.3 Bug Fixes

- Fix `rndc flushname` for longer name server names.

`rndc flushname` did not work for name server names longer than 16 bytes. This has been fixed. [GL #3885]

- Recently expired records could be returned with a timestamp in future.

Under rare circumstances, an RRSet that expired at the time of the query could be returned with a TTL in the future. This has been fixed.

As a side effect, the expiration time of expired RRsets is no longer returned in a cache dump. [GL #5094]

- YAML string not terminated in negative response in delv.

[GL #5098]

- Apply the memory limit only to ADB database items.

Under heavy load, a resolver could exhaust the memory available for storing the information in the Address Database (ADB), effectively discarding previously stored information in the ADB. The memory used to retrieve and provide information from the ADB is no longer subject to the same memory limits that are applied to

the Address Database. [GL #5127]

- Avoid unnecessary locking in the zone/cache database.

Lock contention among many worker threads referring to the same database node at the same time is now prevented. This improves zone and cache database performance for any heavily contended database nodes. [GL #5130]

- Improve the resolver performance under attack.

Previously, a remote client could force the DNS resolver component to consume memory faster than resources were cleaned up for the canceled resolver fetches, due to the *recursive-clients* limit. If such a traffic pattern was sustained for a long period of time, the DNS server might eventually run out of the available memory. This has been fixed.

It should be noted that, under such a heavy attack, no outgoing DNS queries will be successful in BIND 9 versions both with and without the fix, as the generated traffic pattern will consume all the available slots for the recursive clients.

## 14.19 Notes for BIND 9.18.33

### 14.19.1 Security Fixes

- DNS-over-HTTPS flooding fixes. (CVE-2024-12705)

Fix DNS-over-HTTPS implementation issues that arise under heavy query load. Optimize resource usage for *named* instances that accept queries over DNS-over-HTTPS.

Previously, *named* processed all incoming HTTP/2 data at once, which could overwhelm the server, especially when dealing with clients that sent requests but did not wait for responses. That has been fixed. Now, *named* handles HTTP/2 data in smaller chunks and throttles reading until the remote side reads the response data. It also throttles clients that send too many requests at once.

In addition, *named* now evaluates excessive streams opened by clients that include no DNS data, which is considered "flooding." It logs these clients and drops connections from them. [GL #4795]

In some cases, *named* could leave DNS-over-HTTPS connections in the *CLOSE\_WAIT* state indefinitely. That has also been fixed. [GL #5083]

ISC would like to thank Jean-François Billaud for his assistance with investigating this issue.

- Limit additional section processing for large RDATA sets. (CVE-2024-11187)

When answering queries, don't add data to the additional section if the answer has more than 13 names in the RDATA. This limits the number of lookups into the database(s) during a single client query, reducing the query-processing load. [GL #5034]

ISC would like to thank Toshifumi Sakaguchi for bringing this vulnerability to our attention.

### 14.19.2 New Features

- Add a new option to configure the maximum number of outgoing queries per client request.

The configuration option `max-query-count` sets how many outgoing queries per client request are allowed. The existing `max-recursion-queries` value is the number of permissible queries for a single name and is reset on every CNAME redirection. This new option is a global limit on the client request. The default is 200.

The default for `max-recursion-queries` is changed from 32 to 50. This allows `named` to send a few more queries while looking up a single name. [GL #4980] [GL #4921]

### 14.19.3 Bug Fixes

- Fix `nsupdate` hang when processing a large update.

To mitigate DNS flood attacks over a single TCP connection, throttle the connection when the other side does not read the data. Throttling should only occur on server-side sockets, but erroneously also happened for `nsupdate`, which acts as a client. When `nsupdate` started throttling the connection, it never attempted to read again. This has been fixed. [GL #4910]

- Fix possible assertion failure when reloading server while processing update policy rules. [GL #5006]
- Fix `dnssec-signzone` signing non-DNSKEY RRsets with revoked keys.

`dnssec-signzone` was using revoked keys for signing RRsets other than DNSKEY. This has been corrected. [GL #5070]

- Fix improper handling of unknown directives in `resolv.conf`.

The line after an unknown directive in `resolv.conf` could accidentally be skipped, potentially affecting `dig`, `host`, `nslookup`, `nsupdate`, or `delv`. This has been fixed. [GL #5084]

## 14.20 Notes for BIND 9.18.32

### 14.20.1 New Features

- Update built-in `bind.keys` file with the new 2025 IANA root key.

Add an `initial-ds` entry to `bind.keys` for the new root key, ID 38696, which is scheduled for publication in January 2025. [GL #4896]

### 14.20.2 Removed Features

- Move contributed DLZ modules into a separate repository. DLZ modules should not be used except in testing.

The DLZ modules were not maintained, the DLZ interface itself is going to be scheduled for removal, and the DLZ interface is blocking. Any module that blocks the query to the `database` blocks the whole server.

The DLZ modules now live in <https://gitlab.isc.org/isc-projects/dlz-modules> repository. [GL #4865]

### 14.20.3 Feature Changes

- Emit more helpful log messages for exceeding `max-records-per-type`.

The new log message is emitted when adding or updating an RRset fails due to exceeding the `max-records-per-type` limit. The log includes the owner name and type, corresponding zone name, and the limit value. It will be emitted on loading a zone file, inbound zone transfer (both AXFR and IXFR), handling a DDNS update, or updating a cache DB. It's especially helpful in the case of zone transfer, since the secondary side doesn't have direct access to the offending zone data.

It could also be used for *max-types-per-name*, but this change doesn't implement it yet as it's much less likely to happen in practice.

- Harden key management when key files have become unavailable.

Prior to doing key management, BIND 9 will check if the key files on disk match the expected keys. If key files for previously observed keys have become unavailable, this will prevent the internal key manager from running.

## 14.20.4 Bug Fixes

- *{&dns}* is as valid as *{?dns}* in a SVCB's dohpath.

*dig* failed to parse a valid SVCB record with a *dohpath* URI template containing a *{&dns}*, like *doh-path=/some/path?key=value{&dns}*". [GL #4922]

- Fix NSEC3 closest enclosure lookup for names with empty non-terminals.

A previous performance optimization for finding the NSEC3 closest enclosure when generating authoritative responses could cause servers to return incorrect NSEC3 records in some cases. This faulty optimization has been removed. [GL #4950]

- *dig* options of the form *[+/-]option=<value>* failed to display the value on the printed command line. This has been fixed. [GL #4993]
- Provide more visibility into TLS configuration errors by logging *SSL\_CTX\_use\_certificate\_chain\_file()* and *SSL\_CTX\_use\_PrivateKey\_file()* errors individually. [GL #5008]

## 14.21 Notes for BIND 9.18.31

### 14.21.1 New Features

- Added WALLET type.

Add the new record type WALLET (262). This provides a mapping from a domain name to a cryptographic currency wallet. Multiple mappings can exist if multiple records exist. [GL #4947]

### 14.21.2 Feature Changes

- Allow IXFR-to-AXFR fallback on `DNS_R_TOOMANYRECORDS`.

This change allows fallback from an IXFR failure to AXFR when the reason is `DNS_R_TOOMANYRECORDS`. [GL #4928]

### 14.21.3 Bug Fixes

- Fix a statistics channel counter bug when "forward only" zones are used.

When resolving a zone with a "forward only" policy, and finding out that all the forwarders were marked as "bad", the "ServerQuota" counter of the statistics channel was incorrectly increased. This has been fixed. [GL #1793]

- Fix a bug in the static-stub implementation.

Static-stub addresses and addresses from other sources were being mixed together, resulting in static-stub queries going to addresses not specified in the configuration, or alternatively, static-stub addresses being used instead of the correct server addresses. [GL #4850]

- Don't allow *statistics-channels* if *libxml2* and *libjson-c* are not configured.

When BIND 9 is not configured with the *libxml2* and *libjson-c* libraries, the use of the *statistics-channels* option is a fatal error. [GL #4895]

- Limit the outgoing UDP send queue size.

If the operating system UDP queue got full and the outgoing UDP sending started to be delayed, BIND 9 could exhibit memory spikes as it tried to enqueue all the outgoing UDP messages. It now tries to deliver the outgoing UDP messages synchronously; if that fails, it drops the outgoing DNS message that would get queued up and then timeout on the client side. [GL #4930]

- Do not set `SO_INCOMING_CPU`.

Remove the `SO_INCOMING_CPU` setting as kernel scheduling performs better without constraints. [GL #4936]

### 14.21.4 Known Issues

- There are no new known issues with this release. See *above* for a list of all known issues affecting this BIND 9 branch.

## 14.22 Notes for BIND 9.18.30

### 14.22.1 New Features

- Print the full path of the working directory in startup log messages.

*named* now prints its initial working directory during startup, and the changed working directory when loading or reloading its configuration file, if it has a valid *directory* option defined. [GL #4731]

### 14.22.2 Feature Changes

- Improve performance for queries that require an NSEC3 wildcard proof.

Rather than starting from the longest matching part of the requested name, lookup the shortest partial match. Most of the time this will be the actual closest encloser. [GL #4460]

- Follow the number of CPUs set by `taskset/cpuset`.

Administrators may wish to constrain the set of cores that *named* runs on via the `taskset`, `cpuset`, or `numactl` programs (or equivalents on other OSes).

If the admin has used `taskset`, *named* now automatically uses the given number of CPUs rather than the system-wide count. [GL #4884]

### 14.22.3 Bug Fixes

- Verification of the privacy of an EDDSA key was broken.

The check could lead to an attempt to sign records with a public key, which could cause a segmentation failure (read of a NULL pointer) within OpenSSL. This has been fixed. [GL #4855]

- Fix algorithm rollover bug when there are two keys with the same keytag.

If there was an algorithm rollover and two keys of different algorithms shared the same keytags, there was the possibility that the check of whether the key matched a specific state could be performed against the wrong key. This has been fixed by not only checking for the matching key tag but also the key algorithm. [GL #4878]

### 14.22.4 Known Issues

- There are no new known issues with this release. See *above* for a list of all known issues affecting this BIND 9 branch.

## 14.23 Notes for BIND 9.18.29

### 14.23.1 Feature Changes

- Tighten *max-recursion-queries* and add *max-query-restarts* configuration statement.

There were cases when the *max-recursion-queries* quota was ineffective. It was possible to craft zones that would cause a resolver to waste resources by sending excessive queries while attempting to resolve a name. This has been addressed by correcting errors in the implementation of *max-recursion-queries* and by reducing the default value from 100 to 32.

In addition, a new *max-query-restarts* configuration statement has been added, which limits the number of times a recursive server will follow CNAME or DNAME records before terminating resolution. This was previously a hard-coded limit of 16 but is now configurable with a default value of 11.

ISC would like to thank Huayi Duan, Marco Bearzi, Jodok Vieli, and Cagin Tanir from NetSec group, ETH Zurich for discovering and notifying us about the issue. [GL #4741] [GL !9283]

- Raise the log level of priming failures.

When a priming query is complete, it was previously logged at level `DEBUG (1)`, regardless of success or failure. It is now logged to `NOTICE` in the case of failure. [GL #3516] [GL !9251]

- Add a compatibility shim for older libuv versions (< 1.19.0)

The function `uv_stream_get_write_queue_size()` is supported only in relatively new versions of libuv (1.19.0 or higher). Provide a compatibility shim for this function so BIND 9 can be built in environments with older libuv versions.

### 14.23.2 Bug Fixes

- Return `SERVFAIL` for a too long CNAME chain.

When following long CNAME chains, *named* was returning `NOERROR` (along with a partial answer) instead of `SERVFAIL`, if the chain exceeded the maximum length. This has been fixed. [GL #4449] [GL !9204]

- Reconfigure *catz* member zones during *named* reconfiguration.

During a reconfiguration, *named* wasn't reconfiguring catalog zones' member zones. This has been fixed. [GL #4733]

- Update key lifetime and metadata after *dnssec-policy* reconfiguration.

Adjust key state and timing metadata if *dnssec-policy* key lifetime configuration is updated, so that it also affects existing keys. [GL #4677] [GL !9192]

- Fix generation of 6to4-self name expansion from IPv4 address.

The period between the most significant nibble of the encoded IPv4 address and the `2.0.0.2.IP6.ARPA` suffix was missing, resulting in the wrong name being checked. This has been fixed. [GL #4766] [GL !9218]

- *dig +yaml* was producing unexpected and/or invalid YAML. output. [GL #4796] [GL !9214]

- SVBC ALPN text parsing failed to reject zero-length ALPN. [GL #4775] [GL !9210]

- Fix false QNAME minimisation error being reported.

Remove the false positive `success resolving` log message when QNAME minimisation is in effect and the final result is an `NXDOMAIN`. [GL #4784] [GL !9216]

- Fix *dig +timeout* argument when using *+https*.

The *+timeout* argument was not used on DoH connections. This has been fixed. [GL #4806] [GL !9161]

### 14.23.3 Known Issues

- There are no new known issues with this release. See *above* for a list of all known issues affecting this BIND 9 branch.

## 14.24 Notes for BIND 9.18.28

### 14.24.1 Security Fixes

- A malicious DNS client that sent many queries over TCP but never read the responses could cause a server to respond slowly or not at all for other clients. This has been fixed. (CVE-2024-0760) [GL #4481]
- It is possible to craft excessively large resource records sets, which have the effect of slowing down database processing. This has been addressed by adding a configurable limit to the number of records that can be stored per name and type in a cache or zone database. The default is 100, which can be tuned with the new *max-records-per-type* option. [GL #497] [GL #3405]

It is possible to craft excessively large numbers of resource record types for a given owner name, which has the effect of slowing down database processing. This has been addressed by adding a configurable limit to the number of records that can be stored per name and type in a cache or zone database. The default is 100, which can be tuned with the new *max-types-per-name* option. (CVE-2024-1737) [GL #3403]

ISC would like to thank Toshifumi Sakaguchi who independently discovered and responsibly reported the issue to ISC. [GL #4548]

- Validating DNS messages signed using the SIG(0) protocol (RFC 2931) could cause excessive CPU load, leading to a denial-of-service condition. Support for SIG(0) message validation was removed from this version of *named*. (CVE-2024-1975) [GL #4480]
- Due to a logic error, lookups that triggered serving stale data and required lookups in local authoritative zone data could have resulted in an assertion failure. This has been fixed. (CVE-2024-4076) [GL #4507]
- Potential data races were found in our DoH implementation, related to HTTP/2 session object management and endpoints set object management after reconfiguration. These issues have been fixed. [GL #4473]

ISC would like to thank Dzintars and Ivo from nic.lv for bringing this to our attention.

- When looking up the NS records of parent zones as part of looking up DS records, it was possible for *named* to trigger an assertion failure if *serve-stale* was enabled. This has been fixed. [GL #4661]

### 14.24.2 Bug Fixes

- Command-line options for IPv4-only (*named -4*) and IPv6-only (*named -6*) modes are now respected for zone *primaries*, *also-notify*, and *parental-agents*. [GL #3472]
- An RPZ response's SOA record TTL was set to 1 instead of the SOA TTL, if *add-soa* was used. This has been fixed. [GL #3323]
- When a query related to zone maintenance (NOTIFY, SOA) timed out close to a view shutdown (triggered e.g. by *rndc reload*), *named* could crash with an assertion failure. This has been fixed. [GL #4719]
- The statistics channel counters that indicated the number of currently connected TCP IPv4/IPv6 clients were not properly adjusted in certain failure scenarios. This has been fixed. [GL #4742]
- Some servers that could not be reached due to EHOSTDOWN or ENETDOWN conditions were incorrectly prioritized during server selection. These are now properly handled as unreachable. [GL #4736]
- On some systems the *libuv* call may return an error code when sending a TCP reset for a connection, which triggers an assertion failure in *named*. This error condition is now dealt with in a more graceful manner, by logging the incident and shutting down the connection. [GL #4708]

### 14.24.3 Known Issues

- There are no new known issues with this release. See *above* for a list of all known issues affecting this BIND 9 branch.

## 14.25 Notes for BIND 9.18.27

### 14.25.1 New Features

- A new option `signatures-jitter` has been added to `dnssec-policy` to allow signature expirations to be spread out over a period of time. [GL #4554]

### 14.25.2 Feature Changes

- DNSSEC signatures that are not valid because the current time falls outside the signature inception and expiration dates are skipped instead of causing an immediate validation failure. [GL #4586]

### 14.25.3 Known Issues

- There are no new known issues with this release. See *above* for a list of all known issues affecting this BIND 9 branch.

## 14.26 Notes for BIND 9.18.26

### 14.26.1 New Features

- The statistics channel now includes counters that indicate the number of currently connected TCP IPv4/IPv6 clients. [GL #4425]
- Added RESOLVER.ARPA to the built in empty zones. [GL #4580]

### 14.26.2 Bug Fixes

- Changes to `listen-on` statements were ignored on reconfiguration unless the port or interface address was changed, making it impossible to change a related listener transport type. That issue has been fixed.  
ISC would like to thank Thomas Amgarten for bringing this issue to our attention. [GL #4518] [GL #4528]
- A bug in the `keymgr` code unintentionally slowed down some DNSSEC key rollovers. This has been fixed. [GL #4552]
- Some ISO 8601 durations were accepted erroneously, leading to shorter durations than expected. This has been fixed. [GL #4624]

### 14.26.3 Known Issues

- There are no new known issues with this release. See *above* for a list of all known issues affecting this BIND 9 branch.

## 14.27 Notes for BIND 9.18.25

### 14.27.1 Bug Fixes

- A regression in cache-cleaning code enabled memory use to grow significantly more quickly than before, until the configured `max-cache-size` limit was reached. This has been fixed. [GL #4596]

- Using `rndc flush` inadvertently caused cache cleaning to become less effective. This could ultimately lead to the configured `max-cache-size` limit being exceeded and has now been fixed. [GL #4621]
- The logic for cleaning up expired cached DNS records was tweaked to be more aggressive. This change helps with enforcing `max-cache-ttl` and `max-ncache-ttl` in a timely manner. [GL #4591]
- It was possible to trigger a use-after-free assertion when the overmem cache cleaning was initiated. This has been fixed. [GL #4595]

ISC would like to thank Jinmei Tatuya of Infoblox for bringing this issue to our attention.

## 14.27.2 Known Issues

- There are no new known issues with this release. See *above* for a list of all known issues affecting this BIND 9 branch.

## 14.28 Notes for BIND 9.18.24

### 14.28.1 Security Fixes

- Validating DNS messages containing a lot of DNSSEC signatures could cause excessive CPU load, leading to a denial-of-service condition. This has been fixed. (CVE-2023-50387)

ISC would like to thank Elias Heftrig, Haya Schulmann, Niklas Vogel, and Michael Waidner from the German National Research Center for Applied Cybersecurity ATHENE for bringing this vulnerability to our attention. [GL #4424]

- Preparing an NSEC3 closest encloser proof could cause excessive CPU load, leading to a denial-of-service condition. This has been fixed. (CVE-2023-50868) [GL #4459]
- Parsing DNS messages with many different names could cause excessive CPU load. This has been fixed. (CVE-2023-4408)

ISC would like to thank Shoham Danino from Reichman University, Anat Bremler-Barr from Tel-Aviv University, Yehuda Afek from Tel-Aviv University, and Yuval Shavitt from Tel-Aviv University for bringing this vulnerability to our attention. [GL #4234]

- Specific queries could cause `named` to crash with an assertion failure when `nxdomain-redirect` was enabled. This has been fixed. (CVE-2023-5517) [GL #4281]
- A bad interaction between DNS64 and `serve-stale` could cause `named` to crash with an assertion failure, when both of these features were enabled. This has been fixed. (CVE-2023-5679) [GL #4334]
- Under certain circumstances, the DNS-over-TLS client code incorrectly attempted to process more than one DNS message at a time, which could cause `named` to crash with an assertion failure. This has been fixed. [GL #4487]

### 14.28.2 Bug Fixes

- The counters exported via the statistics channel were changed back to 64-bit signed values; they were being inadvertently truncated to unsigned 32-bit values since BIND 9.15.0. [GL #4467]

### 14.28.3 Known Issues

- There are no new known issues with this release. See *above* for a list of all known issues affecting this BIND 9 branch.

## 14.29 Notes for BIND 9.18.23

### Note

The BIND 9.18.23 release was withdrawn after the discovery of a regression in a security fix in it during pre-release testing. ISC would like to acknowledge the assistance of Vinzenz Vogel and Daniel Stirnimann of SWITCH.

## 14.30 Notes for BIND 9.18.22

### Note

The BIND 9.18.22 release was withdrawn after the discovery of a regression in a security fix in it during pre-release testing. ISC would like to acknowledge the assistance of Curtis Tuplin of SaskTel.

## 14.31 Notes for BIND 9.18.21

### 14.31.1 Removed Features

- Support for using AES as the DNS COOKIE algorithm (`cookie-algorithm aes;`) has been deprecated and will be removed in a future release. Please use the current default, SipHash-2-4, instead. [GL #4421]
- The `resolver-nonbackoff-tries` and `resolver-retry-interval` statements have been deprecated. Using them now causes a warning to be logged. [GL #4405]

### 14.31.2 Known Issues

- There are no new known issues with this release. See *above* for a list of all known issues affecting this BIND 9 branch.

## 14.32 Notes for BIND 9.18.20

### 14.32.1 Feature Changes

- The IP addresses for B.ROOT-SERVERS.NET have been updated to 170.247.170.2 and 2801:1b8:10::b. [GL #4101]

### 14.32.2 Bug Fixes

- If the unsigned version of an inline-signed zone contained DNSSEC records, it was incorrectly scheduled for resigning. This has been fixed. [GL #4350]
- Looking up stale data from the cache did not take local authoritative data into account. This has been fixed. [GL #4355]
- An assertion failure was triggered when `lock-file` was used at the same time as the `named -X` command-line option. This has been fixed. [GL #4386]
- The `lock-file` file was being removed when it should not have been, making the statement ineffective when `named` was started three or more times. This has been fixed. [GL #4387]

### 14.32.3 Known Issues

- There are no new known issues with this release. See *above* for a list of all known issues affecting this BIND 9 branch.

## 14.33 Notes for BIND 9.18.19

### 14.33.1 Security Fixes

- Previously, sending a specially crafted message over the control channel could cause the packet-parsing code to run out of available stack memory, causing *named* to terminate unexpectedly. This has been fixed. (CVE-2023-3341)  
ISC would like to thank Eric Sesterhenn from X41 D-Sec GmbH for bringing this vulnerability to our attention. [GL #4152]
- A flaw in the networking code handling DNS-over-TLS queries could cause *named* to terminate unexpectedly due to an assertion failure under significant DNS-over-TLS query load. This has been fixed. (CVE-2023-4236)  
ISC would like to thank Robert Story from USC/ISI Root Server Operations for bringing this vulnerability to our attention. [GL #4242]

### 14.33.2 Removed Features

- The *dnssec-must-be-secure* option has been deprecated and will be removed in a future release. [GL #4263]

### 14.33.3 Feature Changes

- If the *server* command is specified, *nsupdate* now honors the *nsupdate -v* option for SOA queries by sending both the UPDATE request and the initial query over TCP. [GL #1181]

### 14.33.4 Bug Fixes

- The value of the If-Modified-Since header in the statistics channel was not being correctly validated for its length, potentially allowing an authorized user to trigger a buffer overflow. Ensuring the statistics channel is configured correctly to grant access exclusively to authorized users is essential (see the *statistics-channels* block definition and usage section). [GL #4124]  
This issue was reported independently by Eric Sesterhenn of X41 D-Sec GmbH and Cameron Whitehead.
- The Content-Length header in the statistics channel was lacking proper bounds checking. A negative or excessively large value could potentially trigger an integer overflow and result in an assertion failure. [GL #4125]  
This issue was reported by Eric Sesterhenn of X41 D-Sec GmbH.
- Several memory leaks caused by not clearing the OpenSSL error stack were fixed. [GL #4159]  
This issue was reported by Eric Sesterhenn of X41 D-Sec GmbH.
- The introduction of *krb5-subdomain-self-rhs* and *ms-subdomain-self-rhs* UPDATE policies accidentally caused *named* to return SERVFAIL responses to deletion requests for non-existent PTR and SRV records. This has been fixed. [GL #4280]
- The *stale-refresh-time* feature was mistakenly disabled when the server cache was flushed by *rndc flush*. This has been fixed. [GL #4278]
- BIND's memory consumption has been improved by implementing dedicated jemalloc memory arenas for sending buffers. This optimization ensures that memory usage is more efficient and better manages the return of memory pages to the operating system. [GL #4038]

- Previously, partial writes in the TLS DNS code were not accounted for correctly, which could have led to DNS message corruption. This has been fixed. [GL #4255]

### 14.33.5 Known Issues

- There are no new known issues with this release. See *above* for a list of all known issues affecting this BIND 9 branch.

## 14.34 Notes for BIND 9.18.18

### 14.34.1 Feature Changes

- When a primary server for a zone responds to an SOA query, but the subsequent TCP connection required to transfer the zone is refused, that server is marked as temporarily unreachable. This now also happens if the TCP connection attempt times out, preventing too many zones from queuing up on an unreachable server and allowing the refresh process to move on to the next configured primary more quickly. [GL #4215]
- The *dialup* and *heartbeat-interval* options have been deprecated and will be removed in a future BIND 9 release. [GL #3700]

### 14.34.2 Bug Fixes

- Processing already-queued queries received over TCP could cause an assertion failure, when the server was reconfigured at the same time or the cache was being flushed. This has been fixed. [GL #4200]
- Setting *dnssec-policy* to *insecure* prevented zones containing resource records with a TTL value larger than 86400 seconds (1 day) from being loaded. This has been fixed by ignoring the TTL values in the zone and using a value of 604800 seconds (1 week) as the maximum zone TTL in key rollover timing calculations. [GL #4032]

### 14.34.3 Known Issues

- There are no new known issues with this release. See *above* for a list of all known issues affecting this BIND 9 branch.

## 14.35 Notes for BIND 9.18.17

### 14.35.1 Feature Changes

- If a response from an authoritative server has its RCODE set to FORMERR and contains an echoed EDNS COOKIE option that was present in the query, *named* now retries sending the query to the same server without an EDNS COOKIE option. [GL #4049]
- The *relaxed* QNAME minimization mode now uses NS records. This reduces the number of queries *named* makes when resolving, as it allows the non-existence of NS RRsets at non-referral nodes to be cached in addition to the normally cached referrals. [GL #3325]

### 14.35.2 Bug Fixes

- The ability to read HMAC-MD5 key files, which was accidentally lost in BIND 9.18.8, has been restored. [GL #3668] [GL #4154]
- Several minor stability issues with the catalog zone implementation have been fixed. [GL #4132] [GL #4136] [GL #4171]

### 14.35.3 Known Issues

- There are no new known issues with this release. See *above* for a list of all known issues affecting this BIND 9 branch.

## 14.36 Notes for BIND 9.18.16

### 14.36.1 Security Fixes

- The overmem cleaning process has been improved, to prevent the cache from significantly exceeding the configured `max-cache-size` limit. (CVE-2023-2828) [GL #4055]

ISC would like to thank Shoham Danino from Reichman University, Anat Bremler-Barr from Tel-Aviv University, Yehuda Afek from Tel-Aviv University, and Yuval Shavitt from Tel-Aviv University for bringing this vulnerability to our attention. [GL #4055]

- A query that prioritizes stale data over lookup triggers a fetch to refresh the stale data in cache. If the fetch is aborted for exceeding the recursion quota, it was possible for `named` to enter an infinite callback loop and crash due to stack overflow. This has been fixed. (CVE-2023-2911) [GL #4089]

### 14.36.2 New Features

- The system test suite can now be executed with `pytest` (along with `pytest-xdist` for parallel execution). [GL #3978]

### 14.36.3 Removed Features

- TKEY mode 2 (Diffie-Hellman Exchanged Keying) is now deprecated, and will be removed in a future release. A warning will be logged when the `tkey-dhkey` option is used in `named.conf`. [GL #3905]

### 14.36.4 Bug Fixes

- BIND could get stuck on reconfiguration when a `listen-on` statement for HTTP is removed from the configuration. That has been fixed. [GL #4071]
- Previously, it was possible for a delegation from cache to be returned to the client after the `stale-answer-client-timeout` duration. This has been fixed. [GL #3950]
- BIND could allocate too big buffers when sending data via stream-based DNS transports, leading to increased memory usage. This has been fixed. [GL #4038]
- When the `stale-answer-enable` option was enabled and the `stale-answer-client-timeout` option was enabled and larger than 0, `named` previously allocated two slots from the `clients-per-query` limit for each client and failed to gradually auto-tune its value, as configured. This has been fixed. [GL #4074]

### 14.36.5 Known Issues

- There are no new known issues with this release. See *above* for a list of all known issues affecting this BIND 9 branch.

## 14.37 Notes for BIND 9.18.15

### 14.37.1 Bug Fixes

- The `max-transfer-time-in` and `max-transfer-idle-in` statements have not had any effect since the BIND 9 networking stack was refactored in version 9.16. The missing functionality has been re-implemented and incoming zone transfers now time out properly when not progressing. [GL #4004]

- The read timeout in `rndc` is now 60 seconds, matching the behavior in BIND 9.16 and earlier. It had previously been lowered to 30 seconds by mistake. [GL #4046]
- When the `ISC_R_INVALIDPROTO` (`ENOPROTOOPT`, `EPROTONOSUPPORT`) error code is returned by `libuv`, it is now treated as a network failure: the server for which that error code is returned gets marked as broken and is not contacted again during a given resolution process. [GL #4005]
- When removing delegations from an opt-out range, empty-non-terminal NSEC3 records generated by those delegations were not cleaned up. This has been fixed. [GL #4027]
- Log file rotation code did not clean up older versions of log files when the logging `channel` had an absolute path configured as a `file` destination. This has been fixed. [GL #3991]

### 14.37.2 Known Issues

- Sending NOTIFY messages silently fails when the source port specified in the `notify-source` statement is already in use. This can happen e.g. when multiple servers are configured as NOTIFY targets for a zone and some of them are unresponsive. This issue can be worked around by not specifying the source port for NOTIFY messages in the `notify-source` statement; note that source port configuration is already `deprecated` and will be removed altogether in a future release. [GL #4002]
- See *above* for a list of all known issues affecting this BIND 9 branch.

## 14.38 Notes for BIND 9.18.14

### 14.38.1 Removed Features

- Zone type `delegation-only`, and the `delegation-only` and `root-delegation-only` statements, have been deprecated. A warning is now logged when they are used.

These statements were created to address the SiteFinder controversy, in which certain top-level domains redirected misspelled queries to other sites instead of returning NXDOMAIN responses. Since top-level domains are now DNSSEC-signed, and DNSSEC validation is active by default, the statements are no longer needed. [GL #3953]

### 14.38.2 Bug Fixes

- Several bugs which could cause `named` to crash during catalog zone processing have been fixed. [GL #3955] [GL #3968] [GL #3997]
- Previously, downloading large zones over TLS (XoT) from a primary could hang the transfer on the secondary, especially when the connection was unstable. This has been fixed. [GL #3867]
- Performance of DNSSEC validation in zones with many DNSKEY records has been improved. [GL #3981]

### 14.38.3 Known Issues

- There are no new known issues with this release. See *above* for a list of all known issues affecting this BIND 9 branch.

## 14.39 Notes for BIND 9.18.13

### 14.39.1 New Features

- RPZ updates are now run on specialized "offload" threads to reduce the amount of time they block query processing on the main networking threads. This increases the responsiveness of `named` when RPZ updates are being applied after an RPZ zone has been successfully transferred. [GL #3190]

### 14.39.2 Feature Changes

- Catalog zone updates are now run on specialized "offload" threads to reduce the amount of time they block query processing on the main networking threads. This increases the responsiveness of *named* when catalog zone updates are being applied after a catalog zone has been successfully transferred. [GL #3881]
- libuv support for receiving multiple UDP messages in a single `recvmsg()` system call has been tweaked several times between libuv versions 1.35.0 and 1.40.0; the current recommended libuv version is 1.40.0 or higher. New rules are now in effect for running with a different version of libuv than the one used at compilation time. These rules may trigger a fatal error at startup:
  - Building against or running with libuv versions 1.35.0 and 1.36.0 is now a fatal error.
  - Running with libuv version higher than 1.34.2 is now a fatal error when *named* is built against libuv version 1.34.2 or lower.
  - Running with libuv version higher than 1.39.0 is now a fatal error when *named* is built against libuv version 1.37.0, 1.38.0, 1.38.1, or 1.39.0.

This prevents the use of libuv versions that may trigger an assertion failure when receiving multiple UDP messages in a single system call. [GL #3840]

### 14.39.3 Bug Fixes

- *named* could crash with an assertion failure when adding a new zone into the configuration file for a name which was already configured as a member zone for a catalog zone. This has been fixed. [GL #3911]
- When *named* starts up, it sends a query for the DNSSEC key for each configured trust anchor to determine whether the key has changed. In some unusual cases, the query might depend on a zone for which the server is itself authoritative, and would have failed if it were sent before the zone was fully loaded. This has now been fixed by delaying the key queries until all zones have finished loading. [GL #3673]

### 14.39.4 Known Issues

- There are no new known issues with this release. See *above* for a list of all known issues affecting this BIND 9 branch.

## 14.40 Notes for BIND 9.18.12

### 14.40.1 Removed Features

- Specifying a `port` when configuring source addresses (i.e., as an argument to *query-source*, *query-source-v6*, *transfer-source*, *transfer-source-v6*, *notify-source*, *notify-source-v6*, *parental-source*, or *parental-source-v6*, or in the `source` or `source-v6` arguments to *primaries*, *parental-agents*, *also-notify*, or *catalog-zones*) has been deprecated. In addition, the *use-v4-udp-ports*, *use-v6-udp-ports*, *avoid-v4-udp-ports*, and *avoid-v6-udp-ports* options have also been deprecated.

Warnings are now logged when any of these options are encountered in `named.conf`. In a future release, they will be made nonfunctional. [GL #3781]

### 14.40.2 Bug Fixes

- A constant stream of zone additions and deletions via `rndc reconfig` could cause increased memory consumption due to delayed cleaning of view memory. This has been fixed. [GL #3801]
- The speed of the message digest algorithms (MD5, SHA-1, SHA-2), and of NSEC3 hashing, has been improved. [GL #3795]

- Pointing *parental-agents* to a resolver did not work because the RD bit was not set on DS requests. This has been fixed. [GL #3783]
- Building BIND 9 failed when the `--enable-dnsrps` switch for `./configure` was used. This has been fixed. [GL #3827]

### 14.40.3 Known Issues

- There are no new known issues with this release. See *above* for a list of all known issues affecting this BIND 9 branch.

## 14.41 Notes for BIND 9.18.11

### 14.41.1 Security Fixes

- An UPDATE message flood could cause *named* to exhaust all available memory. This flaw was addressed by adding a new *update-quota* option that controls the maximum number of outstanding DNS UPDATE messages that *named* can hold in a queue at any given time (default: 100). (CVE-2022-3094)

ISC would like to thank Rob Schulhof from Infoblox for bringing this vulnerability to our attention. [GL #3523]

- *named* could crash with an assertion failure when an RRSIG query was received and *stale-answer-client-timeout* was set to a non-zero value. This has been fixed. (CVE-2022-3736)

ISC would like to thank Borja Marcos from Sarenet (with assistance by Iratxe Niño from Fundación Sarenet) for bringing this vulnerability to our attention. [GL #3622]

- *named* running as a resolver with the *stale-answer-client-timeout* option set to any value greater than 0 could crash with an assertion failure, when the *recursive-clients* soft quota was reached. This has been fixed. (CVE-2022-3924)

ISC would like to thank Maksym Odintsev from AWS for bringing this vulnerability to our attention. [GL #3619]

### 14.41.2 New Features

- The new *update-quota* option can be used to control the number of simultaneous DNS UPDATE messages that can be processed to update an authoritative zone on a primary server, or forwarded to the primary server by a secondary server. The default is 100. A new statistics counter has also been added to record events when this quota is exceeded, and the version numbers for the XML and JSON statistics schemas have been updated. [GL #3523]

### 14.41.3 Removed Features

- The Differentiated Services Code Point (DSCP) feature in BIND has been non-operational since the new Network Manager was introduced in BIND 9.16. It is now marked as obsolete, and vestigial code implementing it has been removed. Configuring DSCP values in `named.conf` now causes a warning to be logged. [GL #3773]

### 14.41.4 Feature Changes

- The catalog zone implementation has been optimized to work with hundreds of thousands of member zones. [GL #3212] [GL #3744]

### 14.41.5 Bug Fixes

- A rare assertion failure was fixed in outgoing TCP DNS connection handling. [GL #3178] [GL #3636]
- Large zone transfers over TLS (XoT) could fail. This has been fixed. [GL #3772]

- In addition to a previously fixed bug, another similar issue was discovered where quotas could be erroneously reached for servers, including any configured forwarders, resulting in SERVFAIL answers being sent to clients. This has been fixed. [GL #3752]
- In certain query resolution scenarios (e.g. when following CNAME records), *named* configured to answer from stale cache could return a SERVFAIL response despite a usable, non-stale answer being present in the cache. This has been fixed. [GL #3678]
- When an outgoing request timed out, *named* would retry up to three times with the same server instead of trying the next available name server. This has been fixed. [GL #3637]
- Recently used ADB names and ADB entries (IP addresses) could get cleaned when ADB was under memory pressure. To mitigate this, only actual ADB names and ADB entries are now counted (excluding internal memory structures used for "housekeeping") and recently used (<= 10 seconds) ADB names and entries are excluded from the overmem memory cleaner. [GL #3739]
- The "Prohibited" Extended DNS Error was inadvertently set in some NOERROR responses. This has been fixed. [GL #3743]
- Previously, TLS session resumption could have led to handshake failures when client certificates were used for authentication (Mutual TLS). This has been fixed. [GL #3725]

### 14.41.6 Known Issues

- There are no new known issues with this release. See *above* for a list of all known issues affecting this BIND 9 branch.

## 14.42 Notes for BIND 9.18.10

### 14.42.1 Feature Changes

- To reduce unnecessary memory consumption in the cache, NXDOMAIN records are no longer retained past the normal negative cache TTL, even if *stale-cache-enable* is set to *yes*. [GL #3386]
- The *auto-dnssec* option has been deprecated and will be removed in a future BIND 9.19.x release. Please migrate to *dnssec-policy*. [GL #3667]
- The *coresize*, *datasize*, *files*, and *stacksize* options have been deprecated. The limits these options set should be enforced externally, either by manual configuration (e.g. using *ulimit*) or via the process supervisor (e.g. *systemd*). [GL #3676]
- Setting alternate local addresses for inbound zone transfers has been deprecated. The relevant options (*alt-transfer-source*, *alt-transfer-source-v6*, and *use-alt-transfer-source*) will be removed in a future BIND 9.19.x release. [GL #3694]
- The number of HTTP headers allowed in requests sent to *named*'s statistics channel has been increased from 10 to 100, to accommodate some browsers that send more than 10 headers by default. [GL #3670]

### 14.42.2 Bug Fixes

- *named* could crash due to an assertion failure when an HTTP connection to the statistics channel was closed prematurely (due to a connection error, shutdown, etc.). This has been fixed. [GL #3693]
- When a catalog zone was removed from the configuration, in some cases a dangling pointer could cause the *named* process to crash. This has been fixed. [GL #3683]
- When a zone was deleted from a server, a key management object related to that zone was inadvertently kept in memory and only released upon shutdown. This could lead to constantly increasing memory use on servers with a high rate of changes affecting the set of zones being served. This has been fixed. [GL #3727]

- TLS configuration for primary servers was not applied for zones that were members of a catalog zone. This has been fixed. [GL #3638]
- In certain cases, *named* waited for the resolution of outstanding recursive queries to finish before shutting down. This was unintended and has been fixed. [GL #3183]
- *host* and *nslookup* command-line options setting the custom TCP/UDP port to use were ignored for ANY queries (which are sent over TCP). This has been fixed. [GL #3721]
- The zone `<name>/<class>: final reference detached` log message was moved from the INFO log level to the DEBUG(1) log level to prevent the *named-checkzone* tool from superfluously logging this message in non-debug mode. [GL #3707]

### 14.42.3 Known Issues

- There are no new known issues with this release. See *above* for a list of all known issues affecting this BIND 9 branch.

## 14.43 Notes for BIND 9.18.9

### 14.43.1 Bug Fixes

- A crash was fixed that happened when a *dnssec-policy* zone that used NSEC3 was reconfigured to enable *inline-signing*. [GL #3591]
- In certain resolution scenarios, quotas could be erroneously reached for servers, including any configured forwarders, resulting in SERVFAIL answers being sent to clients. This has been fixed. [GL #3598]
- *rpz-ip* rules in *response-policy* zones could be ineffective in some cases if a query had the CD (Checking Disabled) bit set to 1. This has been fixed. [GL #3247]
- Previously, if Internet connectivity issues were experienced during the initial startup of *named*, a BIND resolver with *dnssec-validation* set to *auto* could enter into a state where it would not recover without stopping *named*, manually deleting the *managed-keys.bind* and *managed-keys.bind.jnl* files, and starting *named* again. This has been fixed. [GL #2895]
- The statistics counter representing the current number of clients awaiting recursive resolution results (*RecursClients*) could overflow in certain resolution scenarios. This has been fixed. [GL #3584]
- Previously, the port in remote servers such as in *primaries* and *parental-agents* could be wrongly configured because of an inheritance bug. This has been fixed. [GL #3627]
- Previously, BIND failed to start on Solaris-based systems with hundreds of CPUs. This has been fixed. [GL #3563]
- When a DNS resource record's TTL value was equal to the resolver's configured *prefetch* "eligibility" value, the record was erroneously not treated as eligible for prefetching. This has been fixed. [GL #3603]

### 14.43.2 Known Issues

- There are no new known issues with this release. See *above* for a list of all known issues affecting this BIND 9 branch.

## 14.44 Notes for BIND 9.18.8

### 14.44.1 Known Issues

- Upgrading from BIND 9.16.32, 9.18.6, or any older version may require a manual configuration change. The following configurations are affected:
  - `type primary` zones configured with `dnssec-policy` but without either `allow-update` or `update-policy`,
  - `type secondary` zones configured with `dnssec-policy`.In these cases please add `inline-signing yes;` to the individual zone configuration(s). Without applying this change, `named` will fail to start. For more details, see <https://kb.isc.org/docs/dnssec-policy-requires-dynamic-dns-or-inline-signing>
- BIND 9.18 does not support dynamic update forwarding (see `allow-update-forwarding`) in conjunction with zone transfers over TLS (XoT). [GL #3512]
- See *above* for a list of all known issues affecting this BIND 9 branch.

### 14.44.2 New Features

- Support for parsing and validating the `dohpath` service parameter in SVCB records was added. [GL #3544]
- `named` now logs the supported cryptographic algorithms during startup and in the output of `named -V`. [GL #3541]
- The `recursion not available` and `query (cache) '...' denied` log messages were extended to include the name of the ACL that caused a given query to be denied. [GL #3587]

### 14.44.3 Feature Changes

- The ability to use PKCS#11 via `engine_pkcs11` has been restored, by using only deprecated APIs in OpenSSL 3.0.0. BIND 9 needs to be compiled with `-DOPENSSL_API_COMPAT=10100` specified in the CFLAGS environment variable at compile time. [GL #3578]

### 14.44.4 Bug Fixes

- An assertion failure was fixed in `named` that was caused by aborting the statistics channel connection while sending statistics data to the client. [GL #3542]
- Changing just the TSIG key names for primaries in catalog zones' member zones was not effective. This has been fixed. [GL #3557]

## 14.45 Notes for BIND 9.18.7

### 14.45.1 Security Fixes

- Previously, there was no limit to the number of database lookups performed while processing large delegations, which could be abused to severely impact the performance of `named` running as a recursive resolver. This has been fixed. (CVE-2022-2795)  
  
ISC would like to thank Yehuda Afek from Tel-Aviv University and Anat Bremler-Barr & Shani Stajnsrod from Reichman University for bringing this vulnerability to our attention. [GL #3394]
- When an HTTP connection was reused to request statistics from the stats channel, the content length of successive responses could grow in size past the end of the allocated buffer. This has been fixed. (CVE-2022-2881) [GL #3493]

- Memory leaks in code handling Diffie-Hellman (DH) keys were fixed that could be externally triggered, when using TKEY records in DH mode with OpenSSL 3.0.0 and later versions. (CVE-2022-2906) [GL #3491]
- `named` running as a resolver with the `stale-answer-client-timeout` option set to 0 could crash with an assertion failure, when there was a stale CNAME in the cache for the incoming query. This has been fixed. (CVE-2022-3080) [GL #3517]
- Memory leaks were fixed that could be externally triggered in the DNSSEC verification code for the EdDSA algorithm. (CVE-2022-38178) [GL #3487]

## 14.45.2 Feature Changes

- Response Rate Limiting (RRL) code now treats all QNAMEs that are subject to wildcard processing within a given zone as the same name, to prevent circumventing the limits enforced by RRL. [GL #3459]
- Zones using `dnssec-policy` now require dynamic DNS or `inline-signing` to be configured explicitly. [GL #3381]
- When reconfiguring `dnssec-policy` from using NSEC with an NSEC-only DNSKEY algorithm (e.g. RSASHA1) to a policy that uses NSEC3, BIND 9 no longer fails to sign the zone; instead, it keeps using NSEC until the offending DNSKEY records have been removed from the zone, then switches to using NSEC3. [GL #3486]
- A backward-compatible approach was implemented for encoding internationalized domain names (IDN) in `dig` and converting the domain to IDNA2008 form; if that fails, BIND tries an IDNA2003 conversion. [GL #3485]

## 14.45.3 Bug Fixes

- A serve-stale bug was fixed, where BIND would try to return stale data from cache for lookups that received duplicate queries or queries that would be dropped. This bug resulted in premature SERVFAIL responses, and has now been resolved. [GL #2982]

## 14.45.4 Known Issues

- There are no new known issues with this release. See *above* for a list of all known issues affecting this BIND 9 branch.

## 14.46 Notes for BIND 9.18.6

### 14.46.1 Feature Changes

- The DNSSEC algorithms RSASHA1 and NSEC3RSASHA1 are now automatically disabled on systems where they are disallowed by the security policy (e.g. Red Hat Enterprise Linux 9). Primary zones using those algorithms need to be migrated to new algorithms prior to running on these systems, as graceful migration to different DNSSEC algorithms is not possible when RSASHA1 is disallowed by the operating system. [GL #3469]
- Log messages related to fetch limiting have been improved to provide more complete information. Specifically, the final counts of allowed and spilled fetches are now logged before the counter object is destroyed. [GL #3461]

### 14.46.2 Bug Fixes

- When running as a validating resolver forwarding all queries to another resolver, `named` could crash with an assertion failure. These crashes occurred when the configured forwarder sent a broken DS response and `named` failed its attempts to find a proper one instead. This has been fixed. [GL #3439]
- Non-dynamic zones that inherit `dnssec-policy` from the `view` or `options` blocks were not marked as inline-signed and therefore never scheduled to be re-signed. This has been fixed. [GL #3438]

- The old `max-zone-ttl` zone option was meant to be superseded by the `max-zone-ttl` option in `dnssec-policy`; however, the latter option was not fully effective. This has been corrected: zones no longer load if they contain TTLs greater than the limit configured in `dnssec-policy`. For zones with both the old `max-zone-ttl` option and `dnssec-policy` configured, the old option is ignored, and a warning is generated. [GL #2918]
- `rndc dumpdb -expired` was fixed to include expired RRsets, even if `stale-cache-enable` is set to `no` and the cache-cleaning time window has passed. [GL #3462]

### 14.46.3 Known Issues

- There are no new known issues with this release. See *above* for a list of all known issues affecting this BIND 9 branch.

## 14.47 Notes for BIND 9.18.5

### 14.47.1 Feature Changes

- The `dnssec-signzone -H` default value has been changed to 0 additional NSEC3 iterations. This change aligns the `dnssec-signzone` default with the default used by the `dnssec-policy` feature. At the same time, documentation about NSEC3 has been aligned with the *Best Current Practice*. [GL #3395]

### 14.47.2 Bug Fixes

- An assertion failure caused by a TCP connection closing between a connect (or accept) and a read from a socket has been fixed. [GL #3400]
- When grafting non-delegated namespace onto delegated namespace, `synth-from-dnssec` could incorrectly synthesize non-existence of records within the non-delegated namespace using NSEC records from higher zones. [GL #3402]
- Previously, `named` immediately returned a SERVFAIL response to the client when it received a FORMERR response from an authoritative server during recursive resolution. This has been fixed: `named` acting as a resolver now attempts to contact other authoritative servers for a given domain when it receives a FORMERR response from one of them. [GL #3152]
- Previously, `rndc reconfig` did not pick up changes to `endpoints` statements in `http` blocks. This has been fixed. [GL #3415]
- It was possible for a catalog zone consumer to process a catalog zone member zone when there was a configured pre-existing forward-only forward zone with the same name. This has been fixed. [GL #2506]

### 14.47.3 Known Issues

- There are no new known issues with this release. See *above* for a list of all known issues affecting this BIND 9 branch.

## 14.48 Notes for BIND 9.18.4

### 14.48.1 Feature Changes

- New `dnssec-policy` configuration checks have been added to detect unusual policies, such as missing KSK and/or ZSK and too-short key lifetimes and re-sign periods. [GL #1611]

## 14.48.2 Bug Fixes

- The `fetches-per-server` quota is designed to adjust itself downward automatically when an authoritative server times out too frequently. Due to a coding error, that adjustment was applied incorrectly, so that the quota for a congested server was always set to 1. This has been fixed. [GL #3327]
- DNSSEC-signed catalog zones were not being processed correctly. This has been fixed. [GL #3380]
- Key files were updated every time the `dnssec-policy` key manager ran, whether the metadata had changed or not. `named` now checks whether changes were applied before writing out the key files. [GL #3302]

## 14.48.3 Known Issues

- There are no new known issues with this release. See *above* for a list of all known issues affecting this BIND 9 branch.

## 14.49 Notes for BIND 9.18.3

### 14.49.1 Security Fixes

- Previously, TLS socket objects could be destroyed prematurely, which triggered assertion failures in `named` instances serving DNS-over-HTTPS (DoH) clients. This has been fixed.

ISC would like to thank Thomas Amgarten from arcade solutions ag for bringing this vulnerability to our attention. (CVE-2022-1183) [GL #3216]

### 14.49.2 Known Issues

- According to [RFC 8310](#), Section 8.1, the `Subject` field MUST NOT be inspected when verifying a remote certificate while establishing a DNS-over-TLS connection. Only `subjectAltName` must be checked instead. Unfortunately, some quite old versions of cryptographic libraries might lack the ability to ignore the `Subject` field. This should have minimal production-use consequences, as most of the production-ready certificates issued by certificate authorities will have `subjectAltName` set. In such cases, the `Subject` field is ignored. Only old platforms are affected by this, e.g. those supplied with OpenSSL versions older than 1.1.1. [GL #3163]
- See *above* for a list of all known issues affecting this BIND 9 branch.

### 14.49.3 New Features

- Catalog Zones schema version 2, as described in the "DNS Catalog Zones" IETF draft version 5 document, is now supported by `named`. All of the previously supported BIND-specific catalog zone custom properties (`primaries`, `allow-query`, and `allow-transfer`), as well as the new Change of Ownership (`coo`) property, are now implemented. Schema version 1 is still supported, with some additional validation rules applied from schema version 2: for example, the `version` property is mandatory, and a member zone PTR RRset must not contain more than one record. In the event of a validation error, a corresponding error message is logged to help with diagnosing the problem. [GL #3221] [GL #3222] [GL #3223] [GL #3224] [GL #3225]
- Support DNS Extended Errors ([RFC 8914](#)) `Stale Answer` and `Stale NXDOMAIN Answer` when stale answers are returned from cache. [GL #2267]
- Add support for remote TLS certificate verification, both to `named` and `dig`, making it possible to implement Strict and Mutual TLS authentication, as described in [RFC 9103](#), Section 9.3. [GL #3163]

### 14.49.4 Bug Fixes

- Previously, CDS and CDNSKEY DELETE records were removed from the zone when configured with the `auto-dnssec maintain;` option. This has been fixed. [GL #2931]

## 14.50 Notes for BIND 9.18.2

### 14.50.1 New Features

- Add a new configuration option `reuseport` to disable load balancing on sockets in situations where processing of Response Policy Zones (RPZ), Catalog Zones, or large zone transfers can cause service disruptions. See the BIND 9 ARM for more detail. [GL #3249]

### 14.50.2 Bug Fixes

- Previously, zone maintenance DNS queries retried forever if the destination server was unreachable. These queries included outgoing NOTIFY messages, refresh SOA queries, parental DS checks, and stub zone NS queries. For example, if a zone had any nameservers with IPv6 addresses and a secondary server without IPv6 connectivity, that server would keep trying to send a growing amount of NOTIFY traffic over IPv6. This futile traffic was not logged. This excessive retry behavior has been fixed. [GL #3242]
- A number of crashes and hangs which could be triggered in `dig` were identified and addressed. [GL #3020] [GL #3128] [GL #3145] [GL #3184] [GL #3205] [GL #3244] [GL #3248]
- Invalid `dnssec-policy` definitions, where the defined keys did not cover both KSK and ZSK roles for a given algorithm, were being accepted. These are now checked, and the `dnssec-policy` is rejected if both roles are not present for all algorithms in use. [GL #3142]
- Handling of TCP write timeouts has been improved to track the timeout for each TCP write separately, leading to a faster connection teardown in case the other party is not reading the data. [GL #3200]

### 14.50.3 Known Issues

- There are no new known issues with this release. See *above* for a list of all known issues affecting this BIND 9 branch.

## 14.51 Notes for BIND 9.18.1

### 14.51.1 Security Fixes

- The rules for acceptance of records into the cache have been tightened to prevent the possibility of poisoning if forwarders send records outside the configured bailiwick. (CVE-2021-25220)

ISC would like to thank Xiang Li, Baojun Liu, and Chaoyi Lu from Network and Information Security Lab, Tsinghua University, and Changgen Zou from Qi An Xin Group Corp. for bringing this vulnerability to our attention. [GL #2950]

- TCP connections with `keep-response-order` enabled could leave the TCP sockets in the `CLOSE_WAIT` state when the client did not properly shut down the connection. (CVE-2022-0396) [GL #3112]
- Lookups involving a DNAME could trigger an assertion failure when `synth-from-dnssec` was enabled (which is the default). (CVE-2022-0635)

ISC would like to thank Vincent Levigneron from AFNIC for bringing this vulnerability to our attention. [GL #3158]

- When chasing DS records, a timed-out or artificially delayed fetch could cause `named` to crash while resuming a DS lookup. (CVE-2022-0667) [GL #3129]

### 14.51.2 Feature Changes

- The DLZ API has been updated: EDNS Client-Subnet (ECS) options sent by a client are now included in the client information sent to DLZ modules when processing queries. [GL #3082]
- DEBUG(1)-level messages were added when starting and ending the BIND 9 task-exclusive mode that stops normal DNS operation (e.g. for reconfiguration, interface scans, and other events that require exclusive access to a shared resource). [GL #3137]
- The limit on the number of simultaneously processed pipelined DNS queries received over TCP has been removed. Previously, it was capped at 23 queries processed at the same time. [GL #3141]

### 14.51.3 Bug Fixes

- A failed view configuration during a `named` reconfiguration procedure could cause inconsistencies in BIND internal structures, causing a crash or other unexpected errors. This has been fixed. [GL #3060]
- Previously, `named` logged a "quota reached" message when it hit its hard quota on the number of connections. That message was accidentally removed but has now been restored. [GL #3125]
- The `max-transfer-time-out` and `max-transfer-idle-out` options were not implemented when the BIND 9 networking stack was refactored in 9.16. The missing functionality has been re-implemented and outgoing zone transfers now time out properly when not progressing. [GL #1897]
- TCP connections could hang indefinitely if the other party did not read sent data, causing the TCP write buffers to fill. This has been fixed by adding a "write" timer. Connections that are hung while writing now time out after the `tcp-idle-timeout` period has elapsed. [GL #3132]
- Client TCP connections are now closed immediately when data received cannot be parsed as a valid DNS request. [GL #3149]
- The statistics counter representing the current number of clients awaiting recursive resolution results (`RecursClients`) could be miscalculated in certain resolution scenarios, potentially causing the value of the counter to drop below zero. This has been fixed. [GL #3147]
- An error in the processing of the `blackhole` ACL could cause some DNS requests sent by `named` to fail - for example, zone transfer requests and SOA refresh queries - if the destination address or prefix was specifically excluded from the ACL using `!`, or if the ACL was set to `none`. This has now been fixed. `blackhole` worked correctly when it was left unset, or if only positive-match elements were included. [GL #3157]
- Build errors were introduced in some DLZ modules due to an incomplete change in the previous release. This has been fixed. [GL #3111]

### 14.51.4 Known Issues

- There are no new known issues with this release. See *above* for a list of all known issues affecting this BIND 9 branch.

## 14.52 Notes for BIND 9.18.0

**Note**

This section only lists changes since BIND 9.16.25, the most recent release on the previous stable branch of BIND before the publication of BIND 9.18.0.

**14.52.1 Known Issues**

- `rndc` has been updated to use the new BIND network manager API. As the network manager currently has no support for UNIX-domain sockets, those cannot now be used with `rndc`. This will be addressed in a future release, either by restoring UNIX-domain socket support or by formally declaring them to be obsolete in the control channel. [GL #1759]
- See *above* for a list of all known issues affecting this BIND 9 branch.

**14.52.2 New Features**

- `named` now supports securing DNS traffic using Transport Layer Security (TLS). TLS is used by both DNS over TLS (DoT) and DNS over HTTPS (DoH).

`named` can use either a certificate provided by the user or an ephemeral certificate generated automatically upon startup. The `tls` block allows fine-grained control over TLS parameters. [GL #1840] [GL #2795] [GL #2796]

For debugging purposes, `named` logs TLS pre-master secrets when the `SSLKEYLOGFILE` environment variable is set. This enables troubleshooting of issues with encrypted traffic. [GL #2723]

- Support for DNS over TLS (DoT) has been added to `named`. Network interfaces for DoT are configured using the existing `listen-on` directive, while TLS parameters are configured using the new `tls` block. [GL #1840]

`named` supports **zone transfers over TLS** (XFR-over-TLS, XoT) for both incoming and outgoing zone transfers.

Incoming zone transfers over TLS are enabled by adding the `tls` keyword, followed by either the name of a previously configured `tls` block or the string `ephemeral`, to the addresses included in `primaries` lists. [GL #2392]

Similarly, the `allow-transfer` option was extended to accept additional `port` and `transport` parameters, to further restrict outgoing zone transfers to a particular port and/or DNS transport protocol. [GL #2776]

Note that zone transfers over TLS (XoT) require the `dot` Application-Layer Protocol Negotiation (ALPN) token to be selected in the TLS handshake, as required by **RFC 9103** section 7.1. This might cause issues with non-compliant XoT servers. [GL #2794]

The `dig` tool is now able to send DoT queries (`+tls` option). [GL #1840]

There is currently no support for forwarding DNS queries via DoT.

- Support for DNS over HTTPS (DoH) has been added to `named`. Both TLS-encrypted and unencrypted connections are supported (the latter may be used to offload encryption to other software). Network interfaces for DoH are configured using the existing `listen-on` directive, while TLS parameters are configured using the new `tls` block and HTTP parameters are configured using the new `http` block. [GL #1144] [GL #2472]

Server-side quotas on both the number of concurrent DoH connections and the number of active HTTP/2 streams per connection can be configured using the global `http-listener-clients` and `http-streams-per-connection` options, or the `listener-clients` and `streams-per-connection` parameters in an `http` block. [GL #2809]

The `dig` tool is now able to send DoH queries (`+https` option). [GL #1641]

There is currently no support for forwarding DNS queries via DoH.

DoH support can be disabled at compile time using a new build-time option, `--disable-doh`. This allows BIND 9 to be built without the `libnghttp2` library. [GL #2478]

- A new logging category, `rpz-passthru`, was added, which allows RPZ passthru actions to be logged into a separate channel. [GL #54]
- A new option, `nsdname-wait-recurse`, has been added to the `response-policy` clause in the configuration file. When set to `no`, RPZ NSDNAME rules are only applied if the authoritative nameservers for the query name have been looked up and are present in the cache. If this information is not present, the RPZ NSDNAME rules are ignored, but the information is looked up in the background and applied to subsequent queries. The default is `yes`, meaning that RPZ NSDNAME rules should always be applied, even if the information needs to be looked up first. [GL #1138]
- Support for HTTPS and SVCB record types now also includes ADDITIONAL section processing for these record types. [GL #1132]
- New configuration options, `tcp-receive-buffer`, `tcp-send-buffer`, `udp-receive-buffer`, and `udp-send-buffer`, have been added. These options allow the operator to fine-tune the receiving and sending buffers in the operating system. On busy servers, increasing the size of the receive buffers can prevent the server from dropping packets during short traffic spikes, and decreasing it can prevent the server from becoming clogged with queries that are too old and have already timed out. [GL #2313]
- New finer-grained `update-policy` rule types, `krb5-subdomain-self-rhs` and `ms-subdomain-self-rhs`, were added. These rule types restrict updates to SRV and PTR records so that their content can only match the machine name embedded in the Kerberos principal making the change. [GL #481]
- Per-type record count limits can now be specified in `update-policy` statements, to limit the number of records of a particular type that can be added to a domain name via dynamic update. [GL #1657]
- Support for OpenSSL 3.0 APIs was added. [GL #2843] [GL #3057]
- Extended DNS Error Code 18 - Prohibited (see RFC 8914 section 4.19) is now set if query access is denied to the specific client. [GL #1836]
- `ipv4only.arpa` is now served when DNS64 is configured. [GL #385]
- `dig` can now report the DNS64 prefixes in use (`+dns64prefix`). This is useful when the host on which `dig` is run is behind an IPv6-only link, using DNS64/NAT64 or 464XLAT for IPv4aaS (IPv4 as a Service). [GL #1154]
- `dig` output now includes the transport protocol used (UDP, TCP, TLS, HTTPS). [GL #1144] [GL #1816]
- `dig +qid=<num>` allows the user to specify a particular query ID for testing purposes. [GL #1851]

### 14.52.3 Removed Features

- Support for the `map` zone file format (`masterfile-format map;`) has been removed. Users relying on the `map` format are advised to convert their zones to the `raw` format with `named-compilezone` and change the configuration appropriately prior to upgrading BIND 9. [GL #2882]
- Old-style Dynamically Loadable Zones (DLZ) drivers that had to be enabled in `named` at build time have been removed. New-style DLZ modules should be used as a replacement. [GL #2814]
- Support for compiling and running BIND 9 natively on Windows has been completely removed. The last stable release branch that has working Windows support is BIND 9.16. [GL #2690]
- Native PKCS#11 support has been removed. [GL #2691]

When built against OpenSSL 1.x, BIND 9 now *uses engine\_pkcs11 for PKCS#11*. `engine_pkcs11` is an OpenSSL engine which is part of the [OpenSC](#) project.

As support for so-called "engines" was deprecated in OpenSSL 3.x, compiling BIND 9 against an OpenSSL 3.x build which does not retain support for deprecated APIs makes it impossible to use PKCS#11 in BIND 9. A replacement for `engine_pkcs11` which employs the new "provider" approach introduced in OpenSSL 3.x is in the making. [GL #2843]

- The utilities `dnssec-checkds`, `dnssec-coverage`, and `dnssec-keymgr` have been removed from the BIND distribution, as well as the `isc` Python package. DNSSEC features formerly provided by these utilities are now integrated into `named`. See the `dnssec-policy` configuration option for more details.

An archival version of the Python utilities has been moved to the repository <https://gitlab.isc.org/isc-projects/dnssec-keymgr/>. Please note these tools are no longer supported by ISC.

- Since the old socket manager API has been removed, "socketmgr" statistics are no longer reported by the `statistics-channels`. [GL #2926]
- The `glue-cache` option has been marked as deprecated. The glue cache *feature* still works and will be permanently *enabled* in a future release. [GL #2146]
- A number of non-working configuration options that had been marked as obsolete in previous releases have now been removed completely. Using any of the following options is now considered a configuration failure: `acache-cleaning-interval`, `acache-enable`, `additional-from-auth`, `additional-from-cache`, `allow-v6-synthesis`, `cleaning-interval`, `dnssec-enable`, `dnssec-lookaside`, `filter-aaaa`, `filter-aaaa-on-v4`, `filter-aaaa-on-v6`, `geoip-use-ecs`, `lwres`, `max-acache-size`, `nosit-udp-size`, `queryport-pool-ports`, `queryport-pool-updateinterval`, `request-sit`, `sit-secret`, `support-ixfr`, `use-queryport-pool`, `use-ixfr`. [GL #1086]
- The `dig` option `+unexpected` has been removed. [GL #2140]
- IPv6 sockets are now explicitly restricted to sending and receiving IPv6 packets only. As this breaks the `+mapped` option for `dig`, the option has been removed. [GL #3093]
- Disable and disallow static linking of BIND 9 binaries and libraries as BIND 9 modules require `dlopen()` support and static linking also prevents using security features like read-only relocations (RELRO) or address space layout randomization (ASLR) which are important for programs that interact with the network and process arbitrary user input. [GL #1933]
- The `--with-gperftools-profiler` configure option was removed. To use the `gperftools` profiler, the `HAVE_GPERFTOOLS_PROFILER` macro now needs to be manually set in `CFLAGS` and `-lprofiler` needs to be present in `LDFLAGS`. [GL #4045]

## 14.52.4 Feature Changes

- Aggressive Use of DNSSEC-Validated Cache (`synth-from-dnssec`, see [RFC 8198](#)) is now enabled by default again, after having been disabled in BIND 9.14.8. The implementation of this feature was reworked to achieve better efficiency and tuned to ignore certain types of broken NSEC records. Negative answer synthesis is currently only supported for zones using NSEC. [GL #1265]
- The default NSEC3 parameters for `dnssec-policy` were updated to no extra SHA-1 iterations and no salt (`NSEC3PARAM 1 0 0 -`). This change is in line with the [latest NSEC3 recommendations](#). [GL #2956]
- The default for `dnssec-dnskey-kskonly` was changed to `yes`. This means that DNSKEY, CDNSKEY, and CDS RRsets are now only signed with the KSK by default. The additional signatures prepared using the ZSK when the option is set to `no` add to the DNS response payload without offering added value. [GL #1316]
- `dnssec-cds` now only generates SHA-2 DS records by default and avoids copying deprecated SHA-1 records from a child zone to its delegation in the parent. If the child zone does not publish SHA-2 CDS records, `dnssec-cds` will generate them from the CDNSKEY records. The `-a algorithm` option now affects the process of generating DS digest records from both CDS and CDNSKEY records. Thanks to Tony Finch. [GL #2871]
- Previously, `named` accepted FORMERR responses both with and without an OPT record, as an indication that a given server did not support EDNS. To implement full compliance with [RFC 6891](#), only FORMERR responses without an OPT record are now accepted. This intentionally breaks communication with servers that do not support EDNS and that incorrectly echo back the query message with the RCODE field set to FORMERR and the QR bit set to 1. [GL #2249]

- The question section is now checked when processing AXFR, IXFR, and SOA replies while transferring a zone in. [GL #1683]
- DNS Flag Day 2020: the EDNS buffer size probing code, which made the resolver adjust the EDNS buffer size used for outgoing queries based on the successful query responses and timeouts observed, was removed. The resolver now always uses the EDNS buffer size set in `edns-udp-size` for all outgoing queries. [GL #2183]
- Keeping stale answers in cache (`stale-cache-enable`) has been disabled by default. [GL #1712]
- Overall memory use by `named` has been optimized and significantly reduced, especially for resolver workloads. [GL #2398] [GL #3048]
- Memory allocation is now based on the memory allocation API provided by the `jemalloc` library, on platforms where it is available. Use of this library is now recommended when building BIND 9; although it is optional, it is enabled by default. [GL #2433]
- Internal data structures maintained for each cache database are now grown incrementally when they need to be expanded. This helps maintain a steady response rate on a loaded resolver while these internal data structures are resized. [GL #2941]
- The interface handling code has been refactored to use fewer resources, which should lead to less memory fragmentation and better startup performance. [GL #2433]
- When reporting zone types in the statistics channel, the terms `primary` and `secondary` are now used instead of `master` and `slave`, respectively. [GL #1944]
- The `rndc nta -dump` and `rndc secroots` commands now both include `validate-except` entries when listing negative trust anchors. These are indicated by the keyword `permanent` in place of the expiry date. [GL #1532]
- The output of `rndc serve-stale status` has been clarified. It now explicitly reports whether retention of stale data in the cache is enabled (`stale-cache-enable`), and whether returning such data in responses is enabled (`stale-answer-enable`). [GL #2742]
- Previously, using `dig +bufsize=0` had the side effect of disabling EDNS, and there was no way to test the remote server's behavior when it had received a packet with EDNS0 buffer size set to 0. This is no longer the case; `dig +bufsize=0` now sends a DNS message with EDNS version 0 and buffer size set to 0. To disable EDNS, use `dig +noedns`. [GL #2054]
- BIND 9 binaries which are neither daemons nor administrative programs were moved to `$bindir`. Only `ddns-confgen`, `named`, `rndc`, `rndc-confgen`, and `tsig-confgen` were left in `$bindir`. [GL #1724]
- The BIND 9 build system has been changed to use a typical `autoconf+automake+libtool` stack. This should not make any difference for people building BIND 9 from release tarballs, but when building BIND 9 from the Git repository, `autoreconf -fi` needs to be run first. Extra attention is also needed when using non-standard configure options. [GL #4]

## 14.52.5 Bug Fixes

- Log files using `timestamp`-style suffixes were not always correctly removed when the number of files exceeded the limit set by `versions`. This has been fixed. [GL #828]

## 14.53 License

BIND 9 is open source software licensed under the terms of the Mozilla Public License, version 2.0 (see the `COPYING` file for the full text).

Those wishing to discuss license compliance may contact ISC at <https://www.isc.org/contact/>.

## **14.54 End of Life**

BIND 9.18 (Extended Support Version) will be supported until at least December, 2025. See <https://kb.isc.org/docs/aa-00896> for details of ISC's software support policy.

## **14.55 Thank You**

Thank you to everyone who assisted us in making this release possible.

## CHANGELOG

**Note**

The following list contains detailed information about BIND 9 development. Regular users should refer to *Release Notes* for changes relevant to them.

### 15.1 BIND 9.18.47

#### 15.1.1 Security Fixes

- [CVE-2026-1519] Fix unbounded NSEC3 iterations when validating referrals to unsigned delegations. [5ef459eaa9](#)

DNSSEC-signed zones may contain high iteration-count NSEC3 records, which prove that certain delegations are insecure. Previously, a validating resolver encountering such a delegation processed these iterations up to the number given, which could be a maximum of 65,535. This has been addressed by introducing a processing limit, set at 150. Now, if such an NSEC3 record is encountered, the delegation will be treated as insecure.

ISC would like to thank Samy Medjahed/Ap4sh for bringing this vulnerability to our attention. [\[GL #5708\]](#)

### 15.2 BIND 9.18.46

#### 15.2.1 Feature Changes

- Invalid NSEC3 can cause OOB read of the isdelegation() stack. [97fd0c56e48](#)

When `.next_length` is longer than `NSEC3_MAX_HASH_LENGTH`, it causes a harmless out-of-bound read of the `isdelegation()` stack. This has been fixed. [\[GL #5749\]](#) [\[GL !11595\]](#)

#### 15.2.2 Bug Fixes

- Clear serve-stale flags when following the CNAME chains. [7733cb4580e](#)

A stale answer could have been served in case of multiple upstream failures when following the CNAME chains. This has been fixed. [\[GL #5751\]](#) [\[GL !11584\]](#)

### 15.3 BIND 9.18.45

#### 15.3.1 Feature Changes

- Update requirements for system test suite. [37bd997a39](#)

Python 3.10 or newer is now required for running the system test suite. The required python packages and their version requirements are now tracked in *bin/tests/system/requirements.txt*.

Support for pytest 9.0.0 has been added its minimum supported version has been raised to 7.0.0. The minimum supported dnspython version has been raised to 2.3.0. [\[GL #5690\]](#) [\[GL #5614\]](#) [\[GL !11470\]](#)

## 15.3.2 Bug Fixes

- Use const pointer with strchr of const pointer. 2b10ee4f13

[\[GL #5694\]](#) [\[GL !11464\]](#)

- Fix brid and hhit implementation. e3caaa16f1

Fix bugs in BRID and HHIT implementation and enable the unit tests. [\[GL #5710\]](#) [\[GL !11493\]](#)

- DSYNC record incorrectly used two octets for the Scheme Field. 6fd748d1fc

When creating the *DSYNC* record from a structure, *uint16\_tobuffer* was used instead of *uint8\_tobuffer* when adding the scheme, causing a *DSYNC* record that was one octet too long. This has been fixed. [\[GL #5711\]](#) [\[GL !11484\]](#)

## 15.4 BIND 9.18.44

### 15.4.1 Security Fixes

- [CVE-2025-13878] Fix incorrect length checks for BRID and HHIT records. d556bde123

Malformed BRID and HHIT records could trigger an assertion failure. This has been fixed.

ISC would like to thank Vlatko Kosturjak from Marlink Cyber for bringing this vulnerability to our attention. [\[GL #5616\]](#)

### 15.4.2 Feature Changes

- Support compilation with cmocka 2.0.0+ 184df12da4

The *assert\_in\_range()* function was deprecated in favor of *assert\_int\_in\_range()* and *assert\_uint\_in\_range()*. Add compatibility shims for *cmocka*<2.0.0 and use the new functions. [\[GL #5699\]](#) [\[GL !11438\]](#)

### 15.4.3 Bug Fixes

- Allow glue in delegations with QTYPE=ANY. 21ad0222b7

When a query for type ANY triggered a delegation response, all additional data was omitted from the response, including mandatory glue. This has been corrected. [\[GL #5659\]](#) [\[GL !11368\]](#)

- Reconfigure NSEC3 opt-out zone to NSEC causes zone to be invalid. 53cfe984e3

A zone that is signed with NSEC3, opt-out enabled, and then reconfigured to use NSEC, causes the zone to be published with missing NSEC records. This has been fixed. [\[GL #5679\]](#) [\[GL !11402\]](#)

## 15.5 BIND 9.18.43

### 15.5.1 New Features

- Add spatch to detect implicit bool/int/result cast. cce6c2dd0c

Detection of implicit cast from a boolean into an int, or an *isc\_result\_t* into a boolean (either in an assignment or return position).

If such pattern is found, a warning comment is added into the code (and the CI will fail) so the error can be spotted and manually fixed. [\[GL !11238\]](#)

## 15.5.2 Bug Fixes

- AMTRELAY type 0 presentation format handling was wrong. [e5025baf93](#)

RFC 8777 specifies a placeholder value of "." for the gateway field when the gateway type is 0 (no gateway). This was not being checked for nor emitted when displaying the record. This has been corrected.

Instances of this record will need the placeholder period added to them when upgrading. [\[GL #5639\]](#) [\[GL !11256\]](#)

- Adding NSEC3 opt-out records could leave invalid records in chain. [335be0e079](#)

When creating an NSEC3 opt-out chain, a node in the chain could be removed too soon, causing the previous NSEC3 being unable to be found, resulting in invalid NSEC3 records to be left in the zone. This has been fixed. [\[GL #5671\]](#) [\[GL !11341\]](#)

- Standardize CHECK and RETERR macros. [83163f39d5](#)

previously, there were over 40 separate definitions of CHECK macros, of which most used "goto cleanup", and the rest "goto failure" or "goto out". there were another 10 definitions of RETERR, of which most were identical to CHECK, but some simply returned a result code instead of jumping to a cleanup label.

this has now been standardized throughout the code base: RETERR is for returning an error code in the case of an error, and CHECK is for jumping to a cleanup tag, which is now always called "cleanup". both macros are defined in `isc/util.h`. [\[GL !11080\]](#)

## 15.6 BIND 9.18.42

### 15.6.1 Bug Fixes

- Skip unsupported algorithms when looking for signing key. [2882dbfc803](#)

A mix of supported and unsupported DNSSEC algorithms in the same zone could have caused validation failures. Ignore the DNSSEC keys with unsupported algorithm when looking for the signing keys. [\[GL #5622\]](#) [\[GL !11211\]](#)

## 15.7 BIND 9.18.41

### 15.7.1 Security Fixes

- [\[CVE-2025-8677\]](#) DNSSEC validation fails if matching but invalid DNSKEY is found. [85d08e06831](#)

Previously, if a matching but cryptographically invalid key was encountered during DNSSEC validation, the key was skipped and not counted towards validation failures. `named` now treats such DNSSEC keys as hard failures and the DNSSEC validation fails immediately, instead of continuing with the next DNSKEYs in the RRset.

ISC would like to thank Zuyao Xu and Xiang Li from the All-in-One Security and Privacy Laboratory at Nankai University for bringing this vulnerability to our attention. [\[GL #5343\]](#)

- [\[CVE-2025-40778\]](#) Address various spoofing attacks. [4c99ba5a462](#)

Previously, several issues could be exploited to poison a DNS cache with spoofed records for zones which were not DNSSEC-signed or if the resolver was configured to not do DNSSEC validation. These issues were assigned CVE-2025-40778 and have now been fixed.

As an additional layer of protection, `named` no longer accepts DNAME records or extraneous NS records in the AUTHORITY section unless these are received via spoofing-resistant transport (TCP, UDP with DNS cookies, TSIG, or SIG(0)).

ISC would like to thank Yuxiao Wu, Yunyi Zhang, Baojun Liu, and Haixin Duan from Tsinghua University for bringing this vulnerability to our attention. [\[GL #5414\]](#)

- [\[CVE-2025-40780\]](#) Cache-poisoning due to weak pseudo-random number generator. [f74fb05265b](#)

It was discovered during research for an upcoming academic paper that a xoshiro128\*\* internal state can be recovered by an external 3rd party, allowing the prediction of UDP ports and DNS IDs in outgoing queries. This could lead to an attacker spoofing the DNS answers with great efficiency and poisoning the DNS cache.

The internal random generator has been changed to a cryptographically secure pseudo-random generator.

ISC would like to thank Prof. Amit Klein and Omer Ben Simhon from Hebrew University of Jerusalem for bringing this vulnerability to our attention. [\[GL #5484\]](#)

## 15.7.2 New Features

- Support for parsing HHIT and BRID records has been added. [d7d4e94d085](#)

[\[GL #5444\]](#) [\[GL !10933\]](#)

## 15.7.3 Removed Features

- Deprecate the "tkey-domain" statement. [e28c95c1160](#)

Mark the *tkey-domain* statement as deprecated since it is only used by code implementing TKEY Mode 2 (Diffie-Hellman), which was removed from newer BIND 9 branches. [\[GL #4204\]](#) [\[GL !10783\]](#)

- Deprecate the "tkey-gssapi-credential" statement. [2705307f818](#)

The *tkey-gssapi-keytab* statement allows GSS-TSIG to be set up in a simpler and more reliable way than using the *tkey-gssapi-credential* statement and setting environment variables (e.g. `KRB5_KTNAME`). Therefore, the *tkey-gssapi-credential* statement has been deprecated; *tkey-gssapi-keytab* should be used instead.

For configurations currently using a combination of both *tkey-gssapi-keytab* and *tkey-gssapi-credential*, the latter should be dropped and the keytab pointed to by *tkey-gssapi-keytab* should now only contain the credential previously specified by *tkey-gssapi-credential*. [\[GL #4204\]](#) [\[GL !10925\]](#)

## 15.7.4 Feature Changes

- Update clang-format style with options added in newer versions. [1bc0f245c79](#)

Add and apply `InsertBraces` statement to add missing curly braces around one-line statements and use `ControlStatementsExceptControlMacros` for `SpaceBeforeParens` to remove space between `foreach` macro and the brace, e.g. `FOREACH(x) {` becomes `FOREACH(x) {.` [\[GL !10865\]](#)

## 15.7.5 Bug Fixes

- Prevent spurious SERVFAILs for certain 0-TTL resource records. [f5a6a8be45f](#)

Under certain circumstances, BIND 9 can return SERVFAIL when updating existing entries in the cache with new NS, A, AAAA, or DS records with 0-TTL. [\[GL #5294\]](#) [\[GL !10899\]](#)

- Use `DNS_RDATACOMMON_INIT` to hide branch differences. [aef4682e4aa](#)

Initialization of the common members of `rdata` type structures varies across branches. Standardize it by using the `DNS_RDATACOMMON_INIT` macro for all types, so that new types are more likely to use it, and hence backport more cleanly. [\[GL #5467\]](#) [\[GL !10833\]](#)

- RPZ canonical warning displays zone entry incorrectly. [3e787e98930](#)

When an IPv6 rpz prefix entry is entered incorrectly the log message was just displaying the prefix rather than the full entry. This has been corrected. [\[GL #5491\]](#) [\[GL !10931\]](#)

- Missing DNSSEC information when CD bit is set in query. [990586f0496](#)

The RRSIGs for glue records were not being cached correctly for CD=1 queries. This has been fixed. [\[GL #5502\]](#) [\[GL !10957\]](#)

- Add and use `__attribute__((nonnull))` in `dnssec-signzone.c`. [48c30cfc08](#)

Clang 20 was spuriously warning about the possibility of passing a NULL file pointer to `fprintf()`, which uses the 'nonnull' attribute. To silence the warning, the functions calling `fprintf()` have been marked with the same attribute to assure that NULL can't be passed to them in the first place.

Close #5487 [\[GL !10914\]](#)

## 15.8 BIND 9.18.40

### Note

The BIND 9.18.40 release was withdrawn after the discovery of a regression in a security fix in it during pre-release testing.

## 15.9 BIND 9.18.39

### 15.9.1 New Features

- Support for parsing the DSYNC record has been added. [4eb5a0ba1c](#)

[\[GL #5440\]](#) [\[GL !10821\]](#)

### 15.9.2 Feature Changes

- Add deprecation warnings for RSASHA1, RSASHA1-NSEC3SHA1 and DS digest type 1. [1ea4164f71](#)

RSASHA1 and RSASHA1-NSEC-SHA1 DNSKEY algorithms have been deprecated by the IETF and should no longer be used for DNSSEC. DS digest type 1 (SHA1) has also been deprecated. Validators are now expected to treat these algorithms and digest as unknown, resulting in some zones being treated as insecure when they were previously treated as secure. Warnings have been added to named and tools when these algorithms and this digest are being used for signing.

Zones signed with RSASHA1 or RSASHA1-NSEC-SHA1 should be migrated to a different DNSKEY algorithm.

Zones with DS or CDS records with digest type 1 (SHA1) should be updated to use a different digest type (e.g. SHA256) and the digest type 1 records should be removed.

Related to #5358 [\[GL !10739\]](#)

### 15.9.3 Bug Fixes

- Fix a possible crash when adding a zone while recursing. [c8d4829223](#)

A query for a zone that was not yet loaded may yield an unexpected result such as a CNAME or DNAME, triggering an assertion failure. This has been fixed. [\[GL #5357\]](#) [\[GL !10719\]](#)

- Clean enough memory when adding new ADB names/entries under memory pressure. e2f539035d

The ADB memory cleaning is opportunistic even when we are under memory pressure (in the overmem condition). Split the opportunistic LRU cleaning and overmem cleaning and make the overmem cleaning always cleanup double of the newly allocated adbname/adbentry to ensure we never allocate more memory than the assigned limit. [GL !10708]

- Prevent spurious validation failures. 4d24dabc25

Under rare circumstances, validation could fail if multiple clients simultaneously iterated the same set of signatures. References #3014 [GL !10816]

- Rescan the interfaces again when reconfiguring the server. c9f05d750a

On FreeBSD, the server would not listen on the configured 'localhost' interfaces immediately, but only after the 'interface-interval' period has passed. After the fix for default interface-interval was merged in !10281, this means the server would listen on the localhost after 60 minutes.

Rescan the interfaces immediately after configuring the interface-interval value to start listening on the 'localhost' interface immediately. [GL !10758]

## 15.10 BIND 9.18.38

### 15.10.1 Security Fixes

- Fix an issue when some specific queries could remain unanswered with serve-stale enabled. 8ca561f6dce

When *named* was running with stale answers enabled and with the `stale-answer-client-timeout 0` configuration option, in certain situations it was possible that some queries could remain unanswered. This has been fixed. [GL #5383]

### 15.10.2 New Features

- Add support for the CO flag to dig. 9e897623701

Add support to display the CO (Compact Answers OK flag) when displaying messages.

Add support to set the CO flag when making queries in dig (+coflag). [GL #5319] [GL !10579]

### 15.10.3 Bug Fixes

- Fix the default interface-interval from 60s to 60m. 0be568f921d

When the interface-interval parser was changed from uint32 parser to duration parser, the default value stayed at plain number *60* which now means 60 seconds instead of 60 minutes. The documentation also incorrectly states that the value is in minutes. That has been fixed. [GL #5246] [GL !10680]

- Fix purge-keys bug when using views. df417186ef2

Previously, when a DNSSEC key was purged by one zone view, other zone views would return an error about missing key files. This has been fixed. [GL #5315] [GL !10599]

- Set name for all the isc\_mem contexts. 6c216c18d01

[GL !10499]

## 15.11 BIND 9.18.37

### 15.11.1 Bug Fixes

- Unify the `int32_t` vs `int_fast32_t` when working with atomic types. [8665d3be39c](#)

There's a mismatch between the atomic and non-atomic types that could potentially lead to a rwlock deadlock (after two billion  $2^{32}$ ) writes. Use `int_fast32_t` when loading the `atomic_int_fast32_t` types in the `isc_rwlock` unit. [\[GL #5280\]](#) [\[GL !10390\]](#)

## 15.12 BIND 9.18.36

### 15.12.1 New Features

- Implement `-T cookiealwaysvalid`. [efbd698a2d](#)

When `-T cookiealwaysvalid` is passed to `named`, DNS cookie checks for the incoming queries always pass, given they are structurally correct. [\[GL !10265\]](#)

### 15.12.2 Feature Changes

- Fix network manager issue when both success and timeout callbacks can be called for the same read request. [d4cc98a175](#)

This commit simplifies code flow in the `tls_cycle_input()` and makes the incoming data processing similar to that in TCP DNS. In particular, now we decipher all the the incoming data before making a single `isc__nm_process_sock_buffer()` call. Previously we would try to decipher data bit-by-bit before trying to process the deciphered bit via `isc__nm_process_sock_buffer()`. Doing like before made the code much less predictable, in particular in the areas like when reading is paused or resumed.

The newer approach also allowed us to get rid of some old kludges. [\[GL #5247\]](#) [\[GL !10294\]](#)

### 15.12.3 Bug Fixes

- Add missing locks when returning addresses. [ae573fd9dc](#)

Add missing locks in `dns_zone_getxfrsource4` et al. Addresses CID 468706, 468708, 468741, 468742, 468785, and 468778.

Cleanup `dns_zone_setxfrsource4` et al to now return void.

Remove double copies with `dns_zone_getprimaryaddr` and `dns_zone_getsourceaddr`. [\[GL #4933\]](#) [\[GL !10260\]](#)

- Stop caching lack of EDNS support. [84d0464646](#)

`named` could falsely learn that a server doesn't support EDNS when a spoofed response was received; that subsequently prevented DNSSEC lookups from being made. This has been fixed. [\[GL #3949\]](#) [\[GL #5066\]](#)

- Fix resolver statistics counters for timed out responses. [0e7419670e](#)

When query responses timed out, the resolver could incorrectly increase the regular responses counters, even if no response was received. This has been fixed. [\[GL #5193\]](#) [\[GL !10288\]](#)

- Validating ADB fetches could cause a crash in `import_rdataset()` [f24bacb190](#)

Previously, in some cases, the resolver could return `rdatasets` of type `CNAME` or `DNAME` without the result code being set to `DNS_R_CNAME` or `DNS_R_DNAME`. This could trigger an assertion failure in the ADB. The resolver error has been fixed. [\[GL #5201\]](#) [\[GL !10330\]](#)

- Don't enforce NOAUTH/NOCONF flags in DNSKEYs. [ddbea0b94b](#)

All DNSKEY keys are able to authenticate. The `DNS_KEYTYPE_NOAUTH` (and `DNS_KEYTYPE_NOCONF`) flags were defined for the KEY rdata type, and are not applicable to DNSKEY. Previously, however, because the DNSKEY implementation was built on top of KEY, the `_NOAUTH` flag prevented authentication in DNSKEYs as well. This has been corrected. [\[GL #5240\]](#) [\[GL !10316\]](#)

## 15.13 BIND 9.18.35

### 15.13.1 New Features

- Add digest methods for SIG and RRSIG. [7f4023fe7d](#)

ZONEMD digests RRSIG records and potentially digests SIG record. Add digests methods for both record types. [\[GL #5219\]](#) [\[GL !10219\]](#)

### 15.13.2 Bug Fixes

- Prevent a reference leak when using plugins. [8d0d08ec00](#)

The `NS_QUERY_DONE_BEGIN` and `NS_QUERY_DONE_SEND` plugin hooks could cause a reference leak if they returned `NS_HOOK_RETURN` without cleaning up the query context properly. [\[GL #2094\]](#) [\[GL !10171\]](#)

- Fix memory ordering issues with atomic operations in the quota.c module. [86f02349e5](#)

Change all the non-locked operations on `quota->used` and `quota->waiting` to "acq/rel" for inter-thread synchronization. Some loads are left as "relaxed", because they are under a locked mutex which also provides protection.

Also use relaxed memory ordering for `quota->max` and `quota->soft`, as done in the main branch; possible ordering issues for these variables are acceptable. [\[GL #5018\]](#) [\[GL !10203\]](#)

- Fix deferred validation of unsigned DS and DNSKEY records. [60a26ecd43](#)

When processing a query with the "checking disabled" bit set (CD=1), `named` stores the unvalidated result in the cache, marked "pending". When the same query is sent with CD=0, the cached data is validated, and either accepted as an answer, or ejected from the cache as invalid. This deferred validation was not attempted for DS and DNSKEY records if they had no cached signatures, causing spurious validation failures. We now complete the deferred validation in this scenario.

Also, if deferred validation fails, we now re-query the data to find out whether the zone has been corrected since the invalid data was cached. [\[GL #5066\]](#) [\[GL !10106\]](#)

- When recording an rr trace, use libtool. [42afefe031](#)

When a system test is run with the `USE_RR` environment variable set to 1, an `rr` trace is now correctly generated for each instance of `named`. [\[GL #5079\]](#) [\[GL !10208\]](#)

- Do not cache signatures for rejected data. [7e24b9f6ec](#)

The cache has been updated so that if new data is rejected - for example, because there was already existing data at a higher trust level - then its covering RRSIG will also be rejected. [\[GL #5132\]](#) [\[GL !10135\]](#)

- Fix a race issue in `dns_view_addzone()` [a946528023](#)

Views use two types of reference counting - regular and weak, and when there are no more regular references, the `view_flushanddetach()` function destroys or detaches some parts of the view, including `view->zonetable`, while other parts are freed by `destroy()` when the last weak reference is detached. Since catalog zones use weak references to attach a view, it's currently possible that during shutdown catalog zone processing will try to add a new zone into an otherwise unused view (because it's shutting down) which doesn't have an attached zonetable any more. This could cause an assertion failure. Fix this issue by modifying the `dns_view_addzone()` function to expect that `view->zonetable` can be `NULL`, and in that case just return `ISC_R_SHUTTINGDOWN`. [\[GL #5138\]](#) [\[GL !10086\]](#)

- Fix RPZ race condition during a reconfiguration. 54bb8252e2  
 With RPZ in use, *named* could terminate unexpectedly because of a race condition when a reconfiguration command was received using *rndc*. This has been fixed. [GL #5146] [GL !10145]
- "CNAME and other data check" not applied to all types. aaaf2e989a  
 An incorrect optimization caused "CNAME and other data" errors not to be detected if certain types were at the same node as a CNAME. This has been fixed. [GL #5150] [GL !10101]
- Remove NSEC/DS/NSEC3 RRSIG check from *dns\_message\_parse*. b601cb32ee  
 Previously, when parsing responses, *named* incorrectly rejected responses without matching RRSIG records for NSEC/DS/NSEC3 records in the authority section. This rejection, if appropriate, should have been left for the validator to determine and has been fixed. [GL #5185] [GL !10143]
- Fix a logic error in *cache\_name()* ab047ff47f  
 A change in 6aba56ae8 (checking whether a rejected RRset was identical to the data it would have replaced, so that we could still cache a signature) inadvertently introduced cases where processing of a response would continue when previously it would have been skipped. [GL #5197] [GL !10159]
- Finalize removal of memory debug flags size and *mctx* [9.18] 853a966fe7  
 [GL !9607]
- Post [CVE-2024-12705] Performance Drop Fixes, Part 2. e811f444b7  
 [GL !10193]
- Post [CVE-2024-12705] Performance Drop Fixes. 8d96ff01d4  
 [GL !10128]
- Sync the TSAN CC, CFLAGS and LDFLAGS in the *respdiff:tsan* job. 22fd7c4eb4  
 [GL !10213]

## 15.14 BIND 9.18.34

### 15.14.1 New Features

- Print the expiration time of the stale records. f04168545d1  
 Print the expiration time of the stale RRsets in the cache dump. [GL !10062]

### 15.14.2 Removed Features

- Remove *--with-tuning=small/large* configuration option. 327b666c6d0  
 The configuration option *--with-tuning* has been removed as it is no longer required or desired. [GL !9959]

### 15.14.3 Feature Changes

- Reduce memory sizes of common structures. 008e5201098
  - Reduce *sizeof(isc\_sockaddr\_t)* from 152 to 48 bytes
  - Reduce *sizeof(struct isc\_nm\_uvreq)* from 1560 to 560 bytes
 Partial backport of !8299 [GL !9953]

- Refactor reference counting in RBTDB. `fd9a85addc4`  
Clean up the pattern in the `newref()` and `decref()` functions in RBTDB databases.  
Related to #5134 [GL !10036]
- Shutdown the fetch context after canceling the last fetch. `57187b2c4f4`  
Shutdown the fetch context immediately after the last fetch has been canceled from that particular fetch context.  
[GL !9960]

### 15.14.4 Bug Fixes

- Fix "rndc flushname" for longer name server names. `b7383e50484`  
`rndc flushname` did not work for name server names longer than 16 bytes. This has been fixed. [GL #3885] [GL !10025]
- Recently expired records could be returned with timestamp in future. `4c49d99d560`  
Under rare circumstances, the RRSet that expired at the time of the query could be returned with TTL far in the future. This has been fixed.  
As a side-effect, the expiration time of expired RRsets are no longer printed out in the cache dump. [GL #5094] [GL !10060]
- Yaml string not terminated in negative response in delv. `132947c0bad`  
[GL #5098] [GL !9980]
- Apply the memory limit only to ADB database items. `7c90bd5bb3d`  
Resolver under heavy-load could exhaust the memory available for storing the information in the Address Database (ADB) effectively evicting already stored information in the ADB. The memory used to retrieve and provide information from the ADB is now not a subject of the same memory limits that are applied for storing the information in the Address Database. [GL #5127] [GL !9976]
- Avoid unnecessary locking in the zone/cache database. `43c77d95f1d`  
Prevent lock contention among many worker threads referring to the same database node at the same time. This would improve zone and cache database performance for the heavily contended database nodes. [GL #5130] [GL !9965]
- Fix the cache `findzonecut()` implementation. `368315b3c7e`  
The search for the deepest known zone cut in the cache could improperly reject a node if it contained any stale data, regardless of whether it was the NS RRset that was stale. [GL #5155] [GL !10051]
- Improve the resolver performance under attack. `2c667bc9c61`  
A remote client can force the DNS resolver component to consume the memory faster than cleaning up the resources for the canceled resolver fetches due to *recursive-clients* limit. If the such traffic pattern is sustained for a long period of time, the DNS server might eventually run out of the available memory. This has been fixed.  
It should be noted that when under such heavy attack for BIND 9 version both with and without the fix, no outgoing DNS queries will be successful as the generated traffic pattern will consume all the available slots for the recursive clients. [GL !9961]

## 15.15 BIND 9.18.33

### 15.15.1 Security Fixes

- [CVE-2024-12705] DNS-over-HTTP(s) flooding fixes. `e733e624147`

Fix DNS-over-HTTP(S) implementation issues that arise under heavy query load. Optimize resource usage for *named* instances that accept queries over DNS-over-HTTP(S).

Previously, *named* would process all incoming HTTP/2 data at once, which could overwhelm the server, especially when dealing with clients that send requests but don't wait for responses. That has been fixed. Now, *named* handles HTTP/2 data in smaller chunks and throttles reading until the remote side reads the response data. It also throttles clients that send too many requests at once.

Additionally, *named* now carefully processes data sent by some clients, which can be considered "flooding." It logs these clients and drops connections from them. [GL #4795]

In some cases, *named* could leave DNS-over-HTTP(S) connections in the *CLOSE\_WAIT* state indefinitely. That also has been fixed. ISC would like to thank JF Billaud for thoroughly investigating the issue and verifying the fix. [GL #5083] [GL #4795] [GL #5083]

- [CVE-2024-11187] Limit the additional processing for large RDATA sets. `c6e6a7af8ac`

When answering queries, don't add data to the additional section if the answer has more than 13 names in the RDATA. This limits the number of lookups into the database(s) during a single client query, reducing query processing load. [GL #5034]

### 15.15.2 New Features

- Add a new option to configure the maximum number of outgoing queries per client request. `64b2b6edffa`

The configuration option 'max-query-count' sets how many outgoing queries per client request is allowed. The existing 'max-recursion-queries' is the number of permissible queries for a single name and is reset on every CNAME redirection. This new option is a global limit on the client request. The default is 200.

This allows us to send a bit more queries while looking up a single name. The default for 'max-recursion-queries' is changed from 32 to 50. [GL #4980] [GL #4921] [GL !9847]

### 15.15.3 Feature Changes

- Update `picohttpparser.{c,h}` with upstream repository. `326b445e469`

[GL #4485] [GL !9864]

- Remove unused `maxquerycount`. `c30067bb2f3`

Related to #4980 [GL !9854]

- Use query counters in validator code. `b1207ea9ed6`

Commit `af7db8951364a89c468eda1535efb3f53adc2c1f` as part of #4141 was supposed to apply the 'max-recursion-queries' quota to validator queries, but the counter was never actually passed on to `'dns_resolver_createfetch()'`. This has been fixed, and the global query counter ('max-query-count', per client request) is now also added.

Related to #4980 [GL !9867]

### 15.15.4 Bug Fixes

- Fix `nsupdate` hang when processing a large update. `9a0588f7cf2`

To mitigate DNS flood attacks over a single TCP connection, we throttle the connection when the other side does not read the data. Throttling should only occur on server-side sockets, but erroneously also happened for `nsupdate`, which acts as a client. When `nsupdate` started throttling the connection, it never attempts to read again. This has been fixed. [GL #4910] [GL !9835]

- Fix possible assertion failure when reloading server while processing updates. 1d4e60c9ba9

[GL #5006] [GL !9821]

- Fix dnssec-signzone signing non-DNSKEY RRsets with revoked keys. bf2f4d4aad8

*dnssec-signzone* was using revoked keys for signing RRsets other than DNSKEY. This has been corrected. [GL #5070] [GL !9841]

- Unknown directive in resolv.conf not handled properly. 75ae186fa1f

The line after an unknown directive in resolv.conf could accidentally be skipped, potentially affecting dig, host, nslookup, nsupdate, or delv. This has been fixed. [GL #5084] [GL !9878]

- Fix a bug in isc\_rwlock\_trylock() f68e60b3dc4

When `isc_rwlock_trylock()` fails to get a read lock because another writer was faster, it should wake up other waiting writers in case there are no other readers, but the current code forgets about the currently active writer when evaluating 'cntflag'.

Unset the WRITER\_ACTIVE bit in 'cntflag' before checking to see if there are other readers, otherwise the waiting writers, if they exist, might not wake up. [GL #5121] [GL !9937]

## 15.16 BIND 9.18.32

### 15.16.1 New Features

- Update bind.keys with the new 2025 IANA root key. 1303fe5ea0

Add an 'initial-ds' entry to bind.keys for the new root key, ID 38696, which is scheduled for publication in January 2025. [GL #4896] [GL !9747]

- Support jinja2 templates in pytest runner. fa2ff6b690

Configuration files in system tests which require some variables (e.g. port numbers) filled in during test setup, can now use jinja2 templates when *jinja2* python package is available.

Any \*.j2 file found within the system test directory will be automatically rendered with the environment variables into a file without the .j2 extension by the pytest runner. E.g. *ns1/named.conf.j2* will become *ns1/named.conf* during test setup. To avoid automatic rendering, use *.j2.manual* extension and render the files manually at test time.

New *templates* pytest fixture has been added. Its *render()* function can be used to render a template with custom test variables. This can be useful to fill in different config options during the test. With advanced jinja2 template syntax, it can also be used to include/omit entire sections of the config file rather than using *named1.conf.in*, *named2.conf.in* etc. [GL #4938] [GL !9700]

### 15.16.2 Removed Features

- Move contributed DLZ modules into a separate repository. 8bc6a92111

The DLZ modules are poorly maintained as we only ensure they can still be compiled, the DLZ interface is blocking, so anything that blocks the query to the database blocks the whole server and they should not be used except in testing. The DLZ interface itself is going to be scheduled for removal.

The DLZ modules now live in <https://gitlab.isc.org/isc-projects/dlz-modules> repository. [GL #4865] [GL !9778]

### 15.16.3 Feature Changes

- Use lists of expected artifacts in system tests. `d9a140d5e8`  
`clean.sh` scripts have been replaced by lists of expected artifacts for each system test module. The list is defined using the custom `pytest.mark.extra_artifacts` mark, which can use both filenames and globs. [\[GL #4261\]](#) [\[GL !9735\]](#)
- Add two new clang-format options that help with code formatting. `aa10ae45fd`
  - Add new clang-format option to remove redundant semicolons
  - Add new clang-format option to remove redundant parentheses[\[GL !9751\]](#)
- Emit more helpful log for exceeding max-records-per-type. `99328b7369`  
The new log message is emitted when adding or updating an RRset fails due to exceeding the max-records-per-type limit. The log includes the owner name and type, corresponding zone name, and the limit value. It will be emitted on loading a zone file, inbound zone transfer (both AXFR and IXFR), handling a DDNS update, or updating a cache DB. It's especially helpful in the case of zone transfer, since the secondary side doesn't have direct access to the offending zone data.  
It could also be used for max-types-per-name, but this change doesn't implement it yet as it's much less likely to happen in practice. [\[GL !9772\]](#)
- Harden key management when key files have become unavailable. `f60f153b8a`  
Prior to doing key management, BIND 9 will check if the key files on disk match the expected keys. If key files for previously observed keys have become unavailable, this will prevent the internal key manager from running. [\[GL !9623\]](#)
- Revert "Fix NSEC3 closest encloser lookup for names with empty non-terminals" `56d1ccbdba`  
The fix for #4950 should have never been backported to 9.18. Revert the change.  
This reverts MR !9632  
History: A performance improvement for NSEC3 closest encloser lookups (#4460) was introduced (in MR !9436) and backported to 9.20 (MR !9438) and to 9.18 in (MR !9439). It was released in 9.18.30 (and 9.20.2 and 9.21.1). There was a bug in the code (#4950), so we reverted the change in !9611, !9613 and !9614 (not released). Then a new attempt was merged in main (MR !9610) and backported to 9.20 (MR !9631) and 9.18 (MR !9632). The latter should not have been backported.  
Furthermore, the initial MR used the wrong MR title so the change was never added to the release note. This is done in main with MR !9598 and backports to 9.20 (MR !9615) and 9.18 (MR !9616).  
The new release notes for 9.21 and 9.20 should probably say that the bug is fixed. The new release notes for 9.18 should probably say that the change is reverted. [\[GL !9689\]](#)

### 15.16.4 Bug Fixes

- '{&dns}' is as valid as '{?dns}' in a SVCB's dohpath. `4b0114ffce`  
*dig* fails to parse a valid (as far as I can tell, and accepted by *kdig* and *Wireshark*) SVCB record with a *dohpath* URI template containing a *{&dns}*, like *dohpath=/some/path?key=value{&dns}'*. If the URI template contains a *{?dns}* instead *dig* is happy, but my understanding of rfc9461 and section 1.2. "Levels and Expression Types" of rfc6570 is that *{&dns}* is valid. See for example section 1.2. "Levels and Expression Types" of rfc6570.

Note that Peter van Dijk suggested that *{dns}* and *{dns,someothervar}* might be valid forms as well, so my patch might be too restrictive, although it's anyone's guess how DoH clients would handle complex templates. [GL #4922] [GL !9770]

- Fix NSEC3 closest encloser lookup for names with empty non-terminals. 9d59c72798

The performance improvement for finding the NSEC3 closest encloser when generating authoritative responses could cause servers to return incorrect NSEC3 records in some cases. This has been fixed. [GL #4950] [GL !9632]

- Revert "Improve performance when looking for the closest encloser" 257fd7eca0

Revert "fix: chg: Improve performance when looking for the closest encloser when returning NSEC3 proofs"

This reverts merge request !9436 [GL #4950] [GL !9614]

- Restore values when dig prints command line. 002141af2e

Options of the form *[+-]option=<value>* failed to display the value on the printed command line. This has been fixed. [GL #4993] [GL !9667]

- Provide more visibility into configuration errors. f63a0ebdfe

by logging `SSL_CTX_use_certificate_chain_file` and `SSL_CTX_use_PrivateKey_file` errors individually. [GL #5008] [GL !9768]

- Fix error path bugs in the manager's "recursing-clients" list management. eda40c3685

In two places, after linking the client to the manager's "recursing-clients" list using the `check_recursionquota()` function, the `query.c` module fails to unlink it on error paths. Fix the bugs by unlinking the client from the list. [GL !9605]

- Remove unused `<openssl/{hmac,engine}.h>` headers from OpenSSL shims. 7bb817d1b6

The `<openssl/{hmac,engine}.h>` headers were unused and including the `<openssl/engine.h>` header might cause build failure when OpenSSL doesn't have Engines support enabled.

See <https://fedoraproject.org/wiki/Changes/OpensslDeprecateEngine> [GL !9645]

- Use `attach()/detach()` functions instead of touching `.references`. 9712d00cb0

In `rbtdb.c`, there were two places where the code touched `.references` directly instead of using the helper functions. Use the helper functions instead.

Forward port from [https://gitlab.isc.org/isc-private/bind9/-/merge\\_requests/753](https://gitlab.isc.org/isc-private/bind9/-/merge_requests/753) [GL !9796]

## 15.17 BIND 9.18.31

### 15.17.1 New Features

- Added WALLETT type. 65d9f28b32d

Add the new record type WALLETT (262). This provides a mapping from a domain name to a cryptographic currency wallet. Multiple mappings can exist if multiple records exist. [GL #4947] [GL !9555]

### 15.17.2 Feature Changes

- Allow IXFR-to-AXFR fallback on `DNS_R_TOOMANYRECORDS`. 1d6465ff169

This change allows fallback from an IXFR failure to AXFR when the reason is `DNS_R_TOOMANYRECORDS`. This is because this error condition could be temporary only in an intermediate version of IXFR transactions and it's possible that the latest version of the zone doesn't have that condition. In such a case, the secondary would never be able to update the zone (even if it could) without this fallback.

This fallback behavior is particularly useful with the recently introduced *max-records-per-type* and *max-types-per-name* options: the primary may not have these limitations and may temporarily introduce "too many" records, breaking IXFR. If the primary side subsequently deletes these records, this fallback will help recover the zone transfer failure automatically; without it, the secondary side would first need to increase the limit, which requires more operational overhead and has its own adverse effect. [GL #4928] [GL !9472]

- Remove statslock from dnssec-signzone. 5c51e044c42

Silence Coverity CID 468757 and 468767 (DATA RACE read not locked) by converting dnssec-signzone to use atomics for statistics counters rather than using a lock. [GL #4939] [GL !9501]

- Use release memory ordering when incrementing reference counter. b2bbceecfe8

As the relaxed memory ordering doesn't ensure any memory synchronization, it is possible that the increment will succeed even in the case when it should not - there is a race between `atomic_fetch_sub(..., acq_rel)` and `atomic_fetch_add(..., relaxed)`. Only the result is consistent, but the previous value for both calls could be same when both calls are executed at the same time. [GL !9568]

### 15.17.3 Bug Fixes

- Fix a statistics channel counter bug when 'forward only' zones are used. 5a6c5218ad1

When resolving a zone with a 'forward only' policy, and finding out that all the forwarders are marked as "bad", the 'ServerQuota' counter of the statistics channel was incorrectly increased. This has been fixed. [GL #1793] [GL !9503]

- Fix a bug in the static-stub implementation. 1e5bc23921e

Static-stub addresses and addresses from other sources were being mixed together, resulting in static-stub queries going to addresses not specified in the configuration, or alternatively, static-stub addresses being used instead of the correct server addresses. [GL #4850] [GL !9572]

- Don't allow statistics-channel if libxml2 and libjson-c are unsupported. e8c2c9c9dca

When the libxml2 and libjson-c libraries are not supported, the statistics channel can't return anything useful, so it is now disabled. Use of *statistics-channel* in *named.conf* is a fatal error. [GL #4895] [GL !9487]

- Limit the outgoing UDP send queue size. 6c1fc4ae544

If the operating system UDP queue gets full and the outgoing UDP sending starts to be delayed, BIND 9 could exhibit memory spikes as it tries to enqueue all the outgoing UDP messages. Try a bit harder to deliver the outgoing UDP messages synchronously and if that fails, drop the outgoing DNS message that would get queued up and then timeout on the client side. [GL #4930] [GL !9512]

- Do not set SO\_INCOMING\_CPU. 694cb11a173

We currently set SO\_INCOMING\_CPU incorrectly, and testing by Ondrej shows that fixing the issue by setting affinities is worse than letting the kernel schedule threads without constraints. So we should not set SO\_INCOMING\_CPU anymore. [GL #4936] [GL !9505]

- Don't enable REUSEADDR on outgoing UDP sockets. b902a4e214a

The outgoing UDP sockets enabled *SO\_REUSEADDR* that allows sharing of the UDP sockets, but with one big caveat - the socket that was opened the last would get all traffic. The dispatch code would ignore the invalid responses in the `dns_dispatch`, but this could lead to unexpected results. [GL !9584]

## 15.18 BIND 9.18.30

### 15.18.1 New Features

- Print the full path of the working directory in startup log messages. 99ce0d6b838

named now prints its initial working directory during startup and the changed working directory when loading or reloading its configuration file if it has a valid 'directory' option defined. [\[GL #4731\]](#) [\[GL !9373\]](#)

### 15.18.2 Feature Changes

- Restore the ability to select individual unit tests. [a59fe212a34](#)

This adds the command line arguments: *-d* (debug), *-l* (list tests) and *-t test* (run this test) to the unit tests.

e.g.

```
% ./rdata_test -t zonemd
[=====] selected:
Running 1 test(s) .
[ RUN      ] zonemd
[         OK ] zonemd
[=====] selected: 1 test(s) run.
[ PASSED   ] 1 test(s) .
%
```

[\[GL #4579\]](#) [\[GL !9386\]](#)

- Process also the ISC\_R\_CANCELED result code in `rpz_rewrite()` [26df9f6255b](#)

Log canceled resolver queries (e.g. when shutting down a hung fetch) in DEBUG3 level instead of DEBUG1 which is used for the "unrecognized" result codes. [\[GL #4797\]](#) [\[GL !9348\]](#)

- Remove code to read and parse `/proc/net/if_inet6` on Linux. [887a61a4082](#)

The `getifaddr()` works fine for years, so we don't have to keep the callback to parse `/proc/net/if_inet6` anymore. [\[GL #4852\]](#) [\[GL !9342\]](#)

- Follow the number of CPU set by `taskset/cpuset`. [17efe703cc2](#)

Administrators may wish to constrain the set of cores that BIND 9 runs on via the 'taskset', 'cpuset' or 'numactl' programs (or equivalent on other O/S).

If the admin has used `taskset`, the *named* will now follow to automatically use the given number of CPUs rather than the system wide count. [\[GL #4884\]](#) [\[GL !9443\]](#)

### 15.18.3 Bug Fixes

- Change the NS\_PER\_SEC (and friends) from enum to #define. [0da22fc138e](#)

New version of clang (19) has introduced a stricter checks when mixing integer (and float types) with enums. In this case, we used `enum {}` as C17 doesn't have `constexpr` yet. Change the time conversion constants to be #defined constants because of RHEL 8 compiler doesn't consider static `const unsigned int` to be constant. [\[GL #4845\]](#) [\[GL !9340\]](#)

- Check the result of `dirfd()` before calling `unlinkat()` [b9f0df60972](#)

Instead of directly using the result of `dirfd()` in the `unlinkat()` call, check whether the returned file descriptor is actually valid. That doesn't really change the logic as the `unlinkat()` would fail with invalid descriptor anyway, but this is cleaner and will report the right error returned directly by `dirfd()` instead of EBADF from `unlinkat()`. [\[GL #4853\]](#) [\[GL !9344\]](#)

- Checking whether a EDDSA key was private or not was broken. [e04839c08e8](#)

Checking whether a EDDSA key was private or not was broken could lead to attempting to sign records with a public key and this could cause a segmentation failure (read of a NULL pointer) within OpenSSL. [\[GL #4855\]](#) [\[GL !9329\]](#)

- Fix algorithm rollover bug when there are two keys with the same keytag. [43c8ed45e53](#)

If there is an algorithm rollover and two keys of different algorithm share the same keytags, then there is a possibility that if we check that a key matches a specific state, we are checking against the wrong key. This has been fixed by not only checking for matching key tag but also key algorithm. [\[GL #4878\]](#) [\[GL !9394\]](#)

- Stop using `malloc_usable_size` and `malloc_size`. [cccd26e942c](#)

The `malloc_usable_size()` can return size larger than originally allocated and when these sizes disagree the fortifier enabled by `_FORTIFY_SOURCE=3` detects overflow and stops the *named* execution abruptly. Stop using these convenience functions as they are primary used for introspection-only. [\[GL #4880\]](#) [\[GL !9419\]](#)

- Preserve statement tag order in documentation. [b4d1988c280](#)

This supports bit-for-bit reproducibility of built documentation. [\[GL #4886\]](#) [\[GL !9409\]](#)

- Fix clang-scan 19 warnings. [01ee251d130](#)

Silence warnings generated by clang-scan. [\[GL !9388\]](#)

## 15.19 BIND 9.18.29

### 15.19.1 New Features

- Tighten 'max-recursion-queries' and add 'max-query-restarts' option. [fe3ae71e90](#)

There were cases in `resolver.c` when the *max-recursion-queries* quota was ineffective. It was possible to craft zones that would cause a resolver to waste resources by sending excessive queries while attempting to resolve a name. This has been addressed by correcting errors in the implementation of *max-recursion-queries*, and by reducing the default value from 100 to 32.

In addition, a new *max-query-restarts* option has been added which limits the number of times a recursive server will follow CNAME or DNAME records before terminating resolution. This was previously a hard-coded limit of 16, and now defaults to 11. [\[GL #4741\]](#) [\[GL !9283\]](#)

- Generate changelog from git log. [21a0b6aef7](#)

Use a single source of truth, the git log, to generate the list of CHANGES. Use the `.rst` format and include it in the ARM for a quick reference with proper gitlab links to issues and merge requests. [\[GL #75\]](#) [\[GL !9181\]](#)

### 15.19.2 Feature Changes

- Use `_exit()` in the `fatal()` function. [e4c483f45f](#)

Since the `fatal()` isn't a correct but rather abrupt termination of the program, we want to skip the various `atexit()` calls because not all memory might be freed during `fatal()` call, etc. Using `_exit()` instead of `exit()` has this effect - the program will end, but no destructors or `atexit` routines will be called. [\[GL !9263\]](#)

- Fix data race in `clean_finds_at_name`. [541726871d](#)

Stop updating `find.result_v4` and `find.result_v4` in `clean_finds_at_name`. The values are supposed to be static. [\[GL #4118\]](#) [\[GL !9198\]](#)

### 15.19.3 Bug Fixes

- Reconfigure `catz` member zones during named reconfiguration. [944d0dc942](#)

During a reconfiguration named wasn't reconfiguring catalog zones' member zones. This has been fixed. [\[GL #4733\]](#)

- Disassociate the SSL object from the cached SSL\_SESSION. 64fde41253  
When the SSL object was destroyed, it would invalidate all SSL\_SESSION objects including the cached, but not yet used, TLS session objects.  
Properly disassociate the SSL object from the SSL\_SESSION before we store it in the TLS session cache, so we can later destroy it without invalidating the cached TLS sessions. [GL #4834] [GL !9279]
- Attach/detach to the listening child socket when accepting TLS. 3ead47daff  
When TLS connection (TLSstream) connection was accepted, the children listening socket was not attached to sock->server and thus it could have been freed before all the accepted connections were actually closed.  
In turn, this would cause us to call isc\_tls\_free() too soon - causing cascade errors in pending SSL\_read\_ex() in the accepted connections.  
Properly attach and detach the children listening socket when accepting and closing the server connections. [GL #4833] [GL !9278]
- Make hypothesis optional for system tests. 0d1953d7a8  
Ensure that system tests can be executed without Python hypothesis package. [GL #4831] [GL !9268]
- Don't loop indefinitely when isc\_task quantum is 'unlimited' 674420df64  
Don't run more events than already scheduled. If the quantum is set to a high value, the task\_run() would execute already scheduled, and all new events that result from running event->ev\_action().  
Setting quantum to a number of scheduled events will postpone events scheduled after we enter the loop here to the next task\_run() invocation. [GL !9257]
- Raise the log level of priming failures. c948babeeb  
When a priming query is complete, it's currently logged at level ISC\_LOG\_DEBUG(1), regardless of success or failure. We are now raising it to ISC\_LOG\_NOTICE in the case of failure. [GL #3516] [GL #3516] [GL !9251]
- Add a compatibility shim for older libuv versions (< 1.19.0) 61ff983f00  
The uv\_stream\_get\_write\_queue\_size() is supported only in relatively newer versions of libuv (1.19.0 or higher). Provide a compatibility shim for this function, so BIND 9 can be built in environments with older libuv version.
- Remove extra newline from yaml output. 1222dbe9f9  
I split this into two commits, one for the actual newline removal, and one for issues I found, ruining the yaml output when some errors were outputted.
- CID 498025 and CID 498031: Overflowed constant INTEGER\_OVERFLOW. bdd888b8e  
Add INSIST to fail if the multiplication would cause the variables to overflow. [GL #4798] [GL !9230]
- Remove unnecessary operations. 2374a1a2bd  
Decrementing optlen immediately before calling continue is unnecessary and inconsistent with the rest of dns\_message\_pseudosectiontoyaml and dns\_message\_pseudosectiontotext. Coverity was also reporting an impossible false positive overflow of optlen (CID 499061). [GL !9224]
- Fix generation of 6to4-self name expansion from IPv4 address. df55c15ebb  
The period between the most significant nibble of the encoded IPv4 address and the 2.0.0.2.IP6.ARPA suffix was missing resulting in the wrong name being checked. Add system test for 6to4-self implementation. [GL #4766] [GL !9218]
- Fix false QNAME minimisation error being reported. 4984afc80c  
Remove the false positive "success resolving" log message when QNAME minimisation is in effect and the final result is NXDOMAIN. [GL #4784] [GL !9216]

- Dig +yaml was producing unexpected and/or invalid YAML output. 2db62a4dba  
[GL #4796] [GL !9214]
- SVBC alpn text parsing failed to reject zero length alpn. 8f7be89052  
[GL #4775] [GL !9210]
- Return SERVFAIL for a too long CNAME chain. f7de909b98  
When cutting a long CNAME chain, named was returning NOERROR instead of SERVFAIL (alongside with a partial answer). This has been fixed. [GL #4449] [GL !9204]
- Properly calculate the amount of system memory. 9faf355a5c  
On 32 bit machines isc\_meminfo\_totalphys could return an incorrect value. [GL #4799] [GL !9200]
- Update key lifetime and metadata after dnssec-policy reconfig. 2107a64ee6  
Adjust key state and timing metadata if dnssec-policy key lifetime configuration is updated, so that it also affects existing keys. [GL #4677] [GL !9192]
- Fix dig +timeout argument when using +https. 381d6246d6  
The +timeout argument was not used on DoH connections. This has been fixed. [GL #4806] [GL !9161]

## 15.20 Changes prior to 9.18.29

```

--- 9.18.28 released ---

6404.  [security]      Remove SIG(0) support from named as a countermeasure
                        for CVE-2024-1975. [GL #4480]

6403.  [security]      qctx-zversion was not being cleared when it should have
                        been leading to an assertion failure if it needed to be
                        reused. (CVE-2024-4076) [GL #4507]

6401.  [security]      An excessively large number of rrtypes per owner can
                        slow down database query processing, so a limit has been
                        placed on the number of rrtypes that can be stored per
                        owner (node) in a cache or zone database. This is
                        configured with the new "max-rrtypes-per-name" option,
                        and defaults to 100. (CVE-2024-1737)
                        [GL #3403] [GL #4548]

6400.  [security]      Excessively large rdatasets can slow down database
                        query processing, so a limit has been placed on the
                        number of records that can be stored per rdataset
                        in a cache or zone database. This is configured
                        with the new "max-records-per-type" option, and
                        defaults to 100. (CVE-2024-1737)
                        [GL #497] [GL #3405]

6399.  [security]      Malicious DNS client that sends many queries over
                        TCP but never reads responses can cause server to
                        respond slowly or not respond at all for other
                        clients. (CVE-2024-0760) [GL #4481]

```

(continues on next page)

(continued from previous page)

6398.	[bug]	Fix potential data races in our DoH implementation related to HTTP/2 session object management and endpoints set object management after reconfiguration. We would like to thank Dzintars and Ivo from nic.lv for bringing this to our attention. [GL #4473]
6397.	[bug]	Clear DNS_FETCHOPT_TRYSTALE_ONTIMEOUT when looking for parent NS records needed to get the DS result. [GL #4661]
6395.	[bug]	Handle ISC_R_HOSTDOWN and ISC_R_NETDOWN in resolver.c. [GL #4736]
6394.	[bug]	Named's -4 and -6 options now apply to zone primaries, also-notify and parental-agents. Report when a zone has these options configured but does not have an IPv4 or IPv6 address listed respectively. [GL #3472]
6393.	[func]	Deal with uv_tcp_close_reset() error return codes more gracefully. [GL #4708]
6392.	[bug]	Use a completely new memory context when flushing the cache. [GL #2744]
6391.	[bug]	TCP client statistics could sometimes fail to decrease when accepting client connection fails. [GL #4742]
6390.	[bug]	Fix a data race in isc_task_purgeevent(). [GL #8937]
6389.	[bug]	dnssec-verify and dnssec-signzone could fail if there was an obscured DNSKEY RRset at a delegation. [GL #4517]
6388.	[bug]	Prevent an assertion failure caused by passing NULL to dns_dispatch_resume() when a dns_request times out close to view shutdown. [GL #4719]
6386.	[bug]	When shutting down catzs->view could point to freed memory. Obtain a reference to the view to prevent this. [GL #4502]
6385.	[func]	Relax SVCB alias mode checks to allow parameters. [GL #4704]
6384.	[bug]	Remove infinite loop when including a directory in a zone file. [GL #4357]
6383.	[bug]	Address an infinite loop in \$GENERATE when a negative value was converted in nibble mode. [GL #4353]
6382.	[bug]	Fix RPZ response's SOA record TTL, which was incorrectly set to 1 if 'add-soa' is used. [GL #3323]

--- 9.18.27 released ---

- 6374. [bug] Skip to next RRSIG if signature has expired or is in the future rather than failing immediately. [GL #4586]
- 6372. [func] Implement signature jitter for dnssec-policy. [GL #4554]

--- 9.18.26 released ---

- 6364. [protocol] Add RESOLVER.ARPA to the built in empty zones. [GL #4580]
- 6363. [bug] dig/mdig +ednsflags=<non-zero-value> did not re-enable EDNS if it had been disabled. [GL #4641]
- 6361. [bug] Some invalid ISO 8601 durations were accepted erroneously. [GL #4624]
- 6360. [bug] Don't return static-stub synthesised NS RRset. [GL #4608]
- 6359. [bug] Fix bug in Depends (keymgr\_dep) function. [GL #4552]
- 6351. [protocol] Support for the RESINFO record type has been added. [GL #4413]
- 6346. [bug] Cleaned up several minor bugs in the RBTDB dbiterator implementation. [GL !8741]
- 6345. [bug] Added missing dns\_rdataset\_disassociate calls in validator.c:findnsec3proofs. [GL #4571]
- 6340. [test] Fix incorrectly reported errors when running tests with `make test` on platforms with older pytest. [GL #4560]
- 6338. [func] Optimize slabheader placement, so the infrastructure records are put in the beginning of the slabheader linked list. [GL !8675]
- 6334. [doc] Improve ARM parental-agents definition. [GL #4531]
- 6333. [bug] Fix the DNS\_GETDB\_STALEFIRST flag, which was defined incorrectly in lib/ns/query.c. [GL !8683]
- 6330. [doc] Update ZSK minimum lifetime documentation in ARM, also depends on signing delay. [GL #4510]
- 6328. [func] Add workaround to enforce dynamic linker to pull jemalloc earlier than libc to ensure all memory allocations are done via jemalloc. [GL #4404]

(continues on next page)

(continued from previous page)

6326.	[bug]	Changes to "listen-on" statements were ignored on reconfiguration unless the port or interface address was changed, making it impossible to change a related listener transport type. Thanks to Thomas Amgarten. [GL #4518] [GL #4528]
6325.	[func]	Expose the TCP client count in statistics channel. [GL #4425]
6324.	[bug]	Fix a possible crash in 'dig +nssearch +nofail' and 'host -C' commands when one of the name servers returns SERVFAIL. [GL #4508]
6313.	[bug]	When dnssec-policy is in effect the DNSKEY's TTLs in the zone where not being updated to match the policy. This lead to failures when DNSKEYs where updated as the TTLs mismatched. [GL #4466]

--- 9.18.25 released ---

6356.	[bug]	Create the pruning task in the dns_cache_flush(), so the cache pruning still works after the flush. [GL #4621]
6353.	[bug]	Improve the TTL-based cleaning by removing the expired headers from the heap, so they don't block the next cleaning round and clean more than a single item for each new addition to the RBTDB. [GL #4591]
6352.	[bug]	Revert change 6319 and decrease lock contention during RBTDB tree pruning by not cleaning up nodes recursively within a single prune_tree() call. [GL #4596]
6350.	[bug]	Address use after free in expire_lru_headers. [GL #4495]

--- 9.18.24 released ---

6343.	[bug]	Fix case insensitive setting for isc_ht hashtable. [GL #4568]
-------	-------	---

--- 9.18.23 released ---

6322.	[security]	Specific DNS answers could cause a denial-of-service condition due to DNS validation taking a long time. (CVE-2023-50387) [GL #4424]
		The same code change also addresses another problem: preparing NSEC3 closest encloser proofs could exhaust available CPU resources. (CVE-2023-50868) [GL #4459]
6321.	[security]	Change 6315 inadvertently introduced regressions that

(continues on next page)

(continued from previous page)

could cause named to crash. [GL #4234]

6320. [bug] Under some circumstances, the DoT code in client mode could process more than one message at a time when that was not expected. That has been fixed. [GL #4487]

--- 9.18.22 released ---

6319. [func] Limit isc\_task\_send() overhead for RBTDB tree pruning. [GL #4383]

6317. [security] Restore DNS64 state when handling a serve-stale timeout. (CVE-2023-5679) [GL #4334]

6316. [security] Specific queries could trigger an assertion check with nxdomain-redirect enabled. (CVE-2023-5517) [GL #4281]

6315. [security] Speed up parsing of DNS messages with many different names. (CVE-2023-4408) [GL #4234]

6314. [bug] Address race conditions in dns\_tsigkey\_find(). [GL #4182]

6312. [bug] Conversion from NSEC3 signed to NSEC signed could temporarily put the zone into a state where it was treated as unsigned until the NSEC chain was built. Additionally conversion from one set of NSEC3 parameters to another could also temporarily put the zone into a state where it was treated as unsigned until the new NSEC3 chain was built. [GL #1794] [GL #4495]

6310. [bug] Memory leak in zone.c:sign\_zone. When named signed a zone it could leak dst\_keys due to a misplaced 'continue'. [GL #4488]

6306. [func] Log more details about the cause of "not exact" errors. [GL #4500]

6304. [bug] The wrong time was being used to determine what RRSIGs where to be generated when dnssec-policy was in use. [GL #4494]

6302. [func] The "trust-anchor-telemetry" statement is no longer marked as experimental. This silences a relevant log message that was emitted even when the feature was explicitly disabled. [GL #4497]

6300. [bug] Fix statistics export to use full 64 bit signed numbers instead of truncating values to unsigned 32 bits. [GL #4467]

6299. [port] NetBSD has added 'hmac' to libc which collides with our

(continues on next page)

(continued from previous page)

use of 'hmac'. [GL #4478]

--- 9.18.21 released ---

- 6297. [bug] Improve LRU cleaning behaviour. [GL #4448]
- 6296. [func] The "resolver-nonbackoff-tries" and "resolver-retry-interval" options are deprecated; a warning will be logged if they are used. [GL #4405]
- 6294. [bug] BIND might sometimes crash after startup or re-configuration when one 'tls' entry is used multiple times to connect to remote servers due to initialisation attempts from contexts of multiple threads. That has been fixed. [GL #4464]
- 6290. [bug] Dig +yaml will now report "no servers could be reached" also for UDP setup failure when no other servers or tries are left. [GL #1229]
- 6287. [bug] Recognize escapes when reading the public key from file. [GL !8502]
- 6286. [bug] Dig +yaml will now report "no servers could be reached" on TCP connection failure as well as for UDP timeouts. [GL #4396]
- 6282. [func] Deprecate AES-based DNS cookies. [GL #4421]

--- 9.18.20 released ---

- 6280. [bug] Fix missing newlines in the output of "rndc nta -dump". [GL !8454]
- 6277. [bug] Take into account local authoritative zones when falling back to serve-stale. [GL #4355]
- 6275. [bug] Fix assertion failure when using lock-file configuration option together -X argument to named. [GL #4386]
- 6274. [bug] The 'lock-file' file was being removed when it shouldn't have been making it ineffective if named was started 3 or more times. [GL #4387]
- 6271. [bug] Fix a shutdown race in dns\_\_catz\_update\_cb(). [GL #4381]
- 6269. [maint] B.ROOT-SERVERS.NET addresses are now 170.247.170.2 and 2801:1b8:10::b. [GL #4101]
- 6267. [func] The timeouts for resending zone refresh queries over UDP were lowered to enable named to more quickly determine

(continues on next page)

(continued from previous page)

		that a primary is down. [GL #4260]
6265.	[bug]	Don't schedule resign operations on the raw version of an inline-signing zone. [GL #4350]
6261.	[bug]	Fix a possible assertion failure on an error path in resolver.c:fctx_query(), when using an uninitialized link. [GL #4331]
6254.	[cleanup]	Add semantic patch to do an explicit cast from char to unsigned char in ctype.h class of functions. [GL #4327]
6252.	[test]	Python system tests have to be executed by invoking pytest directly. Executing them with the legacy test runner is no longer supported. [GL #4250]
6250.	[bug]	The wrong covered value was being set by dns_ncache_current for RRSIG records in the returned rdataset structure. This resulted in TYPE0 being reported as the covered value of the RRSIG when dumping the cache contents. [GL #4314]

		--- 9.18.19 released ---
6246.	[security]	Fix use-after-free error in TLS DNS code when sending data. (CVE-2023-4236) [GL #4242]
6245.	[security]	Limit the amount of recursion that can be performed by isccc_cc_fromwire. (CVE-2023-3341) [GL #4152]
6244.	[bug]	Adjust log levels on malformed messages to NOTICE when transferring in a zone. [GL #4290]
6241.	[bug]	Take into account the possibility of partial TLS writes in TLS DNS code. That helps to prevent DNS messages corruption on long DNS over TLS streams. [GL #4255]
6240.	[bug]	Use dedicated per-worker thread jemalloc memory arenas for send buffers allocation to reduce memory consumption and avoid lock contention. [GL #4038]
6239.	[func]	Deprecate the 'dnssec-must-be-secure' option. [GL #3700]
6237.	[bug]	Address memory leaks due to not clearing OpenSSL error stack. [GL #4159]
6235.	[doc]	Clarify BIND 9 time formats. [GL #4266]
6234.	[bug]	Restore stale-refresh-time value after flushing the cache. [GL #4278]

(continues on next page)

(continued from previous page)

- 6232. [bug] Following the introduction of krb5-subdomain-self-rhs and ms-subdomain-self-rhs update rules, removal of nonexistent PTR and SRV records via UPDATE could fail. [GL #4280]
- 6231. [func] Make nsupdate honor -v for SOA requests if the server is specified. [GL #1181]
- 6230. [bug] Prevent an unnecessary query restart if a synthesized CNAME target points to the CNAME owner. [GL #3835]
- 6227. [bug] Check the statistics-channel HTTP Content-length to prevent negative or overflowing values from causing a crash. [GL #4125]
- 6224. [bug] Check the If-Modified-Since value length to prevent out-of-bounds write. [GL #4124]

--- 9.18.18 released ---

- 6220. [func] Deprecate the 'dialup' and 'heartbeat-interval' options. [GL #3700]
- 6219. [bug] Ignore 'max-zone-ttl' on 'dnssec-policy insecure'. [GL #4032]
- 6215. [protocol] Return REFUSED to GSS-API TKEY requests if GSS-API support is not configured. [GL #4225]
- 6213. [bug] Mark a primary server as temporarily unreachable if the TCP connection attempt times out. [GL #4215]
- 6212. [bug] Don't process detach and close netmgr events when the netmgr has been paused. [GL #4200]

--- 9.18.17 released ---

- 6206. [bug] Add shutdown checks in dns\_catz\_dbupdate\_callback() to avoid a race with dns\_catz\_shutdown\_catzs(). [GL #4171]
- 6205. [bug] Restore support to read legacy HMAC-MD5 K file pairs. [GL #4154]
- 6204. [bug] Use NS records for relaxed QNAME-minimization mode. This reduces the number of queries named makes when resolving, as it allows the non-existence of NS RRsets at non-referral nodes to be cached in addition to the referrals that are normally cached. [GL #3325]
- 6200. [bug] Fix nslookup erroneously reporting a timeout when the

(continues on next page)

(continued from previous page)

		input is delayed. [GL #4044]
6199.	[bug]	Improve HTTP Connection: header protocol conformance in the statistics channel. [GL #4126]
6198.	[func]	Remove the holes in the <code>isc_result_t</code> enum to compact the <code>isc_result</code> tables. [GL #4149]
6197.	[bug]	Fix a data race between the <code>dns_zone</code> and <code>dns_catz</code> modules when registering/unregistering a database update notification callback for a catalog zone. [GL #4132]
6196.	[cleanup]	Report "permission denied" instead of "unexpected error" when trying to update a zone file on a read-only file system. Thanks to Midnight Veil. [GL #4134]
6193.	[bug]	Fix a <code>catz</code> db update notification callback registration logic error, which could crash <code>named</code> when receiving an AXFR update for a catalog zone while the previous update process of the catalog zone was already running. [GL #4136]
6166.	[func]	Retry without DNS COOKIE on FORMERR if it appears that the FORMERR was due to the presence of a DNS COOKIE option. [GL #4049]

		--- 9.18.16 released ---
6192.	[security]	A query that prioritizes stale data over lookup triggers a fetch to refresh the stale data in cache. If the fetch is aborted for exceeding the recursion quota, it was possible for 'named' to enter an infinite callback loop and crash due to stack overflow. This has been fixed. (CVE-2023-2911) [GL #4089]
6190.	[security]	Improve the overmem cleaning process to prevent the cache going over the configured limit. (CVE-2023-2828) [GL #4055]
6188.	[performance]	Reduce memory consumption by allocating properly sized send buffers for stream-based transports. [GL #4038]
6186.	[bug]	Fix a 'clients-per-query' miscalculation bug. When the 'stale-answer-enable' options was enabled and the 'stale-answer-client-timeout' option was enabled and larger than 0, <code>named</code> was taking two places from the 'clients-per-query' limit for each client and was failing to gradually auto-tune its value, as configured. [GL #4074]

(continues on next page)

(continued from previous page)

6185.	[func]	Add "ClientQuota" statistics channel counter, which indicates the number of the resolver's spilled queries due to reaching the clients per query quota. [GL !7978]
6183.	[bug]	Fix a serve-stale bug where a delegation from cache could be returned to the client. [GL #3950]
6182.	[cleanup]	Remove configure checks for epoll, kqueue and /dev/poll. [GL #4098]
6181.	[func]	The "tkey-dhkey" option has been deprecated; a warning will be logged when it is used. In a future release, Diffie-Hellman TKEY mode will be removed. [GL #3905]
6180.	[bug]	The session key object could be incorrectly added to multiple different views' keyrings. [GL #4079]
6179.	[bug]	Fix an interfacemgr use-after-free error in zoneconf.c:isself(). [GL #3765]
6176.	[test]	Add support for using pytest & pytest-xdist to execute the system test suite. [GL #3978]
6174.	[bug]	BIND could get stuck on reconfiguration when a 'listen' statement for HTTP is removed from the configuration. That has been fixed. [GL #4071]
6173.	[bug]	Properly process extra "nameserver" lines in resolv.conf otherwise the next line is not properly processed. [GL #4066]
6169.	[bug]	named could crash when deleting inline-signing zones with "rndc delzone". [GL #4054]
6165.	[bug]	Fix a logic error in dighost.c which could call the dighost_shutdown() callback twice and cause problems if the callback function was not idempotent. [GL #4039]

--- 9.18.15 released ---

6164.	[bug]	Set the rndc idle read timeout back to 60 seconds, from the netmgr default of 30 seconds, in order to match the behavior of 9.16 and earlier. [GL #4046]
6161.	[bug]	Fix log file rotation when using absolute path as file. [GL #3991]
6157.	[bug]	When removing delegations in an OPTOUT range empty-non-terminal NSEC3 records generated by those delegations were not removed. [GL #4027]

(continues on next page)

(continued from previous page)

6156.	[bug]	Reimplement the maximum and idle timeouts for incoming zone transfers. [GL #4004]
6155.	[bug]	Treat ISC_R_INVALIDPROTO as a networking error in the dispatch code to avoid retrying with the same server. [GL #4005]
6152.	[bug]	In dispatch, honour the configured source-port selection when UDP connection fails with address in use error.  Also treat ISC_R_NOPERM same as ISC_R_ADDRINUSE. [GL #3986]
6149.	[test]	As a workaround, include an OpenSSL header file before including cmocka.h in the unit tests, because OpenSSL 3.1.0 uses <code>__attribute__(malloc)</code> , conflicting with a redefined malloc in cmocka.h. [GL #4000]

--- 9.18.14 released ---		
6145.	[bug]	Fix a possible use-after-free bug in the <code>dns__catz_done_cb()</code> function. [GL #3997]
6143.	[bug]	A reference counting problem on the error path in the <code>xfrin_connect_done()</code> might cause an assertion failure on shutdown. [GL #3989]
6142.	[bug]	Reduce the number of <code>dns_dnssec_verify</code> calls made determining if revoked keys needs to be removed from the trust anchors. [GL #3981]
6141.	[bug]	Fix several issues in <code>nsupdate</code> timeout handling and update the <code>-t</code> option's documentation. [GL #3674]
6138.	[doc]	Fix the DF-flag documentation on the outgoing UDP packets. [GL #3710]
6136.	[cleanup]	Remove the <code>isc_fsaccess</code> API in favor of creating temporary file first and atomically replace the key with non-truncated content. [GL #3982]
6132.	[doc]	Remove a dead link in the DNSSEC guide. [GL #3967]
6129.	[cleanup]	Value stored to 'source' during its initialization is never read. [GL #3965]
6128.	[bug]	Fix an omission in an earlier commit to avoid a race between the ' <code>dns__catz_update_cb()</code> ' and ' <code>dns_catz_dbupdate_callback()</code> ' functions. [GL #3968]
6126.	[cleanup]	Deprecate zone type "delegation-only" and the

(continues on next page)

(continued from previous page)

		"delegation-only" and "root-delegation-only" options. [GL #3953]
6125.	[bug]	Hold a catz reference while the update process is running, so that the catalog zone is not destroyed during shutdown until the update process is finished or properly canceled by the activated 'shuttingdown' flag. [GL #3955]
6124.	[bug]	When changing from a NSEC3 capable DNSSEC algorithm to an NSEC3 incapable DNSSEC algorithm using KASP the zone could sometimes be incompletely signed. [GL #3937]
6121.	[bug]	Fix BIND and dig zone transfer hanging when downloading large zones over TLS from a primary server, especially over unstable connections. [GL #3867]

		--- 9.18.13 released ---
6120.	[bug]	Use two pairs of dns_db_t and dns_dbversion_t in a catalog zone structure to avoid a race between the dns__catz_update_cb() and dns_catz_dbupdate_callback() functions. [GL #3907]
6119.	[bug]	Make sure to revert the reconfigured zones to the previous version of the view, when the new view reconfiguration fails during the configuration of one of the configured zones. [GL #3911]
6116.	[bug]	Fix error path cleanup issues in dns_catz_new_zones() and dns_catz_new_zone() functions. [GL #3900]
6115.	[bug]	Unregister db update notify callback before detaching from the previous db inside the catz update notify callback. [GL #3777]
6114.	[func]	Run the catalog zone update process on the offload threads. [GL #3881]
6113.	[func]	Add shutdown signaling for catalog zones. [GL !7571]
6112.	[func]	Add reference count tracing for dns_catz_zone_t and dns_catz_zones_t. [GL !7570]
6105.	[bug]	Detach 'rpzs' and 'catzs' from the previous view in configure_rpz() and configure_catz(), respectively, just after attaching it to the new view. [GL #3880]
6098.	[test]	Don't test HMAC-MD5 when not supported by libcrypto. [GL #3871]
6096.	[bug]	Fix RPZ reference counting error on shutdown in

(continues on next page)

(continued from previous page)

		dns__rpz_timer_cb(). [GL #3866]
6095.	[test]	Test various 'islands of trust' configurations when using managed keys. [GL #3662]
6094.	[bug]	Building against (or running with) libuv versions 1.35.0 and 1.36.0 is now a fatal error. The rules for mixing and matching compile-time and run-time libuv versions have been tightened for libuv versions between 1.35.0 and 1.40.0. [GL #3840]
6092.	[bug]	dnssec-cds failed to cleanup properly. [GL #3831]
6089.	[bug]	Source ports configured for query-source, transfer-source, etc, were being ignored. (This feature is deprecated, but it is not yet removed, so the bug still needed fixing.) [GL #3790]

		--- 9.18.12 released ---
6083.	[bug]	Fix DNSRPS-enabled builds as they were inadvertently broken by change 6042. [GL #3827]
6082.	[test]	fuzz/dns_message_checksigs leaked memory when shutting down. [GL #3828]
6081.	[bug]	Handle primary server address lookup failures in nsupdate more gracefully. [GL #3830]
6080.	[bug]	'named -V' leaked memory. [GL #3829]
6079.	[bug]	Force set the DS state after a 'rndc dnssec -checkds' command. [GL #3822]
6075.	[bug]	Add missing node lock when setting node->wild in add_wildcard_magic. [GL #3799]
6074.	[func]	Refactor the isc_nm_xfr_allowed() function to return isc_result_t instead of boolean. [GL #3808]
6073.	[bug]	Set RD=1 on DS requests to parental-agents. [GL #3783]
6072.	[bug]	Avoid the OpenSSL lock contention when initializing Message Digest Contexts by using explicit algorithm fetching, initializing static contexts for every supported algorithms, and initializing the new context by copying the static copy. [GL #3795]
6071.	[func]	The use of "port" when configuring query-source, transfer-source, notify-source and parental-source addresses has been deprecated, along with the use-v[46]-udp-ports and avoid-v[46]-udp-ports

(continues on next page)

(continued from previous page)

		options. A warning will be logged when these options are used. In a future release, they will be removed. [GL #3781]
6069.	[bug]	Detach from the view in zone_shutdown() to release the memory held by the dead view early. [GL #3801]
6068.	[bug]	Downloading a zone via TLS from a server which does not negotiate "dot" ALPN token could crash BIND on shutdown. That has been fixed. [GL #3767]
6057.	[bug]	Fix shutdown and error path bugs in the rpz unit. [GL #3735]
5850.	[func]	Run the RPZ update process on the offload threads. [GL #3190]

		--- 9.18.11 released ---
6067.	[security]	Fix serve-stale crash when recursive clients soft quota is reached. (CVE-2022-3924) [GL #3619]
6066.	[security]	Handle RRSIG lookups when serve-stale is active. (CVE-2022-3736) [GL #3622]
6064.	[security]	An UPDATE message flood could cause named to exhaust all available memory. This flaw was addressed by adding a new "update-quota" statement that controls the number of simultaneous UPDATE messages that can be processed or forwarded. The default is 100. A stats counter has been added to record events when the update quota is exceeded, and the XML and JSON statistics version numbers have been updated. (CVE-2022-3094) [GL #3523]
6062.	[func]	The DSCP implementation, which has been nonfunctional for some time, is now marked as obsolete and the implementation has been removed. Configuring DSCP values in named.conf has no effect, and a warning will be logged that the feature should no longer be used. [GL #3773]
6061.	[bug]	Fix unexpected "Prohibited" extended DNS error on allow-recursion. [GL #3743]
6060.	[bug]	Fix a use-after-free bug in dns_zonemgr_releasezone() by detaching from the zone manager outside of the write lock. [GL #3768]
6059.	[bug]	In some serve stale scenarios, like when following an expired CNAME record, named could return SERVFAIL if the

(continues on next page)

(continued from previous page)

		previous request wasn't successful. Consider non-stale data when in serve-stale mode. [GL #3678]
6058.	[bug]	Prevent named from crashing when "rndc delzone" attempts to delete a zone added by a catalog zone. [GL #3745]
6053.	[bug]	Fix an ADB quota management bug in resolver. [GL #3752]
6051.	[bug]	Improve thread safety in the dns_dispatch unit. [GL #3178] [GL #3636]
6050.	[bug]	Changes to the RPZ response-policy min-update-interval and add-soa options now take effect as expected when named is reconfigured. [GL #3740]
6049.	[bug]	Exclude ABD hashtables from the ADB memory overmem checks and don't clean ADB names and ADB entries used in the last 10 seconds (ADB_CACHE_MINIMUM). [GL #3739]
6048.	[bug]	Fix a log message error in dns_catz_update_from_db(), where serials with values of 2^31 or larger were logged incorrectly as negative numbers. [GL #3742]
6047.	[bug]	Try the next server instead of trying the same server again on an outgoing query timeout. [GL #3637]
6046.	[bug]	TLS session resumption might lead to handshake failures when client certificates are used for authentication (Mutual TLS). This has been fixed. [GL #3725]
6045.	[cleanup]	The list of supported DNSSEC algorithms changed log level from "warning" to "notice" to match named's other startup messages. [GL !7217]
6044.	[bug]	There was an "RSASHA236" typo in a log message. [GL !7206]
5845.	[bug]	Refactor the timer to keep track of posted events as to use isc_task_purgeevent() instead of using isc_task_purgerange(). The isc_task_purgeevent() has been refactored to purge a single event instead of walking through the list of posted events. [GL #3252]
5830.	[func]	Implement incremental resizing of isc_ht hash tables to perform the rehashing gradually. The catalog zone implementation has been optimized to work with hundreds of thousands of member zones. [GL #3212] [GL #3744]

```

--- 9.18.10 released ---

6043.  [bug]          The key file IO locks objects would never get
                        deleted from the hashtable due to off-by-one error.
                        [GL #3727]

6042.  [bug]          ANY responses could sometimes have the wrong TTL.
                        [GL #3613]

6040.  [bug]          Speed up the named shutdown time by explicitly
                        canceling all recursing ns_client objects for
                        each ns_clientmgr. [GL #3183]

6039.  [bug]          Removing a catalog zone from catalog-zones without
                        also removing the referenced zone could leave a
                        dangling pointer. [GL #3683]

6036.  [bug]          nslookup and host were not honoring the selected port
                        in TCP mode. [GL #3721]

6034.  [func]        Deprecate alt-transfer-source, alt-transfer-source-v6
                        and use-alt-transfer-source. [GL #3694]

6031.  [bug]          Move the "final reference detached" log message
                        from dns_zone unit to the DEBUG(1) log level.
                        [GL #3707]

6027.  [bug]          Fix assertion failure in isc_http API used by
                        statschannel if the read callback would be called
                        on HTTP request that has been already closed.
                        [GL #3693]

6026.  [cleanup]     Deduplicate time unit conversion factors.
                        [GL !7033]

6025.  [bug]          Copy TLS identifier when setting up primaries for
                        catalog member zones. [GL #3638]

6024.  [func]        Deprecate 'auto-dnssec'. [GL #3667]

6022.  [performance] The decompression implementation in dns_name_fromwire()
                        is now smaller and faster. [GL #3655]

6021.  [bug]          Use the current domain name when checking answers from
                        a dual-stack-server. [GL #3607]

6020.  [bug]          Ensure 'named-checkconf -z' respects the check-wildcard
                        option when loading a zone. [GL #1905]

6019.  [func]        Deprecate `coresize`, `datasize`, `files`, and
                        `stacksize` named.conf options. [GL #3676]

```

(continues on next page)

(continued from previous page)

6017.	[bug]	The view's zone table was not locked when it should have been leading to race conditions when external extensions that manipulate the zone table where in use. [GL #3468]
6015.	[bug]	Some browsers (Firefox) send more than 10 HTTP headers. Bump the number of allowed HTTP headers to 100. [GL #3670]
5902.	[func]	NXDOMAIN cache records are no longer retained in the cache after expiry, even when serve-stale is in use. [GL #3386]

--- 9.18.9 released ---		
6013.	[bug]	Fix a crash that could happen when you change a dnssec-policy zone with NSEC3 to start using inline-signing. [GL #3591]
6009.	[bug]	Don't trust a placeholder KEYDATA from the managed-keys zone by adding it into secroots. [GL #2895]
6008.	[bug]	Fixed a race condition that could cause a crash in dns_zone_synckeyzone(). [GL #3617]
6007.	[cleanup]	Don't enforce the jemalloc use on NetBSD. [GL #3634]
6003.	[bug]	Fix an inheritance bug when setting the port on remote servers in configuration. [GL #3627]
6002.	[bug]	Fix a resolver prefetch bug when the record's TTL value is equal to the configured prefetch eligibility value, but the record was erroneously not treated as eligible for prefetching. [GL #3603]
6001.	[bug]	Always call dns_adb_endudpfetch() after calling dns_adb_beginudpfetch() for UDP queries in resolver.c, in order to adjust back the quota. [GL #3598]
6000.	[bug]	Fix a startup issue on Solaris systems with many (reportedly > 510) CPUs. Thanks to Stacey Marshall from Oracle for deep investigation of the problem. [GL #3563]
5999.	[bug]	rpz-ip rules could be ineffective in some scenarios with CD=1 queries. [GL #3247]
5998.	[bug]	The RecursClients statistics counter could overflow in certain resolution scenarios. [GL #3584]
5997.	[cleanup]	Less ceremonial UNEXPECTED_ERROR() and FATAL_ERROR() reporting macros. [GL !6914]

(continues on next page)

(continued from previous page)

5996.	[bug]	Fix a couple of bugs in <code>cfg_print_duration()</code> , which could result in generating incomplete duration values when printing the configuration using <code>named-checkconf</code> . [GL !6880]
5994.	[func]	Refactor the <code>isc_httpd</code> implementation used in the statistics channel. [GL !6879]

--- 9.18.8 released ---		
5991.	[protocol]	Add support for parsing and validating "dohpath" to SVCB. [GL #3544]
5990.	[test]	<code>fuzz/dns_message_checksigs</code> now creates the key directory it uses when testing in <code>/tmp</code> at run time. [GL #3569]
5988.	[bug]	Some out of memory conditions in <code>opensslrsa_link.c</code> could lead to memory leaks. [GL #3551]
5984.	[func]	' <code>named -V</code> ' now reports the list of supported DNSSEC/DS/HMAC algorithms and the supported TKEY modes. [GL #3541]
5983.	[bug]	Changing just the TSIG key names for primaries in catalog zones' member zones was not effective. [GL #3557]
5982.	[func]	Extend <code>dig</code> to allow requests to be signed using <code>SIG(0)</code> as well as providing a mechanism to specify the signing time. [GL !5923]
5981.	[test]	Add <code>dns_message_checksigs</code> fuzzer to check messages signed using TSIG or <code>SIG(0)</code> . [GL !5923]
5978.	[port]	The ability to use <code>pkcs11</code> via <code>engine_pkcs11</code> has been restored, by only using deprecated APIs in OpenSSL 3.0.0. BIND needs to be compiled with ' <code>-DOPENSSL_API_COMPAT=10100</code> ' specified in the CFLAGS at compile time. [GL !6711]
5973.	[bug]	Fixed a possible invalid detach in UPDATE processing. [GL #3522]
5972.	[bug]	Gracefully handle when the statschannel HTTP connection gets cancelled during sending data back to the client. [GL #3542]
5970.	[func]	Log the reason why a query was refused. [GL !6669]
5967.	[cleanup]	Flagged the "random-device" option (which was already nonoperational) as obsolete; configuring it will generate a warning. [GL #3399]

(continues on next page)

(continued from previous page)

5963. [bug] Ensure struct named\_server is properly initialized.  
[GL #6531]

--- 9.18.7 released ---

5962. [security] Fix memory leak in EdDSA verify processing.  
(CVE-2022-38178) [GL #3487]

5960. [security] Fix serve-stale crash that could happen when  
stale-answer-client-timeout was set to 0 and there was  
a stale CNAME in the cache for an incoming query.  
(CVE-2022-3080) [GL #3517]

5959. [security] Fix memory leaks in the DH code when using OpenSSL 3.0.0  
and later versions. The openssldh\_compare(),  
openssldh\_paramcompare(), and openssldh\_todns()  
functions were affected. (CVE-2022-2906) [GL #3491]

5958. [security] When an HTTP connection was reused to get  
statistics from the stats channel, and zlib  
compression was in use, each successive  
response sent larger and larger blocks of memory,  
potentially reading past the end of the allocated  
buffer. (CVE-2022-2881) [GL #3493]

5957. [security] Prevent excessive resource use while processing large  
delegations. (CVE-2022-2795) [GL #3394]

5956. [func] Make RRL code treat all QNAMES that are subject to  
wildcard processing within a given zone as the same  
name. [GL #3459]

5955. [port] The libxml2 library has deprecated the usage of  
xmlInitThreads() and xmlCleanupThreads() functions. Use  
xmlInitParser() and xmlCleanupParser() instead.  
[GL #3518]

5954. [func] Fallback to IDNA2003 processing in dig when IDNA2008  
conversion fails. [GL #3485]

5953. [bug] Fix a crash on shutdown in delete\_trace\_entry(). Add  
mctx attach/detach pair to make sure that the memory  
context used by a memory pool is not destroyed before  
the memory pool itself. [GL #3515]

5952. [bug] Use quotes around address strings in YAML output.  
[GL #3511]

5951. [bug] In some cases, the dnstap query\_message field was  
erroneously set when logging response messages.  
[GL #3501]

(continues on next page)

(continued from previous page)

5948.	[bug]	Fix nsec3.c:dns_nsec3_activex() function, add a missing dns_db_detachnode() call. [GL #3500]
5947.	[func]	Change dnssec-policy to allow graceful transition from an NSEC only zone to NSEC3. [GL #3486]
5946.	[bug]	Fix statistics channel's handling of multiple HTTP requests in a single connection which have non-empty request bodies. [GL #3463]
5945.	[bug]	If parsing /etc/bind.key failed, delv could assert when trying to parse the built in trust anchors as the parser hadn't been reset. [GL !6468]
5944.	[bug]	Fix +http-plain-get and +http-plain-post options support in dig. Thanks to Marco Davids at SIDN for reporting the problem. [GL !6672]
5942.	[bug]	Fix tkey.c:buildquery() function's error handling by adding the missing cleanup code. [GL #3492]
5941.	[func]	Zones with dnssec-policy now require dynamic DNS or inline-siging to be configured explicitly. [GL #3381]
5938.	[bug]	An integer type overflow could cause an assertion failure when freeing memory. [GL #3483]
5936.	[bug]	Don't enable serve-stale for lookups that error because it is a duplicate query or a query that would be dropped. [GL #2982]
5935.	[bug]	Fix DiG lookup reference counting bug, which could be observed in NSSEARCH mode. [GL #3478]

--- 9.18.6 released ---

5934.	[func]	Improve fetches-per-zone fetch limit logging to log the final allowed and spilled values of the fetch counters before the counter object gets destroyed. [GL #3461]
5933.	[port]	Automatically disable RSASHA1 and NSEC3RSASHA1 in named on Fedorda 33, Oracle Linux 9 and RHEL9 when they are disabled by the security policy. [GL #3469]
5932.	[bug]	Fix rndc dumpdb -expired and always include expired RRsets, not just for RBTDB_VIRTUAL time window. [GL #3462]
5931.	[bug]	Fix DiG query error handling robustness in NSSEARCH mode by making sure that udp_ready(), tcp_connected(),

(continues on next page)

(continued from previous page)

		and send_done() callbacks start the next query in chain even if there is some kind of error with the previous query. [GL #3419]
5930.	[bug]	Fix DiG query retry and fail-over bug in UDP mode. Also simplify the overall retry and fail-over logic to make it behave predictably, and always respect the documented +retry/+tries count set by a command-line option (or use the default values of 2 or 3 respectively). [GL #3407]
5929.	[bug]	The "max-zone-ttl" option in "dnssec-policy" was not fully effective; it was used for timing key rollovers but did not actually place an upper limit on TTLs when loading a zone. This has been corrected, and the documentation has been clarified to indicate that the old "max-zone-ttl" zone option is now ignored when "dnssec-policy" is in use. [GL #2918]
5927.	[bug]	A race was possible in dns_dispatch_connect() that could trigger an assertion failure if two threads called it near-simultaneously. [GL #3456]
5926.	[func]	Handle transient TCP connect() EADDRINUSE failures on FreeBSD (and possibly other BSDs) by trying three times before giving up. [GL #3451]
5925.	[bug]	With a forwarder configured for all queries, resolution failures encountered during DS chasing could trigger assertion failures due to a logic bug in resume_dslookup() that caused it to call dns_resolver_createfetch() with an invalid name. [GL #3439]
5924.	[func]	When it's necessary to use AXFR to respond to an IXFR request, a message explaining the reason is now logged at level info. [GL #2683]
5923.	[bug]	Fix inheritance for dnssec-policy when checking for inline-signing. [GL #3438]
5922.	[bug]	Forwarding of UPDATE message could fail with the introduction of netmgr. This has been fixed. [GL #3389]
5921.	[test]	Convert system tests to use a default DNSKEY algorithm where the test is not DNSKEY algorithm specific. [GL #3440]

--- 9.18.5 released ---

5917.	[bug]	Update ifconfig.sh script as is miscomputed interface
-------	-------	---

(continues on next page)

(continued from previous page)

		identifiers when destroying interfaces. [GL #3061]
5916.	[bug]	When resolving a name, don't give up immediately if an authoritative server returns FORMERR; try the other servers first. [GL #3152]
5915.	[bug]	Detect missing closing brace (}) and computational overflows in \$GENERATE directives. [GL #3429]
5914.	[bug]	When synth-from-dnssec generated a response using records from a higher zone, it could unexpectedly prove non-existence of records in a subordinate grafted-on namespace. [GL #3402]
5911.	[bug]	Update HTTP listener settings on reconfiguration. [GL #3415]
5910.	[cleanup]	Move built-in dnssec-policies into the defaultconf. These are now printed with 'named -C'. [GL !6467]
5909.	[bug]	The server-side destination port was missing from dnstap captures of client traffic. [GL #3309]
5908.	[bug]	Fix race conditions in route_connected(). [GL #3401]
5907.	[bug]	Fix a crash in dig NS search mode when one of the NS server queries fail. [GL #3207]
5905.	[bug]	When the TCP connection would be closed/reset between the connect/accept and the read, the uv_read_start() return value would be unexpected and cause an assertion failure. [GL #3400]
5904.	[func]	Changed dnssec-signzone -H default to 0 additional NSEC3 iterations. [GL #3395]
5903.	[bug]	When named checks that the OPCODE in a response matches that of the request, if there is a mismatch named logs an error. Some of those error messages incorrectly used RCODE instead of OPCODE to lookup the mnemonic. This has been corrected. [GL !6420]
5901.	[bug]	When processing a catalog zone member zone make sure that there is no configured pre-existing forward-only forward zone with that name. [GL #2506]

--- 9.18.4 released ---

5899.	[func]	Don't try to process DNSSEC-related and ZONEMD records in catz. [GL #3380]
5896.	[func]	Add some more dnssec-policy checks to detect weird

(continues on next page)

(continued from previous page)

		policies. [GL #1611]
5895.	[test]	Add new set of unit test macros and move the unit tests under single namespace in /tests/. [GL !6243]
5893.	[func]	Add TLS session resumption support to the client-side TLS code. [GL !6274]
5891.	[func]	Key timing options for `dnssec-settime` and related utilities now accept "UNSET" times as printed by `dnssec-settime -p`. [GL #3361]
5890.	[bug]	When the fetches-per-server quota was adjusted because of an authoritative server timing out more or less frequently, it was incorrectly set to 1 rather than the intended value. This has been fixed. [GL #3327]
5888.	[bug]	Only write key files if the dnssec-policy keymgr has changed the metadata. [GL #3302]
5837.	[func]	Key timing options for `dnssec-keygen` and `dnssec-settime` now accept times as printed by `dnssec-settime -p`. [GL !2947]

		--- 9.18.3 released ---
5886.	[security]	Fix a crash in DNS-over-HTTPS (DoH) code caused by premature TLS stream socket object deletion. (CVE-2022-1183) [GL #3216]
5885.	[bug]	RPZ NSIP and NSDNAME rule processing didn't handle stub and static-stub zones at or above the query name. This has now been addressed. [GL #3232]
5882.	[contrib]	Avoid name space collision in dlz modules by prefixing functions with 'dlz_'. [GL !5778]
5880.	[func]	Add new named command-line option -C to print built-in defaults. [GL #1326]
5879.	[contrib]	dlz: Add FALLTHROUGH and UNREACHABLE macros. [GL #3306]
5877.	[func]	Introduce the concept of broken catalog zones described in the DNS catalog zones draft version 5 document. [GL #3224]
5876.	[func]	Add DNS Extended Errors when stale answers are returned from cache. [GL #2267]
5875.	[bug]	Fixed a deadlock that could occur if an rndc connection arrived during the shutdown of network

(continues on next page)

(continued from previous page)

		interfaces. [GL #3272]
5873.	[bug]	Refactor the <code>fctx_done()</code> function to set <code>fctx</code> to <code>NULL</code> after detaching, so that reference counting errors will be easier to avoid. [GL #2969]
5872.	[bug]	<code>udp_recv()</code> in <code>dispatch</code> could trigger an <code>INSIST</code> when the callback's result indicated success but the response was canceled in the meantime. [GL #3300]
5866.	[bug]	Work around a <code>jemalloc</code> quirk which could trigger an out-of-memory condition in <code>named</code> over time. [GL #3287]
5863.	[bug]	If there was a pending negative cache DS entry, validations depending upon it could fail. [GL #3279]
5862.	[bug]	<code>dig</code> returned a 0 exit status on UDP connection failure. [GL #3235]
5861.	[func]	Implement support for catalog zones change of ownership ( <code>coo</code> ) mechanism described in the DNS catalog zones draft version 5 document. [GL #3223]
5860.	[func]	Implement support for catalog zones options new syntax based on catalog zones custom properties with <code>"ext"</code> suffix described in the DNS catalog zones draft version 5 document. [GL #3222]
5859.	[bug]	Fix an assertion failure when using <code>dig</code> with <code>+nssearch</code> and <code>+tcp</code> options by starting the next query in the <code>send_done()</code> callback (like in the UDP mode) instead of doing that recursively in <code>start_tcp()</code> . Also ensure that queries interrupted while connecting are detached properly. [GL #3144]
5858.	[bug]	Don't remove <code>CDS/CDNSKEY DELETE</code> records on zone sign when using <code>'auto-dnssec maintain;'</code> . [GL #2931]
5854.	[func]	Implement reference counting for TLS contexts and allow reloading of TLS certificates on reconfiguration without destroying the underlying TCP listener sockets for TLS-based DNS transports. [GL #3122]
5849.	[cleanup]	Remove use of exclusive mode in <code>ns_interfacemgr</code> in favor of <code>rwlocked</code> access to <code>localhost</code> and <code>localnets</code> members of <code>dns_aclenv_t</code> structure. [GL #3229]
5842.	[cleanup]	Remove the task exclusive mode use in <code>ns_clientmgr</code> . [GL #3230]
5839.	[func]	Add support for remote TLS certificates verification, both to <code>BIND</code> and <code>dig</code> , making it possible

(continues on next page)

(continued from previous page)

to implement Strict and Mutual TLS authentication,  
as described in RFC 9103, Section 9.3. [GL #3163]

--- 9.18.2 released ---

- 5856. [bug] The "starting maxtime timer" message related to outgoing zone transfers was incorrectly logged at the ERROR level instead of DEBUG(1). [GL #3208]
- 5855. [bug] Ensure that zone maintenance queries have a retry limit. [GL #3242]
- 5853. [bug] When using both the `+qr` and `+y` options `dig` could crash if the connection to the first server was not successful. [GL #3244]
- 5852. [func] Add new "reuseport" option to enable/disable load balancing of sockets. [GL #3249]
- 5848. [bug] dig could hang in some cases involving multiple servers in a lookup, when a request fails and the next one refuses to start for some reason, for example if it was an IPv4 mapped IPv6 address. [GL #3248]
- 5844. [bug] dig +nssearch was hanging until manually interrupted. [GL #3145]
- 5843. [bug] When an UPDATE targets a zone that is not configured, the requested zone name is now logged in the "not authoritative" error message, so that it is easier to track down problematic update clients. [GL #3209]
- 5838. [cleanup] When modifying a member zone in a catalog zone, and it is detected that the zone exists and was not created by the current catalog zone, distinguish the two cases when the zone was not added by a catalog zone at all, and when the zone was added by a different catalog zone, and log a warning message accordingly. [GL #3221]
- 5836. [bug] Quote the dns64 prefix in error messages that complain about problems with it, to avoid confusion with the following dns64 ACLs. [GL #3210]
- 5834. [cleanup] C99 variable-length arrays are difficult to use safely, so avoid them except in test code. [GL #3201]
- 5833. [bug] When encountering socket error while trying to initiate a TCP connection to a server, dig could hang indefinitely, when there were more servers to try. [GL #3205]
- 5832. [bug] When timing-out or having other types of socket errors

(continues on next page)

(continued from previous page)

		during a query, dig wasn't trying to perform the lookup using other servers, in case they exist. [GL #3128]
5831.	[bug]	When resending a UDP request in the result of a timeout, the <code>recv_done()</code> function in <code>dighost.c</code> was prepending the new query into the <code>lolookup</code> 's queries list instead of inserting, which could cause an assertion failure when the resent query's result was <code>SERVFAIL</code> . [GL #3020]
5828.	[bug]	Replace single TCP write timer with per-TCP write timers. [GL #3200]
5825.	[func]	Set the minimum MTU on UDPv6 and TCPv6 sockets and limit TCP maximum segment size ( <code>TCP_MAXSEG</code> ) to (1220) for both TCPv4 and TCPv6 sockets. [GL #2201]
5824.	[bug]	Invalid <code>dnssec-policy</code> definitions were being accepted where the defined keys did not cover both KSK and ZSK roles for a given algorithm. This is now checked for and the <code>dnssec-policy</code> is rejected if both roles are not present for all algorithms in use. [GL #3142]
5823.	[func]	Replace hazard pointers based lock-free list with locked-list based queue that's simpler and has no or little performance impact. [GL #3180]
5822.	[bug]	When calling <code>dns_dispatch_send()</code> , attach/detach <code>dns_request_t</code> object as the read callback could be called before send callback dereferencing <code>dns_request_t</code> object too early. [GL #3105]
5821.	[bug]	Fix query context management issues in the TCP part of dig. [GL #3184]

--- 9.18.1 released ---		
5820.	[security]	An assertion could occur in <code>resume_dslookup()</code> if the fetch had been shut down earlier. (CVE-2022-0667) [GL #3129]
5819.	[security]	Lookups involving a <code>DNAME</code> could trigger an <code>INSIST</code> when " <code>synth-from-dnssec</code> " was enabled. (CVE-2022-0635) [GL #3158]
5818.	[security]	A synchronous call to <code>closehandle_cb()</code> caused <code>isc_nm_process_sock_buffer()</code> to be called recursively, which in turn left TCP connections hanging in the <code>CLOSE_WAIT</code> state blocking indefinitely when out-of-order processing was disabled. (CVE-2022-0396) [GL #3112]
5817.	[security]	The rules for acceptance of records into the cache

(continues on next page)

(continued from previous page)

		have been tightened to prevent the possibility of poisoning if forwarders send records outside the configured bailiwick. (CVE-2021-25220) [GL #2950]
5816.	[bug]	Make BIND compile with LibreSSL 3.5.0, as it was using not very accurate pre-processor checks for using shims. [GL #3172]
5815.	[bug]	If an oversized key name of a specific length was used in the text form of an HTTP or SVBC record, an INSIST could be triggered when parsing it. [GL #3175]
5814.	[bug]	The RecursClients statistics counter could underflow in certain resolution scenarios. [GL #3147]
5812.	[func]	Drop the artificial limit on the number of queries processed in a single TCP read callback. [GL #3141]
5811.	[bug]	Reimplement the maximum and idle timeouts for outgoing zone transfers. [GL #1897]
5809.	[bug]	Reset client TCP connection when data received cannot be parsed as a valid DNS request. [GL #3149]
5808.	[bug]	Certain TCP failures were not caught and handled correctly by the dispatch manager, causing connections to time out rather than returning SERVFAIL. [GL #3133]
5807.	[bug]	Add a TCP "write" timer, and time out writing connections after the "tcp-idle-timeout" period has elapsed. [GL #3132]
5806.	[bug]	An error in checking the "blackhole" ACL could cause DNS requests sent by named to fail if the destination address or prefix was specifically excluded from the ACL. [GL #3157]
5805.	[func]	The result of each resolver priming attempt is now included in the "resolver priming query complete" log message. [GL #3139]
5804.	[func]	Add a debug log message when starting and ending the task exclusive mode. [GL #3137]
5803.	[func]	Use compile-time paths in the documentation. [GL #2717]
5802.	[test]	Add system test to test engine_pkcs11. [GL !5727]
5801.	[bug]	Log "quota reached" message when hard quota is reached when accepting a connection. [GL #3125]

(continues on next page)

(continued from previous page)

```
5800. [func]      Add ECS support to the DLZ interface. [GL #3082]
5799. [bug]      Use L1 cache-line size detected at runtime. [GL #3108]
5798. [test]     Add system test to test dnssec-keyfromlabel. [GL #3092]
5797. [bug]      A failed view configuration during a named
reconfiguration procedure could cause inconsistencies
in BIND internal structures, causing a crash or other
unexpected errors. [GL #3060]
```

--- 9.18.0 released ---

```
5796. [bug]      Ignore the invalid (<= 0) values returned
by the sysconf() check for the L1 cache line
size. [GL #3108]
5795. [bug]      rndc could crash when interrupted by a signal
before receiving a response. [GL #3080]
5794. [func]     Set the IPV6_V6ONLY on all IPv6 sockets to
restrict the IPv6 sockets to sending and
receiving IPv6 packets only. [GL #3093]
5793. [bug]      Correctly detect and enable UDP recvmmsg support
in all versions of libuv that support it. [GL #3095]
5792. [bug]      Don't schedule zone events on ISC_R_SHUTTINGDOWN
event failures. [GL #3084]
5791. [func]     Remove workaround for servers returning FORMERR
when receiving NOTIFY query with SOA record in
ANSWER section. [GL #3086]
5790. [bug]      The control channel was incorrectly looking for
ISC_R_CANCELED as a signal that the named is
shutting down. In the dispatch refactoring,
the result code returned from network manager
is now ISC_R_SHUTTINGDOWN. Change the control
channel code to use ISC_R_SHUTTINGDOWN result
code to detect named being shut down. [GL #3079]
```

--- 9.17.22 released ---

```
5789. [bug]      Allow replacing expired zone signatures with
signatures created by the KSK. [GL #3049]
5788. [bug]      An assertion could occur if a catalog zone event was
scheduled while the task manager was being shut
down. [GL #3074]
```

(continues on next page)

(continued from previous page)

- 5787. [doc] Update 'auto-dnssec' documentation, it may only be activated at zone level. [GL #3023]
- 5786. [bug] Defer detaching from zone->raw in zone\_shutdown() if the zone is in the process of being dumped to disk, to ensure that the unsigned serial number information is always written in the raw-format header of the signed version on an inline-signed zone. [GL #3071]
- 5785. [bug] named could leak memory when two dnssec-policy clauses had the same name. named failed to log this error. [GL #3085]
- 5784. [func] Implement TLS-contexts reuse. Reusing the previously created TLS context objects can reduce initialisation time for some configurations and enables TLS session resumption for incoming zone transfers over TLS (XoT). [GL #3067]
- 5783. [func] named is now able to log TLS pre-master secrets for debugging purposes. This requires setting the SSLKEYLOGFILE environment variable appropriately. [GL #2723]
- 5782. [func] Use ECDSA P-256 instead of a 4096-bit RSA when generating ephemeral key and certificate for the 'tls ephemeral' configuration. [GL #2264]
- 5781. [bug] Make BIND work with OpenSSL 3.0.1 as it is now enforcing minimum buffer lengths in EVP\_MAC\_final and hence EVP\_DigestSignFinal. rndc and TSIG at a minimum were broken by this change. [GL #3057]
- 5780. [bug] The Linux kernel may send netlink messages indicating that network interfaces have changed when they have not. This caused frequent unnecessary re-scans of the interfaces. Netlink messages now only trigger re-scanning if a new address is seen or an existing address is removed. [GL #3055]
- 5779. [test] Drop cppcheck suppressions and workarounds. [GL #2886]
- 5778. [bug] Destroyed TLS contexts could have been used after a reconfiguration, making BIND unable to serve queries over TLS and HTTPS. [GL #3053]
- 5777. [bug] TCP connections could hang after receiving non-matching responses. [GL #3042]
- 5776. [bug] Add a missing isc\_condition\_destroy() for nmsocket condition variable and add missing isc\_mutex\_destroy()

(continues on next page)

(continued from previous page)

for nmworker lock. [GL #3051]

--- 9.17.21 released ---

- 5775. [bug] Added a timer in the resolver to kill fetches that have deadlocked as a result of dependency loops with the ADB or the validator. This condition is now logged with the message "shut down hung fetch while resolving '<name>/<type>'". [GL #3040]
- 5774. [func] Restore NSEC Aggressive Cache ("synth-from-dnssec") as active by default. It is limited to NSEC only and by default ignores NSEC records with next name in form \000.domain. [GL #1265]
- 5773. [func] Change the message when accepting TCP connection has failed to say "Accepting TCP connection failed" and change the log level for ISC\_R\_NOTCONNECTED, ISC\_R\_QUOTA and ISC\_R\_SOFTQUOTA results codes from ERROR to INFO. [GL #2700]
- 5772. [bug] The resolver could hang on shutdown due to dispatch resources not being cleaned up when a TCP connection was reset. [GL #3026]
- 5771. [bug] Use idn2 UseSTD3ASCIIRules=false to disable additional unicode validity checks because enabling the additional checks would break valid domain names that contains non-alphanumerical characters such as underscore character (\_) or wildcard (\*). This reverts change [GL #5738] from the previous release. [GL #1610]
- 5770. [func] BIND could abort on startup on systems using old OpenSSL versions when 'protocols' option is used inside a 'tls' statement. [GL #5602]
- 5769. [func] Added support for client-side 'tls' parameters when doing incoming zone transfers via XoT. [GL #5602]
- 5768. [bug] dnssec-dsfromkey failed to omit revoked keys. [GL #853]
- 5767. [func] Extend allow-transfer option with 'port' and 'transport' options to restrict zone transfers to a specific port and DNS transport protocol. [GL #2776]
- 5766. [func] Unused 'tls' clause options 'ca-file' and 'hostname' were disabled. [GL #5600]
- 5765. [bug] Fix a bug in DoH implementation making 'dig' abort when ALPN negotiation fails. [GL #3022]

(continues on next page)

(continued from previous page)

5764.	[bug]	dns_sdlez_putrr failed to process some valid resource records. [GL #3021]
5763.	[bug]	Fix a bug in DoT code leading to an abort when a zone transfer ends with an unexpected DNS message. [GL #3004]
5762.	[bug]	Fix a "named" crash related to removing and restoring a `catalog-zone` entry in the configuration file and running `rndc reconfig`. [GL #1608]
5761.	[bug]	OpenSSL 3.0.0 support could fail to correctly read ECDSA private keys leading to incorrect signatures being generated. [GL #3014]
5760.	[bug]	Prevent a possible use-after-free error in resolver. [GL #3018]
5759.	[func]	Set Extended DNS Error Code 18 - Prohibited if query access is denied to the specific client. [GL #1836]
5758.	[bug]	mdig now honors the operating system's preferred ephemeral port range. [GL #2374]
5757.	[test]	Replace sed in nsupdate system test with awk to construct the nsupdate command. The sed expression was not reliably changing the ttl. [GL #3003]
5756.	[func]	Assign HTTP freshness lifetime to responses sent via DNS-over-HTTPS, according to the recommendations given in RFC 8484. [GL #2854]

--- 9.17.20 released ---

5755.	[bug]	The statistics channel wasn't correctly handling multiple HTTP requests, or pipelined or truncated requests. [GL #2973]
5754.	[bug]	"tls" statements may omit "key-file" and "cert-file", but if either one is specified, then both must be. [GL #2986]
5753.	[placeholder]	
5752.	[bug]	Fix an assertion failure caused by missing member zones during a reload of a catalog zone. [GL #2308]
5751.	[port]	Add support for OpenSSL 3.0.0. OpenSSL 3.0.0 deprecated 'engine' support. If OpenSSL 3.0.0 has been built without support for deprecated functionality pkcs11 via engine_pkcs11 is no longer available. [GL #2843]

(continues on next page)

(continued from previous page)

- 5750. [bug] Fix a bug when comparing two RSA keys. There was a typo which caused the "p" prime factors to not being compared. [GL #2972]
- 5749. [bug] Handle duplicate references to the same catalog zone gracefully. [GL #2916]
- 5748. [func] Update "nsec3param" defaults to iterations 0, salt length 0. [GL #2956]
- 5747. [func] Update rndc serve-stale status output to be less confusing. [GL #2742]
- 5746. [bug] A lame server delegation could lead to a loop in which a resolver fetch depends on an ADB find which depends on the same resolver fetch. Previously, this would cause the fetch to hang until timing out, but after change #5730 it would hang forever. The condition is now detected and avoided. [GL #2927]
- 5745. [bug] Fetch context objects now use attach/detach semantics to make it easier to find and debug reference-counting errors, and several such errors have been fixed. [GL #2953]
- 5744. [func] The network manager is now used for netlink sockets to monitor network interface changes. This was the last remaining use of the old isc\_socket and isc\_socketmgr APIs, so they have now been removed. The "named -S" argument and the "reserved-sockets" option in named.conf have no function now, and are deprecated. "socketmgr" statistics are no longer reported in the statistics channel. [GL #2926]
- 5743. [func] Add finer-grained "update-policy" rules, "krb5-subdomain-self-rhs" and "ms-subdomain-self-rhs", which restrict SRV and PTR record changes, allowing only records whose content matches the machine name embedded in the Kerberos principal making the change. [GL #481]
- 5742. [func] ISC\_LIKELY() and ISC\_UNLIKELY() macros have been removed. [GL #2952]
- 5741. [bug] Log files with "timestamp" suffixes could be left in place after rolling, even if the number of preserved log files exceeded the configured "versions" limit. [GL #828]
- 5740. [func] Implement incremental resizing of RBT hash table to perform the rehashing gradually. [GL #2941]

(continues on next page)

(continued from previous page)

5739.	[func]	Change default of 'dnssec-dnskey-kskonly' to 'yes'. [GL #1316]
5738.	[bug]	Enable idn2 UseSTD3ASCIIRules=true to implement additional unicode validity checks. [GL #1610]
5737.	[bug]	Address Coverity warning in lib/dns/dnssec.c. [GL #2935]

--- 9.17.19 released ---

5736.	[security]	The "lame-ttl" option is now forcibly set to 0. This effectively disables the lame server cache, as it could previously be abused by an attacker to significantly degrade resolver performance. (CVE-2021-25219) [GL #2899]
5735.	[cleanup]	The result codes which BIND 9 uses internally are now all defined as a single list of enum values rather than as multiple sets of integers scattered around shared libraries. This prevents the need for locking in some functions operating on result codes, and makes result codes more debugger-friendly. [GL #719]
5734.	[bug]	Fix intermittent assertion failures in dig which were triggered during zone transfers. [GL #2884]
5733.	[func]	Require the "dot" Application-Layer Protocol Negotiation (ALPN) token to be selected in the TLS handshake for zone transfers over TLS (XoT), as required by RFC 9103 section 7.1. [GL #2794]
5732.	[cleanup]	Remove the dns_lib_init(), dns_lib_shutdown(), ns_lib_init(), and ns_lib_shutdown() functions, as they no longer served any useful purpose. [GL #88]
5731.	[bug]	Disallow defining "http" configuration clauses called "default" as they were silently ignored. [GL #2925]
5730.	[func]	The resolver and the request and dispatch managers have been substantially refactored, and are now based on the network manager instead of the old isc_socket API. All outgoing DNS queries and requests now use the new API; isc_socket is only used to monitor for network interface changes. [GL #2401]
5729.	[func]	Allow finer control over TLS protocol configuration by implementing new options for "tls" configuration clauses ("dhparam-file", "ciphers", "prefer-server-ciphers", "session-tickets"). These options make achieving perfect forward secrecy (PFS) possible for DNS-over-TLS (DoT)

(continues on next page)

(continued from previous page)

- and DNS-over-HTTPS (DoH). [GL #2796]
- 5728. [func] Allow specifying supported TLS protocol versions for each "tls" configuration clause. [GL #2795]
- 5727. [placeholder]
- 5726. [bug] Fix a use-after-free bug which was triggered while checking for duplicate "http" configuration clauses. [GL #2924]
- 5725. [bug] Fix an assertion failure triggered by passing an invalid HTTP path to dig. [GL #2923]
- 5724. [bug] Address a potential deadlock when checking zone content consistency. [GL #2908]
- 5723. [bug] Change 5709 broke backward compatibility for the "check-names master ..." and "check-names slave ..." options. This has been fixed. [GL #2911]
- 5722. [bug] Preserve the contents of the receive buffer for TCPDNS and TLSDNS when growing its size. [GL #2917]
- 5721. [func] A new realloc()-like function, `isc_mem_reget()`, was added to the libisc API for resizing memory chunks allocated using `isc_mem_get()`. Memory (re)allocation functions are now guaranteed to return non-NULL pointers for zero-sized allocation requests. [GL #5440]
- 5720. [contrib] Remove old-style DLZ drivers that had to be enabled at build time. [GL #2814]
- 5719. [func] Remove support for the "map" zone file format. [GL #2882]
- 5718. [bug] The "sig-signing-type" zone configuration option was processed incorrectly, causing valid configurations to be rejected. This has been fixed. [GL #2906]
- 5717. [func] The "cache-file" option, which was documented as "for testing purposes only" and not to be used, has been removed. [GL #2903]
- 5716. [placeholder]
- 5715. [func] Add a check for ports specified in "`*-source(-v6)`" options clashing with a global listening port. Such a configuration was already unsupported, but it failed silently; it is now treated as an error. [GL #2888]
- 5714. [bug] Remove the "adjust interface" mechanism which was

(continues on next page)

(continued from previous page)

		responsible for setting up listeners on interfaces when the "*-source(-v6)" address and port were the same as the "listen-on(-v6)" address and port. Such a configuration is no longer supported; under certain timing conditions, that mechanism could prevent named from listening on some TCP ports. This has been fixed. [GL #2852]
5713.	[func]	Add "primaries" as a synonym for "masters" and "default-primaries" as a synonym for "default-masters" in catalog zone configuration options. [GL #2818]
5712.	[func]	Remove native PKCS#11 support in favor of engine_pkcs11 from the OpenSC project. [GL #2691]

		--- 9.17.18 released ---
5711.	[bug]	"map" files exceeding 2GB in size failed to load due to a size comparison that incorrectly treated the file size as a signed integer. [GL #2878]
5710.	[placeholder]	
5709.	[func]	When reporting zone types in the statistics channel, the terms "primary" and "secondary" are now used instead of "master" and "slave", respectively. Enum values throughout the code have been updated to use this terminology as well. [GL #1944]
5708.	[placeholder]	
5707.	[bug]	A bug was fixed which prevented dig from querying DNS-over-HTTPS (DoH) servers via IPv6. [GL #2860]
5706.	[cleanup]	Support for external applications to register with libisc and use it has been removed. Export versions of BIND 9 libraries have not been supported for some time, but the isc_lib_register() function was still available; it has now been removed. [GL #2420]
5705.	[bug]	Change #5686 altered the internal memory structure of zone databases, but neglected to update the MAPAPI value for zone files in "map" format. This caused named to attempt to load incompatible map files, triggering an assertion failure on startup. The MAPAPI value has now been updated, so named rejects outdated files when encountering them. [GL #2872]
5704.	[bug]	Change #5317 caused the EDNS TCP Keepalive option to be ignored inadvertently in client requests. It has now been fixed and this option is handled properly again. [GL #1927]

(continues on next page)

(continued from previous page)

- 5703. [bug] Fix a crash in dig caused by closing an HTTP/2 socket associated with an unused HTTP/2 session. [GL #2858]
- 5702. [bug] Improve compatibility with DNS-over-HTTPS (DoH) clients by allowing HTTP/2 request headers in any order. [GL #2875]
- 5701. [bug] named-checkconf failed to detect syntactically invalid values of the "key" and "tls" parameters used to define members of remote server lists. [GL #2461]
- 5700. [bug] When a member zone was removed from a catalog zone, journal files for the former were not deleted. [GL #2842]
- 5699. [func] Data structures holding DNSSEC signing statistics are now grown and shrunk as necessary upon key rollover events. [GL #1721]
- 5698. [bug] When a DNSSEC-signed zone which only has a single signing key available is migrated to use KASP, that key is now treated as a Combined Signing Key (CSK). [GL #2857]
- 5697. [func] dnssec-cds now only generates SHA-2 DS records by default and avoids copying deprecated SHA-1 records from a child zone to its delegation in the parent. If the child zone does not publish SHA-2 CDS records, dnssec-cds will generate them from the CDNSKEY records. The "-a algorithm" option now affects the process of generating DS digest records from both CDS and CDNSKEY records. Thanks to Tony Finch. [GL #2871]
- 5696. [protocol] Support for HTTPS and SVCB record types has been added. [GL #1132]
- 5695. [func] Add a new dig command-line option, "+showbadcookie", which causes a BADCOOKIE response message to be displayed when it is received from the server. [GL #2319]
- 5694. [bug] Stale data in the cache could cause named to send non-minimized queries despite QNAME minimization being enabled. [GL #2665]
- 5693. [func] Restore support for reading "timeout" and "attempts" options from /etc/resolv.conf, and use their values in dig, host, and nslookup. (This was previously supported by liblwres, and was still mentioned in the man pages, but had stopped working after liblwres was deprecated in favor of libirs.) [GL #2785]

(continues on next page)

(continued from previous page)

- 5692. [bug] Fix a rare crash in DNS-over-HTTPS (DoH) code caused by detaching from an HTTP/2 session handle too early when sending data. [GL #2851]
- 5691. [bug] When a dynamic zone was made available in another view using the "in-view" statement, running "rndc freeze" always reported an "already frozen" error even though the zone was successfully frozen. [GL #2844]
- 5690. [func] dnssec-signzone now honors Predecessor and Successor metadata found in private key files: if a signature for an RRset generated by the inactive predecessor exists and does not need to be replaced, no additional signature is now created for that RRset using the successor key. This enables dnssec-signzone to gradually replace RRSIGs during a ZSK rollover. [GL #1551]

--- 9.17.17 released ---

- 5689. [security] An assertion failure occurred when named attempted to send a UDP packet that exceeded the MTU size, if Response Rate Limiting (RRL) was enabled. (CVE-2021-25218) [GL #2856]
- 5688. [bug] Zones using KASP and inline-signed zones failed to apply changes from the unsigned zone to the signed zone under certain circumstances. This has been fixed. [GL #2735]
- 5687. [bug] "rndc reload <zonename>" could trigger a redundant reload for an inline-signed zone whose zone file was not modified since the last "rndc reload". This has been fixed. [GL #2855]
- 5686. [func] The number of internal data structures allocated for each zone was reduced. [GL #2829]
- 5685. [bug] named failed to check the opcode of responses when performing zone refreshes, stub zone updates, and UPDATE forwarding. This has been fixed. [GL #2762]
- 5684. [func] The DNS-over-HTTP (DoH) configuration syntax was extended:
  - The maximum number of active DoH connections can now be set using the "http-listener-clients" option. The default is 300.
  - The maximum number of concurrent HTTP/2 streams per connection can now be set using the "http-streams-per-connection" option. The default is 100.
  - Both of these values can also be set on a per-listener basis using the "listener-clients" and

(continues on next page)

(continued from previous page)

		<p>"streams-per-connection" parameters in an "http" statement. [GL #2809]</p>
5683.	[bug]	<p>The configuration-checking code now verifies HTTP paths. [GL !5231]</p>
5682.	[bug]	<p>Some changes to "zone-statistics" settings were not properly processed by "rndc reconfig". This has been fixed. [GL #2820]</p>
5681.	[func]	<p>Relax the checks in the dns_zone_cdscheck() function to allow CDS and CDNSKEY records in the zone that do not match an existing DNSKEY record, as long as the algorithm matches. This allows a clean rollover from one provider to another in a multi-signer DNSSEC configuration. [GL #2710]</p>
5680.	[bug]	<p>HTTP GET requests without query strings caused a crash in DoH code. This has been fixed. [GL !5268]</p>
5679.	[func]	<p>Thread affinity is no longer set. [GL #2822]</p>
5678.	[bug]	<p>The "check DS" code failed to release all resources upon named shutdown when a refresh was in progress. This has been fixed. [GL #2811]</p>
5677.	[func]	<p>Previously, named accepted FORMERR responses both with and without an OPT record, as an indication that a given server did not support EDNS. To implement full compliance with RFC 6891, only FORMERR responses without an OPT record are now accepted. This intentionally breaks communication with servers that do not support EDNS and that incorrectly echo back the query message with the RCODE field set to FORMERR and the QR bit set to 1. [GL #2249]</p>
5676.	[func]	<p>Memory allocation has been substantially refactored; it is now based on the memory allocation API provided by the jemalloc library, which is a new optional build dependency for BIND 9. [GL #2433]</p>
5675.	[bug]	<p>Compatibility with DoH clients has been improved by ignoring the value of the "Accept" HTTP header. [GL !5246]</p>
5674.	[bug]	<p>A shutdown hang was triggered by DoH clients prematurely aborting HTTP/2 streams. This has been fixed. [GL !5245]</p>
5673.	[func]	<p>Add a new build-time option, --disable-doh, to allow building BIND 9 without the libnghttp2 library. [GL #2478]</p>

(continues on next page)

(continued from previous page)

5672. [bug] Authentication of rndc messages could fail if a "controls" statement was configured with multiple key algorithms for the same listener. This has been fixed. [GL #2756]

--- 9.17.16 released ---

5671. [bug] A race condition could occur where two threads were competing for the same set of key file locks, leading to a deadlock. This has been fixed. [GL #2786]

5670. [bug] create\_keydata() created an invalid placeholder keydata record upon a refresh failure, which prevented the database of managed keys from subsequently being read back. This has been fixed. [GL #2686]

5669. [func] KASP support was extended with the "check DS" feature. Zones with "dnssec-policy" and "parental-agents" configured now check for DS presence and can perform automatic KSK rollovers. [GL #1126]

5668. [bug] Rescheduling a setnsec3param() task when a zone failed to load on startup caused a hang on shutdown. This has been fixed. [GL #2791]

5667. [bug] The configuration-checking code failed to account for the inheritance rules of the "dnssec-policy" option. This has been fixed. [GL #2780]

5666. [doc] The safe "edns-udp-size" value was tweaked to match the probing value from BIND 9.16 for better compatibility. [GL #2183]

5665. [bug] If nsupdate sends an SOA request and receives a REFUSED response, it now fails over to the next available server. [GL #2758]

5664. [func] For UDP messages larger than the path MTU, named now sends an empty response with the TC (TrunCated) bit set. In addition, setting the DF (Don't Fragment) flag on outgoing UDP sockets was re-enabled. [GL #2790]

5663. [bug] Non-zero OPCODEs are now properly handled when receiving queries over DNS-over-TLS (DoT) and DNS-over-HTTPS (DoH) channels. [GL #2787]

5662. [bug] Views with recursion disabled are now configured with a default cache size of 2 MB unless "max-cache-size" is explicitly set. This prevents cache RBT hash tables from being needlessly preallocated for such views. [GL #2777]

(continues on next page)

(continued from previous page)

5661.	[bug]	Change 5644 inadvertently introduced a deadlock: when locking the key file mutex for each zone structure in a different view, the "in-view" logic was not considered. This has been fixed. [GL #2783]
5660.	[bug]	The configuration-checking code failed to account for the inheritance rules of the "key-directory" option. [GL #2778]  This change was included in BIND 9.17.15.
5659.	[bug]	When preparing DNS responses, named could replace the letters 'W' (uppercase) and 'w' (lowercase) with '\000'. This has been fixed. [GL #2779]  This change was included in BIND 9.17.15.
5658.	[bug]	Increasing "max-cache-size" for a running named instance (using "rndc reconfig") did not cause the hash tables used by cache databases to be grown accordingly. This has been fixed. [GL #2770]
5657.	[cleanup]	Support was removed for both built-in atomics in old versions of Clang (< 3.6.0) and GCC (< 4.7.0), and atomics emulated with a mutex. [GL #2606]
5656.	[bug]	Named now ensures that large responses work correctly over DNS-over-HTTPS (DoH), and that zone transfer requests over DoH are explicitly rejected. [GL #5148]
5655.	[bug]	Signed, insecure delegation responses prepared by named either lacked the necessary NSEC records or contained duplicate NSEC records when both wildcard expansion and CNAME chaining were required to prepare the response. This has been fixed. [GL #2759]
5654.	[port]	Windows support has been removed. [GL #2690]
5653.	[bug]	A bug that caused the NSEC3 salt to be changed on every restart for zones using KASP has been fixed. [GL #2725]

--- 9.17.14 released ---

5652.	[bug]	A copy-and-paste error in change 5584 caused the IP_DONTFRAG socket option to be enabled instead of disabled. This has been fixed. [GL #2746]
5651.	[func]	Refactor zone dumping to be processed asynchronously via the uv_work_t thread pool API. [GL #2732]
5650.	[bug]	Prevent a crash that could occur if serve-stale was enabled and a prefetch was triggered during a query

(continues on next page)

(continued from previous page)

		restart. [GL #2733]
5649.	[bug]	If a query was answered with stale data on a server with DNS64 enabled, an assertion could occur if a non-stale answer arrived afterward. [GL #2731]
5648.	[bug]	The calculation of the estimated IXFR transaction size in <code>dns_journal_iter_init()</code> was invalid. [GL #2685]
5647.	[func]	The interface manager has been refactored to use fewer client manager objects, which in turn use fewer memory contexts and tasks. This should result in less fragmented memory and better startup performance. [GL #2433]
5646.	[bug]	The default TCP timeout for <code>rndc</code> has been increased to 60 seconds. This was its original value, but it had been inadvertently lowered to 10 when <code>rndc</code> was updated to use the network manager. [GL #2643]
5645.	[cleanup]	Remove the rarely-used <code>dns_name_copy()</code> function and rename <code>dns_name_copynf()</code> to <code>dns_name_copy()</code> . [GL #5081]
5644.	[bug]	Fix a race condition in reading and writing key files for zones using KASP and configured in multiple views. [GL #1875]
5643.	[placeholder]	
5642.	[bug]	Zones which are configured in multiple views with different values set for "dnssec-policy" and with identical values set for "key-directory" are now detected and treated as a configuration error. [GL #2463]
5641.	[bug]	Address a potential memory leak in <code>dst_key_fromnamedfile()</code> . [GL #2689]
5640.	[func]	Add new configuration options for setting the size of receive and send buffers in the operating system: "tcp-receive-buffer", "tcp-send-buffer", "udp-receive-buffer", and "udp-send-buffer". [GL #2313]
5639.	[bug]	Check that the first and last SOA record of an AXFR are consistent. [GL #2528]

--- 9.17.13 released ---

5638.	[bug]	Improvements related to network manager/task manager integration: <ul style="list-style-type: none"> <li>- <code>isc_managers_create()</code> and <code>isc_managers_destroy()</code> functions were added to handle setup and teardown of</li> </ul>
-------	-------	--

(continues on next page)

(continued from previous page)

		<p>netmgr, taskmgr, timermgr, and socketmgr, since these require a precise order of operations now.</p> <ul style="list-style-type: none"> <li>- Event queue processing is now quantized to prevent infinite looping.</li> <li>- The netmgr can now be paused from within a netmgr thread.</li> <li>- Deadlocks due to a conflict between netmgr's pause/resume and listen/stoplistening operations were fixed.</li> </ul> <p>[GL #2654]</p>
5637.	[placeholder]	
5636.	[bug]	<p>named and named-checkconf did not report an error when multiple zones with the "dnssec-policy" option set were using the same zone file. This has been fixed.</p> <p>[GL #2603]</p>
5635.	[bug]	<p>Journal compaction could fail when a journal with invalid transaction headers was not detected at startup. This has been fixed. [GL #2670]</p>
5634.	[bug]	<p>If "dnssec-policy" was active and a private key file was temporarily offline during a rekey event, named could incorrectly introduce replacement keys and break a signed zone. This has been fixed. [GL #2596]</p>
5633.	[doc]	<p>The "inline-signing" option was incorrectly described as being inherited from the "options"/"view" levels and was incorrectly accepted at those levels without effect. This has been fixed. [GL #2536]</p>
5632.	[func]	<p>Add a new built-in KASP, "insecure", which is used to transition a zone from a signed to an unsigned state. The existing built-in KASP "none" should no longer be used to unsign a zone. [GL #2645]</p>
5631.	[protocol]	<p>Update the implementation of the ZONEMD RR type to match RFC 8976. [GL #2658]</p>
5630.	[func]	<p>Treat DNSSEC responses containing NSEC3 records with iteration counts greater than 150 as insecure.</p> <p>[GL #2445]</p>
5629.	[func]	<p>Reduce the maximum supported number of NSEC3 iterations that can be configured for a zone to 150. [GL #2642]</p>
5628.	[bug]	<p>Host and nslookup could crash upon receiving a SERVFAIL response. This has been fixed. [GL #2564]</p>
5627.	[bug]	<p>RRSIG(SOA) RRsets placed anywhere other than at the zone apex were triggering infinite resigning loops. This has</p>

(continues on next page)

(continued from previous page)

		been fixed. [GL #2650]
5626.	[bug]	When generating zone signing keys, KASP now also checks for key ID conflicts among newly created keys, rather than just between new and existing ones. [GL #2628]
5625.	[bug]	A deadlock could occur when multiple "rndc addzone", "rndc delzone", and/or "rndc modzone" commands were invoked simultaneously for different zones. This has been fixed. [GL #2626]
5624.	[func]	Task manager events are now processed inside network manager loops. The task manager no longer needs its own set of worker threads, which improves resolver performance. [GL #2638]
5623.	[bug]	When named was shut down during an ongoing zone transfer, xfrin_fail() could incorrectly be called twice. This has been fixed. [GL #2630]
5622.	[cleanup]	The lib/samples/ directory has been removed, as export versions of libraries are no longer maintained. [GL #4835]
5621.	[placeholder]	
5620.	[bug]	If zone journal files written by BIND 9.16.11 or earlier were present when BIND was upgraded, the zone file for that zone could have been inadvertently rewritten with the current zone contents. This caused the original zone file structure (e.g. comments, \$INCLUDE directives) to be lost, although the zone data itself was preserved. This has been fixed. [GL #2623]
5619.	[protocol]	Implement draft-vandijk-dnsop-nsec-ttl, updating the protocol such that NSEC(3) TTL values are set to the minimum of the SOA MINIMUM value or the SOA TTL. [GL #2347]
5618.	[bug]	Change 5149 introduced some inconsistencies in the way record TTLs were presented in cache dumps. These inconsistencies have been eliminated. [GL #389] [GL #2289]

--- 9.17.12 released ---

5617.	[placeholder]	
5616.	[security]	named crashed when a DNAME record placed in the ANSWER section during DNAME chasing turned out to be the final answer to a client query. (CVE-2021-25215) [GL #2540]

(continues on next page)

(continued from previous page)

- 5615. [security] Insufficient IXFR checks could result in named serving a zone without an SOA record at the apex, leading to a RUNTIME\_CHECK assertion failure when the zone was subsequently refreshed. This has been fixed by adding an owner name check for all SOA records which are included in a zone transfer. (CVE-2021-25214) [GL #2467]
- 5614. [bug] Ensure all resources are properly cleaned up when a call to gss\_accept\_sec\_context() fails. [GL #2620]
- 5613. [bug] It was possible to write an invalid transaction header in the journal file for a managed-keys database after upgrading. This has been fixed. Invalid headers in existing journal files are detected and named is able to recover from them. [GL #2600]
- 5612. [bug] Continued refactoring of the network manager:
  - allow recovery from read and connect timeout events,
  - ensure that calls to isc\_nm\_\*connect() always return the connection status via a callback function.
 [GL #2401]
- 5611. [func] Set "stale-answer-client-timeout" to "off" by default. [GL #2608]
- 5610. [bug] Prevent a crash which could happen when a lookup triggered by "stale-answer-client-timeout" was attempted right after recursion for a client query finished. [GL #2594]
- 5609. [func] The ISC implementation of SPNEGO was removed from BIND 9 source code. It was no longer necessary as all major contemporary Kerberos/GSSAPI libraries include support for SPNEGO. [GL #2607]
- 5608. [bug] When sending queries over TCP, dig now properly handles "+tries=1 +retry=0" by not retrying the connection when the remote server closes the connection prematurely. [GL #2490]
- 5607. [bug] As "rndc dnssec -checkds" and "rndc dnssec -rollover" commands may affect the next scheduled key event, reconfiguration of zone keys is now triggered after receiving either of these commands to prevent unnecessary key rollover delays. [GL #2488]
- 5606. [bug] CDS/CDNSKEY DELETE records are now removed when a zone transitions from a secure to an insecure state. named-checkzone also no longer reports an error when such records are found in an unsigned zone. [GL #2517]

(continues on next page)

(continued from previous page)

5605.	[bug]	"dig -u" now uses the CLOCK_REALTIME clock source for more accurate time reporting. [GL #2592]
5604.	[experimental]	A "filter-a.so" plugin, which is similar to the "filter-aaaa.so" plugin but which omits A records instead of AAAA records, has been added. Thanks to GitLab user @treysis. [GL #2585]
5603.	[placeholder]	
5602.	[bug]	Fix TCPDNS and TLSDNS timers in Network Manager. This makes the "tcp-initial-timeout" and "tcp-idle-timeout" options work correctly again. [GL #2583]
5601.	[bug]	Zones using KASP could not be thawed after they were frozen using "rndc freeze". This has been fixed. [GL #2523]
5600.	[bug]	Send a full certificate chain instead of just the leaf certificate to DNS-over-TLS (DoT) and DNS-over-HTTPS (DoH) clients. This makes BIND 9 DoT/DoH servers compatible with a broader set of clients. [GL #2514]
5599.	[bug]	Fix a named crash which occurred after skipping a primary server while transferring a zone over TLS. [GL #2562]
5598.	[port]	Silence -Wchar-subscripts compiler warnings triggered on some platforms due to calling character classification functions declared in the <ctype.h> header with arguments of type char. [GL #2567]

--- 9.17.11 released ---

5597.	[bug]	When serve-stale was enabled and starting the recursive resolution process for a query failed, a named instance could crash if it was configured as both a recursive and authoritative server. This problem was introduced by change 5573 and has now been fixed. [GL #2565]
5596.	[func]	Client-side support for DNS-over-HTTPS (DoH) has been added to dig. "dig +https" can now query a server via HTTP/2. [GL #1641]
5595.	[cleanup]	Public header files for BIND 9 libraries no longer directly include third-party library headers. This prevents the need to include paths to third-party header files in CFLAGS whenever BIND 9 public header files are used, which could cause build-time issues on hosts with older versions of BIND 9 installed. [GL #2357]
5594.	[bug]	Building with --enable-dnsrps --enable-dnsrps-dl failed.

(continues on next page)

(continued from previous page)

		[GL #2298]
5593.	[bug]	Journal files written by older versions of named can now be read when loading zones, so that journal incompatibility does not cause problems on upgrade. Outdated journals are updated to the new format after loading. [GL #2505]
5592.	[bug]	Prevent hazard pointer table overflows on machines with many cores, by allowing the thread IDs (serving as indices into hazard pointer tables) of finished threads to be reused by those created later. [GL #2396]
5591.	[bug]	Fix a crash that occurred when "stale-answer-client-timeout" was triggered without any (stale) data available in the cache to answer the query. [GL #2503]
5590.	[bug]	NSEC3 records were not immediately created for dynamic zones using NSEC3 with "dnssec-policy", resulting in such zones going bogus. Add code to process the NSEC3PARAM queue at zone load time so that NSEC3 records for such zones are created immediately. [GL #2498]
5589.	[placeholder]	
5588.	[func]	Add a new "purge-keys" option for "dnssec-policy". This option determines the period of time for which key files are retained after they become obsolete. [GL #2408]
5587.	[bug]	A standalone libtool script no longer needs to be present in PATH to build BIND 9 from a source tarball prepared using "make dist". [GL #2504]
5586.	[bug]	An invalid direction field in a LOC record resulted in an INSIST failure when a zone file containing such a record was loaded. [GL #2499]
5585.	[func]	Memory contexts and memory pool implementations were refactored to reduce lock contention for shared memory contexts by replacing mutexes with atomic operations. The internal memory allocator was simplified so that it is only a thin wrapper around the system allocator. This change made the "-M external" named option redundant and it was therefore removed. [GL #2433]
5584.	[bug]	No longer set the IP_DONTFRAG option on UDP sockets, to prevent dropping outgoing packets exceeding "max-udp-size". [GL #2466]
5583.	[func]	Changes to DNS-over-HTTPS (DoH) configuration syntax: - When "http" is specified in "listen-on" or

(continues on next page)

(continued from previous page)

		<p>"listen-on-v6" statements, "tls" must also now be specified. If an unencrypted connection is desired (for example, when running behind a reverse proxy), use "tls none".</p> <p>- "http default" can now be specified in "listen-on" and "listen-on-v6" statements to use the default HTTP endpoint of "/dns-query". It is no longer necessary to include an "http" statement in named.conf unless overriding this value.</p> <p>[GL #2472]</p>
5582.	[bug]	<p>BIND 9 failed to build when static OpenSSL libraries were used and the pkg-config files for libssl and/or libcrypto were unavailable. This has been fixed by ensuring that the correct linking order for libssl and libcrypto is always used. [GL #2402]</p>
5581.	[bug]	<p>Fix a memory leak that occurred when inline-signed zones were added to the configuration, followed by a reconfiguration of named. [GL #2041]</p>
5580.	[test]	<p>The system test framework no longer differentiates between SKIPPED and UNTESTED system test results. Any system test which is not run is now marked as SKIPPED. [GL !4517]</p>
5579.	[bug]	<p>If an invalid key name (e.g. "a.b") was specified in a primaries list in named.conf, the wrong size was passed to isc_mem_put(), resulting in the returned memory being put on the wrong free list. This prevented named from starting up. [GL #2460]</p>

		<p>--- 9.17.10 released ---</p>
5578.	[protocol]	<p>Make "check-names" accept A records below "_spf", "_spf_rate", and "_spf_verify" labels in order to cater for the "exists" SPF mechanism specified in RFC 7208 section 5.7 and appendix D.1. [GL #2377]</p>
5577.	[bug]	<p>Fix the "three is a crowd" key rollover bug in KASP by correctly implementing Equation (2) of the "Flexible and Robust Key Rollover" paper. [GL #2375]</p>
5576.	[experimental]	<p>Initial server-side implementation of DNS-over-HTTPS (DoH). Support for both TLS-encrypted and unencrypted HTTP/2 connections has been added to the network manager and integrated into named. (Note: there is currently no client-side support for DNS-over-HTTPS; this will be added to dig in a future release.) [GL #1144]</p>
5575.	[bug]	<p>When migrating to KASP, BIND 9 considered keys with the "Inactive" and/or "Delete" timing metadata to be</p>

(continues on next page)

(continued from previous page)

		possible active keys. This has been fixed. [GL #2406]
5574.	[func]	Incoming zone transfers can now use TLS. Addresses in a "primaries" list take an optional "tls" argument, specifying either a previously configured "tls" block or "ephemeral"; SOA queries and zone transfer requests are then sent via TLS. [GL #2392]
5573.	[func]	When serve-stale is enabled and stale data is available, named now returns stale answers upon encountering any unexpected error in the query resolution process. However, the "stale-refresh-time" window is still only started upon a timeout. [GL #2434]
5572.	[bug]	Address potential double free in generatexml(). [GL #2420]
5571.	[bug]	named failed to start when its configuration included a zone with a non-builtin "allow-update" ACL attached. [GL #2413]
5570.	[bug]	Improve performance of the DNSSEC verification code by reducing the number of repeated calls to dns_dnssec_keyfromrdata(). [GL #2073]
5569.	[bug]	Emit useful error message when "rndc retransfer" is applied to a zone of inappropriate type. [GL #2342]
5568.	[bug]	Fixed a crash in "dnssec-keyfromlabel" when using ECDSA keys. [GL #2178]
5567.	[bug]	Dig now reports unknown dash options while pre-parsing the options. This prevents "-multi" instead of "+multi" from reporting memory usage before ending option parsing with "Invalid option: -lti". [GL #2403]
5566.	[func]	Add "stale-answer-client-timeout" option, which is the amount of time a recursive resolver waits before attempting to answer the query using stale data from cache. [GL #2247]
5565.	[func]	The SONAMES for BIND 9 libraries now include the current BIND 9 version number, in an effort to tightly couple internal libraries with a specific release. [GL #2387]
5564.	[cleanup]	Network manager's TLSDNS module was refactored to use libuv and libssl directly instead of a stack of TCP/TLS sockets. [GL #2335]
5563.	[cleanup]	Changed several obsolete configuration options to ancient, making them fatal errors. Also cleaned up the number of clause flags in the configuration parser.

(continues on next page)

(continued from previous page)

		[GL #1086]
5562.	[placeholder]	
5561.	[bug]	KASP incorrectly set signature validity to the value of the DNSKEY signature validity. This is now fixed. [GL #2383]
5560.	[func]	The default value of "max-stale-ttl" has been changed from 12 hours to 1 day and the default value of "stale-answer-ttl" has been changed from 1 second to 30 seconds, following RFC 8767 recommendations. [GL #2248]

		--- 9.17.9 released ---
5559.	[bug]	The --with-maxminddb=PATH form of the build-time option enabling support for libmaxminddb was not working correctly. This has been fixed. [GL #2366]
5558.	[bug]	Asynchronous hook modules could trigger an assertion failure when the fetch handle was detached too late. Thanks to Jinmei Tatuya at Infoblox. [GL #2379]
5557.	[bug]	Prevent RBTDB instances from being destroyed by multiple threads at the same time. [GL #2317]
5556.	[bug]	Further tweak newline printing in dnssec-signzone and dnssec-verify. [GL #2359]
5555.	[placeholder]	
5554.	[bug]	dnssec-signzone and dnssec-verify were missing newlines between log messages. [GL #2359]
5553.	[bug]	When reconfiguring named, removing "auto-dnssec" did not turn off DNSSEC maintenance. [GL #2341]
5552.	[func]	When switching to "dnssec-policy none;", named now permits a safe transition to insecure mode and publishes the CDS and CDNSKEY DELETE records, as described in RFC 8078. [GL #1750]
5551.	[bug]	named no longer attempts to assign threads to CPUs outside the CPU affinity set. Thanks to Ole Bjørn Hessen. [GL #2245]
5550.	[func]	dnssec-signzone and named now log a warning when falling back to the "increment" SOA serial method. [GL #2058]
5549.	[protocol]	ipv4only.arpa is now served when DNS64 is configured. [GL #385]

(continues on next page)

(continued from previous page)

5548. [placeholder]  
 5547. [placeholder]

```

--- 9.17.8 released ---

5546. [placeholder]

5545. [func]      OS support for load-balanced sockets is no longer
                    required to receive incoming queries in multiple netmgr
                    threads. [GL #2137]

5544. [func]      Restore the default value of "nocookie-udp-size" to 4096
                    bytes. [GL #2250]

5543. [bug]       Fix UDP performance issues caused by making netmgr
                    callbacks asynchronous-only. [GL #2320]

5542. [bug]       Refactor netmgr. [GL #1920] [GL #2034] [GL #2061]
                    [GL #2194] [GL #2221] [GL #2266] [GL #2283] [GL #2318]
                    [GL #2321]

5541. [func]      Adjust the "max-recursion-queries" default from 75 to
                    100. [GL #2305]

5540. [port]      Fix building with native PKCS#11 support for AEP Keyper.
                    [GL #2315]

5539. [bug]       Tighten handling of missing DNS COOKIE responses over
                    UDP by falling back to TCP. [GL #2275]

5538. [func]      Add NSEC3 support to KASP. A new option for
                    "dnssec-policy", "nsec3param", can be used to set the
                    desired NSEC3 parameters. NSEC3 salt collisions are
                    automatically prevented during resalting. Salt
                    generation is now logged with zone context. [GL #1620]

5537. [func]      The query plugin mechanism has been extended
                    to support asynchronous operations. For example, a
                    plugin can now trigger recursion and resume
                    processing when it is complete. Thanks to Jinmei
                    Tatuya at Infoblox. [GL #2141]

5536. [func]      Dig can now report the DNS64 prefixes in use
                    (+dns64prefix). [GL #1154]

5535. [bug]       dig/nslookup/host could crash on shutdown after an
                    interrupt. [GL #2287] [GL #2288]

5534. [bug]       The CNAME synthesized from a DNAME was incorrectly
                    followed when the QTYPE was CNAME or ANY. [GL #2280]
    
```

--- 9.17.7 released ---

- 5533. [func] Add the "stale-refresh-time" option, a time window that starts after a failed lookup, during which a stale RRset is served directly from cache before a new attempt to refresh it is made. [GL #2066]
- 5532. [cleanup] Unused header files were removed: bin/rndc/include/rndc/os.h, lib/isc/timer\_p.h, lib/isccfg/include/isccfg/dnsconf.h and code related to those files. [GL #1913]
- 5531. [func] Add support for DNS over TLS (DoT) to dig and named. dig output now includes the transport protocol used. [GL #1816] [GL #1840]
- 5530. [bug] dnstap did not capture responses to forwarded UPDATE requests. [GL #2252]
- 5529. [func] The network manager API is now used by named to send zone transfer requests. [GL #2016]
- 5528. [func] Convert dig, host, and nslookup to use the network manager API. As a side effect of this change, "dig +unexpected" no longer works, and has been disabled. [GL #2140]
- 5527. [bug] A NULL pointer dereference occurred when creating an NTA recheck query failed. [GL #2244]
- 5526. [bug] Fix a race/NULL dereference in TCPDNS read. [GL #2227]
- 5525. [placeholder]
- 5524. [func] Added functionality to the network manager to support outgoing DNS queries in addition to incoming ones. [GL #2235]
- 5523. [bug] The initial lookup in a zone transitioning to/from a signed state could fail if the DNSKEY RRset was not found. [GL #2236]
- 5522. [bug] Fixed a race/NULL dereference in TCPDNS send. [GL #2227]
- 5521. [func] All use of libltdl was dropped. libuv's shared library handling interface is now used instead. [GL #2278]
- 5520. [bug] Fixed a number of shutdown races, reference counting errors, and spurious log messages that could occur in the network manager. [GL #2221]
- 5519. [cleanup] Unused source code was removed: lib/dns/dbtable.c, lib/dns/portlist.c, lib/isc/bufferlist.c, and code

(continues on next page)

(continued from previous page)

```

related to those files. [GL #2060]
5518. [bug] Stub zones now work correctly with primary servers using
"minimal-responses yes". [GL #1736]
5517. [bug] Do not treat UV_EOF as a TCP4RecvErr or a TCP6RecvErr.
[GL #2208]

```

```

--- 9.17.6 released ---
5516. [func] The default EDNS buffer size has been changed from 4096
to 1232 bytes, the EDNS buffer size probing has been
removed, and named now sets the DF (Don't Fragment) flag
on outgoing UDP packets. [GL #2183]
5515. [func] Add 'rndc dnssec -rollover' command to trigger a manual
rollover for a specific key. [GL #1749]
5514. [bug] Fix KASP expected key size for Ed25519 and Ed448.
[GL #2171]
5513. [doc] The ARM section describing the "rrset-order" statement
was rewritten to make it unambiguous and up-to-date with
the source code. [GL #2139]
5512. [bug] "rrset-order" rules using "order none" were causing
named to crash despite named-checkconf treating them as
valid. [GL #2139]
5511. [bug] 'dig -u +yaml' failed to display timestamps to the
microsecond. [GL #2190]
5510. [bug] Implement the attach/detach semantics for dns_message_t
to fix a data race in accessing an already-destroyed
fctx->rmessage. [GL #2124]
5509. [bug] filter-aaaa: named crashed upon shutdown if it was in
the process of recursing for A RRsets. [GL #1040]
5508. [func] Added new parameter "-expired" for "rndc dumpdb" that
also prints expired RRsets (awaiting cleanup) to the
dump file. [GL #1870]
5507. [bug] Named could compute incorrect SIG(0) responses.
[GL #2109]
5506. [bug] Properly handle failed sysconf() calls, so we don't
report invalid memory size. [GL #2166]
5505. [bug] Updating contents of a mixed-case RPZ could cause some
rules to be ignored. [GL #2169]

```

(continues on next page)

(continued from previous page)

- 5504. [func] The "glue-cache" option has been marked as deprecated. The glue cache feature will be permanently enabled in a future release. [GL #2146]
- 5503. [bug] Cleaned up reference counting of network manager handles, now using isc\_nmhandle\_attach() and \_detach() instead of \_ref() and \_unref(). [GL #2122]

- 9.17.5 released ---
- 5502. [func] 'dig +bufsize=0' no longer disables EDNS. [GL #2054]
  - 5501. [func] Log CDS/CDNSKEY publication. [GL #1748]
  - 5500. [bug] Fix (non-)publication of CDS and CDNSKEY records. [GL #2103]
  - 5499. [func] Add '-P ds' and '-D ds' arguments to dnssec-settime. [GL #1748]
  - 5498. [test] The --with-gperftools-profiler configure option was removed. [GL !4045]
  - 5497. [placeholder]
  - 5496. [bug] Address a TSAN report by ensuring each rate limiter object holds a reference to its task. [GL #2081]
  - 5495. [bug] With query minimization enabled, named failed to resolve ip6.arpa. names that had extra labels to the left of the IPv6 part. [GL #1847]
  - 5494. [bug] Silence the EPROTO syslog message on older systems. [GL #1928]
  - 5493. [bug] Fix off-by-one error when calculating new hash table size. [GL #2104]
  - 5492. [bug] Tighten LOC parsing to reject a period (".") and/or "m" as a value. Fix handling of negative altitudes which are not whole meters. [GL #2074]
  - 5491. [bug] rbtversion->glue\_table\_size could be read without the appropriate lock being held. [GL #2080]
  - 5490. [func] Refactor readline support to use pkg-config and add support for the editline library. [GL !3942]
  - 5489. [bug] Named erroneously accepted certain invalid resource records that were incorrectly processed after subsequently being written to disk and loaded back, as the wire format differed. Such records include: CERT,

(continues on next page)

(continued from previous page)

		IPSECKEY, NSEC3, NSEC3PARAM, NXT, SIG, TLSA, WKS, and X25. [GL !3953]
5488.	[bug]	NTA code needed to have a weak reference on its associated view to prevent the latter from being deleted while NTA tests were being performed. [GL #2067]
5487.	[cleanup]	Update managed keys log messages to be less confusing. [GL #2027]
5486.	[func]	Add 'rndc dnssec -checkds' command, which signals to named that the DS record for a given zone or key has been updated in the parent zone. [GL #1613]

		--- 9.17.4 released ---
5485.	[placeholder]	
5484.	[func]	Expire zero TTL records quickly rather than using them for stale answers. [GL #1829]
5483.	[func]	Keeping "stale" answers in cache has been disabled by default and can be re-enabled with a new configuration option "stale-cache-enable". [GL #1712]
5482.	[bug]	If the Duplicate Address Detection (DAD) mechanism had not yet finished after adding a new IPv6 address to the system, BIND 9 would fail to bind to IPv6 addresses in a tentative state. [GL #2038]
5481.	[security]	"update-policy" rules of type "subdomain" were incorrectly treated as "zonesub" rules, which allowed keys used in "subdomain" rules to update names outside of the specified subdomains. The problem was fixed by making sure "subdomain" rules are again processed as described in the ARM. (CVE-2020-8624) [GL #2055]
5480.	[security]	When BIND 9 was compiled with native PKCS#11 support, it was possible to trigger an assertion failure in code determining the number of bits in the PKCS#11 RSA public key with a specially crafted packet. (CVE-2020-8623) [GL #2037]
5479.	[security]	named could crash in certain query resolution scenarios where QNAME minimization and forwarding were both enabled. (CVE-2020-8621) [GL #1997]
5478.	[security]	It was possible to trigger an assertion failure by sending a specially crafted large TCP DNS message. (CVE-2020-8620) [GL #1996]
5477.	[bug]	The idle timeout for connected TCP sockets, which was

(continues on next page)

(continued from previous page)

		previously set to a high fixed value, is now derived from the client query processing timeout configured for a resolver. [GL #2024]
5476.	[security]	It was possible to trigger an assertion failure when verifying the response to a TSIG-signed request. (CVE-2020-8622) [GL #2028]
5475.	[bug]	Wildcard RPZ passthru rules could incorrectly be overridden by other rules that were loaded from RPZ zones which appeared later in the "response-policy" statement. This has been fixed. [GL #1619]
5474.	[bug]	dns_rdata_hip_next() failed to return ISC_R_NOMORE when it should have. [GL #3880]
5473.	[func]	The RBT hash table implementation has been changed to use a faster hash function (HalfSipHash2-4) and Fibonacci hashing for better distribution. Setting "max-cache-size" now preallocates a fixed-size hash table so that rehashing does not cause resolution brownouts while the hash table is grown. [GL #1775]
5472.	[func]	The statistics channel has been updated to use the new network manager. [GL #2022]
5471.	[bug]	The introduction of KASP support inadvertently caused the second field of "sig-validity-interval" to always be calculated in hours, even in cases when it should have been calculated in days. This has been fixed. (Thanks to Tony Finch.) [GL #3735]
5470.	[port]	gsskrb5_register_acceptor_identity() is now only called if gssapi_krb5.h is present. [GL #1995]
5469.	[port]	On illumos, a constant called SEC is already defined in <sys/time.h>, which conflicts with an identically named constant in libbind9. This conflict has been resolved. [GL #1993]
5468.	[bug]	Addressed potential double unlock in process_fd(). [GL #2005]
5467.	[func]	The control channel and the rndc utility have been updated to use the new network manager. To support this, the network manager was updated to enable the initiation of client TCP connections. Its internal reference counting has been refactored.
		Note: As a side effect of this change, rndc cannot currently be used with UNIX-domain sockets, and its default timeout has changed from 60 seconds to 30.

(continues on next page)

(continued from previous page)

		These will be addressed in a future release. [GL #1759]
5466.	[bug]	Addressed an error in recursive clients stats reporting. [GL #1719]
5465.	[func]	Added fallback to built-in trust-anchors, managed-keys, or trusted-keys if the bindkeys-file (bind.keys) cannot be parsed. [GL #1235]
5464.	[bug]	Requesting more than 128 files to be saved when rolling dnstap log files caused a buffer overflow. This has been fixed. [GL #1989]
5463.	[placeholder]	
5462.	[bug]	Move LMDB locking from LMDB itself to named. [GL #1976]
5461.	[bug]	The STALE rdataset header attribute was updated while the write lock was not being held, leading to incorrect statistics. The header attributes are now converted to use atomic operations. [GL #1475]
5460.	[cleanup]	tsig-keygen was previously an alias for ddns-confgen and was documented in the ddns-confgen man page. This has been reversed; tsig-keygen is now the primary name. [GL #1998]
5459.	[bug]	Fixed bad isc_mem_put() size when an invalid type was specified in an "update-policy" rule. [GL #1990]

		--- 9.17.3 released ---
5458.	[bug]	Prevent a theoretically possible NULL dereference caused by a data race between zone_maintenance() and dns_zone_setview_helper(). [GL #1627]
5457.	[placeholder]	
5456.	[func]	Added "primaries" as a synonym for "masters" in named.conf, and "primary-only" as a synonym for "master-only" in the parameters to "notify", to bring terminology up-to-date with RFC 8499. [GL #1948]
5455.	[bug]	named could crash when cleaning dead nodes in lib/dns/rbtdb.c that were being reused. [GL #1968]
5454.	[bug]	Address a startup crash that occurred when the server was under load and the root zone had not yet been loaded. [GL #1862]
5453.	[bug]	named crashed on shutdown when a new rndc connection was

(continues on next page)

(continued from previous page)

		received during shutdown. [GL #1747]
5452.	[bug]	The "blackhole" ACL was accidentally disabled for client queries. [GL #1936]
5451.	[func]	Add 'rndc dnssec -status' command. [GL #1612]
5450.	[placeholder]	
5449.	[bug]	Fix a socket shutdown race in netmgr udp. [GL #1938]
5448.	[bug]	Fix a race condition in isc_nm_tcpdns_send(). [GL #1937]
5447.	[bug]	IPv6 addresses ending in "::" could break YAML parsing. A "0" is now appended to such addresses in YAML output from dig, mdig, delv, and dnstap-read. [GL #1952]
5446.	[bug]	The validator could fail to accept a properly signed RRset if an unsupported algorithm appeared earlier in the DNSKEY RRset than a supported algorithm. It could also stop if it detected a malformed public key. [GL #1689]
5445.	[cleanup]	Disable and disallow static linking. [GL #1933]
5444.	[bug]	'rndc dnstap -roll <value>' did not limit the number of saved files to <value>. [GL #13728]
5443.	[bug]	The "primary" and "secondary" keywords, when used as parameters for "check-names", were not processed correctly and were being ignored. [GL #1949]
5442.	[func]	Add support for outgoing TCP connections in netmgr. [GL #1958]
5441.	[placeholder]	
5440.	[placeholder]	
5439.	[bug]	The DS RRset returned by dns_keynode_dsset() was used in a non-thread-safe manner. [GL #1926]

--- 9.17.2 released ---

5438.	[bug]	Fix a race in TCP accepting code. [GL #1930]
5437.	[bug]	Fix a data race in lib/dns/resolver.c:log_formerr(). [GL #1808]
5436.	[security]	It was possible to trigger an INSIST when determining

(continues on next page)

(continued from previous page)

		whether a record would fit into a TCP message buffer. (CVE-2020-8618) [GL #1850]
5435.	[tests]	Add RFC 4592 responses examples to the wildcard system test. [GL #1718]
5434.	[security]	It was possible to trigger an INSIST in lib/dns/rbtdb.c:new_reference() with a particular zone content and query patterns. (CVE-2020-8619) [GL #1111] [GL #1718]
5433.	[placeholder]	
5432.	[bug]	Check the question section when processing AXFR, IXFR, and SOA replies when transferring a zone in. [GL #1683]
5431.	[func]	Reject DS records at the zone apex when loading master files. Log but otherwise ignore attempts to add DS records at the zone apex via UPDATE. [GL #1798]
5430.	[doc]	Update docs - with netmgr, a separate listening socket is created for each IPv6 interface (just as with IPv4). [GL #1782]
5429.	[cleanup]	Move BIND binaries which are neither daemons nor administrative programs to \$bindir. [GL #1724]
5428.	[bug]	Clean up GSSAPI resources in nsupdate only after taskmgr has been destroyed. Thanks to Petr Menšík. [GL #13316]
5427.	[placeholder]	
5426.	[bug]	Don't abort() when setting SO_INCOMING_CPU on the socket fails. [GL #1911]
5425.	[func]	The default value of "max-stale-ttl" has been changed from 1 week to 12 hours. [GL #1877]
5424.	[bug]	With KASP, when creating a successor key, the "goal" state of the current active key (predecessor) was not changed and thus never removed from the zone. [GL #1846]
5423.	[bug]	Fix a bug in keymgr_key_has_successor(): it incorrectly returned true if any other key in the keyring had a successor. [GL #1845]
5422.	[bug]	When using dnssec-policy, print correct key timing metadata. [GL #1843]
5421.	[bug]	Fix a race that could cause named to crash when looking up the nodename of an RBT node if the tree was modified. [GL #1857]

(continues on next page)

(continued from previous page)

- 5420. [bug] Add missing `isc_{mutex,conditional}_destroy()` calls that caused a memory leak on FreeBSD. [GL #1893]
- 5419. [func] Add new `dig` command line option, `"+qid=<num>"`, which allows the query ID to be set to an arbitrary value. Add a new `./configure` option, `--enable-singletrace`, which allows trace logging of a single query when QID is set to 0. [GL #1851]
- 5418. [bug] `delv` failed to parse deprecated `trusted-keys-style` trust anchors. [GL #1860]
- 5417. [cleanup] The code determining the advertised UDP buffer size in outgoing EDNS queries has been refactored to improve its clarity. [GL #1868]
- 5416. [bug] Fix a lock order inversion in `lib/isc/unix/socket.c`. [GL #1859]
- 5415. [test] Address race in `dnssec` system test that led to test failures. [GL #1852]
- 5414. [test] Adjust time allowed for journal truncation to occur in `nsupdate` system test to avoid test failure. [GL #1855]
- 5413. [test] Address race in `autosign` system test that led to test failures. [GL #1852]
- 5412. [bug] `'provide-ixfr no;'` failed to return up-to-date responses when the serial was greater than or equal to the current serial. [GL #1714]
- 5411. [cleanup] TCP accept code has been refactored to use a single `accept()` and pass the accepted socket to child threads for processing. [GL #13320]
- 5410. [func] Add the ability to specify per-type record count limits, which are enforced when adding records via `UPDATE`, in an `"update-policy"` statement. [GL #1657]
- 5409. [performance] When looking up NSEC3 data in a zone database, skip the check for empty non-terminal nodes; the NSEC3 tree does not have any. [GL #1834]
- 5408. [protocol] Print Extended DNS Errors if present in OPT record. [GL #1835]
- 5407. [func] Zone timers are now exported via statistics channel. Thanks to Paul Frieden, Verizon Media. [GL #1232]

(continues on next page)

(continued from previous page)

- 5406. [func] Add a new logging category, "rpz-passthru", which allows RPZ passthru actions to be logged in a separate channel. [GL #54]
- 5405. [bug] 'named-checkconf -p' could include spurious text in server-addresses statements due to an uninitialized DSCP value. [GL #1812]
- 5404. [bug] 'named-checkconf -z' could incorrectly indicate success if errors were found in one view but not in a subsequent one. [GL #1807]
- 5403. [func] Do not set UDP receive/send buffer sizes - use system defaults. [GL #1713]
- 5402. [bug] On FreeBSD, use SO\_REUSEPORT\_LB instead of SO\_REUSEPORT. Enable use of SO\_REUSEADDR on all platforms which support it. [GL #13365]
- 5401. [bug] The number of input queues allocated during dnstap initialization was too low, which could prevent some dnstap data from being logged. [GL #1795]
- 5400. [func] Add engine support to OpenSSL EdDSA implementation. [GL #1763]
- 5399. [func] Add engine support to OpenSSL ECDSA implementation. [GL #1534]
- 5398. [bug] Named could fail to restart if a zone with a double quote (") in its name was added with 'rndc addzone'. [GL #1695]
- 5397. [func] Update PKCS#11 EdDSA implementation to PKCS#11 v3.0. Thanks to Aaron Thompson. [GL #13326]
- 5396. [func] When necessary (i.e. in libuv >= 1.37), use the UV\_UDP\_RECVMMMSG flag to enable recvmmmsg() support in libuv. [GL #1797]
- 5395. [security] Further limit the number of queries that can be triggered from a request. Root and TLD servers are no longer exempt from max-recursion-queries. Fetches for missing name server address records are limited to 4 for any domain. (CVE-2020-8616) [GL #1388]
- 5394. [cleanup] Named formerly attempted to change the effective UID and GID in named\_os\_openfile(), which could trigger a spurious log message if they were already set to the desired values. This has been fixed. [GL #1042] [GL #1090]

(continues on next page)

(continued from previous page)

5393.	[cleanup]	Unused and/or redundant APIs were removed from libirs. [GL #1758]
5392.	[bug]	It was possible for named to crash during shutdown or reconfiguration if an RPZ zone was still being updated. [GL #1779]
5391.	[func]	The BIND 9 build system has been changed to use a typical autoconf+automake+libtool stack. When building from the Git repository, run "autoreconf -fi" first. [GL #4]
5390.	[security]	Replaying a TSIG BADTIME response as a request could trigger an assertion failure. (CVE-2020-8617) [GL #1703]
5389.	[bug]	Finish PKCS#11 code cleanup, fix a couple of smaller bugs and use PKCS#11 v3.0 EdDSA macros and constants. Thanks to Aaron Thompson. [GL !3391]
5388.	[func]	Reject AXFR streams where the message ID is not consistent. [GL #1674]
5387.	[placeholder]	
5386.	[cleanup]	Address Coverity warnings in lib/dns/keymgr.c. [GL #1737]
5385.	[func]	Make ISC rwlock implementation the default again. [GL #1753]
5384.	[bug]	With "dnssec-policy" in effect, "inline-signing" was implicitly set to "yes". Now "inline-signing" is only set to "yes" if the zone is not dynamic. [GL #1709]

--- 9.17.1 released ---		
5383.	[func]	Add a quota attach function with a callback and clean up the isc_quota API. [GL !3280]
5382.	[bug]	Use clock_gettime() instead of gettimeofday() for isc_stdtime() function. [GL #1679]
5381.	[bug]	Fix logging API data race by adding rwlock and caching logging levels in stdatomic variables to restore performance to original levels. [GL #1675] [GL #1717]
5380.	[contrib]	Fix building MySQL DLZ modules against MySQL 8 libraries. [GL #1678]
5379.	[placeholder]	

(continues on next page)

(continued from previous page)

- 5378. [bug] Receiving invalid DNS data was triggering an assertion failure in nslookup. [GL #1652]
- 5377. [placeholder]
- 5376. [bug] Fix ineffective DNS rebinding protection when BIND is configured as a forwarding DNS server. Thanks to Tobias Klein. [GL #1574]
- 5375. [test] Fix timing issues in the "kasp" system test. [GL #1669]
- 5374. [bug] Statistics counters tracking recursive clients and active connections could underflow. [GL #1087]
- 5373. [bug] Collecting statistics for DNSSEC signing operations (change 5254) caused an array of significant size (over 100 kB) to be allocated for each configured zone. Each of these arrays is tracking all possible key IDs; this could trigger an out-of-memory condition on servers with a high enough number of zones configured. Fixed by tracking up to four keys per zone and rotating counters when keys are replaced. This fixes the immediate problem of high memory usage, but should be improved in a future release by growing or shrinking the number of keys to track upon key rollover events. [GL #1179]
- 5372. [bug] Fix migration from existing DNSSEC key files ("auto-dnssec maintain") to "dnssec-policy". [GL #1706]
- 5371. [bug] Improve incremental updates of the RPZ summary database to reduce delays that could occur when a policy zone update included a large number of record deletions. [GL #1447]
- 5370. [bug] Deactivation of a netmgr handle associated with a socket could be skipped in some circumstances. Fixed by deactivating the netmgr handle before scheduling the asynchronous close routine. [GL #1700]
- 5369. [func] Add the ability to specify whether to wait for nameserver domain names to be looked up, with a new RPZ modifying directive 'nsdname-wait-recurse'. [GL #1138]
- 5368. [bug] Named failed to restart if 'rndc addzone' names contained special characters (e.g. '/'). [GL #1655]
- 5367. [placeholder]

--- 9.17.0 released ---

- 5366. [bug] Fix a race condition with the keymgr when the same

(continues on next page)

(continued from previous page)

		zone plus dnssec-policy is configured in multiple views. [GL #1653]
5365.	[bug]	Algorithm rollover was stuck on submitting DS because keymgr thought it would move to an invalid state. Fixed by checking the current key against the desired state, not the existing state. [GL #1626]
5364.	[bug]	Algorithm rollover waited too long before introducing zone signatures. It waited to make sure all signatures were regenerated, but when introducing a new algorithm, all signatures are regenerated immediately. Only add the sign delay if there is a predecessor key. [GL #1625]
5363.	[bug]	When changing a dnssec-policy, existing keys with properties that no longer match were not being retired. [GL #1624]
5362.	[func]	Limit the size of IXFR responses so that AXFR will be used instead if it would be smaller. This is controlled by the "max-ixfr-ratio" option, which is a percentage representing the ratio of IXFR size to the size of the entire zone. This value cannot exceed 100%, which is the default. [GL #1515]
5361.	[bug]	named might not accept new connections after hitting tcp-clients quota. [GL #1643]
5360.	[bug]	delv could fail to load trust anchors in DNSKEY format. [GL #1647]
5359.	[func]	"rndc nta -d" and "rndc secroots" now include "validate-except" entries when listing negative trust anchors. These are indicated by the keyword "permanent" in place of an expiry date. [GL #1532]
5358.	[bug]	Inline master zones whose master files were touched but otherwise unchanged and were subsequently reloaded may have stopped re-signing. [GL !3135]
5357.	[bug]	Newly added RRSIG records with expiry times before the previous earliest expiry times might not be re-signed in time. This was a side effect of 5315. [GL !3137]
5356.	[func]	Update dnssec-policy configuration statements: - Rename "zone-max-ttl" dnssec-policy option to "max-zone-ttl" for consistency with the existing zone option. - Allow for "lifetime unlimited" as a synonym for "lifetime PT0S".

(continues on next page)

(continued from previous page)

		<ul style="list-style-type: none"> <li>- Make "key-directory" optional.</li> <li>- Warn if specifying a key length does not make sense; fail if key length is out of range for the algorithm.</li> <li>- Allow use of mnemonics when specifying key algorithm (e.g. "rsasha256", "ecdsa384", etc.).</li> <li>- Make ISO 8601 durations case-insensitive.</li> </ul> <p>[GL #1598]</p>
5355.	[func]	What was set with --with-tuning=large option in older BIND9 versions is now a default, and a --with-tuning=small option was added for small (e.g. OpenWRT) systems. [GL !2989]
5354.	[bug]	dnssec-policy created new KSK keys for zones in the initial stage of signing (with the DS not yet in the rumoured or omnipresent states). Fix by checking the key goals rather than the active state when determining whether new keys are needed. [GL #1593]
5353.	[doc]	Document port and dscp parameters in forwarders configuration option. [GL #914]
5352.	[bug]	Correctly handle catalog zone entries containing characters that aren't legal in filenames. [GL #1592]
5351.	[bug]	CDS / CDNSKEY consistency checks failed to handle removal records. [GL #1554]
5350.	[bug]	When a view was configured with class CHAOS, the server could crash while processing a query for a non-existent record. [GL #1540]
5349.	[bug]	Fix a race in task_pause/unpause. [GL #1571]
5348.	[bug]	dnssec-settime -Psync was not being honoured. Thanks to Tony Finch. [GL !2893]

		--- 9.15.8 released ---
5347.	[bug]	Fixed a bug that could cause an intermittent crash in validator.c when validating a negative cache entry. [GL #1561]
5346.	[bug]	Make hazard pointer array allocations dynamic, fixing a bug that caused named to crash on machines with more than 40 cores. [GL #1493]
5345.	[func]	Key-style trust anchors and DS-style trust anchors can now both be used for the same name. [GL #1237]
5344.	[bug]	Handle accept() errors properly in netmgr. [GL !2880]

(continues on next page)

(continued from previous page)

- 5343. [func] Add statistics counters to the netmgr. [GL #1311]
- 5342. [bug] Disable pktinfo for IPv6 and bind to each interface explicitly instead, because libuv doesn't support pktinfo control messages. [GL #1558]
- 5341. [func] Simplify passing the bound TCP socket to child threads by using isc\_uv\_export/import functions. [GL !2825]
- 5340. [bug] Don't deadlock when binding to a TCP socket fails. [GL #1499]
- 5339. [bug] With some libmaxminddb versions, named could erroneously match an IP address not belonging to any subnet defined in a given GeoIP2 database to one of the existing entries in that database. [GL #1552]
- 5338. [bug] Fix line spacing in `rndc secroots`. Thanks to Tony Finch. [GL !2478]
- 5337. [func] 'named -V' now reports maxminddb and protobuf-c versions. [GL !2686]

--- 9.15.7 released ---

- 5336. [bug] The TCP high-water statistic could report an incorrect value on startup. [GL #1392]
- 5335. [func] Make TCP listening code multithreaded. [GL !2659]
- 5334. [doc] Update documentation with dnssec-policy clarifications. Also change some defaults. [GL !2711]
- 5333. [bug] Fix duration printing on Solaris when value is not an ISO 8601 duration. [GL #1460]
- 5332. [func] Renamed "dnssec-keys" configuration statement to the more descriptive "trust-anchors". [GL !2702]
- 5331. [func] Use compiler-provided mechanisms for thread local storage, and make the requirement for such mechanisms explicit in configure. [GL #1444]
- 5330. [bug] 'configure --without-python' was ineffective if PYTHON was set in the environment. [GL #1434]
- 5329. [bug] Reconfiguring named caused memory to be leaked when any GeoIP2 database was in use. [GL #1445]
- 5328. [bug] rbtodb.c:rdataset\_{get,set}ownercase failed to obtain

(continues on next page)

(continued from previous page)

		a node lock. [GL #1417]
5327.	[func]	Added a statistics counter to track queries dropped because the recursive-clients quota was exceeded. [GL #1399]
5326.	[bug]	Add Python dependency on 'distutils.core' to configure. 'distutils.core' is required for installation. [GL #1397]
5325.	[bug]	Addressed several issues with TCP connections in the netmgr: restored support for TCP connection timeouts, restored TCP backlog support, actively close all open sockets during shutdown. [GL #1312]
5324.	[bug]	Change the category of some log messages from general to the more appropriate category of xfer-in. [GL #1394]
5323.	[bug]	Fix a bug in DNSSEC trust anchor verification. [GL #2609]
5322.	[placeholder]	
5321.	[bug]	Obtain write lock before updating version->records and version->bytes. [GL #1341]
5320.	[cleanup]	Silence TSAN on header->count. [GL #1344]

		--- 9.15.6 released ---
5319.	[func]	Trust anchors can now be configured using DS format to represent a key digest, by using the new "initial-ds" or "static-ds" keywords in the "dnssec-keys" statement.  Note: DNSKEY-format and DS-format trust anchors cannot both be used for the same domain name. [GL #622]
5318.	[cleanup]	The DNSSEC validation code has been refactored for clarity and to reduce code duplication. [GL #622]
5317.	[func]	A new asynchronous network communications system based on libuv is now used for listening for incoming requests and responding to them. (The old isc_socket API remains in use for sending iterative queries and processing responses; this will be changed too in a later release.)  This change will make it easier to improve performance and implement new protocol layers

(continues on next page)

(continued from previous page)

		(e.g., DNS over TLS) in the future. [GL #29]
5316.	[func]	A new "dnssec-policy" option has been added to named.conf to implement a key and signing policy (KASP) for zones. When this option is in use, named can generate new keys as needed and automatically roll both ZSK and KSK keys. (Note that the syntax for this statement differs from the dnssec policy used by dnssec-keymgr.)  See the ARM for configuration details. [GL #1134]
5315.	[bug]	Apply the initial RRSIG expiration spread fixed to all dynamically created records in the zone including NSEC3. Also fix the signature clusters when the server has been offline for prolonged period of times. [GL #1256]
5314.	[func]	Added a new statistics variable "tcp-highwater" that reports the maximum number of simultaneous TCP clients BIND has handled while running. [GL #1206]
5313.	[bug]	The default GeoIP2 database location did not match the ARM. 'named -V' now reports the default location. [GL #1301]
5312.	[bug]	Do not flush the cache for `rndc validation status`. Thanks to Tony Finch. [GL !2462]
5311.	[cleanup]	Include all views in output of `rndc validation status`. Thanks to Tony Finch. [GL !2461]
5310.	[bug]	TCP failures were affecting EDNS statistics. [GL #1059]
5309.	[placeholder]	
5308.	[bug]	Don't log DNS_R_UNCHANGED from sync_secure_journal() at ERROR level in receive_secure_serial(). [GL #1288]
5307.	[bug]	Fix hang when named-compilezone output is sent to pipe. Thanks to Tony Finch. [GL !2481]
5306.	[security]	Set a limit on number of simultaneous pipelined TCP queries. (CVE-2019-6477) [GL #1264]
5305.	[bug]	NSEC Aggressive Cache ("synth-from-dnssec") has been disabled by default because it was found to have a significant performance impact on the recursive service. [GL #1265]
5304.	[bug]	"dnskey-sig-validity 0;" was not being accepted. [GL #876]

(continues on next page)

(continued from previous page)

- 5303. [placeholder]
- 5302. [bug] Fix checking that "dnstap-output" is defined when "dnstap" is specified in a view. [GL #1281]
- 5301. [bug] Detect partial prefixes / incomplete IPv4 address in acls. [GL #1143]
- 5300. [bug] dig/mdig/delv: Add a colon after EDNS option names, even when the option is empty, to improve readability and allow correct parsing of YAML output. [GL #1226]

--- 9.15.5 released ---

- 5299. [security] A flaw in DNSSEC verification when transferring mirror zones could allow data to be incorrectly marked valid. (CVE-2019-6475) [GL #1252]
- 5298. [security] Named could assert if a forwarder returned a referral, rather than resolving the query, when QNAME minimization was enabled. (CVE-2019-6476) [GL #1051]
- 5297. [bug] Check whether a previous QNAME minimization fetch is still running before starting a new one; return SERVFAIL and log an error if so. [GL #1191]
- 5296. [placeholder]
- 5295. [cleanup] Split dns\_name\_copy() calls into dns\_name\_copy() and dns\_name\_copynf() for those calls that can potentially fail and those that should not fail respectively. [GL #12265]
- 5294. [func] Fallback to ACE name on output in locale, which does not support converting it to unicode. [GL #846]
- 5293. [bug] On Windows, named crashed upon any attempt to fetch XML statistics from it. [GL #1245]
- 5292. [bug] Queue 'rndc nsec3param' requests while signing inline zone changes. [GL #1205]

--- 9.15.4 released ---

- 5291. [placeholder]
- 5290. [placeholder]
- 5289. [bug] Address NULL pointer dereference in rpz.c:rpz\_detach.

(continues on next page)

(continued from previous page)

		[GL #1210]
5288.	[bug]	dnssec-must-be-secure was not always honored. [GL #1209]
5287.	[placeholder]	
5286.	[contrib]	Address potential NULL pointer dereferences in dlz_mysql_dyn_mod.c. [GL #1207]
5285.	[port]	win32: implement "-T maxudpXXX". [GL #837]
5284.	[func]	Added +unexpected command line option to dig. By default, dig won't accept a reply from a source other than the one to which it sent the query. Invoking dig with +unexpected argument will allow it to process replies from unexpected sources.
5283.	[bug]	When a response-policy zone expires, ensure that its policies are removed from the RPZ summary database. [GL #1146]
5282.	[bug]	Fixed a bug in searching for possible wildcard matches for query names in the RPZ summary database. [GL #1146]
5281.	[cleanup]	Don't escape commas when reporting named's command line. [GL #1189]
5280.	[protocol]	Add support for displaying EDNS option LLQ. [GL #1201]
5279.	[bug]	When loading, reject zones containing CDS or CDNSKEY RRsets at the zone apex if they would cause DNSSEC validation failures if published in the parent zone as the DS RRset. [GL #1187]
5278.	[func]	Add YAML output formats for dig, mdig and delv; use the "+yaml" option to enable. [GL #1145]

		--- 9.15.3 released ---
5277.	[bug]	Cache DB statistics could underflow when serve-stale was in use, because of a bug in counter maintenance when RRsets become stale.  Functions for dumping statistics have been updated to dump active, stale, and ancient statistic counters. Ancient RRset counters are prefixed with '~'; stale RRset counters are still prefixed with '#'. [GL #602]
5276.	[func]	DNSSEC Lookaside Validation (DLV) is now obsolete; all code enabling its use has been removed from the

(continues on next page)

(continued from previous page)

		validator, "delv", and the DNSSEC tools. [GL #7]
5275.	[bug]	Mark DS records included in referral messages with trust level "pending" so that they can be validated and cached immediately, with no need to re-query. [GL #964]
5274.	[bug]	Address potential use after free race when shutting down rpz. [GL #1175]
5273.	[bug]	Check that bits [64..71] of a dns64 prefix are zero. [GL #1159]
5272.	[cleanup]	Remove isc-config.sh script as the BIND 9 libraries are now purely internal. [GL #1123]
5271.	[func]	The normal (non-debugging) output of dnssec-signzone and dnssec-verify tools now goes to stdout, instead of the combination of stderr and stdout.
5270.	[bug]	'dig +expandaaaa +short' did not work. [GL #1152]
5269.	[port]	cygwin: can return ETIMEDOUT on connect() with a non-blocking socket. [GL #1133]
5268.	[placeholder]	
5267.	[func]	Allow statistics groups display to be toggle-able. [GL #1030]
5266.	[bug]	named-checkconf failed to report dnstap-output missing from named.conf when dnstap was specified. [GL #1136]
5265.	[bug]	DNS64 and RPZ nodata (CNAME *.) rules interacted badly [GL #1106]
5264.	[func]	New DNS Cookie algorithm - siphash24 - has been added to BIND 9, and the old HMAC-SHA DNS Cookie algorithms have been removed. [GL #605]

		--- 9.15.2 released ---
5263.	[cleanup]	Use atomics and isc_refcount_t wherever possible. [GL #1038]
5262.	[func]	Removed support for the legacy GeoIP API. [GL #1112]
5261.	[cleanup]	Remove SO_BSDCOMPAT socket option usage.
5260.	[bug]	dnstap-read was producing malformed output for large packets. [GL #1093]

(continues on next page)

(continued from previous page)

- 5259. [func] New option '-i' for 'named-checkconf' to ignore warnings about deprecated options. [GL #1101]
- 5258. [func] Added support for the GeoIP2 API from MaxMind. This will be compiled in by default if the "libmaxminddb" library is found at compile time, but can be suppressed using "configure --disable-geoip".  
  
Certain geoip ACL settings that were available with legacy GeoIP are not available when using GeoIP2. [GL #182]
- 5257. [bug] Some statistics data was not being displayed. Add shading to the zone tables. [GL #1030]
- 5256. [bug] Ensure that glue records are included in root priming responses if "minimal-responses" is not set to "yes". [GL #1092]
- 5255. [bug] Errors encountered while reloading inline-signing zones could be ignored, causing the zone content to be left in an incompletely updated state rather than reverted. [GL #1109]
- 5254. [func] Collect metrics to report to the statistics-channel DNSSEC signing operations (dnssec-sign) and refresh operations (dnssec-refresh) per zone and per keytag. [GL #513]
- 5253. [port] Support platforms that don't define ULLONG\_MAX. [GL #1098]
- 5252. [func] Report if the last 'rndc reload/reconfig' failed in rndc status. [GL #2040]
- 5251. [bug] Statistics were broken in x86 Windows builds. [GL #1081]
- 5250. [func] The default size for RSA keys is now 2048 bits, for both ZSKs and KSKs. [GL #1097]
- 5249. [bug] Fix a possible underflow in recursion clients statistics when hitting recursive clients soft quota. [GL #1067]

--- 9.15.1 released ---

- 5248. [func] To clarify the configuration of DNSSEC keys, the "managed-keys" and "trusted-keys" options have both been deprecated. The new "dnssec-keys" statement can now be used for all trust anchors,

(continues on next page)

(continued from previous page)

		with the keywords "initial-key" or "static-key" to indicate whether the configured trust anchor should be used for initialization of RFC 5011 key management, or as a permanent trust anchor.
		The "static-key" keyword will generate a warning if used for the root zone.
		Configurations using "trusted-keys" or "managed-keys" will continue to work with no changes, but will generate warnings in the log. In a future release, these options will be marked obsolete. [GL #6]
5247.	[cleanup]	The 'cleaning-interval' option has been removed. [GL #1731]
5246.	[func]	Log TSIG if appropriate in 'sending notify to' message. [GL #1058]
5245.	[cleanup]	Reduce logging level for IXFR up-to-date poll responses. [GL #1009]
5244.	[security]	Fixed a race condition in dns_dispatch_getnext() that could cause an assertion failure if a significant number of incoming packets were rejected. (CVE-2019-6471) [GL #942]
5243.	[bug]	Fix a possible race between dispatcher and socket code in a high-load cold-cache resolver scenario. [GL #943]
5242.	[bug]	In relaxed qname minimization mode, fall back to normal resolution when encountering a lame delegation, and use <code>_.domain/A</code> queries rather than <code>domain/NS</code> . [GL #1055]
5241.	[bug]	Fix Ed448 private and public key ASN.1 prefix blobs. [GL #225]
5240.	[bug]	Remove key id calculation for RSAMD5. [GL #996]
5239.	[func]	Change the json-c detection to pkg-config. [GL #855]
5238.	[bug]	Fix a possible deadlock in TCP code. [GL #1046]
5237.	[bug]	Recurse to find the root server list with 'dig +trace'. [GL #1028]
5236.	[func]	Add SipHash 2-4 implementation in lib/isc/siphash.c and switch <code>isc_hash_function()</code> to use SipHash 2-4. [GL #605]

(continues on next page)

(continued from previous page)

5235.	[cleanup]	Refactor lib/isc/app.c to be thread-safe, unused parts of the API has been removed and the isc_appctx_t data type has been changed to be fully opaque. [GL #1023]
5234.	[port]	arm: just use the compiler's default support for yield. [GL #981]

--- 9.15.0 released ---		
5233.	[bug]	Negative trust anchors did not work with "forward only;" to validating resolvers. [GL #997]
5232.	[placeholder]	
5231.	[protocol]	Add support for displaying CLIENT-TAG and SERVER-TAG. [GL #960]
5230.	[protocol]	The SHA-1 hash algorithm is no longer used when generating DS and CDS records. [GL #1015]
5229.	[protocol]	Enforce known SSHFP fingerprint lengths. [GL #852]
5228.	[func]	If trusted-keys and managed-keys were configured simultaneously for the same name, the key could not be rolled automatically. This is now a fatal configuration error. [GL #868]
5227.	[placeholder]	
5226.	[placeholder]	
5225.	[func]	Allow dig to print out AAAA record fully expanded. with +[no]expandaaaa. [GL #765]
5224.	[bug]	Only test provide-ixfr on TCP streams. [GL #991]
5223.	[bug]	Fixed a race in the filter-aaaa plugin accessing the hash table. [GL #1005]
5222.	[bug]	'delv -t ANY' could leak memory. [GL #983]
5221.	[test]	Enable parallel execution of system tests on Windows. [GL #4101]
5220.	[cleanup]	Refactor the isc_stat structure to take advantage of stdatomic. [GL #1493]
5219.	[bug]	Fixed a race in the filter-aaaa plugin that could trigger a crash when returning an instance object to the memory pool. [GL #982]

(continues on next page)

(continued from previous page)

5218.	[bug]	Conditionally include <dlfcn.h>. [GL #995]
5217.	[bug]	Restore key id calculation for RSAMD5. [GL #996]
5216.	[bug]	Fetches-per-zone counter wasn't updated correctly when doing qname minimization. [GL #992]
5215.	[bug]	Change #5124 was incomplete; named could still return FORMERR instead of SERVFAIL in some cases. [GL #990]
5214.	[bug]	win32: named now removes its lock file upon shutdown. [GL #979]
5213.	[bug]	win32: Eliminated a race which allowed named.exe running as a service to be killed prematurely during shutdown. [GL #978]
5212.	[placeholder]	
5211.	[bug]	Allow out-of-zone additional data to be included in authoritative responses if recursion is allowed and "minimal-responses" is disabled. This behavior was inadvertently removed in change #4605. [GL #817]
5210.	[bug]	When dnstap is enabled and recursion is not available, incoming queries are now logged as "auth". Previously, this depended on whether recursion was requested by the client, not on whether recursion was available. [GL #963]
5209.	[bug]	When update-check-ksk is true, add_sigs was not considering offline keys, leaving record sets signed with the incorrect type key. [GL #763]
5208.	[test]	Run valid rdata wire encodings through totext+fromtext and tofmttext+fromtext methods to check these methods. [GL #899]
5207.	[test]	Check delv and dig TTL values. [GL #965]
5206.	[bug]	Delv could print out bad TTLs. [GL #965]
5205.	[bug]	Enforce that a DS hash exists. [GL #899]
5204.	[test]	Check that dns_rdata_fromtext() produces a record that will be accepted by dns_rdata_fromwire(). [GL #852]
5203.	[bug]	Enforce whether key rdata exists or not in KEY, DNSKEY, CDNSKEY and RKEY. [GL #899]
5202.	[bug]	<dns/ecs.h> was missing ISC_LANG_ENDDECLS. [GL #976]

(continues on next page)

(continued from previous page)

- 5201. [bug] Fix a possible deadlock in RPZ update code. [GL #973]
- 5200. [security] tcp-clients settings could be exceeded in some cases, which could lead to exhaustion of file descriptors. (CVE-2018-5743) [GL #615]
- 5199. [security] In certain configurations, named could crash if nxdomain-redirect was in use and a redirected query resulted in an NXDOMAIN from the cache. (CVE-2019-6467) [GL #880]
- 5198. [bug] If a fetch context was being shut down and, at the same time, we returned from qname minimization, an INSIST could be hit. [GL #966]
- 5197. [bug] dig could die in best effort mode on multiple SIG(0) records. Similarly on multiple OPT and multiple TSIG records. [GL #920]
- 5196. [bug] make install failed with --with-dlopen=no. [GL #955]
- 5195. [bug] "allow-update" and "allow-update-forwarding" were treated as configuration errors if used at the options or view level. [GL #913]
- 5194. [bug] Enforce non empty ZOMEMD hash. [GL #899]
- 5193. [bug] EID and NIMLOC failed to do multi-line output correctly. [GL #899]
- 5192. [placeholder]
- 5191. [placeholder]
- 5190. [bug] Ignore trust anchors using disabled algorithms. [GL #806]
- 5189. [cleanup] Remove revoked root DNSKEY from bind.keys. [GL #945]
- 5188. [func] The "dnssec-enable" option is deprecated and no longer has any effect; DNSSEC responses are always enabled. [GL #866]
- 5187. [test] Set time zone before running any tests in dnstap\_test. [GL #940]
- 5186. [cleanup] More dnssec-keygen manual tidying. [GL !1678]
- 5185. [placeholder]
- 5184. [bug] Missing unlocks in sdlz.c. [GL #936]

(continues on next page)

(continued from previous page)

- 5183. [bug] Reinitialize ECS data before reusing client structures. [GL #881]
- 5182. [bug] Fix a high-load race/crash in handling of `isc_socket_close()` in resolver. [GL #834]
- 5181. [func] Add a mechanism for a DLZ module to signal that the view's allow-transfer ACL should be used to determine whether transfers are allowed. [GL #803]
- 5180. [bug] `delv` now honors the operating system's preferred ephemeral port range. [GL #925]
- 5179. [cleanup] Replace some vague type declarations with the more specific `dns_secalg_t` and `dns_dsdigest_t`. Thanks to Tony Finch. [GL !1498]
- 5178. [bug] Handle EDQUOT (disk quota) and ENOSPC (disk full) errors when writing files. [GL #902]
- 5177. [func] Add the ability to specify in `named.conf` whether a response-policy zone's SOA record should be added to the additional section (`add-soa yes/no`). [GL #865]
- 5176. [tests] Remove a dependency on `libxml` in `statschannel` system test. [GL #926]
- 5175. [bug] Fixed a problem with file input in `dnssec-keymgr`, `dnssec-coverage` and `dnssec-checkds` when using `python3`. [GL #882]
- 5174. [doc] Tidy `dnssec-keygen` manual. [GL !1557]
- 5173. [bug] Fixed a race in socket code that could occur when `accept`, `send`, or `recv` were called from an event loop but the socket had been closed by another thread. [RT #874]
- 5172. [bug] `nsupdate` now honors the operating system's preferred ephemeral port range. [GL #905]
- 5171. [func] `named` plugins are now installed into a separate directory. Supplying a filename (a string without path separators) in a "plugin" configuration stanza now causes `named` to look for that plugin in that directory. [GL #878]
- 5170. [test] Added `--with-dlz-filesystem` to `feature-test`. [GL !1587]
- 5169. [bug] The presence of certain types in an otherwise empty node could cause a crash while processing a

(continues on next page)

(continued from previous page)

		type ANY query. [GL #901]
5168.	[bug]	Do not crash on shutdown when RPZ fails to load. Also, keep previous version of the database if RPZ fails to load. [GL #813]
5167.	[bug]	nxdomain-redirect could sometimes lookup the wrong redirect name. [GL #892]
5166.	[placeholder]	
5165.	[contrib]	Removed SDB drivers from contrib; they're obsolete. [GL #428]
5164.	[bug]	Correct errno to result translation in dlz filesystem modules. [GL #884]
5163.	[cleanup]	Out-of-tree builds failed --enable-dnstap. [GL #836]
5162.	[cleanup]	Improve dnssec-keymgr manual. Thanks to Tony Finch. [GL !1518]
5161.	[bug]	Do not require the SEP bit to be set for mirror zone trust anchors. [GL #873]
5160.	[contrib]	Added DNAME support to the DLZ LDAP schema. Also fixed a compilation bug affecting several DLZ modules. [GL #872]
5159.	[bug]	dnssec-coverage was incorrectly ignoring names specified on the command line without trailing dots. [GL !1478]
5158.	[protocol]	Add support for AMTRELAY and ZONEMD. [GL #867]
5157.	[bug]	Nslookup now errors out if there are extra command line arguments. [GL #207]
5156.	[doc]	Extended and refined the section of the ARM describing mirror zones. [GL #774]
5155.	[func]	"named -V" now outputs the default paths to named.conf, rndc.conf, bind.keys, and other files used or created by named and other tools, so that the correct paths to these files can quickly be determined regardless of the configure settings used when BIND was built. [GL #859]
5154.	[bug]	dig: process_opt could be called twice on the same message leading to a assertion failure. [GL #860]
5153.	[func]	Zone transfer statistics (size, number of records, and

(continues on next page)

(continued from previous page)

		number of messages) are now logged for outgoing transfers as well as incoming ones. [GL #513]
5152.	[func]	Improved logging of DNSSEC key events: - Zone signing and DNSKEY maintenance events are now logged to the "dnssec" category - Messages are now logged when DNSSEC keys are published, activated, inactivated, deleted, or revoked. [GL #714]
5151.	[func]	Options that have been been marked as obsolete in named.conf for a very long time are now fatal configuration errors. [GL #358]
5150.	[cleanup]	Remove the ability to compile BIND with assertions disabled. [GL #735]
5149.	[func]	"rndc dumpdb" now prints a line above a stale RRset indicating how long the data will be retained in the cache for emergency use. [GL #101]
5148.	[bug]	named did not sign the TKEY response. [GL #821]
5147.	[bug]	dnssec-keymgr: Add a five-minute margin to better handle key events close to 'now'. [GL #848]
5146.	[placeholder]	
5145.	[func]	Use atomics instead of locked variables for isc_quota and isc_counter. [GL !1389]
5144.	[bug]	dig now returns a non-zero exit code when a TCP connection is prematurely closed by a peer more than once for the same lookup. [GL #820]
5143.	[bug]	dnssec-keymgr and dnssec-coverage failed to find key files for zone names ending in ".". [GL #560]
5142.	[cleanup]	Removed "configure --disable-rpz-nsip" and "--disable-rpz-nsdname" options. "nsip-enable" and "nsdname-enable" both now default to yes, regardless of compile-time settings. [GL #824]
5141.	[security]	Zone transfer controls for writable DLZ zones were not effective as the allowzonexfr method was not being called for such zones. (CVE-2019-6465) [GL #790]
5140.	[bug]	Don't immediately mark existing keys as inactive and deleted when running dnssec-keymgr for the first time. [GL #117]

(continues on next page)

(continued from previous page)

- 5139. [bug] If possible, don't use forwarders when priming. This ensures we can get root server IP addresses from priming query response glue, which may not be present if the forwarding server is returning minimal responses. [GL #752]
- 5138. [bug] Under some circumstances named could hit an assertion failure when doing qname minimization when using forwarders. [GL #797]
- 5137. [func] named now logs messages whenever a mirror zone becomes usable or unusable for resolution purposes. [GL #818]
- 5136. [cleanup] Check in named-checkconf that allow-update and allow-update-forwarding are not set at the view/options level; fix documentation. [GL #512]
- 5135. [port] sparc: Use smt\_pause() instead of pause. [GL #816]
- 5134. [bug] win32: WSASStartup was not called before getservbyname was called. [GL #590]
- 5133. [bug] 'rndc managed-keys' didn't handle class and view correctly and failed to add new lines between each view. [GL !1327]
- 5132. [bug] Fix race condition in cleanup part of dns\_dt\_create(). [GL !1323]
- 5131. [cleanup] Address Coverity warnings. [GL #801]
- 5130. [cleanup] Remove support for l10n message catalogs. [GL #709]
- 5129. [contrib] sdlz\_helper.c:build\_querylist was not properly splitting the query string. [GL #798]
- 5128. [bug] Refreshkeytime was not being updated for managed keys zones. [GL #784]
- 5127. [bug] rcode.c:maybe\_numeric failed to handle NUL in text regions. [GL #807]
- 5126. [bug] Named incorrectly accepted empty base64 and hex encoded fields when reading master files. [GL #807]
- 5125. [bug] Allow for up to 100 records or 64k of data when caching a negative response. [GL #804]
- 5124. [bug] Named could incorrectly return FORMERR rather than SERVFAIL. [GL #804]
- 5123. [bug] dig could hang indefinitely after encountering an error

(continues on next page)

(continued from previous page)

		before creating a TCP socket. [GL #692]
5122.	[bug]	In a "forward first;" configuration, a forwarder timeout did not prevent that forwarder from being queried again after falling back to full recursive resolution. [GL #315]
5121.	[contrib]	dlz_stub_driver.c fails to return ISC_R_NOTFOUND on none matching zone names. [GL !1299]
5120.	[placeholder]	
5119.	[placeholder]	
5118.	[security]	Named could crash if it is managing a key with `managed-keys` and the authoritative zone is rolling the key to an unsupported algorithm. (CVE-2018-5745) [GL #780]
5117.	[placeholder]	
5116.	[bug]	Named/named-checkconf triggered a assertion when a mirror zone's name is bad. [GL #778]
5115.	[bug]	Allow unsupported algorithms in zone when not used for signing with dnssec-signzone. [GL #783]
5114.	[func]	Include a 'reconfig/reload in progress' status line in rndc status, use it in tests.
5113.	[port]	Fixed a Windows build error.
5112.	[bug]	Named/named-checkconf could dump core if there was a missing masters clause and a bad notify clause. [GL #779]
5111.	[bug]	Occluded DNSKEY records could make it into the delegating NSEC/NSEC3 bitmap. [GL #742]
5110.	[security]	Named leaked memory if there were multiple Key Tag EDNS options present. (CVE-2018-5744) [GL #772]
5109.	[cleanup]	Remove support for RSAMD5 algorithm. [GL #628]

--- 9.13.5 released ---

5108.	[bug]	Named could fail to determine bottom of zone when removing out of date keys leading to invalid NSEC and NSEC3 records being added to the zone. [GL #771]
5107.	[bug]	'host -U' did not work. [GL #769]

(continues on next page)

(continued from previous page)

- 5106. [experimental] A new "plugin" mechanism has been added to allow extension of query processing functionality through the use of dynamically loadable libraries. A "filter-aaaa.so" plugin has been implemented, replacing the filter-aaaa feature that was formerly implemented as a native part of BIND.  
  
The "filter-aaaa", "filter-aaaa-on-v4" and "filter-aaaa-on-v6" options can no longer be configured using native named.conf syntax. However, loading the filter-aaaa.so plugin and setting its parameters provides identical functionality.  
  
Note that the plugin API is a work in progress and is likely to evolve as further plugins are implemented. [GL #15]
- 5105. [bug] Fix a race between process\_fd and socketclose in unix socket code. [GL #744]
- 5104. [cleanup] Log clearer informational message when a catz zone is overridden by a zone in named.conf. Thanks to Tony Finch. [GL !1157]
- 5103. [bug] Add missing design by contract tests to dns\_catz\*. [GL #748]
- 5102. [bug] dnssec-coverage failed to use the default TTL when checking KSK deletion times leading to a exception. [GL #585]
- 5101. [bug] Fix default installation path for Python modules and remove the dnspython dependency accidentally introduced by change 4970. [GL #730]
- 5100. [func] Pin resolver tasks to specific task queues. [GL !1117]
- 5099. [func] Failed mutex and conditional creations are always fatal. [GL #674]

--- 9.13.4 released ---

- 5098. [func] Failed memory allocations are now fatal. [GL #674]
- 5097. [cleanup] Remove embedded ATF unit testing framework from BIND source distribution. [GL !875]
- 5096. [func] Use multiple event loops in socket code, and make network threads CPU-affinitive. This significantly improves performance on large systems. [GL #666]

(continues on next page)

(continued from previous page)

- 5095. [test]           Converted all unit tests from ATF to CMocka;  
removed the source code for the ATF libraries.  
Build with "configure --with-cmocka" to enable  
unit testing. [GL #620]
- 5094. [func]           Add 'dig -r' to disable reading of .digrc. [GL !970]
- 5093. [bug]           Log lame qname-minimization servers only if they're  
really lame. [GL #671]
- 5092. [bug]           Address memory leak on SIGTERM in nsupdate when using  
GSS-TSIG. [GL #558]
- 5091. [func]           Two new global and per-view options min-cache-ttl  
and min-ncache-ttl [GL #613]
- 5090. [bug]           dig and mdig failed to properly pre-parse dash value  
pairs when value was a separate argument and started  
with a dash. [GL #584]
- 5089. [bug]           Restore localhost fallback in dig and host which is  
used when no nameserver addresses present in  
/etc/resolv.conf are usable due to the requested  
address family restrictions. [GL #433]
- 5088. [bug]           dig/host/nslookup could crash when interrupted close to  
a query timeout. [GL #599]
- 5087. [test]           Check that result tables are complete. [GL #676]
- 5086. [func]           Log of RPZ now includes the QTYPE and QCLASS. [GL #623]
- 5085. [bug]           win32: Restore looking up nameservers, search list,  
etc. [GL #186]
- 5084. [placeholder]
- 5083. [func]           Add autoconf macro AX\_POSIX\_SHELL, so we  
can use POSIX-compatible shell features  
in the scripts.
- 5082. [bug]           Fixed a race that could cause a crash in  
dig/host/nslookup. [GL #650]
- 5081. [func]           Use per-worker queues in task manager, make task  
runners CPU-affine. [GL #659]
- 5080. [func]           Improvements to "rndc nta" user interface:
  - catch and report invalid command line options
  - when removing an NTA from all views, do not  
abort with an error if the NTA was not found  
in one of the views

(continues on next page)

(continued from previous page)

		- include the view name in "rndc nta -dump" output, for consistency with the add and remove actions Thanks to Tony Finch. [GL !816]
5079.	[func]	Disable IDN processing in dig and nslookup when not on a tty. [GL #653]
5078.	[cleanup]	Require python components to be explicitly disabled if python is not available on unix platforms. [GL #601]
5077.	[cleanup]	Remove ip6.int support (-i) from dig and mdig. [GL !969]
5076.	[bug]	"require-server-cookie" was not effective if "rate-limit" was configured. [GL #617]
5075.	[bug]	Refresh nameservers from cache when sending final query in qname minimization. [GL #16]
5074.	[cleanup]	Remove vector socket functions - isc_socket_recvv(), isc_socket_sendtov(), isc_socket_sendtov2(), isc_socket_sendv() - in order to simplify socket code. [GL #645]
5073.	[bug]	Destroy a task first when destroying rpzs and catzs. [GL #84]
5072.	[bug]	Add unit tests for isc_buffer_copyregion() and fix its behavior for auto-reallocated buffers. [GL #644]
5071.	[bug]	Comparison of NXT records was broken. [GL #631]
5070.	[bug]	Record types which support a empty rdata field were not handling the empty rdata field case. [GL #638]
5069.	[bug]	Fix a hang on in RPZ when named is shutdown during RPZ zone update. [GL !907]
5068.	[bug]	Fix a race in RPZ with min-update-interval set to 0. [GL #643]
5067.	[bug]	Don't minimize qname when sending the query to a forwarder. [GL #361]
5066.	[cleanup]	Allow unquoted strings to be used as a zone names in response-policy statements. [GL #641]
5065.	[bug]	Only set IPV6_USE_MIN_MTU on IPv6. [GL #553]
5064.	[test]	Initialize TZ environment variable before calling dns_test_begin in dnstap_test. [GL #624]

(continues on next page)

(continued from previous page)

- 5063. [test] In statschannel test try a few times before failing when checking if the compressed output is the same as uncompressed. [GL !909]
- 5062. [func] Use non-crypto-secure PRNG to generate nonces for cookies. [GL !887]
- 5061. [protocol] Add support for EID and NIMLOC. [GL #626]
- 5060. [bug] GID, UID and UINFO could not be loaded using unknown record format. [GL #627]
- 5059. [bug] Display a per-view list of zones in the web interface. [GL #427]
- 5058. [func] Replace old message digest and hmac APIs with more generic isc\_md and isc\_hmac APIs, and convert their respective tests to cmocka. [GL #305]
- 5057. [protocol] Add support for ATMA. [GL #619]
- 5056. [placeholder]
- 5055. [func] A default list of primary servers for the root zone is now built into named, allowing the "masters" statement to be omitted when configuring an IANA root zone mirror. [GL #564]
- 5054. [func] Attempts to use mirror zones with recursion disabled are now considered a configuration error. [GL #564]
- 5053. [func] The only valid zone-level NOTIFY settings for mirror zones are now "notify no;" and "notify explicit;". [GL #564]
- 5052. [func] Mirror zones are now configured using "type mirror;" rather than "mirror yes;". [GL #564]
- 5051. [doc] Documentation incorrectly stated that the "server-addresses" static-stub zone option accepts custom port numbers. [GL #582]
- 5050. [bug] The libirs version of getaddrinfo() was unable to parse scoped IPv6 addresses present in /etc/resolv.conf. [GL #187]
- 5049. [cleanup] QNAME minimization has been deeply refactored. [GL #16]
- 5048. [func] Add configure option to enable and enforce FIPS mode in BIND 9. [GL #506]

(continues on next page)

(continued from previous page)

- 5047. [bug] Messages logged for certain query processing failures now include a more specific error description if it is available. [GL #572]
- 5046. [bug] named could crash during shutdown if an RPZ reload was in progress. [RT #46210]
- 5045. [func] Remove support for DNSSEC algorithms 3 (DSA) and 6 (DSA-NSEC3-SHA1). [GL #22]
- 5044. [cleanup] If "dnssec-enable" is no, then "dnssec-validation" now also defaults to no. [GL #388]
- 5043. [bug] Fix creating and validating EdDSA signatures. [GL #579]
- 5042. [test] Make the chained delegations in reclimit behave like they would in a regular name server. [GL #578]
- 5041. [test] The chain test contains a incomplete delegation. [GL #568]
- 5040. [func] Extended dnstap so that it can log UPDATE requests and responses as separate message types. Thanks to Greg Rabil. [GL #570]
- 5039. [bug] Named could fail to preserve owner name case of new RRset. [GL #420]
- 5038. [bug] Chaosnet addresses were compared incorrectly. [GL #562]
- 5037. [func] "allow-recursion-on" and "allow-query-cache-on" each now default to the other if only one of them is set, in order to be more consistent with the way "allow-recursion" and "allow-query-cache" work. Also we now ensure that both query-cache ACLs are checked when determining cache access. [GL #319]
- 5036. [cleanup] Fixed a spacing/formatting error in some RPZ-related error messages in the log. [GL #805]
- 5035. [test] Fixed errors that prevented the DNSRPS subtests from running in the rpz and rpzrecurse system tests. [GL #503]
- 5034. [bug] A race between threads could prevent zone maintenance scheduled immediately after zone load from being performed. [GL #542]
- 5033. [bug] When adding NTAs to multiple views using "rndc nta", the text returned via rndc was incorrectly terminated after the first line, making it look as if only one

(continues on next page)

(continued from previous page)

		NTA had been added. Also, it was not possible to differentiate between views with the same name but different classes; this has been corrected with the addition of a "-class" option. [GL #105]
5032.	[func]	Add krb5-selfsub and ms-selfsub update policy rules. [GL #511]
5031.	[cleanup]	Various defines in platform.h has been either dropped if always or never triggered on supported platforms or replaced with config.h equivalents if the defines didn't have any impact on public headers. Workarounds for LinuxThreads have been removed because NPTL is available since Linux kernel 2.6.0. [GL #525]
5030.	[bug]	Align CMSG buffers to a 64-bit boundary, fixes crash on architectures with strict alignment. [GL #521]

		--- 9.13.3 released ---
5029.	[func]	Workarounds for servers that misbehave when queried with EDNS have been removed, because these broken servers and the workarounds for their noncompliance cause unnecessary delays, increase code complexity, and prevent deployment of new DNS features. See <a href="https://dnsflagday.net">https://dnsflagday.net</a> for further details. [GL #150]
5028.	[bug]	Spread the initial RRSIG expiration times over the entire working sig-validity-interval when signing a zone in named to even out re-signing and transfer loads. [GL #418]
5027.	[func]	Set SO_SNDBUF size on sockets. [GL #74]
5026.	[bug]	rndc reconfig should not touch already loaded zones. [GL #276]
5025.	[cleanup]	Remove isc_keyboard family of functions. [GL #178]
5024.	[func]	Replace custom assembly for atomic operations with atomic support from the compiler. The code will now use C11 stdatomic, or __atomic, or __sync builtins with GCC or Clang compilers, and Interlocked functions with MSVC. [GL #10]
5023.	[cleanup]	Remove wrappers that try to fix broken or incomplete implementations of IPv6, pthreads and other core functionality required and used by BIND. [GL #192]
5022.	[doc]	Update ms-self, ms-subdomain, krb5-self, and krb5-subdomain documentation. [GL #708]

(continues on next page)

(continued from previous page)

- 5021. [bug] dig returned a non-zero exit code when it received a reply over TCP after a retry. [GL #487]
- 5020. [func] RNG uses thread-local storage instead of locks, if supported by platform. [GL #496]
- 5019. [cleanup] A message is now logged when ixfr-from-differences is set at zone level for an inline-signed zone. [GL #470]
- 5018. [bug] Fix incorrect sizeof arguments in lib/isc/pk11.c. [GL !588]
- 5017. [bug] lib/isc/pk11.c failed to unlink the session before releasing the lock which is unsafe. [GL !589]
- 5016. [bug] Named could assert with overlapping filter-aaaa and dns64 acls. [GL #445]
- 5015. [bug] Reloading all zones caused zone maintenance to cease for inline-signed zones. [GL #435]
- 5014. [bug] Signatures loaded from the journal for the signed version of an inline-signed zone were not scheduled for refresh. [GL #482]
- 5013. [bug] A referral response with a non-empty ANSWER section was inadvertently being treated as an error. [GL #390]
- 5012. [bug] Fix lock order reversal in pk11\_initialize. [GL !590]
- 5011. [func] Remove support for unthreaded named. [GL #478]
- 5010. [func] New "validate-except" option specifies a list of domains beneath which DNSSEC validation should not be performed. [GL #237]
- 5009. [bug] Upon an OpenSSL failure, the first error in the OpenSSL error queue was not logged. [GL #476]
- 5008. [bug] "rndc signing -nsec3param ..." requests were silently ignored for zones which were not yet loaded or transferred. [GL #468]
- 5007. [cleanup] Replace custom ISC boolean and integer data types with C99 stdint.h and stdbool.h types. [GL #9]
- 5006. [cleanup] Code preparing a delegation response was extracted from query\_delegation() and query\_zone\_delegation() into a separate function in order to decrease code duplication. [GL #431]
- 5005. [bug] dnssec-verify, and dnssec-signzone at the verification

(continues on next page)

(continued from previous page)

		step, failed on some validly signed zones. [GL #442]
5004.	[bug]	'rndc reconfig' could cause inline zones to stop re-signing. [GL #439]
5003.	[bug]	dns_acl_isinsecure did not handle geoip elements. [GL #406]
5002.	[bug]	mdig: Handle malformed +ednsopt option, support 100 +ednsopt options per query rather than 100 total and address memory leaks if +ednsopt was specified. [GL #410]
5001.	[bug]	Fix refcount errors on error paths. [GL #563]
5000.	[bug]	named_server_servestale() could leave the server in exclusive mode if an error occurred. [GL #441]
4999.	[cleanup]	Remove custom printf implementation in lib/isc/print.c. [GL #261]
4998.	[test]	Make resolver and cachedclean tests more civilized.
4997.	[security]	named could crash during recursive processing of DNAME records when "deny-answer-aliases" was in use. (CVE-2018-5740) [GL #387]
4996.	[bug]	dig: Handle malformed +ednsopt option. [GL #403]
4995.	[test]	Add tests for "tcp-self" update policy. [GL #282]
4994.	[bug]	Trust anchor telemetry queries were not being sent upstream for locally served zones. [GL #392]
4993.	[cleanup]	Remove support for silently ignoring 'no-change' deltas from BIND 8 when processing an IXFR stream. 'no-change' deltas will now trigger a fallback to AXFR as the recovery mechanism. [GL #369]
4992.	[bug]	The wrong address was being logged for trust anchor telemetry queries. [GL #379]
4991.	[bug]	"rndc reconfig" was incorrectly handling zones whose "mirror" setting was changed. [GL #381]
4990.	[bug]	Prevent a possible NULL reference in pkcs11-keygen. [GL #401]
4989.	[cleanup]	IDN support in dig has been reworked. IDNA2003 fallbacks were removed in the process. [GL #384]
4988.	[bug]	Don't synthesize NXDOMAIN from NSEC for records under

(continues on next page)

(continued from previous page)

a DNAME.

--- 9.13.2 released ---

- 4987. [cleanup] dns\_rdataslab\_tordataset() and its related dns\_rdatasetmethods\_t callbacks were removed as they were not being used by anything in BIND. [GL #371]
- 4986. [func] When built on Linux, BIND now requires the libcap library to set process privileges, unless capability support is explicitly overridden with "configure --disable-linux-caps". [GL #321]
- 4985. [func] Add a new slave zone option, "mirror", to enable serving a non-authoritative copy of a zone that is subject to DNSSEC validation before being used. For now, this option is only meant to facilitate deployment of an RFC 7706-style local copy of the root zone. [GL #33]
- 4984. [bug] Improve handling of very large incremental zone transfers to prevent journal corruption. [GL #339]
- 4983. [func] Add the ability to not return a DNS COOKIE option when one is present in the request (answer-cookie no;). [GL #173]
- 4982. [cleanup] Return FORMERR if the question section is empty and no COOKIE option is present; this restores older behavior except in the newly specified COOKIE case. [GL #260]
- 4981. [bug] Fix race in cmsg buffer usage in socket code. [GL #180]
- 4980. [bug] Named-checkconf failed to detect bad in-view targets. [GL #288]
- 4979. [placeholder]
- 4978. [test] Fix error handling and resolver configuration in the "rpz" system test. [GL #312]
- 4977. [func] When starting up, log the same details that would be reported by 'named -V'. [GL #247]
- 4976. [bug] Log the label with invalid prefix length correctly when loading RPZ zones. [GL #254]
- 4975. [bug] The server cookie computation for sha1 and sha256 did not match the method described in RFC 7873. [GL #356]

(continues on next page)

(continued from previous page)

4974.	[bug]	Restore default rrset-order to random. [GL #336]
4973.	[func]	verifyzone() and the functions it uses were moved to libdns and refactored to prevent exit() from being called upon failure. A side effect of that is that dnssec-signzone and dnssec-verify now check for memory leaks upon shutdown. [GL #266]
4972.	[func]	Declare the 'rdata' argument for dns_rdata_tostruct() to be const. [GL #341]
4971.	[bug]	dnssec-signzone and dnssec-verify did not treat records below a DNAME as out-of-zone data. [GL #298]
4970.	[func]	Add QNAME minimization option to resolver. [GL #16]
4969.	[cleanup]	Refactor zone logging functions. [GL #269]

--- 9.13.1 released ---		
4968.	[bug]	If glue records are signed, attempt to validate them. [GL #209]
4967.	[cleanup]	Add "answer-cookie" to the parser, marked obsolete.
4966.	[placeholder]	
4965.	[func]	Add support for marking options as deprecated. [GL #322]
4964.	[bug]	Reduce the probability of double signature when deleting a DNSKEY by checking if the node is otherwise signed by the algorithm of the key to be deleted. [GL #240]
4963.	[test]	ifconfig.sh now uses "ip" instead of "ifconfig", if available, to configure the test interfaces on linux. [GL #302]
4962.	[cleanup]	Move 'named -T' processing to its own function. [GL #316]
4961.	[protocol]	Remove support for ECC-GOST (GOST R 34.11-94). [GL #295]
4960.	[security]	When recursion is enabled, but the "allow-recursion" and "allow-query-cache" ACLs are not specified, they should be limited to local networks, but were inadvertently set to match the default "allow-query", thus allowing remote queries. (CVE-2018-5738) [GL #309]
4959.	[func]	NSID logging (enabled by the "request-nsid" option)

(continues on next page)

(continued from previous page)

		now has its own "nsid" category, instead of using the "resolver" category. [GL !332]
4958.	[bug]	Remove redundant space from NSEC3 record. [GL #281]
4957.	[func]	The default setting for "dnssec-validation" is now "auto", which activates DNSSEC validation using the IANA root key. (The default can be changed back to "yes", which activates DNSSEC validation only when keys are explicitly configured in named.conf, by building BIND with "configure --disable-auto-validation".) [GL #30]
4956.	[func]	Change isc_random() to be just PRNG using xoshiro128**, and add isc_nonce_buf() that uses CSPRNG. [GL #289]
4955.	[cleanup]	Silence cppcheck warnings in lib/dns/master.c. [GL #286]
4954.	[func]	Messages about serving of stale answers are now directed to the "serve-stale" logging category. Also clarified serve-stale documentation. [GL !323]
4953.	[bug]	Removed the option to build the red black tree database without a hash table; the non-hashing version was buggy and is not needed. [GL #184]
4952.	[func]	Authoritative server support in named for the EDNS CLIENT-SUBNET option (which was experimental and not practical to deploy) has been removed.  The ECS option is still supported in dig and mdig via the +subnet option, and can be parsed and logged when received by named, but it is no longer used for ACL processing. The "geoip-use-ecs" option is now obsolete; a warning will be logged if it is used in named.conf. "ecs" tags in an ACL definition are also obsolete and will cause the configuration to fail to load. [GL #32]
4951.	[protocol]	Add "HOME.ARPA" to list of built in empty zones as per RFC 8375. [GL #273]

		--- 9.13.0 released ---
4950.	[bug]	ISC_SOCKEVENTATTR_TRUNC was not be set. [GL #238]
4949.	[placeholder]	
4948.	[bug]	When request-nsid is turned on, EDNS NSID options should be logged at level info. Since change 3741 they have been logged at debug(3) by mistake.

(continues on next page)

(continued from previous page)

		[GL !290]
4947.	[func]	Replace all random functions with <code>isc_random()</code> , <code>isc_random_buf()</code> and <code>isc_random_uniform()</code> API. [GL #221]
4946.	[bug]	Additional glue was not being returned by resolver for unsigned zones since change 4596. [GL #209]
4945.	[func]	BIND can no longer be built without DNSSEC support. A cryptography provider (i.e., OpenSSL or a hardware service module with PKCS#11 support) must be available. [GL #244]
4944.	[cleanup]	Silence <code>cppcheck</code> portability warnings in <code>lib/isc/tests/buffer_test.c</code> . [GL #239]
4943.	[bug]	Change 4687 consumed too much memory when running system tests with <code>--with-tuning=large</code> . Reduced the hash table size to 512 entries for 'named -m record' restoring the previous memory footprint. [GL #248]
4942.	[cleanup]	Consolidate multiple instances of splitting of batchline in <code>dig</code> into a single function. [GL #196]
4941.	[cleanup]	Silence <code>clang</code> static analyzer warnings. [GL #196]
4940.	[cleanup]	Extract the loop in <code>dns__zone_updatesigs()</code> into separate functions to improve code readability. [GL #135]
4939.	[test]	Add basic unit tests for <code>update_sigs()</code> . [GL #135]
4938.	[placeholder]	
4937.	[func]	Remove support for OpenSSL < 1.0.0 [GL #191]
4936.	[func]	Always use OpenSSL or PKCS#11 random data providers, and remove the <code>--{enable,disable}-crypto-rand</code> configure options. [GL #165]
4935.	[func]	Add support for LibreSSL >= 2.7.0 (some OpenSSL 1.1.0 call were added). [GL #191]
4934.	[security]	The <code>serve-stale</code> feature could cause an assertion failure in <code>rbtdb.c</code> even when <code>stale-answer-enable</code> was false. Simultaneous use of stale cache records and NSEC aggressive negative caching could trigger a recursion loop. (CVE-2018-5737) [GL #185]
4933.	[bug]	Not creating signing keys for an inline signed zone prevented changes applied to the raw zone from being

(continues on next page)

(continued from previous page)

		reflected in the secure zone until signing keys were made available. [GL #159]
4932.	[bug]	Bumped signed serial of an inline signed zone was logged even when an error occurred while updating signatures. [GL #159]
4931.	[func]	Removed the "rbtdb64" database implementation. [GL #217]
4930.	[bug]	Remove a bogus check in nslookup command line argument processing. [GL #206]
4929.	[func]	Add the ability to set RA and TC in queries made by dig (+[no]raflag, +[no]tcflag). [GL #213]
4928.	[func]	The "dnskey-sig-validity" option allows "sig-validity-interval" to be overridden for signatures covering DNSKEY RRsets. [GL #145]
4927.	[placeholder]	
4926.	[func]	Add root key sentinel support. To disable, add 'root-key-sentinel no;' to named.conf. [GL #37]
4925.	[func]	Several configuration options that define intervals can now take TTL value suffixes (for example, 2h or 1d) in addition to integer parameters. These include max-cache-ttl, max-ncache-ttl, max-policy-ttl, fstrm-set-reopen-interval, interface-interval, and min-update-interval. [GL #203]
4924.	[cleanup]	Clean up the isc_string_* namespace and leave only strlcpy and strlcat. [GL #178]
4923.	[cleanup]	Refactor socket and socket event options into enum types. [GL #135]
4922.	[bug]	dnstap: Log the destination address of client packets rather than the interface address. [GL #197]
4921.	[cleanup]	Add dns_fixedname_initname() and refactor the caller code to make usage of the new function, as a part of refactoring dns_fixedname_*() macros were turned into functions. [GL #183]
4920.	[cleanup]	Clean up libdns removing most of the backwards compatibility wrappers.
4919.	[cleanup]	Clean up the isc_hash_* namespace and leave only the FNV-1a hash implementation. [GL #178]

(continues on next page)

(continued from previous page)

- 4918. [bug] Fix double free after keygen error in dnssec-keygen when OpenSSL >= 1.1.0 is used and RSA\_generate\_key\_ex fails. [GL #109]
- 4917. [func] Support 64 RPZ policy zones by default. [GL #123]
- 4916. [func] Remove IDNA2003 support and the bundled idnkit-1.0 library.
- 4915. [func] Implement IDNA2008 support in dig by adding support for libidn2. New dig option +idnin has been added, which allows to process invalid domain names much like dig without IDN support. libidn2 version 2.0 or higher is needed for +idnout enabled by default.
- 4914. [security] A bug in zone database reference counting could lead to a crash when multiple versions of a slave zone were transferred from a master in close succession. (CVE-2018-5736) [GL #134]
- 4913. [test] Re-implemented older unit tests in bin/tests as ATF, removed the lib/tests unit testing library. [GL #115]
- 4912. [test] Improved the reliability of the 'cds' system test. [GL #136]
- 4911. [test] Improved the reliability of the 'mkeys' system test. [GL #128]
- 4910. [func] Update util/check-changes to work on release branches. [GL #113]
- 4909. [bug] named-checkconf did not detect in-view zone collisions. [GL #125]
- 4908. [test] Eliminated unnecessary waiting in the allow\_query system test. Also changed its name to allow-query. [GL #81]
- 4907. [test] Improved the reliability of the 'notify' system test. [GL #59]
- 4906. [func] Replace getquad() with inet\_pton(), completing change #4900. [GL #56]
- 4905. [bug] irs\_resconf\_load() ignored resolv.conf syntax errors when "domain" or "search" options were present in that file. [GL #110]
- 4904. [bug] Temporarily revert change #4859. [GL #124]

(continues on next page)

(continued from previous page)

- 4903. [bug] "check-mx fail;" did not prevent MX records containing IP addresses from being added to a zone by a dynamic update. [GL #112]
- 4902. [test] Improved the reliability of the 'ixfr' system test. [GL #66]
- 4901. [func] "dig +nssearch" now lists the name servers for a domain that time out, as well as the servers that respond. [GL #64]
- 4900. [func] Remove all uses of inet\_aton(). As a result of this change, IPv4 addresses are now only accepted in dotted-quad format. [GL #13]
- 4899. [test] Convert most of the remaining system tests to be able to run in parallel, continuing the work from change #4895. To take advantage of this, use "make -jN check", where N is the number of processors to use. [GL #91]
- 4898. [func] Remove libseccomp based system-call filtering. [GL #93]
- 4897. [test] Update to rpz system test so that it doesn't recurse. [GL #68]
- 4896. [test] cacheclean system test was not robust. [GL #82]
- 4895. [test] Allow some system tests to run in parallel. [RT #46602]
- 4894. [bug] named could crash while rolling a dnstap output file. [RT #46942]
- 4893. [bug] Address various issues reported by cppcheck. [GL #51]
- 4892. [bug] named could leak memory when "rndc reload" was invoked before all zone loading actions triggered by a previous "rndc reload" command were completed. [RT #47076]
- 4891. [placeholder]
- 4890. [func] Remove unused ondestroy callback from libisc. [isc-projects/bind9!3]
- 4889. [func] Warn about the use of old root keys without the new root key being present. Warn about dlvs.isc.org's key being present. Warn about both managed and trusted root keys being present. [RT #43670]
- 4888. [test] Initialize sockets correctly in sample-update so that the nsupdate system test will run on Windows. [RT #47097]

(continues on next page)

(continued from previous page)

- 4887. [test] Enable the rpzrecurse test to run on Windows.  
[RT #47093]
- 4886. [doc] Document dig -u in manpage. [RT #47150]
- 4885. [security] update-policy rules that otherwise ignore the name field now require that it be set to "." to ensure that any type list present is properly interpreted.  
[RT #47126]
- 4884. [bug] named could crash on shutdown due to a race between shutdown\_server() and ns\_\_client\_request(). [RT #47120]
- 4883. [cleanup] Improved debugging output from dnssec-cds. [RT #47026]
- 4882. [bug] Address potential memory leak in dns\_update\_signaturesinc. [RT #47084]
- 4881. [bug] Only include dst\_openssl.h when OpenSSL is required.  
[RT #47068]
- 4880. [bug] Named wasn't returning the target of a cross-zone CNAME between two served zones when recursion was desired and available (RD=1, RA=1). (When this is not the case, the CNAME target is deliberately withheld to prevent accidental cache poisoning.)  
[RT #47078]
- 4879. [bug] dns\_rdata\_caa:value\_len field was too small.  
[RT #47086]
- 4878. [bug] List 'ply' as a requirement for the 'isc' python package. [RT #47065]
- 4877. [bug] Address integer overflow when exponentially backing off retry intervals. [RT #47041]
- 4876. [bug] Address deadlock with accessing a keytable. [RT #47000]
- 4875. [bug] Address compile failures on older systems. [RT #47015]
- 4874. [bug] Wrong time display when reporting new keywarntime.  
[RT #47042]
- 4873. [doc] Grammars for named.conf included in the ARM are now automatically generated by the configuration parser itself. As a side effect of the work needed to separate zone type grammars from each other, this also makes checking of zone statements in named-checkconf more correct and consistent.  
[RT #36957]

(continues on next page)

(continued from previous page)

- 4872. [bug] Don't permit loading meta RR types such as TKEY from master files. [RT #47009]
- 4871. [bug] Fix configure glitch in detecting stdatomic.h support on systems with multiple compilers. [RT #46959]
- 4870. [test] Update included ATF library to atf-0.21 preserving the ATF tool. [RT #46967]
- 4869. [bug] Address some cases where NULL with zero length could be passed to memmove which is undefined behavior and can lead to bad optimization. [RT #46888]
- 4868. [func] dnssec-keygen can no longer generate HMAC keys. Use tsig-keygen instead. [RT #46404]
- 4867. [cleanup] Normalize rndc on/off commands (validation, querylog, serve-stale) so they all accept the same synonyms for on/off (yes/no, true/false, enable/disable). Thanks to Tony Finch. [RT #47022]
- 4866. [port] DST library initialization verifies MD5 (when MD5 was not disabled) and SHA-1 hash and HMAC support. [RT #46764]
- 4865. [cleanup] Simplify handling isc\_socket\_sendto2() return values. [RT #46986]
- 4864. [bug] named acting as a slave for a catalog zone crashed if the latter contained a master definition without an IP address. [RT #45999]
- 4863. [bug] Fix various other bugs reported by Valgrind's memcheck tool. [RT #46978]
- 4862. [bug] The rdata flags for RRSIG were not being properly set when constructing a rdataslab. [RT #46978]
- 4861. [bug] The isc\_crc64 unit test was not endian independent. [RT #46973]
- 4860. [bug] isc\_int8\_t should be signed char. [RT #46973]
- 4859. [bug] A loop was possible when attempting to validate unsigned CNAME responses from secure zones; this caused a delay in returning SERVFAIL and also increased the chances of encountering CVE-2017-3145. [RT #46839]
- 4858. [security] Addresses could be referenced after being freed

(continues on next page)

(continued from previous page)

- in resolver.c, causing an assertion failure.  
(CVE-2017-3145) [RT #46839]
- 4857. [bug] Maintain attach/detach semantics for event->db, event->node, event->rdataset and event->sigrdataset in query.c. [RT #46891]
- 4856. [bug] 'rndc zonestatus' reported the wrong underlying type for a inline slave zone. [RT #46875]
- 4855. [bug] isc\_time\_formatshorttimestamp produced incorrect output. [RT #46938]
- 4854. [bug] query\_synthcnamewildcard should stop generating the response if query\_synthwildcard fails. [RT #46939]
- 4853. [bug] Add REQUIRE's and INSIST's to isc\_time\_formatISO8601L and isc\_time\_formatISO8601Lms. [RT #46916]
- 4852. [bug] Handle strftime() failing in isc\_time\_formatISO8601ms. Add REQUIRE's and INSIST's to isc\_time\_formattimestamp, isc\_time\_formathttptimestamp, isc\_time\_formatISO8601, isc\_time\_formatISO8601ms. [RT #46892]
- 4851. [port] Support using kyua as well as atf-run to run the unit tests. [RT #46853]
- 4850. [bug] Named failed to restart with multiple added zones in lmdb database. [RT #46889]
- 4849. [bug] Duplicate zones could appear in the .nzf file if addzone failed. [RT #46435]
- 4848. [func] Zone types "primary" and "secondary" can now be used as synonyms for "master" and "slave" in named.conf. [RT #46713]
- 4847. [bug] dnssec-dnskey-kskonly was not being honored for CDS and CDNSKEY. [RT #46755]
- 4846. [test] Adjust timing values in runtime system test. Address named.pid removal races in runtime system test. [RT #46800]
- 4845. [bug] Dig (non iOS) should exit on malformed names. [RT #46806]
- 4844. [test] Address memory leaks in libatf-c. [RT #46798]
- 4843. [bug] dnssec-signzone free hashlist on exit. [RT #46791]
- 4842. [bug] Conditionally compile opensslecdsa\_link.c to avoid

(continues on next page)

(continued from previous page)

warnings about unused function. [RT #46790]

--- 9.12.0rc1 released ---

- 4841. [bug] Address -fsanitize=undefined warnings. [RT #46786]
- 4840. [test] Add tests to cover fallback to using ZSK on inactive KSK. [RT #46787]
- 4839. [bug] zone.c:zone\_sign was not properly determining if there were active KSK and ZSK keys for a algorithm when update-check-ksk is true (default) leaving records unsigned with one or more DNSKEY algorithms. [RT #46774]
- 4838. [bug] zone.c:add\_sigs was not properly determining if there were active KSK and ZSK keys for a algorithm when update-check-ksk is true (default) leaving records unsigned with one or more DNSKEY algorithms. [RT #46754]
- 4837. [bug] dns\_update\_signatures{inc} (add\_sigs) was not properly determining if there were active KSK and ZSK keys for a algorithm when update-check-ksk is true (default) leaving records unsigned when there were multiple DNSKEY algorithms for the zone. [RT #46743]
- 4836. [bug] Zones created using "rndc addzone" could temporarily fail to inherit an "allow-transfer" ACL that had been configured in the options statement. [RT #46603]
- 4835. [cleanup] Clean up and refactor LMDB-related code. [RT #46718]
- 4834. [port] Fix LMDB support on OpenBSD. [RT #46718]
- 4833. [bug] isc\_event\_free should check that the event is not linked when called. [RT #46725]
- 4832. [bug] Events were not being removed from zone->rss\_events. [RT #46725]
- 4831. [bug] Convert the RRSIG expirytime to 64 bits for comparisons in diff.c:resign. [RT #46710]
- 4830. [bug] Failure to configure ATF when requested did not cause an error in top-level configure script. [RT #46655]
- 4829. [bug] isc\_heap\_delete did not zero the index value when the heap was created with a callback to do that. [RT #46709]

(continues on next page)

(continued from previous page)

- 4828. [bug] Do not use thread-local storage for storing LMDB reader locktable slots. [RT #46556]
- 4827. [misc] Add a precommit check script util/checklibs.sh [RT #46215]
- 4826. [cleanup] Prevent potential build failures in bin/confgen/ and bin/named/ when using parallel make. [RT #46648]
- 4825. [bug] Prevent a bogus "error during managed-keys processing (no more)" warning from being logged. [RT #46645]
- 4824. [port] Add iOS hooks to dig. [RT #42011]
- 4823. [test] Refactor reclimit system test to improve its reliability and speed. [RT #46632]
- 4822. [bug] Use resign\_sooner in dns\_db\_setsigningtime. [RT #46473]
- 4821. [bug] When resigning ensure that the SOA's expire time is always later that the resigning time of other records. [RT #46473]
- 4820. [bug] dns\_db\_subtractdataset should transfer the resigning information to the new header. [RT #46473]
- 4819. [bug] Fully backout the transaction when adding a RRset to the resigning / removal heaps fails. [RT #46473]
- 4818. [test] The logfileconfig system test could intermittently report false negatives on some platforms. [RT #46615]
- 4817. [cleanup] Use DNS\_NAME\_INITABSOLUTE and DNS\_NAME\_INITNONABSOLUTE. [RT #45433]
- 4816. [bug] Don't use a common array for storing EDNS options in DiG as it could fill up. [RT #45611]
- 4815. [bug] rbt\_test.c:insert\_and\_delete needed to call dns\_rbt\_addnode instead of dns\_rbt\_addname. [RT #46553]
- 4814. [cleanup] Use AS\_HELP\_STRING for consistent help text. [RT #46521]
- 4813. [bug] Address potential read after free errors from query\_synthnodata, query\_synthwildcard and query\_synthnxdomain. [RT #46547]
- 4812. [bug] Minor improvements to stability and consistency of code handling managed keys. [RT #46468]
- 4811. [bug] Revert api changes to use <isc/buffer.h> inline

(continues on next page)

(continued from previous page)

```

macros. Provide a alternative mechanism to turn
on the use of inline macros when building BIND.
[RT #46520]

4810. [test] The chain system test failed if the IPv6 interfaces
were not configured. [RT #46508]

```

```

--- 9.12.0b2 released ---

4809. [port] Check at configure time whether -latomic is needed
for stdatomic.h. [RT #46324]

4808. [bug] Properly test for zlib.h. [RT #46504]

4807. [cleanup] isc_rng_randombytes() returns a specified number of
bytes from the PRNG; this is now used instead of
calling isc_rng_random() multiple times. [RT #46230]

4806. [func] Log messages related to loading of zones are now
directed to the "zoneload" logging category.
[RT #41640]

4805. [bug] TCP4Active and TCP6Active weren't being updated
correctly. [RT #46454]

4804. [port] win32: access() does not work on directories as
required by POSIX. Supply a alternative in
isc_file_isdirwritable. [RT #46394]

4803. [placeholder]

4802. [test] Refactor mkeys system test to make it quicker and more
reliable. [RT #45293]

4801. [func] 'dnssec-lookaside auto;' and 'dnssec-lookaside .
trust-anchor dlv.isc.org;' now elicit warnings rather
than being fatal configuration errors. [RT #46410]

4800. [bug] When processing delzone, write one zone config per
line to the NZF. [RT #46323]

4799. [cleanup] Improve clarity of keytable unit tests. [RT #46407]

4798. [func] Keys specified in "managed-keys" statements
are tagged as "initializing" until they have been
updated by a key refresh query. If initialization
fails it will be visible from "rndc secrets".
[RT #46267]

4797. [func] Removed "isc-hmac-fixup", as the versions of BIND that
had the bug it worked around are long past end of
life. [RT #46411]

```

(continues on next page)

(continued from previous page)

- 4796. [bug] Increase the maximum configurable TCP keepalive timeout to 65535. [RT #44710]
- 4795. [func] A new statistics counter has been added to track priming queries. [RT #46313]
- 4794. [func] "dnssec-checkkds -s" specifies a file from which to read a DS set rather than querying the parent. [RT #44667]
- 4793. [bug] nsupdate -[46] could overflow the array of server addresses. [RT #46402]
- 4792. [bug] Fix map file header correctness check. [RT #38418]
- 4791. [doc] Fixed outdated documentation about export libraries. [RT #46341]
- 4790. [bug] nsupdate could trigger a require when sending a update to the second address of the server. [RT #45731]
- 4789. [cleanup] Check writability of new-zones-directory. [RT #46308]
- 4788. [cleanup] When using "update-policy local", log a warning when an update matching the session key is received from a remote host. [RT #46213]
- 4787. [cleanup] Turn nsec3param\_salt\_totext() into a public function, dns\_nsec3param\_salttotext(), and add unit tests for it. [RT #46289]
- 4786. [func] The "filter-aaaa-on-v4" and "filter-aaaa-on-v6" options are no longer conditionally compiled. [RT #46340]
- 4785. [func] The hmac-md5 algorithm is no longer recommended for use with RNDK keys. The default in rndc-confgen is now hmac-sha256. [RT #42272]
- 4784. [func] The use of dnssec-keygen to generate HMAC keys is deprecated in favor of tsig-keygen. dnssec-keygen will print a warning when used for this purpose. All HMAC algorithms will be removed from dnssec-keygen in a future release. [RT #42272]
- 4783. [test] dnssec: 'check that NOTIFY is sent at the end of NSEC3 chain generation failed' required more time on some machines for the IXFR to complete. [RT #46388]
- 4782. [test] dnssec: 'checking positive and negative validation

(continues on next page)

(continued from previous page)

		with negative trust anchors' required more time to complete on some machines. [RT #46386]
4781.	[maint]	B.ROOT-SERVERS.NET is now 199.9.14.201. [RT #45889]
4780.	[bug]	When answering ANY queries, don't include the NS RRset in the authority section if it was already in the answer section. [RT #44543]
4779.	[bug]	Expire NTA at the start of the second. Don't update the expiry value if the record has already expired after a successful check. [RT #46368]
4778.	[test]	Improve synth-from-dnssec testing. [RT #46352]
4777.	[cleanup]	Removed a redundant call to configure_view_acl(). [RT #46369]
4776.	[bug]	Improve portability of ht_test. [RT #46333]
4775.	[bug]	Address Coverity warnings in ht_test.c and mem_test.c [RT #46281]
4774.	[bug]	<isc/util.h> was incorrectly included in several header files. [RT #46311]
4773.	[doc]	Fixed generating Doxygen documentation for functions annotated using certain macros. Miscellaneous Doxygen-related cleanups. [RT #46276]

		--- 9.12.0b1 released ---
4772.	[test]	Expanded unit testing framework for libns, using hooks to interrupt query flow and inspect state at specified locations. [RT #46173]
4771.	[bug]	When sending RFC 5011 refresh queries, disregard cached DNSKEY rrsets. [RT #46251]
4770.	[bug]	Cache additional data from priming queries as glue. Previously they were ignored as unsigned non-answer data from a secure zone, and never actually got added to the cache, causing hints to be used frequently for root-server addresses, which triggered re-priming. [RT #45241]
4769.	[func]	The working directory and managed-keys directory has to be writeable (and seekable). [RT #46077]
4768.	[func]	By default, memory is no longer filled with tag values when it is allocated or freed; this improves performance but makes debugging of certain memory

(continues on next page)

(continued from previous page)

		issues more difficult. "named -M fill" turns memory filling back on. (Building "configure --enable-developer", turns memory fill on by default again; it can then be disabled with "named -M nofill".) [RT #45123]
4767.	[func]	Add a new function, <code>isc_buffer_printf()</code> , which can be used to append a formatted string to the used region of a buffer. [RT #46201]
4766.	[cleanup]	Address Coverity warnings. [RT #46150]
4765.	[bug]	Address potential INSIST in <code>dnssec-cds</code> . [RT #46150]
4764.	[bug]	Address portability issues in <code>cds</code> system test. [RT #46214]
4763.	[contrib]	Improve compatibility when building MySQL DLZ module by using <code>mysql_config</code> if available. [RT #45558]
4762.	[func]	"update-policy local" is now restricted to updates from local addresses. (Previously, other addresses were allowed so long as updates were signed by the local session key.) [RT #45492]
4761.	[protocol]	Add support for DOA. [RT #45612]
4760.	[func]	Add glue cache statistics counters. [RT #46028]
4759.	[func]	Add logging channel "trust-anchor-telemetry" to record trust-anchor-telemetry in incoming requests. Both <code>_ta-XXXX.&lt;anchor&gt;/NULL</code> and EDNS KEY-TAG options are logged. [RT #46124]
4758.	[doc]	Remove documentation of unimplemented "topology". [RT #46161]
4757.	[func]	New "dnssec-cds" command creates a new parent DS RRset based on CDS or CDNSKEY RRsets found in a child zone, and generates either a <code>dsset</code> file or stream of <code>nsupdate</code> commands to update the parent. Thanks to Tony Finch. [RT #46090]
4756.	[bug]	Interrupting <code>dig</code> could lead to an INSIST failure after certain errors were encountered while querying a host whose name resolved to more than one address. Change 4537 increased the odds of triggering this issue by causing <code>dig</code> to hang indefinitely when certain error paths were evaluated. <code>dig</code> now also retries TCP queries (once) if the server gracefully closes the connection before sending a response. [RT #42832, #45159]

(continues on next page)

(continued from previous page)

- 4755. [cleanup] Silence unnecessary log message when NZF file doesn't exist. [RT #46186]
- 4754. [bug] dns\_zone\_setview needs a two stage commit to properly handle errors. [RT #45841]
- 4753. [contrib] Software obtainable from known upstream locations (i.e., zkt, nslint, query-loc) has been removed. Links to these and other packages can be found at <https://www.isc.org/community/tools> [RT #46182]
- 4752. [test] Add unit test for isc\_net\_pton. [RT #46171]
- 4751. [func] "dnssec-signzone -S" can now automatically add parent synchronization records (CDS and CDNSKEY) according to key metadata set using the -Psync and -Dsync options to dnssec-keygen and dnssec-settime. [RT #46149]
- 4750. [func] "rndc managed-keys destroy" shuts down RFC 5011 key maintenance and deletes the managed-keys database. If followed by "rndc reconfig" or a server restart, key maintenance is reinitialized from scratch. This is primarily intended for testing. [RT #32456]
- 4749. [func] The ISC DLV service has been shut down, and all DLV records have been removed from dlvs.isc.org.
  - Removed references to ISC DLV in documentation
  - Removed DLV key from bind.keys
  - No longer use ISC DLV by default in delv
  - "dnssec-lookaside auto" and configuration of "dnssec-lookaide" with dlvs.isc.org as the trust anchor are both now fatal errors.
 [RT #46155]
- 4748. [cleanup] Sprintf to snprintf conversions. [RT #46132]
- 4747. [func] Synthesis of responses from DNSSEC-verified records. Stage 3 - synthesize NODATA responses. [RT #40138]
- 4746. [cleanup] Add configured prefixes to configure summary output. [RT #46153]
- 4745. [test] Add color-coded pass/fail messages to system tests when running on terminals that support them. [RT #45977]
- 4744. [bug] Suppress trust-anchor-telemetry queries if validation is disabled. [RT #46131]
- 4743. [func] Exclude trust-anchor-telemetry queries from

(continues on next page)

(continued from previous page)

		synth-from-dnssec processing. [RT #46123]
4742.	[func]	Synthesis of responses from DNSSEC-verified records. Stage 2 - synthesis of records from wildcard data. If the dns64 or filter-aaaa* is configured then the involved lookups are currently excluded. [RT #40138]
4741.	[bug]	Make isc_refcount_current() atomically read the counter value. [RT #46074]
4740.	[cleanup]	Avoid triggering format-truncated warnings. [RT #46107]
4739.	[cleanup]	Address clang static analysis warnings. [RT #45952]
4738.	[port]	win32: strftime mishandles %Z. [RT #46039]
4737.	[cleanup]	Address Coverity warnings. [RT #46012]
4736.	[cleanup]	(a) Added comments to NSEC3-related functions in lib/dns/zone.c. (b) Refactored NSEC3 salt formatting code. (c) Minor tweaks to lock and result handling. [RT #46053]
4735.	[bug]	Add @ISC_OPENSSL_LIBS@ to isc-config. [RT #46078]
4734.	[contrib]	Added sample configuration for DNS-over-TLS in contrib/dnspriv.
4733.	[bug]	Change #4706 introduced a bug causing TCP clients not be reused correctly, leading to unconstrained memory growth. [RT #46029]
4732.	[func]	Change default minimal-responses setting to no-auth-recursive. [RT #46016]
4731.	[bug]	Fix use after free when closing an LMDB. [RT #46000]
4730.	[bug]	Fix out of bounds access in DHCID totext() method. [RT #46001]
4729.	[bug]	Don't use memset() to wipe memory, as it may be removed by compiler optimizations when the memset() occurs on automatic stack allocation just before function return. [RT #45947]
4728.	[func]	Use C11's stdatomic.h instead of isc_atomic where available. [RT #40668]
4727.	[bug]	Retransferring an inline-signed slave using NSEC3 around the time its NSEC3 salt was changed could result in an infinite signing loop. [RT #45080]

(continues on next page)

(continued from previous page)

4726. [port] Prevent setsockopt() errors related to TCP\_FASTOPEN from being logged on FreeBSD if the kernel does not support it. Notify the user when the kernel does support TCP\_FASTOPEN, but it is disabled by sysctl. Add a new configure option, --disable-tcp-fastopen, to disable use of TCP\_FASTOPEN altogether. [RT #44754]
4725. [bug] Nsupdate: "recvsoa" was incorrectly reported for failures in sending the update message. The correct location to be reported is "update\_completed". [RT #46014]
4724. [func] By default, BIND now uses the random number functions provided by the crypto library (i.e., OpenSSL or a PKCS#11 provider) as a source of randomness rather than /dev/random. This is suitable for virtual machine environments which have limited entropy pools and lack hardware random number generators.
- This can be overridden by specifying another entropy source via the "random-device" option in named.conf, or via the -r command line option; however, for functions requiring full cryptographic strength, such as DNSSEC key generation, this cannot be overridden. In particular, the -r command line option no longer has any effect on dnssec-keygen.
- This can be disabled by building with "configure --disable-crypto-rand". [RT #31459] [RT #46047]
4723. [bug] Statistics counter DNSTAPdropped was misidentified as DNSSECdropped. [RT #46002]
4722. [cleanup] Clean up uses of strcpy() and strcat() in favor of strncpy() and strlcat() for safety. [RT #45981]
4721. [func] 'dnssec-signzone -x' and 'dnssec-dnskey-kskonly' options now apply to CDNSKEY and DS records as well as DNSKEY. Thanks to Tony Finch. [RT #45689]
4720. [func] Added a statistics counter to track prefetch queries. [RT #45847]
4719. [bug] Address PVS static analyzer warnings. [RT #45946]
4718. [func] Avoid searching for a owner name compression pointer more than once when writing out a RRset. [RT #45802]
4717. [bug] Treat replies with QCOUNT=0 as truncated if TC=1,

(continues on next page)

(continued from previous page)

```

FORMERR if TC=0, and log the error correctly.
[RT #45836]

4716. [placeholder]
    
```

```

--- 9.12.0a1 released ---

4715. [bug]      TreeMemMax was mis-identified as a second HeapMemMax
           in the Json cache statistics. [RT #45980]

4714. [port]    openbsd/libressl: add support for building with
           --enable-openssl-hash. [RT #45982]

4713. [func]    Added support for the DNS Response Policy Service
           (DNSRPS) API, which allows named to use an external
           response policy daemon when built with
           "configure --enable-dnsrps". Thanks to Farsight
           Security. [RT #43376]

4712. [bug]    "dig +domain" and "dig +search" didn't retain the
           search domain when retrying with TCP. [RT #45547]

4711. [test]    Some RR types were missing from genzones.sh.
           [RT #45782]

4710. [cleanup] Changed the --enable-openssl-hash default to yes.
           [RT #45019]

4709. [cleanup] Use dns_name_fullhash() to hash names for RRL.
           [RT #45435]

4708. [cleanup] Legacy Windows builds (i.e. for XP and earlier)
           are no longer supported. [RT #45186]

4707. [func]    The lightweight resolver daemon and library (lwresd
           and liblwres) have been removed. [RT #45186]

4706. [func]    Code implementing name server query processing has
           been moved from bin/named to a new library "libns".
           Functions remaining in bin/named are now prefixed
           with "named_" rather than "ns_". This will make it
           easier to write unit tests for name server code, or
           link name server functionality into new tools.
           [RT #45186]

4705. [placeholder]

4704. [cleanup] Silence Visual Studio compiler warnings. [RT #45898]

4703. [bug]    BINDInstall.exe was missing some buffer length checks.
           [RT #45898]
    
```

(continues on next page)

(continued from previous page)

- 4702. [func] Update function declarations to use `dns_masterstyle_flags_t` for style flags. [RT #45924]
- 4701. [cleanup] Refactored `lib/dns/tsig.c` to reduce code duplication and simplify the disabling of MD5. [RT #45490]
- 4700. [func] Serving of stale answers is now supported. This allows named to provide stale cached answers when the authoritative server is under attack. See `max-stale-ttl`, `stale-answer-enable`, `stale-answer-ttl`. [RT #44790]
- 4699. [func] Multiple `cookie-secret` clauses can now be specified. The first one specified is used to generate new server cookies. [RT #45672]
- 4698. [port] Add `--with-python-install-dir` configure option to allow specifying a nonstandard installation directory for Python modules. [RT #45407]
- 4697. [bug] Restore workaround for Microsoft Windows TSIG hash computation bug. [RT #45854]
- 4696. [port] Enable `filter-aaaa` support by default on Windows builds. [RT #45883]
- 4695. [bug] `cookie-secrets` were not being properly checked by `named-checkconf`. [RT #45886]
- 4694. [func] `dnssec-keygen` no longer uses RSASHA1 by default; the signing algorithm must be specified on the command line with the `"-a"` option. Signing scripts that rely on the existing default behavior will break; use `"dnssec-keygen -a RSASHA1"` to repair them. (The goal of this change is to make it easier to find scripts using RSASHA1 so they can be changed in the event of that algorithm being deprecated in the future.) [RT #44755]
- 4693. [func] Synthesis of responses from DNSSEC-verified records. Stage 1 covers NXDOMAIN synthesis from NSEC records. This is controlled by `synth-from-dnssec` and is enabled by default. [RT #40138]
- 4692. [bug] Fix build failures with `libressl` introduced in 4676. [RT #45879]
- 4691. [func] Add `-4/-6` command line options to `nsupdate` and `rndc`. [RT #45632]
- 4690. [bug] Command line options `-4/-6` were handled inconsistently

(continues on next page)

(continued from previous page)

		between tools. [RT #45632]
4689.	[cleanup]	Turn on minimal responses for CDNSKEY and CDS in addition to DNSKEY and DS. Thanks to Tony Finch. [RT #45690]
4688.	[protocol]	Check and display EDNS KEY TAG options (RFC 8145) in messages. [RT #44804]
4687.	[func]	Refactor tracklines code. [RT #45126]
4686.	[bug]	dnssec-settime -p could print a bogus warning about key deletion scheduled before its inactivation when a key had an inactivation date set but no deletion date set. [RT #45807]
4685.	[bug]	dnssec-settime incorrectly calculated publication and activation dates for a successor key. [RT #45806]
4684.	[bug]	delv could send bogus DNS queries when an explicit server address was specified on the command line along with -4/-6. [RT #45804]
4683.	[bug]	Prevent nsupdate from immediately exiting on invalid user input in interactive mode. [RT #28194]
4682.	[bug]	Don't report errors on records below a DNAME. [RT #44880]
4681.	[bug]	Log messages from the validator now include the associated view unless the view is "_default/IN" or "_dnsclient/IN". [RT #45770]
4680.	[bug]	Fix failing over to another master server address when nsupdate is used with GSS-API. [RT #45380]
4679.	[cleanup]	Suggest using -o when dnssec-verify finds a SOA record not at top of zone and -o is not used. [RT #45519]
4678.	[bug]	geoip-use-ecs has the wrong type when geoip support is disabled at configure time. [RT #45763]
4677.	[cleanup]	Split up the main function in dig to better support the iOS app version. [RT #45508]
4676.	[cleanup]	Allow BIND to be built using OpenSSL 1.0.X with deprecated functions removed. [RT #45706]
4675.	[cleanup]	Don't use C++ keyword class. [RT #45726]
4674.	[func]	"dig +sigchase", and related options "+topdown" and "+trusted-keys", have been removed. Use "delv" for

(continues on next page)

(continued from previous page)

		queries with DNSSEC validation. [RT #42793]
4673.	[port]	Silence GCC 7 warnings. [RT #45592]
4672.	[placeholder]	
4671.	[bug]	Fix a race condition that could cause the resolver to crash with assertion failure when chasing DS in specific conditions with a very short RTT to the upstream nameserver. [RT #45168]
4670.	[cleanup]	Ensure that a request MAC is never sent back in an XFR response unless the signature was verified. [RT #45494]
4669.	[func]	Iterative query logic in resolver.c has been refactored into smaller functions and commented, for improved readability, maintainability and testability. [RT #45362]
4668.	[bug]	Use localtime_r and gmtime_r for thread safety. [RT #45664]
4667.	[cleanup]	Refactor RDATA unit tests. [RT #45610]
4666.	[bug]	dnssec-keymgr: Domain names beginning with digits (0-9) could cause a parser error when reading the policy file. This now works correctly so long as the domain name is quoted. [RT #45641]
4665.	[protocol]	Added support for ED25519 and ED448 DNSSEC signing algorithms (RFC 8080). (Note: these algorithms depend on code currently in the development branch of OpenSSL which has not yet been released.) [RT #44696]
4664.	[func]	Add a "glue-cache" option to enable or disable the glue cache. The default is "yes". [RT #45125]
4663.	[cleanup]	Clarify error message printed by dnssec-dsfromkey. [RT #21731]
4662.	[performance]	Improve cache memory cleanup of zero TTL records by putting them at the tail of LRU header lists. [RT #45274]
4661.	[bug]	A race condition could occur if a zone was reloaded while resigning, triggering a crash in rbtodb.c:closeversion(). [RT #45276]
4660.	[bug]	Remove spurious "peer" from Windows socket log messages. [RT #45617]

(continues on next page)

(continued from previous page)

- 4659. [bug] Remove spurious log message about lmbd-mapsize not being supported when parsing builtin configuration file. [RT #45618]
- 4658. [bug] Clean up build directory created by "setup.py install" immediately. [RT #45628]
- 4657. [bug] rrchecker system test result could be improperly determined. [RT #45602]
- 4656. [bug] Apply "port" and "dscp" values specified in catalog zone's "default-masters" option to the generated configuration of its member zones. [RT #45545]
- 4655. [bug] Lack of seccomp could be falsely reported. [RT #45599]
- 4654. [cleanup] Don't use C++ keywords delete, new and namespace. [RT #45538]
- 4653. [bug] Reorder includes to move @DST\_OPENSSL\_INC@ and @ISC\_OPENSSL\_INC@ after shipped include directories. [RT #45581]
- 4652. [bug] Nsupdate could attempt to use a zeroed address on server timeout. [RT #45417]
- 4651. [test] Silence coverity warnings in tsig\_test.c. [RT #45528]
- 4650. [placeholder]
- 4649. [bug] The wrong zone was logged when a catalog zone is added. [RT #45520]
- 4648. [bug] "rndc reconfig" on a slave no longer causes all member zones of configured catalog zones to be removed from configuration. [RT #45310]
- 4647. [bug] Change 4643 broke verification of TSIG signed TCP message sequences where not all the messages contain TSIG records. These may be used in AXFR and IXFR responses. [RT #45509]
- 4646. [placeholder]
- 4645. [bug] Fix PKCS#11 RSA parsing when MD5 is disabled. [RT #45300]
- 4644. [placeholder]
- 4643. [security] An error in TSIG handling could permit unauthorized zone transfers or zone updates. (CVE-2017-3142)

(continues on next page)

(continued from previous page)

		(CVE-2017-3143) [RT #45383]
4642.	[cleanup]	Add more logging of RFC 5011 events affecting the status of managed keys: newly observed keys, deletion of revoked keys, etc. [RT #45354]
4641.	[cleanup]	Parallel builds (make -j) could fail with --with-atf / --enable-developer. [RT #45373]
4640.	[bug]	If query_findversion failed in query_getdb due to memory failure the error status was incorrectly discarded. [RT #45331]
4639.	[bug]	Fix a regression in --with-tuning reporting introduced by change 4488. [RT #45396]
4638.	[bug]	Reloading or reconfiguring named could fail on some platforms when LMDB was in use. [RT #45203]
4637.	[func]	"nsec3hash -r" option ("rdata order") takes arguments in the same order as they appear in NSEC3 or NSEC3PARAM records, so that NSEC3 parameters can be cut and pasted from an existing record. Thanks to Tony Finch for the contribution. [RT #45183]
4636.	[bug]	Normalize rpz policy zone names when checking for existence. [RT #45358]
4635.	[bug]	Fix RPZ NSDNAME logging that was logging failures as NSIP. [RT #45052]
4634.	[contrib]	check5011.pl needs to handle optional space before semi-colon in +multi-line output. [RT #45352]
4633.	[maint]	Updated AAAA (2001:500:200::b) for B.ROOT-SERVERS.NET.
4632.	[security]	The BIND installer on Windows used an unquoted service path, which can enable privilege escalation. (CVE-2017-3141) [RT #45229]
4631.	[security]	Some RPZ configurations could go into an infinite query loop when encountering responses with TTL=0. (CVE-2017-3140) [RT #45181]
4630.	[bug]	"dyndb" is dependent on dlopen existing / being enabled. [RT #45291]
4629.	[bug]	dns_client_startupupdate could not be called with a running client. [RT #45277]
4628.	[bug]	Fixed a potential reference leak in query_getdb(). [RT #45247]

(continues on next page)

(continued from previous page)

4627. [placeholder]
4626. [test] Added more tests for handling of different record ordering in CNAME and DNAME responses. [QA #430]
4625. [bug] Running "rndc addzone" and "rndc delzone" at close to the same time could trigger a deadlock if using LMDB. [RT #45209]
4624. [placeholder]
4623. [bug] Use --with-protobuf-c and --with-libfstrm to find protoc-c and fstrm\_capture. [RT #45187]
4622. [bug] Remove unnecessary escaping of semicolon in CAA and URI records. [RT #45216]
4621. [port] Force alignment of oid arrays to silence loader warnings. [RT #45131]
4620. [port] Handle EPFNOSUPPORT being returned when probing to see if a socket type is supported. [RT #45214]
4619. [bug] Call isc\_mem\_put instead of isc\_mem\_free in bin/named/server.c:setup\_newzones. [RT #45202]
4618. [bug] Check isc\_mem\_strdup results in dns\_view\_setnewzones. Add logging for lmbd call failures. [RT #45204]
4617. [test] Update rndc system test to be more delay tolerant. [RT #45177]
4616. [bug] When using LMDB, zones deleted using "rndc delzone" were not correctly removed from the new-zone database. [RT #45185]
4615. [bug] AD could be set on truncated answer with no records present in the answer and authority sections. [RT #45140]
4614. [test] Fixed an error in the sockaddr unit test. [RT #45146]
4613. [func] By default, the maximum size of a zone journal file is now twice the size of the zone's contents (there is little benefit to a journal larger than this). This can be overridden by setting "max-journal-size" to "unlimited" or to an explicit value up to 2G. Thanks to Tony Finch. [RT #38324]
4612. [bug] Silence 'may be use uninitialised' warning and simplify the code in lwres/getaddinfo:process\_answer.

(continues on next page)

(continued from previous page)

- [RT #45158]
4611. [bug] The default LMDB mapsize was too low and caused errors after few thousand zones were added using rndc addzone. A new config option "lmdb-mapsize" has been introduced to configure the LMDB mapsize depending on operational needs. [RT #44954]
4610. [func] The "new-zones-directory" option specifies the location of NZF or NZD files for storing configuration of zones added by "rndc addzone". Thanks to Petr Menšík. [RT #44853]
4609. [cleanup] Rearrange makefiles to enable parallel execution (i.e. "make -j"). [RT #45078]
4608. [func] DiG now warns about .local queries which are reserved for Multicast DNS. [RT #44783]
4607. [bug] The memory context's malloced and maxmalloced counters were being updated without the appropriate lock being held. [RT #44869]
4606. [port] Stop using experimental "Experimental keys on scalar" feature of perl as it has been removed. [RT #45012]
4605. [performance] Improve performance for delegation heavy answers and also general query performance. Removes the acache feature that didn't significantly improve performance. Adds a glue cache. Removes additional-from-cache and additional-from-auth features. Enables minimal-responses by default. Improves performance of compression code, owner case restoration, hash function, etc. Uses inline buffer implementation by default. Many other performance changes and fixes. [RT #44029]
4604. [bug] Don't use ERR\_load\_crypto\_strings() when building with OpenSSL 1.1.0. [RT #45117]
4603. [doc] Automatically generate named.conf(5) man page from doc/misc/options. Thanks to Tony Finch. [RT #43525]
4602. [func] Threads are now set to human-readable names to assist debugging, when supported by the OS. [RT #43234]
4601. [bug] Reject incorrect RSA key lengths during key generation and and sign/verify context

(continues on next page)

(continued from previous page)

		creation. [RT #45043]
4600.	[bug]	Adjust RPZ trigger counts only when the entry being deleted exists. [RT #43386]
4599.	[bug]	Fix inconsistencies in inline signing time comparison that were introduced with the introduction of rdatasetheader->resign_lsb. [RT #42112]
4598.	[func]	Update fuzzing code to (1) reply to a DNSKEY query from named with appropriate DNSKEY used in fuzzing; (2) patch the QTYPE correctly in resolver fuzzing; (3) comment things so the rest of us are able to understand how fuzzing is implemented in named; (4) Coding style changes, cleanup, etc. [RT #44787]
4597.	[bug]	The validator now ignores SHA-1 DS digest type when a DS record with SHA-384 digest type is present and is a supported digest type. [RT #45017]
4596.	[bug]	Validate glue before adding it to the additional section. This also fixes incorrect TTL capping when the RRSIG expired earlier than the TTL. [RT #45062]
4595.	[func]	dnssec-keygen will no longer generate RSA keys less than 1024 bits in length. dnssec-keymgr was similarly updated. [RT #36895]
4594.	[func]	"dnstap-read -x" prints a hex dump of the wire format of each logged DNS message. [RT #44816]
4593.	[doc]	Update README using markdown, remove outdated FAQ file in favor of the knowledge base.
4592.	[bug]	A race condition on shutdown could trigger an assertion failure in dispatch.c. [RT #43822]
4591.	[port]	Addressed some python 3 compatibility issues. Thanks to Ville Skytta. [RT #44955] [RT #44956]
4590.	[bug]	Support for PTHREAD_MUTEX_ADAPTIVE_NP was not being properly detected. [RT #44871]
4589.	[cleanup]	"configure -q" is now silent. [RT #44829]
4588.	[bug]	nsupdate could send queries for TKEY to the wrong server when using GSSAPI. Thanks to Tomas Hozza. [RT #39893]

(continues on next page)

(continued from previous page)

- 4587. [bug] named-checkzone failed to handle occulted data below DNAMEs correctly. [RT #44877]
- 4586. [func] dig, host and nslookup now use TCP for ANY queries. [RT #44687]
- 4585. [port] win32: Set CompileAS value. [RT #42474]
- 4584. [bug] A number of memory usage statistics were not properly reported when they exceeded 4G. [RT #44750]
- 4583. [func] "host -A" returns most records for a name but omits RRSIG, NSEC and NSEC3. (Thanks to Tony Finch.) [RT #43032]
- 4582. [security] 'rndc ""' could trigger a assertion failure in named. (CVE-2017-3138) [RT #44924]
- 4581. [port] Linux: Add getpid and getrandom to the list of system calls named uses for seccomp. [RT #44883]
- 4580. [bug] 4578 introduced a regression when handling CNAME to referral below the current domain. [RT #44850]
- 4579. [func] Logging channels and dnstap output files can now be configured with a "suffix" option, set to either "increment" or "timestamp", indicating whether to use incrementing numbers or timestamps as the file suffix when rolling over a log file. [RT #42838]
- 4578. [security] Some chaining (CNAME or DNAME) responses to upstream queries could trigger assertion failures. (CVE-2017-3137) [RT #44734]
- 4577. [func] Make qtype of resolver fuzzing packet configurable via command line. [RT #43540]
- 4576. [func] The RPZ implementation has been substantially refactored for improved performance and reliability. [RT #43449]
- 4575. [security] DNS64 with "break-dnssec yes;" can result in an assertion failure. (CVE-2017-3136) [RT #44653]
- 4574. [bug] Dig leaked memory with multiple +subnet options. [RT #44683]
- 4573. [func] Query logic has been substantially refactored (e.g. query\_find function has been split into smaller functions) for improved readability, maintainability

(continues on next page)

(continued from previous page)

		and testability. [RT #43929]
4572.	[func]	The "dnstap-output" option can now take "size" and "versions" parameters to indicate the maximum size a dnstap log file can grow before rolling to a new file, and how many old files to retain. [RT #44502]
4571.	[bug]	Out-of-tree builds of backtrace_test failed.
4570.	[cleanup]	named did not correctly fall back to the built-in initializing keys if the bind.keys file was present but empty. [RT #44531]
4569.	[func]	Store both local and remote addresses in dnstap logging, and modify dnstap-read output format to print them. [RT #43595]
4568.	[contrib]	Added a --with-bind option to the dnsperf configure script to specify BIND prefix path.
4567.	[port]	Call getprotobyname and getservbyname prior to calling chroot so that shared libraries get loaded. [RT #44537]
4566.	[func]	Query logging now includes the ECS option if one was included in the query. [RT #44476]
4565.	[cleanup]	The inline macro versions of isc_buffer_put*() did not implement automatic buffer reallocation. [RT #44216]
4564.	[maint]	Update the built in managed keys to include the upcoming root KSK. [RT #44579]
4563.	[bug]	Modified zones would occasionally fail to reload. [RT #39424]
4562.	[func]	Add additional memory statistics currently malloced and maxmalloced per memory context. [RT #43593]
4561.	[port]	Silence a warning in strict C99 compilers. [RT #44414]
4560.	[bug]	mdig: add -m option to enable memory debugging rather than having it on all the time. [RT #44509]
4559.	[bug]	openssl_link.c didn't compile if ISC_MEM_TRACKLINES was turned off. [RT #44509]
4558.	[bug]	Synthesised CNAME before matching DNAME was still being cached when it should not have been. [RT #44318]
4557.	[security]	Combining dns64 and rpz can result in dereferencing a NULL pointer (read). (CVE-2017-3135) [RT#44434]

(continues on next page)

(continued from previous page)

- 4556. [bug] Sending an EDNS Padding option using "dig +ednsopt" could cause a crash in dig. [RT #44462]
- 4555. [func] dig +ednsopt: EDNS options can now be specified by name in addition to numeric value. [RT #44461]
- 4554. [bug] Remove double unlock in dns\_dispatchmgr\_setudp. [RT #44336]
- 4553. [bug] Named could deadlock there were multiple changes to NSEC/NSEC3 parameters for a zone being processed at the same time. [RT #42770]
- 4552. [bug] Named could trigger a assertion when sending notify messages. [RT #44019]
- 4551. [test] Add system tests for integrity checks of MX and SRV records. [RT #43953]
- 4550. [cleanup] Increased the number of available master file output style flags from 32 to 64. [RT #44043]
- 4549. [func] Added support for the EDNS TCP Keepalive option (RFC 7828). [RT #42126]
- 4548. [func] Added support for the EDNS Padding option (RFC 7830). [RT #42094]
- 4547. [port] Add support for --enable-native-pkcs11 on the AEP Keyper HSM. [RT #42463]
- 4546. [func] Extend the use of const declarations. [RT #43379]
- 4545. [func] Expand YAML output from dnstap-read to include a detailed breakdown of the DNS message contents. [RT #43642]
- 4544. [bug] Add message/payload size to dnstap-read YAML output. [RT #43622]
- 4543. [bug] dns\_client\_startupupdate now delays sending the update request until isc\_app\_ctxrun has been called. [RT #43976]
- 4542. [func] Allow rndc to manipulate redirect zones with using -redirect as the zone name (use "-redirect." to manipulate a zone named "-redirect"). [RT #43971]
- 4541. [bug] rndc addzone should properly reject non master/slave zones. [RT #43665]

(continues on next page)

(continued from previous page)

- 4540. [bug] Correctly handle ecs entries in dns\_acl\_isinsecure.  
[RT #43601]
- 4539. [bug] Referencing a nonexistent zone with RPZ could lead  
to a assertion failure when configuring. [RT #43787]
- 4538. [bug] Call dns\_client\_startresolve from client->task.  
[RT #43896]
- 4537. [bug] Handle timeouts better in dig/host/nslookup. [RT #43576]
- 4536. [bug] ISC\_SOCKEVENTATTR\_USEMINMTU was not being cleared  
when reusing the event structure. [RT #43885]
- 4535. [bug] Address race condition in setting / testing of  
DNS\_REQUEST\_F\_SENDING. [RT #43889]
- 4534. [bug] Only set RD, RA and CD in QUERY responses. [RT #43879]
- 4533. [bug] dns\_client\_update should terminate on prerequisite  
failures (NXDOMAIN, YXDOMAIN, NXRRSET, YXRRSET)  
and also on BADZONE. [RT #43865]
- 4532. [contrib] Make gen-data-queryperf.py python 3 compatible.  
[RT #43836]
- 4531. [security] 'is\_zone' was not being properly updated by redirect2  
and subsequently preserved leading to an assertion  
failure. (CVE-2016-9778) [RT #43837]
- 4530. [bug] Change 4489 broke the handling of CNAME -> DNAME  
in responses resulting in SERVFAIL being returned.  
[RT #43779]
- 4529. [cleanup] Silence noisy log warning when DSCP probe fails  
due to firewall rules. [RT #43847]
- 4528. [bug] Only set the flag bits for the i/o we are waiting  
for on EPOLLERR or EPOLLHUP. [RT #43617]
- 4527. [doc] Support DocBook XSL Stylesheets v1.79.1. [RT #43831]
- 4526. [doc] Corrected errors and improved formatting of  
grammar definitions in the ARM. [RT #43739]
- 4525. [doc] Fixed outdated documentation on managed-keys.  
[RT #43810]
- 4524. [bug] The net zero test was broken causing IPv4 servers  
with addresses ending in .0 to be rejected. [RT #43776]
- 4523. [doc] Expand config doc for <querysource4> and

(continues on next page)

(continued from previous page)

		<querysource6>. [RT #43768]
4522.	[bug]	Handle big gaps in log file version numbers better. [RT #38688]
4521.	[cleanup]	Log it as an error if an entropy source is not found and there is no fallback available. [RT #43659]
4520.	[cleanup]	Alphabetize more of the grammar when printing it out. Fix unbalanced indenting. [RT #43755]
4519.	[port]	win32: handle ERROR_MORE_DATA. [RT #43534]
4518.	[func]	The "print-time" option in the logging configuration can now take arguments "local", "iso8601" or "iso8601-utc" to indicate the format in which the date and time should be logged. For backward compatibility, "yes" is a synonym for "local". [RT #42585]
4517.	[security]	Named could mishandle authority sections that were missing RRSIGs triggering an assertion failure. (CVE-2016-9444) [RT # 43632]
4516.	[bug]	isc_socketmgr_renderjson was missing from the windows build. [RT #43602]
4515.	[port]	FreeBSD: Find readline headers when they are in edit/readline/ instead of readline/. [RT #43658]
4514.	[port]	NetBSD: strip -WL, from ld command line. [RT #43204]
4513.	[cleanup]	Minimum Python versions are now 2.7 and 3.2. [RT #43566]
4512.	[bug]	win32: @GEOIP_INC@ missing from delv.vcxproj.in. [RT #43556]
4511.	[bug]	win32: mdig.exe-BNFT was missing Configure. [RT #43554]
4510.	[security]	Named mishandled some responses where covering RRSIG records are returned without the requested data resulting in a assertion failure. (CVE-2016-9147) [RT #43548]
4509.	[test]	Make the rrl system test more reliable on slower machines by using mdig instead of dig. [RT #43280]
4508.	[security]	Named incorrectly tried to cache TKEY records which could trigger a assertion failure when there was a class mismatch. (CVE-2016-9131) [RT #43522]

(continues on next page)

(continued from previous page)

- 4507. [bug] Named could incorrectly log 'allows updates by IP address, which is insecure' [RT #43432]
- 4506. [func] 'named-checkconf -l' will now list the zones found in named.conf. [RT #43154]
- 4505. [port] Use IP\_PMTUDISC\_OMIT if available. [RT #35494]
- 4504. [security] Allow the maximum number of records in a zone to be specified. This provides a control for issues raised in CVE-2016-6170. [RT #42143]
- 4503. [cleanup] "make uninstall" now removes files installed by BIND. (This currently excludes Python files due to lack of support in setup.py.) [RT #42192]
- 4502. [func] Report multiple and experimental options when printing grammar. [RT #43134]
- 4501. [placeholder]
- 4500. [bug] Support modifier I64 in isc\_\_print\_printf. [RT #43526]
- 4499. [port] MacOSX: silence deprecated function warning by using arc4random\_stir() when available instead of arc4random\_addrandom(). [RT #43503]
- 4498. [test] Simplify prerequisite checks in system tests. [RT #43516]
- 4497. [port] Add support for OpenSSL 1.1.0. [RT #41284]
- 4496. [func] dig: add +idnout to control whether labels are display in punycode or not. Requires idn support to be enabled at compile time. [RT #43398]
- 4495. [bug] A isc\_mutex\_init call was not being checked. [RT #43391]
- 4494. [bug] Look for <editline/readline.h>. [RT #43429]
- 4493. [bug] bin/tests/system/dyndb/driver/Makefile.in should use SO\_TARGETS. [RT# 43336]
- 4492. [bug] irs\_resconf\_load failed to initialize sortlistnxt causing bad writes if resolv.conf contained a sortlist directive. [RT #43459]
- 4491. [bug] Improve message emitted when testing whether sendmsg works with TOS/TCLASS fails. [RT #43483]
- 4490. [maint] Added AAAA (2001:500:12::d0d) for G.ROOT-SERVERS.NET.

(continues on next page)

(continued from previous page)

- 4489. [security] It was possible to trigger assertions when processing a response containing a DNAME answer. (CVE-2016-8864) [RT #43465]
- 4488. [port] Darwin: use -framework for Kerberos. [RT #43418]
- 4487. [test] Make system tests work on Windows. [RT #42931]
- 4486. [bug] Look in \$prefix/lib/pythonX.Y/site-packages for the python modules we install. [RT #43330]
- 4485. [bug] Failure to find readline when requested should be fatal to configure. [RT #43328]
- 4484. [func] Check prefixes in acls to make sure the address and prefix lengths are consistent. Warn only in BIND 9.11 and earlier. [RT #43367]
- 4483. [bug] Address use before require check and remove extraneous dns\_message\_gettsigkey call in dns\_tsig\_sign. [RT #43374]
- 4482. [cleanup] Change #4455 was incomplete. [RT #43252]
- 4481. [func] dig: make +class, +crypto, +multiline, +rrcomments, +onesoa, +qr, +ttlid, +ttlunits and -u per lookup rather than global. [RT #42450]
- 4480. [placeholder]
- 4479. [placeholder]
- 4478. [func] Add +continue option to mdig, allow continue on socket errors. [RT #43281]
- 4477. [test] Fix mkeys test timing issues. [RT #41028]
- 4476. [test] Fix reclimit test on slower machines. [RT #43283]
- 4475. [doc] Update named-checkconf documentation. [RT #43153]
- 4474. [bug] win32: call WSASStartup in fromtext\_in\_wks so that getprotobyname and getservbyname work. [RT #43197]
- 4473. [bug] Only call fsync / \_commit on regular files. [RT #43196]
- 4472. [bug] Named could fail to find the correct NSEC3 records when a zone was updated between looking for the answer and looking for the NSEC3 records proving nonexistence of the answer. [RT #43247]

--- 9.11.0 released ---

--- 9.11.0rc3 released ---

- 4471. [cleanup] Render client/query logging format consistent for ease of log file parsing. (Note that this affects "querylog" format: there is now an additional field indicating the client object address.) [RT #43238]
- 4470. [bug] Reset message with intent parse before calling dns\_dispatch\_getnext. [RT #43229]
- 4469. [placeholder]

--- 9.11.0rc2 released ---

- 4468. [bug] Address ECS option handling issues. [RT #43191]
- 4467. [security] It was possible to trigger an assertion when rendering a message. (CVE-2016-2776) [RT #43139]
- 4466. [bug] Interface scanning didn't work on a Windows system without a non local IPv6 addresses. [RT #43130]
- 4465. [bug] Don't use "%z" as Windows doesn't support it. [RT #43131]
- 4464. [bug] Fix windows python support. [RT #43173]
- 4463. [bug] The dnstap system test failed on some systems. [RT #43129]
- 4462. [bug] Don't describe a returned EDNS COOKIE as "good" when there isn't a valid server cookie. [RT #43167]
- 4461. [bug] win32: not all external data was properly marked as external data for windows dll. [RT #43161]

--- 9.11.0rc1 released ---

- 4460. [test] Add system test for dnstap using unix domain sockets. [RT #42926]
- 4459. [bug] TCP client objects created to handle pipeline queries were not cleaned up correctly, causing uncontrolled memory growth. [RT #43106]
- 4458. [cleanup] Update assertions to be more correct, and also remove use of a reserved word. [RT #43090]
- 4457. [maint] Added AAAA (2001:500:a8::e) for E.ROOT-SERVERS.NET.

(continues on next page)

(continued from previous page)

- 4456. [doc] Add DOCTYPE and lang attribute to <html> tags.  
[RT #42587]
- 4455. [cleanup] Allow dyndb modules to correctly log the filename  
and line number when processing configuration text  
from named.conf. [RT #43050]
- 4454. [bug] 'rndc dnstap -reopen' had a race issue. [RT #43089]
- 4453. [bug] Prefetching of DS records failed to update their  
RRSIGs. [RT #42865]
- 4452. [bug] The default key manager policy file is now  
<sysdir>/dnssec-policy.conf (usually  
/etc/dnssec-policy.conf). [RT #43064]
- 4451. [cleanup] Log more useful information if a PKCS#11 provider  
library cannot be loaded. [RT #43076]
- 4450. [port] Provide more nuanced HSM support which better matches  
the specific PKCS11 providers capabilities. [RT #42458]
- 4449. [test] Fix catalog zones test on slower systems. [RT #42997]
- 4448. [bug] win32: ::1 was not being found when iterating  
interfaces. [RT #42993]
- 4447. [tuning] Allow the fstrm\_iothr\_init() options to be set using  
named.conf to control how dnstap manages the data  
flow. [RT #42974]
- 4446. [bug] The cache\_find() and \_findrdataset() functions  
could find rdatasets that had been marked stale.  
[RT #42853]
- 4445. [cleanup] isc\_errno\_toresult() can now be used to call the  
formerly private function isc\_\_errno2result().  
[RT #43050]
- 4444. [bug] Fixed some issues related to dyndb: A bug caused  
braces to be omitted when passing configuration text  
from named.conf to a dyndb driver, and there was a  
use-after-free in the sample dyndb driver. [RT #43050]
- 4443. [func] Set TCP\_MAXSEG in addition to IPV6\_USE\_MIN\_MTU on  
TCP sockets. [RT #42864]
- 4442. [bug] Fix RPZ CIDR tree insertion bug that corrupted  
tree data structure with overlapping networks  
(longest prefix match was ineffective).  
[RT #43035]

(continues on next page)

(continued from previous page)

4441.	[cleanup]	Alphabetize host's help output. [RT #43031]
4440.	[func]	Enable TCP fast open support when available on the server side. [RT #42866]
4439.	[bug]	Address race conditions getting ownernames of nodes. [RT #43005]
4438.	[func]	Use LIFO rather than FIFO when processing startup notify and refresh queries. [RT #42825]
4437.	[func]	Minimal-responses now has two additional modes no-auth and no-auth-recursive which suppress adding the NS records to the authority section as well as the associated address records for the nameservers. [RT #42005]
4436.	[func]	Return TLSA records as additional data for MX and SRV lookups. [RT #42894]
4435.	[tuning]	Only set IPV6_USE_MIN_MTU for UDP when the message will not fit into a single IPv4 encapsulated IPv6 UDP packet when transmitted over a Ethernet link. [RT #42871]
4434.	[protocol]	Return EDNS EXPIRE option for master zones in addition to slave zones. [RT #43008]
4433.	[cleanup]	Report an error when passing an invalid option or view name to "rndc dumpdb". [RT #42958]
4432.	[test]	Hide rndc output on expected failures in logfileconfig system test. [RT #27996]
4431.	[bug]	named-checkconf now checks the rate-limit clause. [RT #42970]
4430.	[bug]	Lwresd died if a search list was not defined. Found by 0x710DDDD At Alibaba Security. [RT #42895]
4429.	[bug]	Address potential use after free on fclose() error. [RT #42976]
4428.	[bug]	The "test dispatch getnext" unit test could fail in a threaded build. [RT #42979]
4427.	[bug]	The "query" and "response" parameters to the "dnstap" option had their functions reversed.

--- 9.11.0b3 released ---

4426.	[bug]	Addressed Coverity warnings. [RT #42908]
-------	-------	--

(continues on next page)

(continued from previous page)

- 4425. [bug] arpaname, dnstap-read and named-rrchecker were not being installed into \${prefix}/bin. Tidy up installation issues with CHANGE 4421. [RT #42910]
- 4424. [experimental] Named now sends \_ta-XXXX.<trust-anchor>/NULL queries to provide feedback to the trust-anchor administrators about how key rollovers are progressing as per draft-ietf-dnsop-edns-key-tag-02. This can be disabled using 'trust-anchor-telemetry no;'. [RT #40583]
- 4423. [maint] Added missing IPv6 address 2001:500:84::b for B.ROOT-SERVERS.NET. [RT #42898]
- 4422. [port] Silence clang warnings in dig.c and dighost.c. [RT #42451]
- 4421. [func] When built with LMDB (Lightning Memory-mapped Database), named will now use a database to store the configuration for zones added by "rndc addzone" instead of using a flat NZF file. This improves performance of "rndc delzone" and "rndc modzone" significantly. Existing NZF files will automatically be converted to NZD databases. To view the contents of an NZD or to roll back to NZF format, use "named-nzd2nzf". To disable this feature, use "configure --without-lmdb". [RT #39837]
- 4420. [func] nslookup now looks for AAAA as well as A by default. [RT #40420]
- 4419. [bug] Don't cause undefined result if the label of an entry in catalog zone is changed. [RT #42708]
- 4418. [bug] Fix a compiler warning in GSSAPI code. [RT #42879]
- 4417. [bug] dnssec-keymgr could fail to create successor keys if the prepublication interval was set to a value smaller than the default. [RT #42820]
- 4416. [bug] dnssec-keymgr: Domain names in policy files could fail to match due to trailing dots. [RT #42807]
- 4415. [bug] dnssec-keymgr: Expired/deleted keys were not always excluded. [RT #42884]
- 4414. [bug] Corrected a bug in the MIPS implementation of isc\_atomic\_xadd(). [RT #41965]
- 4413. [bug] GSSAPI negotiation could fail if GSS\_S\_CONTINUE\_NEEDED

(continues on next page)

(continued from previous page)

was returned. [RT #42733]

--- 9.11.0b2 released ---

- 4412. [cleanup] Make fixes for GCC 6. ISC\_OFFSET\_MAXIMUM macro was removed. [RT #42721]
- 4411. [func] "rndc dnstap -roll" automatically rolls the dnstap output file; the previous version is saved with ".0" suffix, and earlier versions with ".1" and so on. An optional numeric argument indicates how many prior files to save. [RT #42830]
- 4410. [bug] Address use after free and memory leak with dnstap. [RT #42746]
- 4409. [bug] DNS64 should exclude mapped addresses by default when an exclude acl is not defined. [RT #42810]
- 4408. [func] Continue waiting for expected response when we the response we get does not match the request. [RT #41026]
- 4407. [performance] Use GCC builtin for clz in RPZ lookup code. [RT #42818]
- 4406. [security] getrrsetbyname with a non absolute name could trigger an infinite recursion bug in lwresd and named with lwres configured if when combined with a search list entry the resulting name is too long. (CVE-2016-2775) [RT #42694]
- 4405. [bug] Change 4342 introduced a regression where you could not remove a delegation in a NSEC3 signed zone using OPTOUT via nsupdate. [RT #42702]
- 4404. [misc] Allow krb5-config to be used when configuring gssapi. [RT #42580]
- 4403. [bug] Rename variables and arguments that shadow: basename, clone and gai\_error.
- 4402. [bug] protoc-c is now a hard requirement for --enable-dnstap.

--- 9.11.0b1 released ---

- 4401. [misc] Change LICENSE to MPL 2.0.
- 4400. [bug] ttl policy was not being inherited in policy.py. [RT #42718]
- 4399. [bug] policy.py 'ECCGOST', 'ECDSAP256SHA256', and

(continues on next page)

(continued from previous page)

		'ECDSAP384SHA384' don't have settable keysize. [RT #42718]
4398.	[bug]	Correct spelling of ECDSAP256SHA256 in policy.py. [RT #42718]
4397.	[bug]	Update Windows python support. [RT #42538]
4396.	[func]	dnssec-keymgr now takes a '-r randomfile' option. [RT #42455]
4395.	[bug]	Improve out-of-tree installation of python modules. [RT #42586]
4394.	[func]	Add rndc command "dnstap-reopen" to close and reopen dnstap output files. [RT #41803]
4393.	[bug]	Address potential NULL pointer dereferences in dnstap code.
4392.	[func]	Collect statistics for RSSAC02v3 traffic-volume, traffic-sizes and rcode-volume reporting. [RT #41475]
4391.	[contrib]	Fix leaks in contrib DLZ code. [RT #42707]
4390.	[doc]	Description of masters with TSIG, allow-query and allow-transfer options in catalog zones. [RT #42692]
4389.	[test]	Rewritten test suite for catalog zones. [RT #42676]
4388.	[func]	Support for master entries with TSIG keys in catalog zones. [RT #42577]
4387.	[bug]	Change 4336 was not complete leading to SERVFAIL being return as NS records expired. [RT #42683]
4386.	[bug]	Remove shadowed overmem function/variable. [RT #42706]
4385.	[func]	Add support for allow-query and allow-transfer ACLs to catalog zones. [RT #42578]
4384.	[bug]	Change 4256 accidentally disabled logging of the rndc command. [RT #42654]
4383.	[bug]	Correct spelling error in stats channel description of "EDNS client subnet option received". [RT #42633]
4382.	[bug]	rndc {addzone,modzone,delzone,showzone} should all compare the zone name using a canonical format. [RT #42630]
4381.	[bug]	Missing "zone-directory" option in catalog zone

(continues on next page)

(continued from previous page)

definition caused BIND to crash. [RT #42579]

--- 9.11.0a3 released ---

- 4380. [experimental] Added a "zone-directory" option to "catalog-zones" syntax, allowing local masterfiles for slaves that are provisioned by catalog zones to be stored in a directory other than the server's working directory. [RT #42527]
- 4379. [bug] An INSIST could be triggered if a zone contains RRSIG records with expiry fields that loop using serial number arithmetic. [RT #40571]
- 4378. [contrib] #include <isc/string.h> for strlcat in zone2ldap.c. [RT #42525]
- 4377. [bug] Don't reuse zero TTL responses beyond the current client set (excludes ANY/SIG/RRSIG queries). [RT #42142]
- 4376. [experimental] Added support for Catalog Zones, a new method for provisioning secondary servers in which a list of zones to be served is stored in a DNS zone and can be propagated to slaves via AXFR/IXFR. [RT #41581]
- 4375. [func] Add support for automatic reallocation of isc\_buffer to isc\_buffer\_put\* functions. [RT #42394]
- 4374. [bug] Use SAVE/RESTORE macros in query.c to reduce the probability of reference counting errors as seen in 4365. [RT #42405]
- 4373. [bug] Address undefined behavior in getaddrinfo. [RT #42479]
- 4372. [bug] Address undefined behavior in libt\_api. [RT #42480]
- 4371. [func] New "minimal-any" option reduces the size of UDP responses for qtype ANY by returning a single arbitrarily selected RRset instead of all RRsets. Thanks to Tony Finch. [RT #41615]
- 4370. [bug] Address python3 compatibility issues with RNDC module. [RT #42499] [RT #42506]

--- 9.11.0a2 released ---

- 4369. [bug] Fix 'make' and 'make install' out-of-tree python support. [RT #42484]
- 4368. [bug] Fix a crash when calling "rndc stats" on some

(continues on next page)

(continued from previous page)

		Windows builds because some Visual Studio compilers generated crashing code for the "%z" printf() format specifier. [RT #42380]
4367.	[bug]	Remove unnecessary assignment of loadtime in zone_touched. [RT #42440]
4366.	[bug]	Address race condition when updating rbtnode bit fields. [RT #42379]
4365.	[bug]	Address zone reference counting errors involving nxdomain-redirect. [RT #42258]
4364.	[port]	freebsd: add -Wl,-E to loader flags [RT #41690]
4363.	[port]	win32: Disable explicit triggering UAC when running BINDInstall.
4362.	[func]	Changed rndc reconfig behavior so that newly added zones are loaded asynchronously and the loading does not block the server. [RT #41934]
4361.	[cleanup]	Where supported, file modification times returned by isc_file_getmodtime() are now accurate to the nanosecond. [RT #41968]
4360.	[bug]	Silence spurious 'bad key type' message when there is a existing TSIG key. [RT #42195]
4359.	[bug]	Inherited 'also-notify' lists were not being checked by named-checkconf. [RT #42174]
4358.	[test]	Added American Fuzzy Lop harness that allows feeding fuzzed packets into BIND. [RT #41723]
4357.	[func]	Add the python RNDC module. [RT #42093]
4356.	[func]	Add the ability to specify whether to wait for nameserver addresses to be looked up or not to RPZ with a new modifying directive 'nsip-wait-recurse'. [RT #35009]
4355.	[func]	"pkcs11-list" now displays the extractability attribute of private or secret keys stored in an HSM, as either "true", "false", or "never" Thanks to Daniel Stirnimann. [RT #36557]
4354.	[bug]	Check that the received HMAC length matches the expected length prior to check the contents on the control channel. This prevents a OOB read error. This was reported by Lian Yihan, <lianyihan@360.cn>.

(continues on next page)

(continued from previous page)

		[RT #42215]
4353.	[cleanup]	Update PKCS#11 header files. [RT #42175]
4352.	[cleanup]	The ISC DNSSEC Lookaside Validation (DLV) service is scheduled to be disabled in 2017. A warning is now logged when named is configured to use it, either explicitly or via "dnssec-lookaside auto;" [RT #42207]
4351.	[bug]	'dig +noignore' didn't work. [RT #42273]
4350.	[contrib]	Declare result in dlz_filesystem_dynamic.c.
4349.	[contrib]	kasp2policy: A python script to create a DNSSEC policy file from an OpenDNSSEC KASP XML file.
4348.	[func]	dnssec-keymgr: A new python-based DNSSEC key management utility, which reads a policy definition file and can create or update DNSSEC keys as needed to ensure that a zone's keys match policy, roll over correctly on schedule, etc. Thanks to Sebastian Castro for assistance in development. [RT #39211]
4347.	[port]	Corrected a build error on x86_64 Solaris. [RT #42150]
4346.	[bug]	Fixed a regression introduced in change #4337 which caused signed domains with revoked KSKs to fail validation. [RT #42147]
4345.	[contrib]	perftcpdns mishandled the return values from clock_nanosleep. [RT #42131]
4344.	[port]	Address openssl version differences. [RT #42059]
4343.	[bug]	dns_dnssec_syncupdate mis-declared in <dns/dnssec.h>. [RT #42090]
4342.	[bug]	'rndc flushtree' could fail to clean the tree if there wasn't a node at the specified name. [RT #41846]

		--- 9.11.0a1 released ---
4341.	[bug]	Correct the handling of ECS options with address family 0. [RT #41377]
4340.	[performance]	Implement adaptive read-write locks, reducing the overhead of locks that are only held briefly. [RT #37329]
4339.	[test]	Use "mdig" to test pipelined queries. [RT #41929]

(continues on next page)

(continued from previous page)

- 4338. [bug] Reimplement change 4324 as it wasn't properly doing all the required book keeping. [RT #41941]
- 4337. [bug] The previous change exposed a latent flaw in key refresh queries for managed-keys when a cached DNSKEY had TTL 0. [RT #41986]
- 4336. [bug] Don't emit records with zero ttl unless the records were learnt with a zero ttl. [RT #41687]
- 4335. [bug] zone->view could be detached too early. [RT #41942]
- 4334. [func] 'named -V' now reports zlib version. [RT #41913]
- 4333. [maint] L.ROOT-SERVERS.NET is now 199.7.83.42 and 2001:500:9f::42.
- 4332. [placeholder]
- 4331. [func] When loading managed signed zones detect if the RRSIG's inception time is in the future and regenerate the RRSIG immediately. [RT #41808]
- 4330. [protocol] Identify the PAD option as "PAD" when printing out a message.
- 4329. [func] Warn about a common misconfiguration when forwarding RFC 1918 zones. [RT #41441]
- 4328. [performance] Add dns\_name\_fromwire() benchmark test. [RT #41694]
- 4327. [func] Log query and depth counters during fetches when querytrace (./configure --enable-querytrace) is enabled (helps in diagnosing). [RT #41787]
- 4326. [protocol] Add support for AVC. [RT #41819]
- 4325. [func] Add a line to "rndc status" indicating the hostname and operating system details. [RT #41610]
- 4324. [bug] When deleting records from a zone database, interior nodes could be left empty but not deleted, damaging search performance afterward. [RT #40997]
- 4323. [bug] Improve HTTP header processing on statschannel. [RT #41674]
- 4322. [security] Duplicate EDNS COOKIE options in a response could trigger an assertion failure. (CVE-2016-2088) [RT #41809]
- 4321. [bug] Zones using mapped files containing out-of-zone data

(continues on next page)

(continued from previous page)

		could return SERVFAIL instead of the expected NODATA or NXDOMAIN results. [RT #41596]
4320.	[bug]	Insufficient memory allocation when handling "none" ACL could cause an assertion failure in named when parsing ACL configuration. [RT #41745]
4319.	[security]	Fix resolver assertion failure due to improper DNAME handling when parsing fetch reply messages. (CVE-2016-1286) [RT #41753]
4318.	[security]	Malformed control messages can trigger assertions in named and rndc. (CVE-2016-1285) [RT #41666]
4317.	[bug]	Age all unused servers on fetch timeout. [RT #41597]
4316.	[func]	Add option to tools to print RRs in unknown presentation format [RT #41595].
4315.	[bug]	Check that configured view class isn't a meta class. [RT #41572].
4314.	[contrib]	Added 'dnssperf-2.1.0.0-1', a set of performance testing tools provided by Nominum, Inc.
4313.	[bug]	Handle ns_client_replace failures in test mode. [RT #41190]
4312.	[bug]	dig's unknown DNS and EDNS flags (MBZ value) logging was not consistent. [RT #41600]
4311.	[bug]	Prevent "rndc delzone" from being used on response-policy zones. [RT #41593]
4310.	[performance]	Use __builtin_expect() where available to annotate conditions with known behavior. [RT #41411]
4309.	[cleanup]	Remove the spurious "none" filename from log messages when processing built-in configuration. [RT #41594]
4308.	[func]	Added operating system details to "named -V" output. [RT #41452]
4307.	[bug]	"dig +subnet" and "mdig +subnet" could send incorrectly-formatted Client Subnet options if the prefix length was not divisible by 8. Also fixed a memory leak in "mdig". [RT #45178]
4306.	[maint]	Added a PKCS#11 openssl patch supporting version 1.0.2f [RT #38312]
4305.	[bug]	dnssec-signzone was not removing unnecessary rrsigs

(continues on next page)

(continued from previous page)

		from the zone's apex. [RT #41483]
4304.	[port]	xfer system test failed as 'tail -n +value' is not portable. [RT #41315]
4303.	[bug]	"dig +subnet" was unable to send a prefix length of zero, as it was incorrectly changed to 32 for v4 prefixes or 128 for v6 prefixes. In addition to fixing this, "dig +subnet=0" has been added as a short form for 0.0.0.0/0. The same changes have also been made in "mdig". [RT #41553]
4302.	[port]	win32: fixed a build error in VS 2015. [RT #41426]
4301.	[bug]	dnssec-settime -p [DP]sync was not working. [RT #41534]
4300.	[bug]	A flag could be set in the wrong field when setting up non-recursive queries; this could cause the SERVFAIL cache to cache responses it shouldn't. New querytrace logging has been added which identified this error. [RT #41155]
4299.	[bug]	Check that exactly totalen bytes are read when reading a RRset from raw files in both single read and incremental modes. [RT #41402]
4298.	[bug]	dns_rpz_add errors in loadzone were not being propagated up the call stack. [RT #41425]
4297.	[test]	Ensure delegations in RPZ zones fail robustly. [RT #41518]
4296.	[bug]	TCP packet sizes were calculated incorrectly in the stats channel; they could be counted in the wrong histogram bucket. [RT #40587]
4295.	[bug]	An unchecked result in dns_message_pseudosectiontotext() could allow incorrect text formatting of EDNS EXPIRE options. [RT #41437]
4294.	[bug]	Fixed a regression in which "rndc stop -p" failed to print the PID. [RT #41513]
4293.	[bug]	Address memory leak on priming query creation failure. [RT #41512]
4292.	[placeholder]	
4291.	[cleanup]	Added a required include to dns/forward.h. [RT #41474]
4290.	[func]	The timers returned by the statistics channel (indicating current time, server boot time, and

(continues on next page)

(continued from previous page)

		most recent reconfiguration time) are now reported with millisecond accuracy. [RT #40082]
4289.	[bug]	The server could crash due to memory being used after it was freed if a zone transfer timed out. [RT #41297]
4288.	[bug]	Fixed a regression in resolver.c:possibly_mark() which caused known-bogus servers to be queried anyway. [RT #41321]
4287.	[bug]	Silence an overly noisy log message when message parsing fails. [RT #41374]
4286.	[security]	render_ecs errors were mishandled when printing out a OPT record resulting in a assertion failure. (CVE-2015-8705) [RT #41397]
4285.	[security]	Specific APL data could trigger a INSIST. (CVE-2015-8704) [RT #41396]
4284.	[bug]	Some GeoIP options were incorrectly documented using abbreviated forms which were not accepted by named. The code has been updated to allow both long and abbreviated forms. [RT #41381]
4283.	[bug]	OPENSSL_config is no longer re-callable. [RT #41348]
4282.	[func]	'dig +[no]mapped' determine whether the use of mapped IPv4 addresses over IPv6 is permitted or not. The default is +mapped. [RT #41307]
4281.	[bug]	Teach dns_message_totext about BADCOOKIE. [RT #41257]
4280.	[performance]	Use optimal message sizes to improve compression in AXFRs. This reduces network traffic. [RT #40996]
4279.	[test]	Don't use fixed ports when unit testing. [RT #41194]
4278.	[bug]	'delv +short +[no]split[=##]' didn't work as expected. [RT #41238]
4277.	[performance]	Improve performance of the RBT, the central zone datastructure: The aux hashtable was improved, hash function was updated to perform more uniform mapping, uppernode was added to dns_rbtnode, and other cleanups and performance improvements were made. [RT #41165]
4276.	[protocol]	Add support for SMIMEA. [RT #40513]
4275.	[performance]	Lazily initialize dns_compress->table only when

(continues on next page)

(continued from previous page)

- compression is enabled. [RT #41189]
- 4274. [performance] Speed up typemap processing from text. [RT #41196]
- 4273. [bug] Only call dns\_test\_begin() and dns\_test\_end() once each in nsec3\_test as it fails with GOST if called multiple times.
- 4272. [bug] dig: the +norrcomments option didn't work with +multi. [RT #41234]
- 4271. [test] Unit tests could deadlock in isc\_\_taskmgr\_pause(). [RT #41235]
- 4270. [security] Update allowed OpenSSL versions as named is potentially vulnerable to CVE-2015-3193.
- 4269. [bug] Zones using "map" format master files currently don't work as policy zones. This limitation has now been documented; attempting to use such zones in "response-policy" statements is now a configuration error. [RT #38321]
- 4268. [func] "rndc status" now reports the path to the configuration file. [RT #36470]
- 4267. [test] Check sdlz error handling. [RT #41142]
- 4266. [placeholder]
- 4265. [bug] Address unchecked isc\_mem\_get calls. [RT #41187]
- 4264. [bug] Check const of strchr/strchr assignments match argument's const status. [RT #41150]
- 4263. [contrib] Address compiler warnings in mysqldyn module. [RT #41130]
- 4262. [bug] Fixed a bug in epoll socket code that caused sockets to not be registered for ready notification in some cases, causing named to not read from or write to them, resulting in what appear to the user as blocked connections. [RT #41067]
- 4261. [maint] H.ROOT-SERVERS.NET is 198.97.190.53 and 2001:500:1::53. [RT #40556]
- 4260. [security] Insufficient testing when parsing a message allowed records with an incorrect class to be accepted, triggering a REQUIRE failure when those records were subsequently cached. (CVE-2015-8000) [RT #40987]

(continues on next page)

(continued from previous page)

- 4259. [func] Add an option for non-destructive control channel access using a "read-only" clause. In such cases, a restricted set of rndc commands are allowed for querying information from named. [RT #40498]
- 4258. [bug] Limit rndc query message sizes to 32 KiB. This should not break any legitimate rndc commands, but will prevent a rogue rndc query from allocating too much memory. [RT #41073]
- 4257. [cleanup] Python scripts reported incorrect version. [RT #41080]
- 4256. [bug] Allow rndc command arguments to be quoted so as to allow spaces. [RT #36665]
- 4255. [performance] Add 'message-compression' option to disable DNS compression in responses. [RT #40726]
- 4254. [bug] Address missing lock when getting zone's serial. [RT #41072]
- 4253. [security] Address fetch context reference count handling error on socket error. (CVE-2015-8461) [RT#40945]
- 4252. [func] Add support for automating the generation CDS and CDNSKEY rrsets to named and dnssec-signzone. [RT #40424]
- 4251. [bug] NTAs were deleted when the server was reconfigured or reloaded. [RT #41058]
- 4250. [func] Log the TSIG key in use during inbound zone transfers. [RT #41075]
- 4249. [func] Improve error reporting of TSIG / SIG(0) records in the wrong location. [RT #41030]
- 4248. [performance] Add an isc\_atomic\_storeq() function, use it in stats counters to improve performance. [RT #39972] [RT #39979]
- 4247. [port] Require both HAVE\_JSON and JSON\_C\_VERSION to be defined to report json library version. [RT #41045]
- 4246. [test] Ensure the statschannel system test runs when BIND is not built with libjson. [RT #40944]
- 4245. [placeholder]
- 4244. [bug] The parser was not reporting that use-ixfr is obsolete.

(continues on next page)

(continued from previous page)

		[RT #41010]
4243.	[func]	Improved stats reporting from Timothe Litt. [RT #38941]
4242.	[bug]	Replace the client if not already replaced when prefetching. [RT #41001]
4241.	[doc]	Improved the TSIG, TKEY, and SIG(0) sections in the ARM. [RT #40955]
4240.	[port]	Fix LibreSSL compatibility. [RT #40977]
4239.	[func]	Changed default servfail-ttl value to 1 second from 10. Also, the maximum value is now 30 instead of 300. [RT #37556]
4238.	[bug]	Don't send to servers on net zero (0.0.0.0/8). [RT #40947]
4237.	[doc]	Upgraded documentation toolchain to use DocBook 5 and dblatex. [RT #40766]
4236.	[performance]	On machines with 2 or more processors (CPU), the default value for the number of UDP listeners has been changed to the number of detected processors minus one. [RT #40761]
4235.	[func]	Added support in named for "dnstap", a fast method of capturing and logging DNS traffic, and a new command "dnstap-read" to read a dnstap log file. Use "configure --enable-dnstap" to enable this feature (note that this requires libprotobuf-c and libfstrm). See the ARM for configuration details.  Thanks to Robert Edmonds of Farsight Security. [RT #40211]
4234.	[func]	Add deflate compression in statistics channel HTTP server. [RT #40861]
4233.	[test]	Add tests for CDS and CDNSKEY with delegation-only. [RT #40597]
4232.	[contrib]	Address unchecked memory allocation calls in query-loc and zone2ldap. [RT #40789]
4231.	[contrib]	Address unchecked calloc call in dlz_mysql_dyn_mod.c. [RT #40840]
4230.	[contrib]	dlz_wildcard_dynamic.c:dlz_create could return a uninitialized result. [RT #40839]

(continues on next page)

(continued from previous page)

- 4229. [bug] A variable could be used uninitialized in dns\_update\_signaturesinc. [RT #40784]
- 4228. [bug] Address race condition in dns\_client\_destroyrestrans. [RT #40605]
- 4227. [bug] Silence static analysis warnings. [RT #40828]
- 4226. [bug] Address a theoretical shutdown race in zone.c:notify\_send\_queue(). [RT #38958]
- 4225. [port] freebsd/openbsd: Use '\${CC} -shared' for building shared libraries. [RT #39557]
- 4224. [func] Added support for "dyndb", a new interface for loading zone data from an external database, developed by Red Hat for the FreeIPA project.  
  
 DynDB drivers fully implement the BIND database API, and are capable of significantly better performance and functionality than DLZ drivers, while taking advantage of advanced database features not available in BIND such as multi-master replication.  
  
 Thanks to Adam Tkac and Petr Spacek of Red Hat. [RT #35271]
- 4223. [func] Add support for setting max-cache-size to percentage of available physical memory, set default to 90%. [RT #38442]
- 4222. [func] Bias IPv6 servers when selecting the next server to query. [RT #40836]
- 4221. [bug] Resource leak on DNS\_R\_NXDOMAIN in fctx\_create. [RT #40583]
- 4220. [doc] Improve documentation for zone-statistics. [RT #36955]
- 4219. [bug] Set event->result to ISC\_R\_WOULDBLOCK on EWOULDBLOCK, EGAIN when these soft error are not retried for isc\_socket\_send\*().
- 4218. [bug] Potential null pointer dereference on out of memory if mmap is not supported. [RT #40777]
- 4217. [protocol] Add support for CSYNC. [RT #40532]
- 4216. [cleanup] Silence static analysis warnings. [RT #40649]

(continues on next page)

(continued from previous page)

4215.	[bug]	nsupdate: skip to next request on GSSTKEY create failure. [RT #40685]
4214.	[protocol]	Add support for TALINK. [RT #40544]
4213.	[bug]	Don't reuse a cache across multiple classes. [RT #40205]
4212.	[func]	Re-query if we get a bad client cookie returned over UDP. [RT #40748]
4211.	[bug]	Ensure that lwresd gets at least one task to work with if enabled. [RT #40652]
4210.	[cleanup]	Silence use after free false positive. [RT #40743]
4209.	[bug]	Address resource leaks in dlz modules. [RT #40654]
4208.	[bug]	Address null pointer dereferences on out of memory. [RT #40764]
4207.	[bug]	Handle class mismatches with raw zone files. [RT #40746]
4206.	[bug]	contrib: fixed a possible NULL dereference in DLZ wildcard module. [RT #40745]
4205.	[bug]	'named-checkconf -p' could include unwanted spaces when printing tuples with unset optional fields. [RT #40731]
4204.	[bug]	'dig +trace' failed to lookup the correct type if the initial root NS query was retried. [RT #40296]
4203.	[test]	The rrchecker system test now tests conversion to and from unknown-type format. [RT #40584]
4202.	[bug]	isccc_cc_fromwire() could return an incorrect result. [RT #40614]
4201.	[func]	The default preferred-glue is now the address record type of the transport the query was received over. [RT #40468]
4200.	[cleanup]	win32: update BINDinstall to be BIND release independent. [RT #38915]
4199.	[protocol]	Add support for NINFO, RKEY, SINK, TA. [RT #40545] [RT #40547] [RT #40561] [RT #40563]
4198.	[placeholder]	

(continues on next page)

(continued from previous page)

- 4197. [bug] 'named-checkconf -z' didn't handle 'in-view' clauses.  
[RT #40603]
- 4196. [doc] Improve how "enum + other" types are documented.  
[RT #40608]
- 4195. [bug] 'max-zone-ttl unlimited;' was broken. [RT #40608]
- 4194. [bug] named-checkconf -p failed to properly print a port  
range. [RT #40634]
- 4193. [bug] Handle broken servers that return BADVERS incorrectly.  
[RT #40427]
- 4192. [bug] The default rrset-order of random was not always being  
applied. [RT #40456]
- 4191. [protocol] Accept DNS-SD non LDH PTR records in reverse zones  
as per RFC 6763. [RT #37889]
- 4190. [protocol] Accept Active Directory gc.\_msdcs.<forest> name as  
valid with check-names. <forest> still needs to be  
LDH. [RT #40399]
- 4189. [cleanup] Don't exit on overly long tokens in named.conf.  
[RT #40418]
- 4188. [bug] Support HTTP/1.0 client properly on the statistics  
channel. [RT #40261]
- 4187. [func] When any RR type implementation doesn't  
implement totext() for the RDATA's wire  
representation and returns ISC\_R\_NOTIMPLEMENTED,  
such RDATA is now printed in unknown  
presentation format (RFC 3597). RR types affected  
include LOC(29) and APL(42). [RT #40317].
- 4186. [bug] Fixed an RPZ bug where a QNAME would be matched  
against a policy RR with wildcard owner name  
(trigger) where the QNAME was the wildcard owner  
name's parent. For example, the bug caused a query  
with QNAME "example.com" to match a policy RR with  
"\*.example.com" as trigger. [RT #40357]
- 4185. [bug] Fixed an RPZ bug where a policy RR with wildcard  
owner name (trigger) would prevent another policy RR  
with its parent owner name from being  
loaded. For example, the bug caused a policy RR  
with trigger "example.com" to not have any  
effect when a previous policy RR with trigger  
"\*.example.com" existed in that RPZ zone.  
[RT #40357]

(continues on next page)

(continued from previous page)

- 4184. [bug] Fixed a possible memory leak in name compression when rendering long messages. (Also, improved wire\_test for testing such messages.) [RT #40375]
- 4183. [cleanup] Use timing-safe memory comparisons in cryptographic code. Also, the timing-safe comparison functions have been renamed to avoid possible confusion with memcmp(). Thanks to Loganaden Velvindron of AFRINIC. [RT #40148]
- 4182. [cleanup] Use mnemonics for RR class and type comparisons. [RT #40297]
- 4181. [bug] Queued notify messages could be dequeued from the wrong rate limiter queue. [RT #40350]
- 4180. [bug] Error responses in pipelined queries could cause a crash in client.c. [RT #40289]
- 4179. [bug] Fix double frees in getaddrinfo() in libirs. [RT #40209]
- 4178. [bug] Fix assertion failure in parsing UNSPEC(103) RR from text. [RT #40274]
- 4177. [bug] Fix assertion failure in parsing NSAP records from text. [RT #40285]
- 4176. [bug] Address race issues with lwresd. [RT #40284]
- 4175. [bug] TKEY with GSS-API keys needed bigger buffers. [RT #40333]
- 4174. [bug] "dnssec-coverage -r" didn't handle time unit suffixes correctly. [RT #38444]
- 4173. [bug] dig +sigchase was not properly matching the trusted key. [RT #40188]
- 4172. [bug] Named / named-checkconf didn't handle a view of CLASS0. [RT #40265]
- 4171. [bug] Fixed incorrect class checks in TSIG RR implementation. [RT #40287]
- 4170. [security] An incorrect boundary check in the OPENPGPKEY rdatatype could trigger an assertion failure. (CVE-2015-5986) [RT #40286]
- 4169. [test] Added a 'wire\_test -d' option to read input as raw binary data, for use as a fuzzing harness.

(continues on next page)

(continued from previous page)

- [RT #40312]

4168. [security] A buffer accounting error could trigger an assertion failure when parsing certain malformed DNSSEC keys. (CVE-2015-5722) [RT #40212]
- 4167. [func] Update rndc's usage output to include recently added commands. Thanks to Tony Finch for submitting a patch. [RT #40010]
- 4166. [func] Print informative output from rndc showzone when allow-new-zones is not enabled for a view. Thanks to Tony Finch for submitting a patch. [RT #40009]
- 4165. [security] A failure to reset a value to NULL in tkey.c could result in an assertion failure. (CVE-2015-5477) [RT #40046]
- 4164. [bug] Don't rename slave files and journals on out of memory. [RT #40033]
- 4163. [bug] Address compiler warnings. [RT #40024]
- 4162. [bug] httpdmgr->flags was not being initialized. [RT #40017]
- 4161. [test] Add JSON test for traffic size stats; also test for consistency between "rndc stats" and the XML and JSON statistics channel contents. [RT #38700]
- 4160. [placeholder]
- 4159. [cleanup] Alphabetize dig's help output. [RT #39966]
- 4158. [placeholder]
- 4157. [placeholder]
- 4156. [func] Added statistics counters to track the sizes of incoming queries and outgoing responses in histogram buckets, as specified in RSSAC002. [RT #39049]
- 4155. [func] Allow RPZ rewrite logging to be configured on a per-zone basis using a newly introduced log clause in the response-policy option. [RT #39754]
- 4154. [bug] A OPT record should be included with the FORMERR response when there is a malformed EDNS option. [RT #39647]
- 4153. [bug] Dig should zero non significant +subnet bits. Check that non significant ECS bits are zero on receipt.

(continues on next page)

(continued from previous page)

		[RT #39647]
4152.	[func]	Implement DNS COOKIE option. This replaces the experimental SIT option of BIND 9.10. The following named.conf directives are available: send-cookie, cookie-secret, cookie-algorithm, nocookie-udp-size and require-server-cookie. The following dig options are available: +[no]cookie[=value] and +[no]badcookie. [RT #39928]
4151.	[bug]	'rndc flush' could cause a deadlock. [RT #39835]
4150.	[bug]	win32: listen-on-v6 { any; }; was not working. Apply minimal fix. [RT #39667]
4149.	[bug]	Fixed a race condition in the getaddrinfo() implementation in libirs, which caused the delv utility to crash with an assertion failure when using the '@server' syntax with a hostname argument. [RT #39899]
4148.	[bug]	Fix a bug when printing zone names with '/' character in XML and JSON statistics output. [RT #39873]
4147.	[bug]	Filter-aaaa / filter-aaaa-on-v4 / filter-aaaa-on-v6 was returning referrals rather than nodata responses when the AAAA records were filtered. [RT #39843]
4146.	[bug]	Address reference leak that could prevent a clean shutdown. [RT #37125]
4145.	[bug]	Not all unassociated adb entries were being printed. [RT #37125]
4144.	[func]	Add statistics counters for nxdomain redirections. [RT #39790]
4143.	[placeholder]	
4142.	[bug]	rndc addzone with view specified saved NZF config that could not be read back by named. This has now been fixed. [RT #39845]
4141.	[bug]	A formatting bug caused rndc zonestatus to print negative numbers for large serial values. This has now been fixed. [RT #39854]
4140.	[cleanup]	Remove redundant nzf_remove() call during delzone. [RT #39844]
4139.	[doc]	Fix rpz-client-ip documentation. [RT #39783]

(continues on next page)

(continued from previous page)

4138.	[security]	An uninitialized value in validator.c could result in an assertion failure. (CVE-2015-4620) [RT #39795]
4137.	[bug]	Make rndc reconfig report configuration errors the same way rndc reload does. [RT #39635]
4136.	[bug]	Stale statistics counters with the leading '#' prefix (such as #NXDOMAIN) were not being updated correctly. This has been fixed. [RT #39141]
4135.	[cleanup]	Log expired NTA at startup. [RT #39680]
4134.	[cleanup]	Include client-ip rules when logging the number of RPZ rules of each type. [RT #39670]
4133.	[port]	Update how various json libraries are handled. [RT #39646]
4132.	[cleanup]	dig: added +rd as a synonym for +recurse, added +class as an unabbreviated alternative to +cl. [RT #39686]
4131.	[bug]	Addressed further problems with reloading RPZ zones. [RT #39649]
4130.	[bug]	The compatibility shim for *printf() misprinted some large numbers. [RT #39586]
4129.	[port]	Address API changes in OpenSSL 1.1.0. [RT #39532]
4128.	[bug]	Address issues raised by Coverity 7.6. [RT #39537]
4127.	[protocol]	CDS and CDNSKEY need to be signed by the key signing key as per RFC 7344, Section 4.1. [RT #37215]
4126.	[bug]	Addressed a regression introduced in change #4121. [RT #39611]
4125.	[test]	Added tests for dig, renamed delv test to digdelv. [RT #39490]
4124.	[func]	Log errors or warnings encountered when parsing the internal default configuration. Clarify the logging of errors and warnings encountered in rndc addzone or modzone parameters. [RT #39440]
4123.	[port]	Added %z (size_t) format options to the portable internal printf/sprintf implementation. [RT #39586]
4122.	[bug]	The server could match a shorter prefix than what was available in CLIENT-IP policy triggers, and so, an unexpected action could be taken. This has been

(continues on next page)

(continued from previous page)

		corrected. [RT #39481]
4121.	[bug]	On servers with one or more policy zones configured as slaves, if a policy zone updated during regular operation (rather than at startup) using a full zone reload, such as via AXFR, a bug could allow the RPZ summary data to fall out of sync, potentially leading to an assertion failure in rpz.c when further incremental updates were made to the zone, such as via IXFR. [RT #39567]
4120.	[bug]	A bug in RPZ could cause the server to crash if policy zones were updated while recursion was pending for RPZ processing of an active query. [RT #39415]
4119.	[test]	Allow dig to set the message opcode. [RT #39550]
4118.	[bug]	Teach isc-config.sh about irs. [RT #39213]
4117.	[protocol]	Add EMPTY.AS112.ARPA as per RFC 7534.
4116.	[bug]	Fix a bug in RPZ that could cause some policy zones that did not specifically require recursion to be treated as if they did; consequently, setting qname-wait-recurse no; was sometimes ineffective. [RT #39229]
4115.	[func]	"rndc -r" now prints the result code (e.g., ISC_R_SUCCESS, ISC_R_TIMEOUT, etc) after running the requested command. [RT #38913]
4114.	[bug]	Fix a regression in radix tree implementation introduced by ECS code. This bug was never released, but it was reported by a user testing master. [RT #38983]
4113.	[test]	Check for Net::DNS is some system test prerequisites. [RT #39369]
4112.	[bug]	Named failed to load when "root-delegation-only" was used without a list of domains to exclude. [RT #39380]
4111.	[doc]	Alphabetize rndc man page. [RT #39360]
4110.	[bug]	Address memory leaks / null pointer dereferences on out of memory. [RT #39310]
4109.	[port]	linux: support reading the local port range from net.ipv4.ip_local_port_range. [RT # 39379]

(continues on next page)

(continued from previous page)

- 4108. [func] An additional NXDOMAIN redirect method (option "nxdomain-redirect") has been added, allowing redirection to a specified DNS namespace instead of a single redirect zone. [RT #37989]
- 4107. [bug] Address potential deadlock when updating zone content. [RT #39269]
- 4106. [port] Improve readline support. [RT #38938]
- 4105. [port] Misc fixes for Microsoft Visual Studio 2015 CTP6 in 64 bit mode. [RT #39308]
- 4104. [bug] Address uninitialized elements. [RT #39252]
- 4103. [port] Misc fixes for Microsoft Visual Studio 2015 CTP6. [RT #39267]
- 4102. [bug] Fix a use after free bug introduced in change #4094. [RT #39281]
- 4101. [bug] dig: the +split and +rrcomments options didn't work with +short. [RT #39291]
- 4100. [bug] Inherited ovrnames on the line immediately following a \$INCLUDE were not working. [RT #39268]
- 4099. [port] clang: make unknown commandline options hard errors when determining what options are supported. [RT #39273]
- 4098. [bug] Address use-after-free issue when using a predecessor key with dnssec-settime. [RT #39272]
- 4097. [func] Add additional logging about xfrin transfer status. [RT #39170]
- 4096. [bug] Fix a use after free of query->sendevent. [RT #39132]
- 4095. [bug] zone->options2 was not being properly initialized. [RT #39228]
- 4094. [bug] A race during shutdown or reconfiguration could cause an assertion in mem.c. [RT #38979]
- 4093. [func] Dig now learns the SIT value from truncated responses when it retries over TCP. [RT #39047]
- 4092. [bug] 'in-view' didn't work for zones beneath a empty zone. [RT #39173]

(continues on next page)

(continued from previous page)

- 4091. [cleanup] Some cleanups in isc mem code. [RT #38896]
- 4090. [bug] Fix a crash while parsing malformed CAA RRs in presentation format, i.e., from text such as from master files. Thanks to John Van de Meulebrouck Brendgard for discovering and reporting this problem. [RT #39003]
- 4089. [bug] Send notifies immediately for slave zones during startup. [RT #38843]
- 4088. [port] Fixed errors when building with libressl. [RT #38899]
- 4087. [bug] Fix a crash due to use-after-free due to sequencing of tasks actions. [RT #38495]
- 4086. [bug] Fix out-of-srcdir build with native pkcs11. [RT #38831]
- 4085. [bug] ISC\_PLATFORM\_HAVEXADDQ could be inconsistently set. [RT #38828]
- 4084. [bug] Fix a possible race in updating stats counters. [RT #38826]
- 4083. [cleanup] Print the number of CPUs and UDP listeners consistently in the log and in "rndc status" output; indicate whether threads are supported in "named -V" output. [RT #38811]
- 4082. [bug] Incrementally sign large inline zone deltas. [RT #37927]
- 4081. [cleanup] Use dns\_rdatalist\_init consistently. [RT #38759]
- 4080. [func] Completed change #4022, adding a "lock-file" option to named.conf to override the default lock file, in addition to the "named -X <filename>" command line option. Setting the lock file to "none" using either method disables the check completely. [RT #37908]
- 4079. [func] Preserve the case of the owner name of records to the RRset level. [RT #37442]
- 4078. [bug] Handle the case where CMSG\_SPACE(sizeof(int)) != CMSG\_SPACE(sizeof(char)). [RT #38621]
- 4077. [test] Add static-stub regression test for DS NXDOMAIN return making the static stub disappear. [RT #38564]
- 4076. [bug] Named could crash on shutdown with outstanding

(continues on next page)

(continued from previous page)

		reload / reconfig events. [RT #38622]
4075.	[placeholder]	
4074.	[cleanup]	Cleaned up more warnings from gcc -Wshadow. [RT #38708]
4073.	[cleanup]	Add libjson-c version number reporting to "named -V"; normalize version number formatting. [RT #38056]
4072.	[func]	Add a --enable-querytrace configure switch for very verbose query trace logging. (This option has a negative performance impact and should be used only for debugging.) [RT #37520]
4071.	[cleanup]	Initialize pthread mutex attrs just once, instead of doing it per mutex creation. [RT #38547]
4070.	[bug]	Fix a segfault in nslookup in a query such as "nslookup isc.org AMS.SNS-PB.ISC.ORG -all". [RT #38548]
4069.	[doc]	Reorganize options in the nsupdate man page. [RT #38515]
4068.	[bug]	Omit unknown serial number from JSON zone statistics. [RT #38604]
4067.	[cleanup]	Reduce noise from RRL when query logging is disabled. [RT #38648]
4066.	[doc]	Reorganize options in the dig man page. [RT #38516]
4065.	[test]	Additional RFC 5011 tests. [RT #38569]
4064.	[contrib]	dnssec-keyset.sh: Generates a specified number of DNSSEC keys with timing set to implement a pre-publication key rollover strategy. Thanks to Jeffry A. Spain. [RT #38459]
4063.	[bug]	Asynchronous zone loads were not handled correctly when the zone load was already in progress; this could trigger a crash in zt.c. [RT #37573]
4062.	[bug]	Fix an out-of-bounds read in RPZ code. If the read succeeded, it doesn't result in a bug during operation. If the read failed, named could segfault. [RT #38559]
4061.	[bug]	Handle timeout in legacy system test. [RT #38573]

(continues on next page)

(continued from previous page)

- 4060. [bug] dns\_rdata\_freestruct could be called on a uninitialized structure when handling a error. [RT #38568]
- 4059. [bug] Addressed valgrind warnings. [RT #38549]
- 4058. [bug] UDP dispatches could use the wrong pseudorandom number generator context. [RT #38578]
- 4057. [bug] 'dnssec-dsfromkey -T 0' failed to add ttl field. [RT #38565]
- 4056. [bug] Expanded automatic testing of trust anchor management and fixed several small bugs including a memory leak and a possible loss of key state information. [RT #38458]
- 4055. [func] "rndc managed-keys" can be used to check status of trust anchors or to force keys to be refreshed, Also, the managed keys data file has easier-to-read comments. [RT #38458]
- 4054. [func] Added a new tool 'mdig', a lightweight clone of dig able to send multiple pipelined queries. [RT #38261]
- 4053. [security] Revoking a managed trust anchor and supplying an untrusted replacement could cause named to crash with an assertion failure. (CVE-2015-1349) [RT #38344]
- 4052. [bug] Fix a leak of query fetchlock. [RT #38454]
- 4051. [bug] Fix a leak of pthread\_mutexattr\_t. [RT #38454]
- 4050. [bug] RPZ could send spurious SERVFAILs in response to duplicate queries. [RT #38510]
- 4049. [bug] CDS and CDNSKEY had the wrong attributes. [RT #38491]
- 4048. [bug] adb hash table was not being grown. [RT #38470]
- 4047. [cleanup] "named -V" now reports the current running versions of OpenSSL and the libxml2 libraries, in addition to the versions that were in use at build time.
- 4046. [bug] Accounting of "total use" in memory context statistics was not correct. [RT #38370]
- 4045. [bug] Skip to next master on dns\_request\_createvia4 failure. [RT #25185]

(continues on next page)

(continued from previous page)

- 4044. [bug] Change 3955 was not complete, resulting in an assertion failure if the timing was just right. [RT #38352]
- 4043. [func] "rndc modzone" can be used to modify the configuration of an existing zone, using similar syntax to "rndc addzone". [RT #37895]
- 4042. [bug] zone.c:iszonesecure was being called too late. [RT #38371]
- 4041. [func] TCP sockets can now be shared while connecting. (This will be used to enable client-side support of pipelined queries.) [RT #38231]
- 4040. [func] Added server-side support for pipelined TCP queries. Clients may continue sending queries via TCP while previous queries are being processed in parallel. (The new "keep-response-order" option allows clients to be specified for which the old behavior will still be used.) [RT #37821]
- 4039. [cleanup] Cleaned up warnings from gcc -Wshadow. [RT #37381]
- 4038. [bug] Add 'rpz' flag to node and use it to determine whether to call dns\_rpz\_delete. This should prevent unbalanced add / delete calls. [RT #36888]
- 4037. [bug] also-notify was ignoring the tsig key when checking for duplicates resulting in some expected notify messages not being sent. [RT #38369]
- 4036. [bug] Make call to open a temporary file name safe during NZF creation. [RT #38331]
- 4035. [bug] Close temporary and NZF FILE pointers before moving the former into the latter's place, as required on Windows. [RT #38332]
- 4034. [func] When added, negative trust anchors (NTA) are now saved to files (viewname.nta), in order to persist across restarts of the named server. [RT #37087]
- 4033. [bug] Missing out of memory check in request.c:req\_send. [RT #38311]
- 4032. [bug] Built-in "empty" zones did not correctly inherit the "allow-transfer" ACL from the options or view. [RT #38310]
- 4031. [bug] named-checkconf -z failed to report a missing file with a hint zone. [RT #38294]

(continues on next page)

(continued from previous page)

- 4030. [func] "rndc delzone" is now applicable to zones that were configured in named.conf, as well as zones that were added via "rndc addzone". (Note, however, that if named.conf is not also modified, the deleted zone will return when named is reloaded.) [RT #37887]
- 4029. [func] "rndc showzone" displays the current configuration of a specified zone. [RT #37887]
- 4028. [bug] \$GENERATE with a zero step was not being caught as a error. A \$GENERATE with a / but no step was not being caught as a error. [RT #38262]
- 4027. [port] Net::DNS 0.81 compatibility. [RT #38165]
- 4026. [bug] Fix RFC 3658 reference in dig +sigchase. [RT #38173]
- 4025. [port] bsdi: failed to build. [RT #38047]
- 4024. [bug] dns\_rdata\_opt\_first, dns\_rdata\_opt\_next, dns\_rdata\_opt\_current, dns\_rdata\_txt\_first, dns\_rdata\_txt\_next and dns\_rdata\_txt\_current were documented but not implemented. These have now been implemented.  
  
dns\_rdata\_spf\_first, dns\_rdata\_spf\_next and dns\_rdata\_spf\_current were documented but not implemented. The prototypes for these functions have been removed. [RT #38068]
- 4023. [bug] win32: socket handling with explicit ports and invoking named with -4 was broken for some configurations. [RT #38068]
- 4022. [func] Stop multiple spawns of named by limiting number of processes to 1. This is done by using a lockfile and checking whether we can listen on any configured TCP interfaces. [RT #37908]
- 4021. [bug] Adjust max-recursion-queries to accommodate the need for more queries when the cache is empty. [RT #38104]
- 4020. [bug] Change 3736 broke nsupdate's SOA MNAME discovery resulting in updates being sent to the wrong server. [RT #37925]
- 4019. [func] If named is not configured to validate the answer then allow fallback to plain DNS on timeout even when we know the server supports EDNS. [RT #37978]

(continues on next page)

(continued from previous page)

- 4018. [placeholder]
- 4017. [test] Add system test to check lookups to legacy servers with broken DNS behavior. [RT #37965]
- 4016. [bug] Fix a dig segfault due to bad linked list usage. [RT #37591]
- 4015. [bug] Nameservers that are skipped due to them being CNAMEs were not being logged. They are now logged to category 'cname' as per BIND 8. [RT #37935]
- 4014. [bug] When including a master file origin\_changed was not being properly set leading to a potentially spurious 'inherited owner' warning. [RT #37919]
- 4013. [func] Add a new tcp-only option to server (config) / peer (struct) to use TCP transport to send queries (in place of UDP transport with a TCP fallback on truncated (TC set) response). [RT #37800]
- 4012. [cleanup] Check returned status of OpenSSL digest and HMAC functions when they return one. Note this applies only to FIPS capable OpenSSL libraries put in FIPS mode and MD5. [RT #37944]
- 4011. [bug] master's list port and dscp inheritance was not properly implemented. [RT #37792]
- 4010. [cleanup] Clear the prefetchable state when initiating a prefetch. [RT #37399]
- 4009. [func] delv: added a +tcp option. [RT #37855]
- 4008. [contrib] Updated zkt to latest version (1.1.3). [RT #37886]
- 4007. [doc] Remove acl forward reference restriction. [RT #37772]
- 4006. [security] A flaw in delegation handling could be exploited to put named into an infinite loop. This has been addressed by placing limits on the number of levels of recursion named will allow (default 7), and the number of iterative queries that it will send (default 50) before terminating a recursive query (CVE-2014-8500).  
  
The recursion depth limit is configured via the "max-recursion-depth" option, and the query limit via the "max-recursion-queries" option. [RT #37580]
- 4005. [func] The buffer used for returning text from rndc

(continues on next page)

(continued from previous page)

		commands is now dynamically resizable, allowing arbitrarily large amounts of text to be sent back to the client. (Prior to this change, it was possible for the output of "rndc tsig-list" to be truncated.) [RT #37731]
4004.	[bug]	When delegations had AAAA glue but not A, a reference could be leaked causing an assertion failure on shutdown. [RT #37796]
4003.	[security]	When geoip-directory was reconfigured during named run-time, the previously loaded GeoIP data could remain, potentially causing wrong ACLs to be used or wrong results to be served based on geolocation (CVE-2014-8680). [RT #37720]
4002.	[security]	Lookups in GeoIP databases that were not loaded could cause an assertion failure (CVE-2014-8680). [RT #37679]
4001.	[security]	The caching of GeoIP lookups did not always handle address families correctly, potentially resulting in an assertion failure (CVE-2014-8680). [RT #37672]
4000.	[bug]	NXDOMAIN redirection incorrectly handled NXRRSET from the redirect zone. [RT #37722]

3999.	[func]	"mkeys" and "nzf" files are now named after their corresponding views, unless the view name contains characters that would be incompatible with use in a filename (i.e., slash, backslash, or capital letters). If a view name does contain these characters, the files will still be named using a cryptographic hash of the view name. Regardless of this, if a file using the old name format is found to exist, it will continue to be used. [RT #37704]
3998.	[bug]	isc_radix_search was returning matches that were too precise. [RT #37680]
3997.	[protocol]	Add OPENPGKEY record. [RT# 37671]
3996.	[bug]	Address use after free on out of memory error in keyring_add. [RT #37639]
3995.	[bug]	receive_secure_serial holds the zone lock for too long. [RT #37626]
3994.	[func]	Dig now supports setting the last unassigned DNS header flag bit (dig +zflag). [RT #37421]

(continues on next page)

(continued from previous page)

- 3993. [func] Dig now supports EDNS negotiation by default.  
(dig +[no]ednsnegotiation).  
  
Note: This is disabled by default in BIND 9.10  
and enabled by default in BIND 9.11. [RT #37604]
- 3992. [func] DiG can now send queries without questions  
(dig +header-only). [RT #37599]
- 3991. [func] Add the ability to buffer logging output by specifying  
"buffered yes;" when defining a channel. [RT #26561]
- 3990. [test] Add tests for unknown DNSSEC algorithm handling.  
[RT #37541]
- 3989. [cleanup] Remove redundant dns\_db\_resigned calls. [RT #35748]
- 3988. [func] Allow the zone serial of a dynamically updatable  
zone to be updated via "rndc signing -serial".  
[RT #37404]
- 3987. [port] Handle future Visual Studio 14 incompatible changes.  
[RT #37380]
- 3986. [doc] Add the BIND version number to page footers  
in the ARM. [RT #37398]
- 3985. [doc] Describe how +ndots and +search interact in dig.  
[RT #37529]
- 3984. [func] Accept 256 byte long PINs in native PKCS#11  
crypto. [RT #37410]
- 3983. [bug] Change #3940 was incomplete: negative trust anchors  
could be set to last up to a week, but the  
"nta-lifetime" and "nta-recheck" options were  
still limited to one day. [RT #37522]
- 3982. [doc] Include release notes in product documentation.  
[RT #37272]
- 3981. [bug] Cache DS/NXDOMAIN independently of other query types.  
[RT #37467]
- 3980. [bug] Improve --with-tuning=large by self tuning of SO\_RCVBUF  
size. [RT #37187]
- 3979. [bug] Negative trust anchor fetches were not properly  
managed. [RT #37488]
- 3978. [test] Added a unit test for Diffie-Hellman key

(continues on next page)

(continued from previous page)

		computation, completing change #3974. [RT #37477]
3977.	[cleanup]	"rndc secroots" reported a "not found" error when there were no negative trust anchors set. [RT #37506]
3976.	[bug]	When refreshing managed-key trust anchors, clear any cached trust so that they will always be revalidated with the current set of secure roots. [RT #37506]
3975.	[bug]	Don't populate or use the bad cache for queries that don't request or use recursion. [RT #37466]
3974.	[bug]	Handle DH_compute_key() failure correctly in openssldh_link.c. [RT #37477]
3973.	[test]	Added hooks for Google Performance Tools CPU profiler, including real-time/wall-clock profiling. Use "configure --with-gperftools-profiler" to enable. [RT #37339]
3972.	[bug]	Fix host's usage statement. [RT #37397]
3971.	[bug]	Reduce the cascading failures due to a bad \$TTL line in named-checkconf / named-checkzone. [RT #37138]
3970.	[contrib]	Fixed a use after free bug in the SDB LDAP driver. [RT #37237]
3969.	[test]	Added 'delv' system test. [RT #36901]
3968.	[bug]	Silence spurious log messages when using 'named -[46]'. [RT #37308]
3967.	[test]	Add test for inlined signed zone in multiple views with different DNSKEY sets. [RT #35759]
3966.	[bug]	Missing dns_db_closeversion call in receive_secure_db. [RT #35746]
3965.	[func]	Log outgoing packets and improve packet logging to support logging the remote address. [RT #36624]
3964.	[func]	nsupdate now performs check-names processing. [RT #36266]
3963.	[test]	Added NXRRSET test cases to the "dlzexternal" system test. [RT #37344]
3962.	[bug]	'dig +topdown +trace +sigchase' address unhandled error conditions. [RT #34663]

(continues on next page)

(continued from previous page)

- 3961. [bug] Forwarding of SIG(0) signed UPDATE messages failed with BADSIG. [RT #37216]
- 3960. [bug] 'dig +sigchase' could loop forever. [RT #37220]
- 3959. [bug] Updates could be lost if they arrived immediately after a rndc thaw. [RT #37233]
- 3958. [bug] Detect when writeable files have multiple references in named.conf. [RT #37172]
- 3957. [bug] "dnssec-keygen -S" failed for ECCGOST, ECDSAP256SHA256 and ECDSAP384SHA384. [RT #37183]
- 3956. [func] Notify messages are now rate limited by notify-rate and startup-notify-rate instead of serial-query-rate. [RT #24454]
- 3955. [bug] Notify messages due to changes are no longer queued behind startup notify messages. [RT #24454]
- 3954. [bug] Unchecked mutex init in dlz\_dlopen\_driver.c [RT #37112]
- 3953. [bug] Don't escape semi-colon in TXT fields. [RT #37159]
- 3952. [bug] dns\_name\_fullcompare failed to set \*nlabelsp when the two name pointers were the same. [RT #37176]
- 3951. [func] Add the ability to set yet-to-be-defined EDNS flags to dig (+ednsflags=#). [RT #37142]
- 3950. [port] Changed the bin/python Makefile to work around a bmake bug in FreeBSD 10 and NetBSD 6. [RT #36993]
- 3949. [experimental] Experimental support for draft-andrews-edns1 by sending EDNS(1) queries (define DRAFT\_ANDREWS\_EDNS1 when building). Add support for limiting the EDNS version advertised to servers: server { edns-version 0; }; Log the EDNS version received in the query log. [RT #35864]
- 3948. [port] solaris: RCVBUFSIZE was too large on Solaris with --with-tuning=large. [RT #37059]
- 3947. [cleanup] Set the executable bit on libraries when using libtool. [RT #36786]
- 3946. [cleanup] Improved "configure" search for a python interpreter. [RT #36992]
- 3945. [bug] Invalid wildcard expansions could be incorrectly accepted by the validator. [RT #37093]

(continues on next page)

(continued from previous page)

- 3944. [test] Added a regression test for "server-id". [RT #37057]
- 3943. [func] SERVFAIL responses can now be cached for a limited time (configured by "servfail-ttl", default 10 seconds, limit 30). This can reduce the frequency of retries when an authoritative server is known to be failing, e.g., due to ongoing DNSSEC validation problems. [RT #21347]
- 3942. [bug] Wildcard responses from a optout range should be marked as insecure. [RT #37072]
- 3941. [doc] Include the BIND version number in the ARM. [RT #37067]
- 3940. [func] "rndc nta" now allows negative trust anchors to be set for up to one week. [RT #37069]
- 3939. [func] Improve UPDATE forwarding performance by allowing TCP connections to be shared. [RT #37039]
- 3938. [func] Added quotas to be used in recursive resolvers that are under high query load for names in zones whose authoritative servers are nonresponsive or are experiencing a denial of service attack.
  - "fetches-per-server" limits the number of simultaneous queries that can be sent to any single authoritative server. The configured value is a starting point; it is automatically adjusted downward if the server is partially or completely non-responsive. The algorithm used to adjust the quota can be configured via the "fetch-quota-params" option.
  - "fetches-per-zone" limits the number of simultaneous queries that can be sent for names within a single domain. (Note: Unlike "fetches-per-server", this value is not self-tuning.)
  - New stats counters have been added to count queries spilled due to these quotas.

See the ARM for details of these options. [RT #37125]
- 3937. [func] Added some debug logging to better indicate the conditions causing SERVFAILs when resolving. [RT #35538]
- 3936. [func] Added authoritative support for the EDNS Client Subnet (ECS) option.
 

ACLs can now include "ecs" elements which specify

(continues on next page)

(continued from previous page)

an address or network prefix; if an ECS option is included in a DNS query, then the address encoded in the option will be matched against "ecs" ACL elements.

Also, if an ECS address is included in a query, then it will be used instead of the client source address when matching "geoip" ACL elements. This behavior can be overridden with "geoip-use-ecs no;". (Note: to enable "geoip" ACLs, use "configure --with-geoip". This requires libGeoIP version 1.5.0 or higher.)

When "ecs" or "geoip" ACL elements are used to select a view for a query, the response will include an ECS option to indicate which client network the answer is valid for.

(Thanks to Vincent Bernat.) [RT #36781]

- 3935. [bug] "geoip asnum" ACL elements would not match unless the full organization name was specified. They can now match against the AS number alone (e.g., AS1234). [RT #36945]
- 3934. [bug] Catch bad 'sit-secret' in named-checkconf. Improve sit-secret documentation. [RT #36980]
- 3933. [bug] Corrected the implementation of dns\_rdata\_casecompare() for the HIP rdata type. [RT #36911]
- 3932. [test] Improved named-checkconf tests. [RT #36911]
- 3931. [cleanup] Cleanup how dlz grammar is defined. [RT #36879]
- 3930. [bug] "rndc nta -r" could cause a server hang if the NTA was not found. [RT #36909]
- 3929. [bug] 'host -a' needed to clear idnoptions. [RT #36963]
- 3928. [test] Improve rndc system test. [RT #36898]
- 3927. [bug] dig: report PKCS#11 error codes correctly when compiled with --enable-native-pkcs11. [RT #36956]
- 3926. [doc] Added doc for geoip-directory. [RT #36877]
- 3925. [bug] DS lookup of RFC 1918 empty zones failed. [RT #36917]
- 3924. [bug] Improve 'rndc addzone' error reporting. [RT #35187]
- 3923. [bug] Sanity check the xml2-config output. [RT #22246]

(continues on next page)

(continued from previous page)

- 3922. [bug] When resigning, dnssec-signzone was removing all signatures from delegation nodes. It now retains DS and (if applicable) NSEC signatures. [RT #36946]
- 3921. [bug] AD was inappropriately set on RPZ responses. [RT #36833]
- 3920. [doc] Added doc for masterfile-style. [RT #36823]
- 3919. [bug] dig: continue to next line if a address lookup fails in batch mode. [RT #36755]
- 3918. [doc] Update check-spf documentation. [RT #36910]
- 3917. [bug] dig, nslookup and host now continue on names that are too long after applying a search list elements. [RT #36892]
- 3916. [contrib] zone2sqlite checked wrong result code. Address compiler warnings. [RT #36931]
- 3915. [bug] Address a assertion if a route event arrived while shutting down. [RT #36887]
- 3914. [bug] Allow the URI target and CAA value fields to be zero length. [RT #36737]
- 3913. [bug] Address race issue in dispatch. [RT #36731]
- 3912. [bug] Address some unrecoverable lookup failures. [RT #36330]
- 3911. [func] Implement EDNS EXPIRE option client side, allowing a slave server to set the expiration timer correctly when transferring zone data from another slave server. [RT #35925]
- 3910. [bug] Fix races to free event during shutdown. [RT #36720]
- 3909. [bug] When computing the number of elements required for a acl count\_acl\_elements could have a short count leading to a assertion failure. Also zero out new acl elements in dns\_acl\_merge. [RT #36675]
- 3908. [bug] rndc now differentiates between a zone in multiple views and a zone that doesn't exist at all. [RT #36691]
- 3907. [cleanup] Alphabetize rndc help. [RT #36683]
- 3906. [protocol] Update URI record format to comply with draft-faltstrom-uri-08. [RT #36642]

(continues on next page)

(continued from previous page)

- 3905. [bug] Address deadlock between view.c and adb.c. [RT #36341]
- 3904. [func] Add the RPZ SOA to the additional section. [RT36507]
- 3903. [bug] Improve the accuracy of DiG's reported round trip time. [RT 36611]
- 3902. [bug] liblwres wasn't handling link-local addresses in nameserver clauses in resolv.conf. [RT #36039]
- 3901. [protocol] Added support for CAA record type (RFC 6844). [RT #36625]
- 3900. [bug] Fix a crash in PostgreSQL DLZ driver. [RT #36637]
- 3899. [bug] "request-ixfr" is only applicable to slave and redirect zones. [RT #36608]
- 3898. [bug] Too small a buffer in tohexstr() calls in test code. [RT #36598]
- 3897. [bug] RPZ summary information was not properly being updated after a AXFR resulting in changes sometimes being ignored. [RT #35885]
- 3896. [bug] Address performance issues with DSCP code on some platforms. [RT #36534]
- 3895. [func] Add the ability to set the DSCP code point to dig. [RT #36546]
- 3894. [bug] Buffers in isc\_print\_vsnprintf were not properly initialized leading to potential overflows when printing out quad values. [RT #36505]
- 3893. [bug] Peer DSCP values could be returned without being set. [RT #36538]
- 3892. [bug] Setting '-t aaaa' in .digrc had unintended side effects. [RT #36452]
- 3891. [bug] Use \${INSTALL\_SCRIPT} rather than \${INSTALL\_PROGRAM} to install python programs.
- 3890. [bug] RRSIG sets that were not loaded in a single transaction at start up where not being correctly added to re-signing heaps. [RT #36302]
- 3889. [port] hurd: configure fixes as per:  
<https://bugs.debian.org/cgi-bin/bugreport.cgi?bug=746540>
- 3888. [func] 'rndc status' now reports the number of automatic

(continues on next page)

(continued from previous page)

		zones. [RT #36015]
3887.	[cleanup]	Make all static symbols in rbtodb64 end in "64" so they are easier to use in a debugger. [RT #36373]
3886.	[bug]	rbtodb_write_header should use a once to initialize FILE_VERSION. [RT #36374]
3885.	[port]	Use 'open()' rather than 'file()' to open files in python.
3884.	[protocol]	Add CDS and CDNSKEY record types. [RT #36333]
3883.	[placeholder]	
3882.	[func]	By default, negative trust anchors will be tested periodically to see whether data below them can be validated, and if so, they will be allowed to expire early. The "rndc nta -force" option overrides this behavior. The default NTA lifetime and the recheck frequency can be configured by the "nta-lifetime" and "nta-recheck" options. [RT #36146]
3881.	[bug]	Address memory leak with UPDATE error handling. [RT #36303]
3880.	[test]	Update ans.pl to work with new TSIG support in Net::DNS; add additional Net::DNS version prerequisite checks. [RT #36327]
3879.	[func]	Add version printing option to various BIND utilities. [RT #10686]
3878.	[bug]	Using the incorrect filename for a DLZ module caused a segmentation fault on startup. [RT #36286]
3877.	[bug]	Inserting and deleting parent and child nodes in response policy zones could trigger an assertion failure. [RT #36272]
3876.	[bug]	Improve efficiency of DLZ redirect zones by suppressing unnecessary database lookups. [RT #35835]
3875.	[cleanup]	Clarify log message when unable to read private key files. [RT #24702]
3874.	[test]	Check that only "check-names master" is needed for updates to be accepted.
3873.	[protocol]	Only warn for SPF without TXT spf record. [RT #36210]
3872.	[bug]	Address issues found by static analysis. [RT #36209]

(continues on next page)

(continued from previous page)

- 3871. [bug] Don't publish an activated key automatically before its publish time. [RT #35063]
- 3870. [func] Updated the random number generator used in the resolver to use the updated ChaCha based one (similar to OpenBSD's changes). Also moved the RNG to libisc and added unit tests for it. [RT #35942]
- 3869. [doc] Document that in-view zones cannot be used for response policy zones. [RT #35941]
- 3868. [bug] isc\_mem\_setwater incorrectly cleared hi\_called potentially leaving over memory cleaner running. [RT #35270]
- 3867. [func] "rndc nta" can now be used to set a temporary negative trust anchor, which disables DNSSEC validation below a specified name for a specified period of time (not exceeding 24 hours). This can be used when validation for a domain is known to be failing due to a configuration error on the part of the domain owner rather than a spoofing attack. [RT #29358]
- 3866. [bug] Named could die on disk full in generate\_session\_key. [RT #36119]
- 3865. [test] Improved testability of the red-black tree implementation and added unit tests. [RT #35904]
- 3864. [bug] RPZ didn't work well when being used as forwarder. [RT #36060]
- 3863. [bug] The "E" flag was missing from the query log as a unintended side effect of code rearrangement to support EDNS EXPIRE. [RT #36117]
- 3862. [cleanup] Return immediately if we are not going to log the message in ns\_client\_dumpmessage.
- 3861. [security] Missing isc\_buffer\_availablelength check results in a REQUIRE assertion when printing out a packet (CVE-2014-3859). [RT #36078]
- 3860. [bug] ioctl(DP\_POLL) array size needs to be determined at run time as it is limited to {OPEN\_MAX}. [RT #35878]
- 3859. [placeholder]

(continues on next page)

(continued from previous page)

- 3858. [bug] Disable GCC 4.9 "delete null pointer check".  
[RT #35968]
- 3857. [bug] Make it harder for a incorrect NOEDNS classification  
to be made. [RT #36020]
- 3856. [bug] Configuring libjson without also configuring libxml  
resulted in a REQUIRE assertion when retrieving  
statistics using json. [RT #36009]
- 3855. [bug] Limit smoothed round trip time aging to no more than  
once a second. [RT #32909]
- 3854. [cleanup] Report unrecognized options, if any, in the final  
configure summary. [RT #36014]
- 3853. [cleanup] Refactor dns\_rdataslab\_fromrdataset to separate out  
the handling of a rdataset with no records. [RT #35968]
- 3852. [func] Increase the default number of clients available  
for servicing lightweight resolver queries, and  
make them configurable via the "lwres-tasks" and  
"lwres-clients" options. (Thanks to Tomas Hozza.)  
[RT #35857]
- 3851. [func] Allow libseccomp based system-call filtering  
on Linux; use "configure --enable-seccomp" to  
turn it on. Thanks to Loganaden Velvindron  
of AFRINIC for the contribution. [RT #35347]
- 3850. [bug] Disabling forwarding could trigger a REQUIRE assertion.  
[RT #35979]
- 3849. [doc] Alphabetized dig's +options. [RT #35992]
- 3848. [bug] Adjust 'statistics-channels specified but not effective'  
error message to account for JSON support. [RT #36008]
- 3847. [bug] 'configure --with-dlz-postgres' failed to fail when  
there is not support available.
- 3846. [bug] "dig +notcp ixfr=<serial>" should result in a UDP  
ixfr query. [RT #35980]
- 3845. [placeholder]
- 3844. [bug] Use the x64 version of the Microsoft Visual C++  
Redistributable when built for 64 bit Windows.  
[RT #35973]
- 3843. [protocol] Check EDNS EXPIRE option in dns\_rdata\_fromwire.  
[RT #35969]

(continues on next page)

(continued from previous page)

- 3842. [bug] Adjust RRL log-only logging category. [RT #35945]
- 3841. [cleanup] Refactor zone.c:add\_opt to use dns\_message\_buildopt. [RT #35924]
- 3840. [port] Check for arc4random\_addrandom() before using it; it's been removed from OpenBSD 5.5. [RT #35907]
- 3839. [test] Use only posix-compatible shell in system tests. [RT #35625]
- 3838. [protocol] EDNS EXPIRE as been assigned a code point of 9.
- 3837. [security] A NULL pointer is passed to query\_prefetch resulting a REQUIRE assertion failure when a fetch is actually initiated (CVE-2014-3214). [RT #35899]
- 3836. [bug] Address C++ keyword usage in header file.
- 3835. [bug] Geoip ACL elements didn't work correctly when referenced via named or nested ACLs. [RT #35879]
- 3834. [bug] The re-signing heaps were not being updated soon enough leading to multiple re-generations of the same RRSIG when a zone transfer was in progress. [RT #35273]
- 3833. [bug] Cross compiling was broken due to calling genrandom at build time. [RT #35869]
- 3832. [func] "named -L <filename>" causes named to send log messages to the specified file by default instead of to the system log. (Thanks to Tony Finch.) [RT #35845]
- 3831. [cleanup] Reduce logging noise when EDNS state changes occur. [RT #35843]
- 3830. [func] When query logging is enabled, log query errors at the same level ('info') as the queries themselves. [RT #35844]
- 3829. [func] "dig +ttlunits" causes dig to print TTL values with time-unit suffixes: w, d, h, m, s for weeks, days, hours, minutes, and seconds. (Thanks to Tony Finch.) [RT #35823]
- 3828. [func] "dnssec-signzone -N date" updates serial number to the current date in YYYYMMDDNN format. [RT #35800]
- 3827. [placeholder]

(continues on next page)

(continued from previous page)

- 3826. [bug] Corrected bad INSIST logic in `isc_radix_remove()`.  
[RT #35870]
- 3825. [bug] Address sign extension bug in `isc_regex_validate`.  
[RT #35758]
- 3824. [bug] A collision between two flag values could cause problems with cache cleaning when SIT was enabled.  
[RT #35858]
- 3823. [func] Log the rpz cname target when rewriting. [RT #35667]
- 3822. [bug] Log the correct type of static-stub zones when removing them. [RT #35842]
- 3821. [contrib] Added a new "mysqldyn" DLZ module with dynamic update and transaction support. Thanks to Marty Lee for the contribution. [RT #35656]
- 3820. [func] The DLZ API doesn't pass the database version to the `lookup()` function; this can cause DLZ modules that allow dynamic updates to mishandle prerequisite checks. This has been corrected by adding a 'dbversion' field to the `dns_clientinfo_t` structure. [RT #35656]
- 3819. [bug] NSEC3 hashes need to be able to be entered and displayed without padding. This is not a issue for currently defined algorithms but may be for future hash algorithms. [RT #27925]
- 3818. [bug] Stop lying to the optimizer that 'void \*arg' is a constant in `isc_event_allocate`.
- 3817. [func] The "delve" command is now spelled "delv" to avoid a namespace collision with the Xapian project.  
[RT #35801]
- 3816. [func] "dig +qr" now reports query size. (Thanks to Tony Finch.) [RT #35822]
- 3815. [doc] Clarify "nsupdate -y" usage in man page. [RT #35808]
- 3814. [func] The "masterfile-style" zone option controls the formatting of dumped zone files. Options are "relative" (multiline format) and "full" (one record per line). The default is "relative".  
[RT #20798]
- 3813. [func] "host" now recognizes the "timeout", "attempts" and "debug" options when set in `/etc/resolv.conf`.

(continues on next page)

(continued from previous page)

		(Thanks to Adam Tkac at RedHat.) [RT #21885]
3812.	[func]	Dig now supports sending arbitrary EDNS options from the command line (+ednsopt=code[:value]). [RT #35584]
3811.	[func]	"serial-update-method date;" sets serial number on dynamic update to today's date in YYYYMMDDNN format. (Thanks to Bradley Forschinger.) [RT #24903]
3810.	[bug]	Work around broken nameservers that fail to ignore unknown EDNS options. [RT #35766]
3809.	[doc]	Fix SIT and NSID documentation.
3808.	[doc]	Clean up "prefetch" documentation. [RT #35751]
3807.	[bug]	Fix sign extension bug in dns_name_fromtext when lowercase is set. [RT #35743]
3806.	[test]	Improved system test portability. [RT #35625]
3805.	[contrib]	Added contrib/perftcpdns, a performance testing tool for DNS over TCP. [RT #35710]

		--- 9.10.0rc1 released ---
3804.	[bug]	Corrected a race condition in dispatch.c in which portentry could be reset leading to an assertion failure in socket_search(). (Change #3708 addressed the same issue but was incomplete.) [RT #35128]
3803.	[bug]	"named-checkconf -z" incorrectly rejected zones using alternate data sources for not having a "file" option. [RT #35685]
3802.	[bug]	Various header files were not being installed.
3801.	[port]	Fix probing for gssapi support on FreeBSD. [RT #35615]
3800.	[bug]	A pending event on the route socket could cause an assertion failure when shutting down named. [RT #35674]
3799.	[bug]	Improve named's command line error reporting. [RT #35603]
3798.	[bug]	'rndc zonestatus' was reporting the wrong re-signing time. [RT #35659]
3797.	[port]	netbsd: geoip support probing was broken. [RT #35642]
3796.	[bug]	Register dns and pkcs#11 error codes. [RT #35629]

(continues on next page)

(continued from previous page)

- 3795. [bug] Make named-checkconf detect raw masterfiles for hint zones and reject them. [RT #35268]
- 3794. [maint] Added AAAA for C.ROOT-SERVERS.NET.
- 3793. [bug] zone.c:save\_nsec3param() could assert when out of memory. [RT #35621]
- 3792. [func] Provide links to the alternate statistics views when displaying in a browser. [RT #35605]
- 3791. [placeholder]
- 3790. [bug] Handle broken nameservers that send BADVERS in response to unknown EDNS options. Maintain statistics on BADVERS responses.
- 3789. [bug] Null pointer dereference on rbt creation failure.
- 3788. [bug] dns\_peer\_getrequestsit was returning request\_nsid by mistake.

--- 9.10.0b2 released ---

- 3787. [bug] The code that checks whether "auto-dnssec" is allowed was ignoring "allow-update" ACLs set at the options or view level. [RT #29536]
- 3786. [func] Provide more detailed error codes when using native PKCS#11. "pkcs11-tokens" now fails robustly rather than asserting when run against an HSM with an incomplete PKCS#11 API implementation. [RT #35479]
- 3785. [bug] Debugging code dumphex didn't accept arbitrarily long input (only compiled with -DDEBUG). [RT #35544]
- 3784. [bug] Using "rrset-order fixed" when it had not been enabled at compile time caused inconsistent results. It now works as documented, defaulting to cyclic mode. [RT #28104]
- 3783. [func] "tsig-keygen" is now available as an alternate command name for "ddns-confgen". It generates a TSIG key in named.conf format without comments. [RT #35503]
- 3782. [func] Specifying "auto" as the salt when using "rndc signing -nsec3param" causes named to generate a 64-bit salt at random. [RT #35322]
- 3781. [tuning] Use adaptive mutex locks when available; this

(continues on next page)

(continued from previous page)

		has been found to improve performance under load on many systems. "configure --with-locktype=standard" restores conventional mutex locks. [RT #32576]
3780.	[bug]	\$GENERATE handled negative numbers incorrectly. [RT #25528]
3779.	[cleanup]	Clarify the error message when using an option that was not enabled at compile time. [RT #35504]
3778.	[bug]	Log a warning when the wrong address family is used in "listen-on" or "listen-on-v6". [RT #17848]
3777.	[bug]	EDNS EXPIRE code could dump core when processing DLZ queries. [RT #35493]
3776.	[func]	"rndc -q" suppresses output from successful rndc commands. Errors are printed on stderr. [RT #21393]
3775.	[bug]	dlz_dlopen driver could return the wrong error code on API version mismatch, leading to a segfault. [RT #35495]
3774.	[func]	When using "request-nsid", log the NSID value in printable form as well as hex. [RT #20864]
3773.	[func]	"host", "nslookup" and "nsupdate" now have options to print the version number and exit. [RT #26057]
3772.	[contrib]	Added sqlite3 dynamically-loadable DLZ module. (Based in part on a contribution from Tim Tessier.) [RT #20822]
3771.	[cleanup]	Adjusted log level for "using built-in key" messages. [RT #24383]
3770.	[bug]	"dig +trace" could fail with an assertion when it needed to fall back to TCP due to a truncated response. [RT #24660]
3769.	[doc]	Improved documentation of "rndc signing -list". [RT #30652]
3768.	[bug]	"dnssec-checkds" was missing the SHA-384 digest algorithm. [RT #34000]
3767.	[func]	Log explicitly when using rndc.key to configure command channel. [RT #35316]
3766.	[cleanup]	Fixed problems with building outside the source

(continues on next page)

(continued from previous page)

		tree when using native PKCS#11. [RT #35459]
3765.	[bug]	Fixed a bug in "rndc secroots" that could crash named when dumping an empty keynode. [RT #35469]
3764.	[bug]	The dnssec-keygen/settime -S and -i options (to set up a successor key and set the prepublication interval) were missing from dnssec-keyfromlabel. [RT #35394]
3763.	[bug]	delve: Cache DNSSEC records to avoid the need to re-fetch them when restarting validation. [RT #35476]
3762.	[bug]	Address build problems with --pkcs11-native + --with-openssl with ECDSA support. [RT #35467]
3761.	[bug]	Address dangling reference bug in dns_keytable_add. [RT #35471]
3760.	[bug]	Improve SIT with native PKCS#11 and on Windows. [RT #35433]
3759.	[port]	Enable delve on Windows. [RT #35441]
3758.	[port]	Enable export library APIs on Windows. [RT #35382]
3757.	[port]	Enable Python tools (dnssec-coverage, dnssec-checkds) to run on Windows. [RT #34355]
3756.	[bug]	GSSAPI Kerberos realm checking was broken in check_config leading to spurious messages being logged. [RT #35443]

		--- 9.10.0b1 released ---
3755.	[func]	Add stats counters for known EDNS options + others. [RT #35447]
3754.	[cleanup]	win32: Installer now places files in the Program Files area rather than system services. [RT #35361]
3753.	[bug]	allow-notify was ignoring keys. [RT #35425]
3752.	[bug]	Address potential REQUIRE failure if DNS_STYLEFLAG_COMMENTDATA is set when printing out a rdataset.
3751.	[tuning]	The default setting for the -U option (setting the number of UDP listeners per interface) has been adjusted to improve performance. [RT #35417]

(continues on next page)

(continued from previous page)

- 3750. [experimental] Partially implement EDNS EXPIRE option as described in draft-andrews-dnsext-expire-00. Retrieval of the remaining time until expiry for slave zones is supported.  
  
EXPIRE uses an experimental option code (65002), which is subject to change. [RT #35416]
- 3749. [func] "dig +subnet" sends an EDNS client subnet option containing the specified address/prefix when querying. (Thanks to Wilmer van der Gaast.) [RT #35415]
- 3748. [test] Use delve to test dns\_client interfaces. [RT #35383]
- 3747. [bug] A race condition could lead to a core dump when destroying a resolver fetch object. [RT #35385]
- 3746. [func] New "max-zone-ttl" option enforces maximum TTLs for zones. If loading a zone containing a higher TTL, the load fails. DDNS updates with higher TTLs are accepted but the TTL is truncated. (Note: Currently supported for master zones only; inline-signing slaves will be added.) [RT #38405]
- 3745. [func] "configure --with-tuning=large" adjusts various compiled-in constants and default settings to values suited to large servers with abundant memory. [RT #29538]
- 3744. [experimental] SIT: send and process Source Identity Tokens (similar to DNS Cookies by Donald Eastlake 3rd), which are designed to help clients detect off-path spoofed responses and for servers to identify legitimate clients.  
  
SIT uses an experimental EDNS option code (65001), which will be changed to an IANA-assigned value if the experiment is deemed a success.  
  
SIT can be enabled via "configure --enable-sit" (or --enable-developer). It is enabled by default in Windows.  
  
Servers can be configured to send smaller responses to clients that have not identified themselves via SIT. RRL processing has also been updated; legitimate clients are not subject to rate limiting. [RT #35389]
- 3743. [bug] delegation-only flag wasn't working in forward zone declarations despite being documented. This is

(continues on next page)

(continued from previous page)

		needed to support turning off forwarding and turning on delegation only at the same name. [RT #35392]
3742.	[port]	linux: libcap support: declare curval at start of block. [RT #35387]
3741.	[func]	"delve" (domain entity lookup and validation engine): A new tool with dig-like semantics for performing DNS lookups, with internal DNSSEC validation, using the same resolver and validator logic as named. This allows easy validation of DNSSEC data in environments with untrustworthy resolvers, and assists with troubleshooting of DNSSEC problems. [RT #32406]
3740.	[contrib]	Minor fixes to configure --with-dlz-bdb, --with-dlz-postgres and --with-dlz-odbc. [RT #35340]
3739.	[func]	Added per-zone stats counters to track TCP and UDP queries. [RT #35375]
3738.	[bug]	--enable-openssl-hash failed to build. [RT #35343]
3737.	[bug]	'rndc retransfer' could trigger a assertion failure with inline zones. [RT #35353]
3736.	[bug]	nsupdate: When specifying a server by name, fall back to alternate addresses if the first address for that name is not reachable. [RT #25784]
3735.	[cleanup]	Merged the libiscpk11 library into libisc to simplify dependencies. [RT #35205]
3734.	[bug]	Improve building with libtool. [RT #35314]
3733.	[func]	Improve interface scanning support. Interface information will be automatically updated if the OS supports routing sockets (MacOS, *BSD, Linux). Use "automatic-interface-scan no;" to disable.  Add "rndc scan" to trigger a scan. [RT #23027]
3732.	[contrib]	Fixed a type mismatch causing the ODBC DLZ driver to dump core on 64-bit systems. [RT #35324]
3731.	[func]	Added a "no-case-compress" ACL, which causes named to use case-insensitive compression (disabling change #3645) for specified clients. (This is useful when dealing with broken client implementations that use case-sensitive name comparisons, rejecting responses that fail to match the capitalization of the query that was sent.)

(continues on next page)

(continued from previous page)

		[RT #35300]
3730.	[cleanup]	Added "never" as a synonym for "none" when configuring key event dates in the dnssec tools. [RT #35277]
3729.	[bug]	dnssec-keygen could set the publication date incorrectly when only the activation date was specified on the command line. [RT #35278]
3728.	[doc]	Expanded native-PKCS#11 documentation, specifically pkcs11: URI labels. [RT #35287]
3727.	[func]	The isc_bitstring API is no longer used and has been removed from libisc. [RT #35284]
3726.	[cleanup]	Clarified the error message when attempting to configure more than 32 response-policy zones. [RT #35283]
3725.	[contrib]	Updated zkt and nslint to newest versions, cleaned up and rearranged the contrib directory, and added a README.

		--- 9.10.0a2 released ---
3724.	[bug]	win32: Fixed a bug that prevented dig and host from exiting properly after completing a UDP query. [RT #35288]
3723.	[cleanup]	Imported keys are now handled the same way regardless of DNSSEC algorithm. [RT #35215]
3722.	[bug]	Using geoip ACLs in a blackhole statement could cause a segfault. [RT #35272]
3721.	[doc]	Improved documentation of the EDNS processing enhancements introduced in change #3593. [RT #35275]
3720.	[bug]	Address compiler warnings. [RT #35261]
3719.	[bug]	Address memory leak in in peer.c. [RT #35255]
3718.	[bug]	A missing ISC_LINK_INIT in log.c. [RT #35260]
3717.	[port]	hpux: Treat EOPNOTSUPP as a expected error code when probing to see if it is possible to set dscp values on a per packet basis. [RT #35252]
3716.	[bug]	The dns_request code was setting dscp values when not requested. [RT #35252]

(continues on next page)

(continued from previous page)

- 3715. [bug] The region and city databases could fail to initialize when using some versions of libGeoIP, causing assertion failures when named was configured to use them. [RT #35427]
- 3714. [test] System tests that need to test for cryptography support before running can now use a common "testcrypto.sh" script to do so. [RT #35213]
- 3713. [bug] Save memory by not storing "also-notify" addresses in zone objects that are configured not to send notify requests. [RT #35195]
- 3712. [placeholder]
- 3711. [placeholder]
- 3710. [bug] Address double dns\_zone\_detach when switching to using automatic empty zones from regular zones. [RT #35177]
- 3709. [port] Use built-in versions of strtptime() and timegm() on all platforms to avoid portability issues. [RT #35183]
- 3708. [bug] Address a portentry locking issue in dispatch.c. [RT #35128]
- 3707. [bug] irs\_resconf\_load now returns ISC\_R\_FILENOTFOUND on a missing resolv.conf file and initializes the structure as if it had been configured with:
 

```
nameserver ::1
nameserver 127.0.0.1
```

Note: Callers will need to be updated to treat ISC\_R\_FILENOTFOUND as a qualified success or else they will leak memory. The following code fragment will work with both old and new versions without changing the behaviour of the existing code.

```
resconf = NULL;
result = irs_resconf_load(mctx, "/etc/resolv.conf",
                        &resconf);
if (result != ISC_SUCCESS) {
    if (resconf != NULL)
        irs_resconf_destroy(&resconf);
    ....
}
```

[RT #35194]

(continues on next page)

(continued from previous page)

- 3706. [contrib] queryperf: Fixed a possible integer overflow when printing results. [RT #35182]
- 3705. [func] "configure --enable-native-pkcs11" enables BIND to use the PKCS#11 API for all cryptographic functions, so that it can drive a hardware service module directly without the need to use a modified OpenSSL as intermediary (so long as the HSM's vendor provides a complete-enough implementation of the PKCS#11 interface). This has been tested successfully with the Thales nShield HSM and with SoftHSMv2 from the OpenDNSSEC project. [RT #29031]
- 3704. [protocol] Accept integer timestamps in RRSIG records. [RT #35185]
- 3703. [func] To improve recursive resolver performance, cache records which are still being requested by clients can now be automatically refreshed from the authoritative server before they expire, reducing or eliminating the time window in which no answer is available in the cache. See the "prefetch" option for more details. [RT #35041]
- 3702. [func] 'dnssec-coverage -l' option specifies a length of time to check for coverage; events further into the future are ignored. 'dnssec-coverage -z' checks only ZSK events, and 'dnssec-coverage -k' checks only KSK events. (Thanks to Peter Palfrader.) [RT #35168]
- 3701. [func] named-checkconf can now obscure shared secrets when printing by specifying '-x'. [RT #34465]
- 3700. [func] Allow access to subgroups of XML statistics via special URLs `http://<server>:<port>/xml/v3/server, /zones, /net, /tasks, /mem, and /status.` [RT #35115]
- 3699. [bug] Improvements to statistics channel XSL stylesheet: the stylesheet can now be cached by the browser; section headers are omitted from the stats display when there is no data in those sections to be displayed; counters are now right-justified for easier readability. [RT #35117]
- 3698. [cleanup] Replaced all uses of `memcpy()` with `memmove()`. [RT #35120]
- 3697. [bug] Handle "." as a search list element when IDN support is enabled. [RT #35133]
- 3696. [bug] dig failed to handle AXFR style IXFR responses which span multiple messages. [RT #35137]

(continues on next page)

(continued from previous page)

- 3695. [bug] Address a possible race in dispatch.c. [RT #35107]
- 3694. [bug] Warn when a key-directory is configured for a zone, but does not exist or is not a directory. [RT #35108]
- 3693. [security] memcpy was incorrectly called with overlapping ranges resulting in malformed names being generated on some platforms. This could cause INSIST failures when serving NSEC3 signed zones (CVE-2014-0591). [RT #35120]
- 3692. [bug] Two calls to dns\_db\_getoriginnode were fatal if there was no data at the node. [RT #35080]
- 3691. [contrib] Address null pointer dereference in LDAP and MySQL DLZ modules.
- 3690. [bug] Iterative responses could be missed when the source port for an upstream query was the same as the listener port (53). [RT #34925]
- 3689. [bug] Fixed a bug causing an insecure delegation from one static-stub zone to another to fail with a broken trust chain. [RT #35081]
- 3688. [bug] loadnode could return a freed node on out of memory. [RT #35106]
- 3687. [bug] Address null pointer dereference in zone\_xfrdone. [RT #35042]
- 3686. [func] "dnssec-signzone -Q" drops signatures from keys that are still published but no longer active. [RT #34990]
- 3685. [bug] "rndc refresh" didn't work correctly with slave zones using inline-signing. [RT #35105]
- 3684. [bug] The list of included files would grow on reload. [RT 35090]
- 3683. [cleanup] Add a more detailed "not found" message to rndc commands which specify a zone name. [RT #35059]
- 3682. [bug] Correct the behavior of rndc retransfer to allow inline-signing slave zones to retain NSEC3 parameters instead of reverting to NSEC. [RT #34745]
- 3681. [port] Update the Windows build system to support feature selection and WIN64 builds. This is a work in progress. [RT #34160]

(continues on next page)

(continued from previous page)

- 3680. [bug] Ensure buffer space is available in "rndc zonestatus". [RT #35084]
- 3679. [bug] dig could fail to clean up TCP sockets still waiting on connect(). [RT #35074]
- 3678. [port] Update config.guess and config.sub. [RT #35060]
- 3677. [bug] 'nsupdate' leaked memory if 'realm' was used multiple times. [RT #35073]
- 3676. [bug] "named-checkconf -z" now checks zones of type hint and redirect as well as master. [RT #35046]
- 3675. [misc] Provide a place for third parties to add version information for their extensions in the version file by setting the EXTENSIONS variable.

--- 9.10.0a1 released ---

- 3674. [bug] RPZ zeroed ttls if the query type was '\*'. [RT #35026]
- 3673. [func] New "in-view" zone option allows direct sharing of zones between views. [RT #32968]
- 3672. [func] Local address can now be specified when using dns\_client API. [RT #34811]
- 3671. [bug] Don't allow dnssec-importkey overwrite a existing non-imported private key.
- 3670. [bug] Address read after free in server side of lwres\_getrrsetbyname. [RT #29075]
- 3669. [port] freebsd: --with-gssapi needs -lhx509. [RT #35001]
- 3668. [bug] Fix cast in lex.c which could see 0xff treated as eof. [RT #34993]
- 3667. [test] dig: add support to keep the TCP socket open between successive queries (+[no]keepopen). [RT #34918]
- 3666. [func] Add a tool, named-rrchecker, for checking the syntax of individual resource records. This tool is intended to be called by provisioning systems so that the front end does not need to be upgraded to support new DNS record types. [RT #34778]
- 3665. [bug] Failure to release lock on error in receive\_secure\_db. [RT #34944]

(continues on next page)

(continued from previous page)

- 3664. [bug] Updated OpenSSL PKCS#11 patches to fix active list locking and other bugs. [RT #34855]
- 3663. [bug] Address bugs in dns\_rdata\_fromstruct and dns\_rdata\_tostruct for WKS and ISDN types. [RT #34910]
- 3662. [bug] 'host' could die if a UDP query timed out. [RT #34870]
- 3661. [bug] Address lock order reversal deadlock with inline zones. [RT #34856]
- 3660. [cleanup] Changed the name of "isc-config.sh" to "bind9-config". [RT #23825]
- 3659. [port] solaris: don't add explicit dependencies/rules for python programs as make won't use the implicit rules. [RT #34835]
- 3658. [port] linux: Address platform specific compilation issue when libcap-devel is installed. [RT #34838]
- 3657. [port] Some readline clones don't accept NULL pointers when calling add\_history. [RT #34842]
- 3656. [security] Treat an all zero netmask as invalid when generating the localnets acl. (The prior behavior could allow unexpected matches when using some versions of Winsock: CVE-2013-6320.) [RT #34687]
- 3655. [cleanup] Simplify TCP message processing when requesting a zone transfer. [RT #34825]
- 3654. [bug] Address race condition with manual notify requests. [RT #34806]
- 3653. [func] Create delegations for all "children" of empty zones except "forward first". [RT #34826]
- 3652. [bug] Address bug with rpz-drop policy. [RT #34816]
- 3651. [tuning] Adjust when a master server is deemed unreachable. [RT #27075]
- 3650. [tuning] Use separate rate limiting queues for refresh and notify requests. [RT #30589]
- 3649. [cleanup] Include a comment in .nzf files, giving the name of the associated view. [RT #34765]
- 3648. [test] Updated the ATF test framework to version 0.17. [RT #25627]

(continues on next page)

(continued from previous page)

- 3647. [bug] Address a race condition when shutting down a zone.  
[RT #34750]
- 3646. [bug] Journal filename string could be set incorrectly,  
causing garbage in log messages. [RT #34738]
- 3645. [protocol] Use case sensitive compression when responding to  
queries. [RT #34737]
- 3644. [protocol] Check that EDNS subnet client options are well formed.  
[RT #34718]
- 3643. [doc] Clarify RRL "slip" documentation.
- 3642. [func] Allow externally generated DNSKEY to be imported  
into the DNSKEY management framework. A new tool  
dnssec-importkey is used to do this. [RT #34698]
- 3641. [bug] Handle changes to sig-validity-interval settings  
better. [RT #34625]
- 3640. [bug] ndots was not being checked when searching. Only  
continue searching on NXDOMAIN responses. Add the  
ability to specify ndots to nslookup. [RT #34711]
- 3639. [bug] Treat type 65533 (KEYDATA) as opaque except when used  
in a key zone. [RT #34238]
- 3638. [cleanup] Add the ability to handle ENOPROTOOPT in case it is  
encountered. [RT #34668]
- 3637. [bug] 'allow-query-on' was checking the source address  
rather than the destination address. [RT #34590]
- 3636. [bug] Automatic empty zones now behave better with  
forward only "zones" beneath them. [RT #34583]
- 3635. [bug] Signatures were not being removed from a zone with  
only KSK keys for an algorithm. [RT #34439]
- 3634. [func] Report build-id in rndc status. Report build-id  
when building from a git repository. [RT #20422]
- 3633. [cleanup] Refactor OPT processing in named to make it easier  
to support new EDNS options. [RT #34414]
- 3632. [bug] Signature from newly inactive keys were not being  
removed. [RT #32178]
- 3631. [bug] Remove spurious warning about missing signatures when  
qtype is SIG. [RT #34600]

(continues on next page)

(continued from previous page)

- 3630. [bug] Ensure correct ID computation for MD5 keys. [RT #33033]
- 3629. [func] Allow the printing of cryptographic fields in DNSSEC records by dig to be suppressed (dig +nocrypto). [RT #34534]
- 3628. [func] Report DNSKEY key id's when dumping the cache. [RT #34533]
- 3627. [bug] RPZ changes were not effective on slaves. [RT #34450]
- 3626. [func] dig: NSID output now easier to read. [RT #21160]
- 3625. [bug] Don't send notify messages to machines outside of the test setup.
- 3624. [bug] Look for 'json\_object\_new\_int64' when looking for a the json library. [RT #34449]
- 3623. [placeholder]
- 3622. [tuning] Eliminate an unnecessary lock when incrementing cache statistics. [RT #34339]
- 3621. [security] Incorrect bounds checking on private type 'keydata' can lead to a remotely triggerable REQUIRE failure (CVE-2013-4854). [RT #34238]
- 3620. [func] Added "rpz-client-ip" policy triggers, enabling RPZ responses to be configured on the basis of the client IP address; this can be used, for example, to blacklist misbehaving recursive or stub resolvers. [RT #33605]
- 3619. [bug] Fixed a bug in RPZ with "recursive-only no;" [RT #33776]
- 3618. [func] "rndc reload" now checks modification times of include files as well as master files to determine whether to skip reloading a zone. [RT #33936]
- 3617. [bug] Named was failing to answer queries during "rndc reload" [RT #34098]
- 3616. [bug] Change #3613 was incomplete. [RT #34177]
- 3615. [cleanup] "configure" now finishes by printing a summary of optional BIND features and whether they are active or inactive. ("configure --enable-full-report" increases the verbosity of the summary.) [RT #31777]
- 3614. [port] Check for <linux/types.h>. [RT #34162]

(continues on next page)

(continued from previous page)

- 3613. [bug] named could crash when deleting inline-signing zones with "rndc delzone". [RT #34066]
- 3612. [port] Check whether to use -ljson or -ljson-c. [RT #34115]
- 3611. [bug] Improved resistance to a theoretical authentication attack based on differential timing. [RT #33939]
- 3610. [cleanup] win32: Some executables had been omitted from the installer. [RT #34116]
- 3609. [bug] Corrected a possible deadlock in applications using the export version of the isc\_app API. [RT #33967]
- 3608. [port] win32: added todos.pl script to ensure all text files the win32 build depends on are converted to DOS newline format. [RT #22067]
- 3607. [bug] dnssec-keygen had broken 'Invalid keyfile' error message. [RT #34045]
- 3606. [func] "rndc flushtree" now flushes matching records in the address database and bad cache as well as the DNS cache. (Previously only the DNS cache was flushed.) [RT #33970]
- 3605. [port] win32: Addressed several compatibility issues with newer versions of Visual Studio. [RT #33916]
- 3604. [bug] Fixed a compile-time error when building with JSON but not XML. [RT #33959]
- 3603. [bug] Install <isc/stat.h>. [RT #33956]
- 3602. [contrib] Added DLZ Perl module, allowing Perl scripts to integrate with named and serve DNS data. (Contributed by John Eaglesham of Yahoo.)
- 3601. [bug] Added to PKCS#11 openssl patches a value len attribute in DH derive key. [RT #33928]
- 3600. [cleanup] dig: Fixed a typo in the warning output when receiving an oversized response. [RT #33910]
- 3599. [tuning] Check for pointer equivalence in name comparisons. [RT #18125]
- 3598. [cleanup] Improved portability of map file code. [RT #33820]
- 3597. [bug] Ensure automatic-resigning heaps are reconstructed when loading zones in map format. [RT #33381]

(continues on next page)

(continued from previous page)

- 3596. [port] Updated win32 build documentation, added dnssec-verify. [RT #22067]
- 3595. [port] win32: Fix build problems introduced by change #3550. [RT #33807]
- 3594. [maint] Update config.guess and config.sub. [RT #33816]
- 3593. [func] Update EDNS processing to better track remote server capabilities. [RT #30655]
- 3592. [doc] Moved documentation of rndc command options to the rndc man page. [RT #33506]
- 3591. [func] Use CRC-64 to detect map file corruption at load time. [RT #33746]
- 3590. [bug] When using RRL on recursive servers, defer rate-limiting until after recursion is complete; also, use correct rcode for slipped NXDOMAIN responses. [RT #33604]
- 3589. [func] Report serial numbers in when starting zone transfers. Report accepted NOTIFY requests including serial. [RT #33037]
- 3588. [bug] dig: addressed a memory leak in the sigchase code that could cause a shutdown crash. [RT #33733]
- 3587. [func] 'named -g' now checks the logging configuration but does not use it. [RT #33473]
- 3586. [bug] Handle errors in xmlDocDumpFormatMemoryEnc. [RT #33706]
- 3585. [func] "rndc delzone -clean" option removes zone files when deleting a zone. [RT #33570]
- 3584. [security] Caching data from an incompletely signed zone could trigger an assertion failure in resolver.c (CVE-2013-3919). [RT #33690]
- 3583. [bug] Address memory leak in GSS-API processing [RT #33574]
- 3582. [bug] Silence false positive warning regarding missing file directive for inline slave zones. [RT #33662]
- 3581. [bug] Changed the tcp-listen-queue default to 10. [RT #33029]
- 3580. [bug] Addressed a possible race in acache.c [RT #33602]
- 3579. [maint] Updates to PKCS#11 openssl patches, supporting

(continues on next page)

(continued from previous page)

		versions 0.9.8y, 1.0.0k, 1.0.1e [RT #33463]
3578.	[bug]	'rndc -c file' now fails if 'file' does not exist. [RT #33571]
3577.	[bug]	Handle zero TTL values better. [RT #33411]
3576.	[bug]	Address a shutdown race when validating. [RT #33573]
3575.	[func]	Changed the logging category for RRL events from 'queries' to 'query-errors'. [RT #33540]
3574.	[doc]	The 'hostname' keyword was missing from server-id description in the named.conf man page. [RT #33476]
3573.	[bug]	"rndc addzone" and "rndc delzone" incorrectly handled zone names containing punctuation marks and other nonstandard characters. [RT #33419]
3572.	[func]	Threads are now enabled by default on most operating systems. [RT #25483]
3571.	[bug]	Address race condition in dns_client_startresolve(). [RT #33234]
3570.	[bug]	Check internal pointers are valid when loading map files. [RT #33403]
3569.	[contrib]	Ported mysql DLZ driver to dynamically-loadable module, and added multithread support. [RT #33394]
3568.	[cleanup]	Add a product description line to the version file, to be reported by named -v/-V. [RT #33366]
3567.	[bug]	Silence clang static analyzer warnings. [RT #33365]
3566.	[func]	Log when forwarding updates to master. [RT #33240]
3565.	[placeholder]	
3564.	[bug]	Improved handling of corrupted map files. [RT #33380]
3563.	[contrib]	zone2sqlite failed with some table names. [RT #33375]
3562.	[func]	Update map file header format to include a SHA-1 hash of the database content, so that corrupted map files can be rejected at load time. [RT #32459]
3561.	[bug]	dig: issue a warning if an EDNS query returns FORMERR or NOTIMP. Adjust usage message. [RT #33363]
3560.	[bug]	isc-config.sh did not honor includedir and libdir

(continues on next page)

(continued from previous page)

		when set via configure. [RT #33345]
3559.	[func]	Check that both forms of Sender Policy Framework records exist or do not exist. [RT #33355]
3558.	[bug]	IXFR of a DLZ stored zone was broken. [RT #33331]
3557.	[bug]	Reloading redirect zones was broken. [RT #33292]
3556.	[maint]	Added AAAA for D.ROOT-SERVERS.NET.
3555.	[bug]	Address theoretical race conditions in acache.c (change #3553 was incomplete). [RT #33252]
3554.	[bug]	RRL failed to correctly rate-limit upward referrals and failed to count dropped error responses in the statistics. [RT #33225]
3553.	[bug]	Address suspected double free in acache. [RT #33252]
3552.	[bug]	Wrong getopt option string for 'nsupdate -r'. [RT #33280]
3551.	[bug]	resolver.querydscp[46] were uninitialized. [RT #32686]
3550.	[func]	Unified the internal and export versions of the BIND libraries, allowing external clients to use the same libraries as BIND. [RT #33131]
3549.	[doc]	Documentation for "request-nsid" was missing. [RT #33153]
3548.	[bug]	The NSID request code in resolver.c was broken resulting in invalid EDNS options being sent. [RT #33153]
3547.	[bug]	Some malformed unknown rdata records were not properly detected and rejected. [RT #33129]
3546.	[func]	Add EUI48 and EUI64 types. [RT #33082]
3545.	[bug]	RRL slip behavior was incorrect when set to 1. [RT #33111]
3544.	[contrib]	check5011.pl: Script to report the status of managed keys as recorded in managed-keys.bind. Contributed by Tony Finch <dot@dotat.at>
3543.	[bug]	Update socket structure before attaching to socket manager after accept. [RT #33084]
3542.	[placeholder]	

(continues on next page)

(continued from previous page)

- 3541. [bug] Parts of libdns were not properly initialized when built in libexport mode. [RT #33028]
- 3540. [test] libt\_api: t\_info and t\_assert were not thread safe.
- 3539. [port] win32: timestamp format didn't match other platforms.
- 3538. [test] Running "make test" now requires loopback interfaces to be set up. [RT #32452]
- 3537. [tuning] Slave zones, when updated, now send NOTIFY messages to peers before being dumped to disk rather than after. [RT #27242]
- 3536. [func] Add support for setting Differentiated Services Code Point (DSCP) values in named. Most configuration options which take a "port" option (e.g., listen-on, forwarders, also-notify, masters, notify-source, etc) can now also take a "dscp" option specifying a code point for use with outgoing traffic, if supported by the underlying OS. [RT #27596]
- 3535. [bug] Minor win32 cleanups. [RT #32962]
- 3534. [bug] Extra text after an embedded NULL was ignored when parsing zone files. [RT #32699]
- 3533. [contrib] query-loc-0.4.0: memory leaks. [RT #32960]
- 3532. [contrib] zkt: fixed buffer overrun, resource leaks. [RT #32960]
- 3531. [bug] win32: A uninitialized value could be returned on out of memory. [RT #32960]
- 3530. [contrib] Better RTT tracking in queryperf. [RT #30128]
- 3529. [func] Named now listens on both IPv4 and IPv6 interfaces by default. Named previously only listened on IPv4 interfaces by default unless named was running in IPv6 only mode. [RT #32945]
- 3528. [func] New "dnssec-coverage" command scans the timing metadata for a set of DNSSEC keys and reports if a lapse in signing coverage has been scheduled inadvertently. (Note: This tool depends on python; it will not be built or installed on systems that do not have a python interpreter.) [RT #28098]
- 3527. [compat] Add a URI to allow applications to explicitly request a particular XML schema from the statistics

(continues on next page)

(continued from previous page)

		channel, returning 404 if not supported. [RT #32481]
3526.	[cleanup]	Set up dependencies for unit tests correctly during build. [RT #32803]
3525.	[func]	Support for additional signing algorithms in rndc: hmac-sha1, -sha224, -sha256, -sha384, and -sha512. The -A option to rndc-confgen can be used to select the algorithm for the generated key. (The default is still hmac-md5; this may change in a future release.) [RT #20363]
3524.	[func]	Added an alternate statistics channel in JSON format, when the server is built with the json-c library: http://[address]:[port]/json. [RT #32630]
3523.	[contrib]	Ported filesystem and ldap DLZ drivers to dynamically-loadable modules, and added the "wildcard" module based on a contribution from Vadim Goncharov <vgoncharov@nic.ru>. [RT #23569]
3522.	[bug]	DLZ lookups could fail to return SERVFAIL when they ought to. [RT #32685]
3521.	[bug]	Address memory leak in opensslcda_link.c. [RT #32249]
3520.	[bug]	'mctx' was not being referenced counted in some places where it should have been. [RT #32794]
3519.	[func]	Full replay protection via four-way handshake is now mandatory for rndc clients. Very old versions of rndc will no longer work. [RT #32798]
3518.	[bug]	Increase the size of dns_rrl_key.s.rtype by one bit so that all dns_rrl_rtype_t enum values fit regardless of whether it is treated as signed or unsigned by the compiler. [RT #32792]
3517.	[bug]	Reorder destruction to avoid shutdown race. [RT #32777]
3516.	[placeholder]	
3515.	[port]	'%T' is not portable in strftime(). [RT #32763]
3514.	[bug]	The ranges for valid key sizes in ddns-confgen and rndc-confgen were too constrained. Keys up to 512 bits are now allowed for most algorithms, and up to 1024 bits for hmac-sha384 and hmac-sha512. [RT #32753]
3513.	[func]	"dig -u" prints times in microseconds rather than milliseconds. [RT #32704]

(continues on next page)

(continued from previous page)

- 3512. [func] "rndc validation check" reports the current status of DNSSEC validation. [RT #21397]
- 3511. [doc] Improve documentation of redirect zones. [RT #32756]
- 3510. [func] "rndc status" and XML statistics channel now report server start and reconfiguration times. [RT #21048]
- 3509. [cleanup] Added a product line to version file to allow for easy naming of different products (BIND vs BIND ESV, for example). [RT #32755]
- 3508. [contrib] queryperf was incorrectly rejecting the -T option. [RT #32338]
- 3507. [bug] Statistics channel XSL had a glitch when attempting to chart query data before any queries had been received. [RT #32620]
- 3506. [func] When setting "max-cache-size" and "max-acache-size", the keyword "unlimited" is no longer defined as equal to 4 gigabytes (except on 32-bit platforms); it means literally unlimited. [RT #32358]
- 3505. [bug] When setting "max-cache-size" and "max-acache-size", larger values than 4 gigabytes could not be set explicitly, though larger sizes were available when setting cache size to 0. This has been corrected; the full range is now available. [RT #32358]
- 3504. [func] Add support for ACLs based on geographic location, using MaxMind GeoIP databases. Based on code contributed by Ken Brownfield <kb@slide.com>. [RT #30681]
- 3503. [doc] Clarify size\_spec syntax. [RT #32449]
- 3502. [func] zone-statistics: "no" is now a synonym for "none", instead of "terse". [RT #29165]
- 3501. [func] zone-statistics now takes three options: full, terse, and none. "yes" and "no" are retained as synonyms for full and terse, respectively. [RT #29165]
- 3500. [security] Support NAPTR regular expression validation on all platforms without using libregex, which can be vulnerable to memory exhaustion attack (CVE-2013-2266). [RT #32688]

- 3499. [doc] Corrected ARM documentation of built-in zones.  
[RT #32694]
- 3498. [bug] zone statistics for zones which matched a potential  
empty zone could have their zone-statistics setting  
overridden.
- 3497. [func] When deleting a slave/stub zone using 'rndc delzone'  
report the files that were being used so they can  
be cleaned up if desired. [RT #27899]
- 3496. [placeholder]
- 3495. [func] Support multiple response-policy zones (up to 32),  
while improving RPZ performance. "response-policy"  
syntax now includes a "min-ns-dots" clause, with  
default 1, to exclude top-level domains from  
NSIP and NSDNAME checking. --enable-rpz-nsip and  
--enable-rpz-nsdname are now the default. [RT #32251]
- 3494. [func] DNS RRL: Blunt the impact of DNS reflection and  
amplification attacks by rate-limiting substantially-  
identical responses. [RT #28130]
- 3493. [contrib] Added BDBHPT dynamically-loadable DLZ module,  
contributed by Mark Goldfinch. [RT #32549]
- 3492. [bug] Fixed a regression in zone loading performance  
due to lock contention. [RT #30399]
- 3491. [bug] Slave zones using inline-signing must specify a  
file name. [RT #31946]
- 3490. [bug] When logging RDATA during update, truncate if it's  
too long. [RT #32365]
- 3489. [bug] --enable-developer now turns on ISC\_LIST\_CHECKINIT.  
dns\_dlzcreate() failed to properly initialize  
dlzdb.link. When cloning a rdataset do not copy  
the link contents. [RT #32651]
- 3488. [bug] Use after free error with DH generated keys. [RT #32649]
- 3487. [bug] Change 3444 was not complete. There was a additional  
place where the NOQNAME proof needed to be saved.  
[RT #32629]
- 3486. [bug] named could crash when using TKEY-negotiated keys  
that had been deleted and then recreated. [RT #32506]
- 3485. [cleanup] Only compile openssl\_gostlink.c if we support GOST.
- 3484. [bug] Some statistics were incorrectly rendered in XML.

(continues on next page)

(continued from previous page)

		[RT #32587]
3483.	[placeholder]	
3482.	[func]	dig +nssearch now prints name servers that don't have address records (missing AAAA or A, or the name doesn't exist). [RT #29348]
3481.	[cleanup]	Removed use of const const in atf.
3480.	[bug]	Silence logging noise when setting up zone statistics. [RT #32525]
3479.	[bug]	Address potential memory leaks in gssapi support code. [RT #32405]
3478.	[port]	Fix a build failure in strict C99 environments [RT #32475]
3477.	[func]	Expand logging when adding records via DDNS update [RT #32365]
3476.	[bug]	"rndc zonestatus" could report a spurious "not found" error on inline-signing zones. [RT #29226]
3475.	[cleanup]	Changed name of 'map' zone file format (previously 'fast'). [RT #32458]
3474.	[bug]	nsupdate could assert when the local and remote address families didn't match. [RT #22897]
3473.	[bug]	dnssec-signzone/verify could incorrectly report an error condition due to an empty node above an opt-out delegation lacking an NSEC3. [RT #32072]
3472.	[bug]	The active-connections counter in the socket statistics could underflow. [RT #31747]
3471.	[bug]	The number of UDP dispatches now defaults to the number of CPUs even if -n has been set to a higher value. [RT #30964]
3470.	[bug]	Slave zones could fail to dump when successfully refreshing after an initial failure. [RT #31276]
3469.	[bug]	Handle DLZ lookup failures more gracefully. Improve backward compatibility between versions of DLZ dlopen API. [RT #32275]
3468.	[security]	RPZ rules to generate A records (but not AAAA records) could trigger an assertion failure when used in conjunction with DNS64 (CVE-2012-5689). [RT #32141]

(continues on next page)

(continued from previous page)

- 3467. [bug] Added checks in dnssec-keygen and dnssec-settime to check for delete date < inactive date. [RT #31719]
- 3466. [contrib] Corrected the DNS\_CLIENTINFOMETHODS\_VERSION check in DLZ example driver. [RT #32275]
- 3465. [bug] Handle isolated reserved ports. [RT #31778]
- 3464. [maint] Updates to PKCS#11 openssl patches, supporting versions 0.9.8x, 1.0.0j, 1.0.1c [RT #29749]
- 3463. [doc] Clarify managed-keys syntax in ARM. [RT #32232]
- 3462. [doc] Clarify server selection behavior of dig when using -4 or -6 options. [RT #32181]
- 3461. [bug] Negative responses could incorrectly have AD=1 set. [RT #32237]
- 3460. [bug] Only link against readline where needed. [RT #29810]
- 3459. [func] Added -J option to named-checkzone/named-compilezone to specify the path to the journal file. [RT #30958]
- 3458. [bug] Return FORMERR when presented with a overly long domain named in a request. [RT #29682]
- 3457. [protocol] Add ILNP records (NID, LP, L32, L64). [RT #31836]
- 3456. [port] g++47: ATF failed to compile. [RT #32012]
- 3455. [contrib] queryperf: fix getopt option list. [RT #32338]
- 3454. [port] sparc64: improve atomic support. [RT #25182]
- 3453. [bug] 'rndc addzone' of a zone with 'inline-signing yes;' failed. [RT #31960]
- 3452. [bug] Accept duplicate singleton records. [RT #32329]
- 3451. [port] Increase per thread stack size from 64K to 1M. [RT #32230]
- 3450. [bug] Stop logfileconfig system test spam system logs. [RT #32315]
- 3449. [bug] gen.c: use the pre-processor to construct format strings so that compiler can perform sanity checks; check the sprintf results. [RT #17576]
- 3448. [bug] The allow-query-on ACL was not processed correctly.

(continues on next page)

(continued from previous page)

- [RT #29486]
- 3447. [port] Add support for libxml2-2.9.x [RT #32231]
- 3446. [port] win32: Add source ID (see change #3400) to build. [RT #31683]
- 3445. [bug] Warn about zone files with blank owner names immediately after \$ORIGIN directives. [RT #31848]
- 3444. [bug] The NOQNAME proof was not being returned from cached insecure responses. [RT #21409]
- 3443. [bug] ddns-confgen: Some TSIG algorithms were incorrectly rejected when generating keys. [RT #31927]
- 3442. [port] Net::DNS 0.69 introduced a non backwards compatible change. [RT #32216]
- 3441. [maint] D.ROOT-SERVERS.NET is now 199.7.91.13.
- 3440. [bug] Reorder get\_key\_struct to not trigger a assertion when cleaning up due to out of memory error. [RT #32131]
- 3439. [placeholder]
- 3438. [bug] Don't accept unknown data escape in quotes. [RT #32031]
- 3437. [bug] isc\_buffer\_init -> isc\_buffer\_constinit to initialize buffers with constant data. [RT #32064]
- 3436. [bug] Check malloc/calloc return values. [RT #32088]
- 3435. [bug] Cross compilation support in configure was broken. [RT #32078]
- 3434. [bug] Pass client info to the DLZ findzone() entry point in addition to lookup(). This makes it possible for a database to answer differently whether it's authoritative for a name depending on the address of the client. [RT #31775]
- 3433. [bug] dlz\_findzone() did not correctly handle ISC\_R\_NOMORE. [RT #31172]
- 3432. [func] Multiple DLZ databases can now be configured. DLZ databases are searched in the order configured, unless set to "search no", in which case a zone can be configured to be retrieved from a particular DLZ database by using a "dlz <name>" option in the zone statement. DLZ databases can support type "master" and "redirect" zones.

(continues on next page)

(continued from previous page)

		[RT #27597]
3431.	[bug]	ddns-confgen: Some valid key algorithms were not accepted. [RT #31927]
3430.	[bug]	win32: isc_time_formatISO8601 was missing the 'T' between the date and time. [RT #32044]
3429.	[bug]	dns_zone_getserial2 could a return success without returning a valid serial. [RT #32007]
3428.	[cleanup]	dig: Add timezone to date output. [RT #2269]
3427.	[bug]	dig +trace incorrectly displayed name server addresses instead of names. [RT #31641]
3426.	[bug]	dnssec-checkds: Clearer output when records are not found. [RT #31968]
3425.	[bug]	"acacheentry" reference counting was broken resulting in use after free. [RT #31908]
3424.	[func]	dnssec-dsfromkey now emits the hash without spaces. [RT #31951]
3423.	[bug]	"rndc signing -nsec3param" didn't accept the full range of possible values. Address portability issues. [RT #31938]
3422.	[bug]	Added a clear error message for when the SOA does not match the referral. [RT #31281]
3421.	[bug]	Named loops when re-signing if all keys are offline. [RT #31916]
3420.	[bug]	Address VPATH compilation issues. [RT #31879]
3419.	[bug]	Memory leak on validation cancel. [RT #31869]
3418.	[func]	New XML schema (version 3.0) for the statistics channel adds query type statistics at the zone level, and flattens the XML tree and uses compressed format to optimize parsing. Includes new XSL that permits charting via the Google Charts API on browsers that support javascript in XSL. The old XML schema has been deprecated. [RT #30023]
3417.	[placeholder]	
3416.	[bug]	Named could die on shutdown if running with 128 UDP dispatches per interface. [RT #31743]

(continues on next page)

(continued from previous page)

- 3415. [bug] named could die with a REQUIRE failure if a validation was canceled. [RT #31804]
- 3414. [bug] Address locking issues found by Coverity. [RT #31626]
- 3413. [func] Record the number of DNS64 AAAA RRsets that have been synthesized. [RT #27636]
- 3412. [bug] Copy timeval structure from control message data. [RT #31548]
- 3411. [tuning] Use IPV6\_USE\_MIN\_MTU or equivalent with TCP in addition to UDP. [RT #31690]
- 3410. [bug] Addressed Coverity warnings. [RT #31626]
- 3409. [contrib] contrib/dane/mkdane.sh: Tool to generate TLSA RR's from X.509 certificates, for use with DANE (DNS-based Authentication of Named Entities). [RT #30513]
- 3408. [bug] Some DNSSEC-related options (update-check-ksk, dnssec-loadkeys-interval, dnssec-dnskey-kskonly) are now legal in slave zones as long as inline-signing is in use. [RT #31078]
- 3407. [placeholder]
- 3406. [bug] mem.c: Fix compilation errors when building with ISC\_MEM\_TRACKLINES or ISC\_MEMPOOL\_NAMES disabled. Also, ISC\_MEM\_DEBUG is no longer optional. [RT #31559]
- 3405. [bug] Handle time going backwards in aCACHE. [RT #31253]
- 3404. [bug] dnssec-signzone: When re-signing a zone, remove RRSIG and NSEC records from nodes that used to be in-zone but are now below a zone cut. [RT #31556]
- 3403. [bug] Silence noisy OpenSSL logging. [RT #31497]
- 3402. [test] The IPv6 interface numbers used for system tests were incorrect on some platforms. [RT #25085]
- 3401. [bug] Addressed Coverity warnings. [RT #31484]
- 3400. [cleanup] "named -V" can now report a source ID string, defined in the "srcid" file in the build tree and normally set to the most recent git hash. [RT #31494]
- 3399. [port] netbsd: rename 'bool' parameter to avoid namespace clash. [RT #31515]

(continues on next page)

(continued from previous page)

3398.	[bug]	SOA parameters were not being updated with inline signed zones if the zone was modified while the server was offline. [RT #29272]
3397.	[bug]	dig crashed when using +nssearch with +tcp. [RT #25298]
3396.	[bug]	OPT records were incorrectly removed from signed, truncated responses. [RT #31439]
3395.	[protocol]	Add RFC 6598 reverse zones to built in empty zones list, 64.100.IN-ADDR.ARPA ... 127.100.IN-ADDR.ARPA. [RT #31336]
3394.	[bug]	Adjust 'successfully validated after lower casing signer' log level and category. [RT #31414]
3393.	[bug]	'host -C' could core dump if REFUSED was received. [RT #31381]
3392.	[func]	Keep statistics on REFUSED responses. [RT #31412]
3391.	[bug]	A DNSKEY lookup that encountered a CNAME failed. [RT #31262]
3390.	[bug]	Silence clang compiler warnings. [RT #30417]
3389.	[bug]	Always return NOERROR (not 0) in TSIG. [RT #31275]
3388.	[bug]	Fixed several Coverity warnings. Note: This change includes a fix for a bug that was subsequently determined to be an exploitable security vulnerability, CVE-2012-5688: named could die on specific queries with dns64 enabled. [RT #30996]
3387.	[func]	DS digest can be disabled at runtime with disable-ds-digests. [RT #21581]
3386.	[bug]	Address locking violation when generating new NSEC / NSEC3 chains. [RT #31224]
3385.	[bug]	named-checkconf didn't detect missing master lists in also-notify clauses. [RT #30810]
3384.	[bug]	Improved logging of crypto errors. [RT #30963]
3383.	[security]	A certain combination of records in the RBT could cause named to hang while populating the additional section of a response. [RT #31090]
3382.	[bug]	SOA query from slave used use-v6-udp-ports range, if set, regardless of the address family in use.

(continues on next page)

(continued from previous page)

		[RT #24173]
3381.	[contrib]	Update queryperf to support more RR types. [RT #30762]
3380.	[bug]	named could die if a nonexistent master list was referenced in a also-notify. [RT #31004]
3379.	[bug]	isc_interval_zero and isc_time_epoch should be "const (type)* const". [RT #31069]
3378.	[bug]	Handle missing 'managed-keys-directory' better. [RT #30625]
3377.	[bug]	Removed spurious newline from NSEC3 multiline output. [RT #31044]
3376.	[bug]	Lack of EDNS support was being recorded without a successful response. [RT #30811]
3375.	[bug]	'rndc dumpdb' failed on empty caches. [RT #30808]
3374.	[bug]	isc_parse_uint32 failed to return a range error on systems with 64 bit longs. [RT #30232]
3373.	[bug]	win32: open raw files in binary mode. [RT #30944]
3372.	[bug]	Silence spurious "deleted from unreachable cache" messages. [RT #30501]
3371.	[bug]	AD=1 should behave like DO=1 when deciding whether to add NS RRsets to the additional section or not. [RT #30479]
3370.	[bug]	Address use after free while shutting down. [RT #30241]
3369.	[bug]	nsupdate terminated unexpectedly in interactive mode if built with readline support. [RT #29550]
3368.	[bug]	<dns/iptable.h>, <dns/private.h> and <dns/zone.h> were not C++ safe.
3367.	[bug]	dns_dnsseckey_create() result was not being checked. [RT #30685]
3366.	[bug]	Fixed Read-After-Write dependency violation for IA64 atomic operations. [RT #25181]
3365.	[bug]	Removed spurious newlines from log messages in zone.c [RT #30675]
3364.	[security]	Named could die on specially crafted record.

(continues on next page)

(continued from previous page)

		[RT #30416]
3363.	[bug]	Need to allow "forward" and "fowarders" options in static-stub zones; this had been overlooked. [RT #30482]
3362.	[bug]	Setting some option values to 0 in named.conf could trigger an assertion failure on startup. [RT #27730]
3361.	[bug]	"rndc signing -nsec3param" didn't work correctly when salt was set to '-' (no salt). [RT #30099]
3360.	[bug]	'host -w' could die. [RT #18723]
3359.	[bug]	An improperly-formed TSIG secret could cause a memory leak. [RT #30607]
3358.	[placeholder]	
3357.	[port]	Add support for libxml2-2.8.x [RT #30440]
3356.	[bug]	Cap the TTL of signed RRsets when RRSIGs are approaching their expiry, so they don't remain in caches after expiry. [RT #26429]
3355.	[port]	Use more portable awk in verify system test.
3354.	[func]	Improve OpenSSL error logging. [RT #29932]
3353.	[bug]	Use a single task for task exclusive operations. [RT #29872]
3352.	[bug]	Ensure that learned server attributes timeout of the adb cache. [RT #29856]
3351.	[bug]	isc_mem_put and isc_mem_putanddetach didn't report caller if either ISC_MEM_DEBUGSIZE or ISC_MEM_DEBUGCTX memory debugging flags are set. [RT #30243]
3350.	[bug]	Memory read overrun in isc__mem_reallocate if ISC_MEM_DEBUGCTX memory debugging flag is set. [RT #30240]
3349.	[bug]	Change #3345 was incomplete. [RT #30233]
3348.	[bug]	Prevent RRSIG data from being cached if a negative record matching the covering type exists at a higher trust level. Such data already can't be retrieved from the cache since change 3218 -- this prevents it being inserted into the cache as well. [RT #26809]

(continues on next page)

(continued from previous page)

3347. [bug] dnssec-settime: Issue a warning when writing a new private key file would cause a change in the permissions of the existing file. [RT #27724]
3346. [security] Bad-cache data could be used before it was initialized, causing an assert. [RT #30025]
3345. [bug] Addressed race condition when removing the last item or inserting the first item in an ISC\_QUEUE. [RT #29539]
3344. [func] New "dnssec-checkds" command checks a zone to determine which DS records should be published in the parent zone, or which DLV records should be published in a DLV zone, and queries the DNS to ensure that it exists. (Note: This tool depends on python; it will not be built or installed on systems that do not have a python interpreter.) [RT #28099]
3343. [placeholder]
3342. [bug] Change #3314 broke saving of stub zones to disk resulting in excessive cpu usage in some cases. [RT #29952]
3341. [func] New "dnssec-verify" command checks a signed zone to ensure correctness of signatures and of NSEC/NSEC3 chains. [RT #23673]
3340. [func] Added new 'map' zone file format, which is an image of a zone database that can be loaded directly into memory via mmap(), allowing much faster zone loading. (Note: Because of pointer sizes and other considerations, this file format is platform-dependent; 'map' zone files cannot always be transferred from one server to another.) [RT #25419]
3339. [func] Allow the maximum supported rsa exponent size to be specified: "max-rsa-exponent-size <value>;" [RT #29228]
3338. [bug] Address race condition in units tests: asyncload\_zone and asyncload\_zt. [RT #26100]
3337. [bug] Change #3294 broke support for the multiple keys in controls. [RT #29694]
3336. [func] Maintain statistics for RRsets tagged as "stale". [RT #29514]
3335. [func] nslookup: return a nonzero exit code when unable to get an answer. [RT #29492]

(continues on next page)

(continued from previous page)

- 3334. [bug] Hold a zone table reference while performing a asynchronous load of a zone. [RT #28326]
- 3333. [bug] Setting resolver-query-timeout too low can cause named to not recover if it loses connectivity. [RT #29623]
- 3332. [bug] Re-use cached DS rrsets if possible. [RT #29446]
- 3331. [security] dns\_rdataslab\_fromrdataset could produce bad rdataslabs. [RT #29644]
- 3330. [func] Fix missing signatures on NOERROR results despite RPZ rewriting. Also
  - add optional "recursive-only yes|no" to the response-policy statement
  - add optional "max-policy-ttl" to the response-policy statement to limit the false data that "recursive-only no" can introduce into resolvers' caches
  - add a RPZ performance test to bin/tests/system/rpz when queryperf is available.
  - the encoding of PASSTHRU action to "rpz-passthru". (The old encoding is still accepted.)
 [RT #26172]
- 3329. [bug] Handle RRSIG signer-name case consistently: We generate RRSIG records with the signer-name in lower case. We accept them with any case, but if they fail to validate, we try again in lower case. [RT #27451]
- 3328. [bug] Fixed inconsistent data checking in dst\_parse.c. [RT #29401]
- 3327. [func] Added 'filter-aaaa-on-v6' option; this is similar to 'filter-aaaa-on-v4' but applies to IPv6 connections. (Use "configure --enable-filter-aaaa" to enable this option.) [RT #27308]
- 3326. [func] Added task list statistics: task model, worker threads, quantum, tasks running, tasks ready. [RT #27678]
- 3325. [func] Report cache statistics: memory use, number of nodes, number of hash buckets, hit and miss counts. [RT #27056]
- 3324. [test] Add better tests for ADB stats [RT #27057]

(continues on next page)

(continued from previous page)

3323.	[func]	Report the number of buckets the resolver is using. [RT #27020]
3322.	[func]	Monitor the number of active TCP and UDP dispatches. [RT #27055]
3321.	[func]	Monitor the number of recursive fetches and the number of open sockets, and report these values in the statistics channel. [RT #27054]
3320.	[func]	Added support for monitoring of recursing client count. [RT #27009]
3319.	[func]	Added support for monitoring of ADB entry count and hash size. [RT #27057]
3318.	[tuning]	Reduce the amount of work performed while holding a bucket lock when finished with a fetch context. [RT #29239]
3317.	[func]	Add ECDSA support (RFC 6605). [RT #21918]
3316.	[tuning]	Improved locking performance when recursing. [RT #28836]
3315.	[tuning]	Use multiple dispatch objects for sending upstream queries; this can improve performance on busy multiprocessor systems by reducing lock contention. [RT #28605]
3314.	[bug]	The masters list could be updated while stub_callback or refresh_callback were using it. [RT #26732]
3313.	[protocol]	Add TLSA record type. [RT #28989]
3312.	[bug]	named-checkconf didn't detect a bad dns64 clients acl. [RT #27631]
3311.	[bug]	Abort the zone dump if zone->db is NULL in zone.c:zone_gotwritehandle. [RT #29028]
3310.	[test]	Increase table size for mutex profiling. [RT #28809]
3309.	[bug]	resolver.c:fctx_finddone() was not thread safe. [RT #27995]
3308.	[placeholder]	
3307.	[bug]	Add missing ISC_LANG_BEGINDECLS and ISC_LANG_ENDDECLS. [RT #28956]
3306.	[bug]	Improve DNS64 reverse zone performance. [RT #28563]

(continues on next page)

(continued from previous page)

- 3305. [func] Add wire format lookup method to sdb. [RT #28563]
- 3304. [bug] Use hmctx, not mctx when freeing rbtdb->heaps. [RT #28571]
- 3303. [bug] named could die when reloading. [RT #28606]
- 3302. [bug] dns\_dnssec\_findmatchingkeys could fail to find keys if the zone name contained character that required special mappings. [RT #28600]
- 3301. [contrib] Update queryperf to build on darwin. Add -R flag for non-recursive queries. [RT #28565]
- 3300. [bug] Named could die if gssapi was enabled in named.conf but was not compiled in. [RT #28338]
- 3299. [bug] Make SDB handle errors from database drivers better. [RT #28534]
- 3298. [bug] Named could dereference a NULL pointer in zmgr\_start\_xfrin\_ifquota if the zone was being removed. [RT #28419]
- 3297. [bug] Named could die on a malformed master file. [RT #28467]
- 3296. [bug] Named could die with a INSIST failure in client.c:exit\_check. [RT #28346]
- 3295. [bug] Adjust isc\_time\_secondsastimet range check to be more portable. [RT # 26542]
- 3294. [bug] isccc/cc.c:table\_fromwire failed to free alist on error. [RT #28265]
- 3293. [func] nsupdate: list supported type. [RT #28261]
- 3292. [func] Log messages in the axfr stream at debug 10. [RT #28040]
- 3291. [port] Fixed a build error on systems without ENOTSUP. [RT #28200]
- 3290. [bug] <isc/hmacsha.h> was not being installed. [RT #28169]
- 3289. [bug] 'rndc retransfer' failed for inline zones. [RT #28036]
- 3288. [bug] dlz\_destroy() function wasn't correctly registered by the DLZ dlopen driver. [RT #28056]
- 3287. [port] Update ans.pl to work with Net::DNS 0.68. [RT #28028]

(continues on next page)

(continued from previous page)

- 3286. [bug] Managed key maintenance timer could fail to start after 'rndc reconfig'. [RT #26786]
- 3285. [bug] val-frdataset was incorrectly disassociated in proveunsecure after calling startfinddlvsep. [RT #27928]
- 3284. [bug] Address race conditions with the handling of rbtnode.deadlink. [RT #27738]
- 3283. [bug] Raw zones with with more than 512 records in a RRset failed to load. [RT #27863]
- 3282. [bug] Restrict the TTL of NS RRset to no more than that of the old NS RRset when replacing it. [RT #27792] [RT #27884]
- 3281. [bug] SOA refresh queries could be treated as cancelled despite succeeding over the loopback interface. [RT #27782]
- 3280. [bug] Potential double free of a rdataset on out of memory with DNS64. [RT #27762]
- 3279. [bug] Hold a internal reference to the zone while performing a asynchronous load. Address potential memory leak if the asynchronous is cancelled. [RT #27750]
- 3278. [bug] Make sure automatic key maintenance is started when "auto-dnssec maintain" is turned on during "rndc reconfig". [RT #26805]
- 3277. [bug] win32: isc\_socket\_dup is not implemented. [RT #27696]
- 3276. [bug] win32: ns\_os\_openfile failed to return NULL on safe\_open failure. [RT #27696]
- 3275. [bug] Corrected rndc -h output; the 'rndc sync -clean' option had been misspelled as '-clear'. (To avoid future confusion, both options now work.) [RT #27173]
- 3274. [placeholder]
- 3273. [bug] AAAA responses could be returned in the additional section even when filter-aaaa-on-v4 was in use. [RT #27292]
- 3272. [func] New "rndc zonestatus" command prints information about the specified zone. [RT #21671]
- 3271. [port] darwin: mkstymtbl is not always stable, loop several

(continues on next page)

(continued from previous page)

times before giving up. mksymtbl was using non portable perl to covert 64 bit hex strings. [RT #27653]

--- 9.9.0rc2 released ---

- 3270. [bug] "rndc reload" didn't reuse existing zones correctly when inline-signing was in use. [RT #27650]
- 3269. [port] darwin 11 and later now built threaded by default.
- 3268. [bug] Convert RRSIG expiry times to 64 timestamps to work out the earliest expiry time. [RT #23311]
- 3267. [bug] Memory allocation failures could be mis-reported as unexpected error. New ISC\_R\_UNSET result code. [RT #27336]
- 3266. [bug] The maximum number of NSEC3 iterations for a DNSKEY RRset was not being properly computed. [RT #26543]
- 3265. [bug] Corrected a problem with lock ordering in the inline-signing code. [RT #27557]
- 3264. [bug] Automatic regeneration of signatures in an inline-signing zone could stall when the server was restarted. [RT #27344]
- 3263. [bug] "rndc sync" did not affect the unsigned side of an inline-signing zone. [RT #27337]
- 3262. [bug] Signed responses were handled incorrectly by RPZ. [RT #27316]
- 3261. [func] RRset ordering now defaults to random. [RT #27174]
- 3260. [bug] "rrset-order cyclic" could appear not to rotate for some query patterns. [RT #27170/27185]

--- 9.9.0rc1 released ---

- 3259. [bug] named-compilezone: Suppress "dump zone to <file>" message when writing to stdout. [RT #27109]
- 3258. [test] Add "forcing full sign with unreadable keys" test. [RT #27153]
- 3257. [bug] Do not generate a error message when calling fsync() in a pipe or socket. [RT #27109]
- 3256. [bug] Disable empty zones for lwresd -C. [RT #27139]

(continues on next page)

(continued from previous page)

- 3255. [func] No longer require that a empty zones be explicitly enabled or that a empty zone is disabled for RFC 1918 empty zones to be configured. [RT #27139]
- 3254. [bug] Set `isc_socket_ipv6only()` on the IPv6 control channels. [RT #22249]
- 3253. [bug] Return `DNS_R_SYNTAX` when the input to a text field is too long. [RT #26956]
- 3252. [bug] When master zones using inline-signing were updated while the server was offline, the source zone could fall out of sync with the signed copy. They can now resynchronize. [RT #26676]
- 3251. [bug] Enforce a upper bound (65535 bytes) on the amount of memory `dns_sdlz_putrr()` can allocate per record to prevent run away memory consumption on `ISC_R_NOSPACE`. [RT #26956]
- 3250. [func] 'configure --enable-developer'; turn on various configure options, normally off by default, that we want developers to build and test with. [RT #27103]
- 3249. [bug] Update log message when saving slave zones files for analysis after load failures. [RT #27087]
- 3248. [bug] Configure options `--enable-fixed-rrset` and `--enable-exportlib` were incompatible with each other. [RT #27087]
- 3247. [bug] 'raw' format zones failed to preserve load order breaking 'fixed' sort order. [RT #27087]
- 3246. [bug] Named failed to start with a empty also-notify list. [RT #27087]
- 3245. [bug] Don't report a error unchanged serials unless there were other changes when thawing a zone with `ixfr-fromdifferences`. [RT #26845]
- 3244. [func] Added readline support to `nslookup` and `nsupdate`. Also simplified `nsupdate` syntax to make "update" and "prereq" optional. [RT #24659]
- 3243. [port] `freebsd,netbsd,bsd`: the thread defaults were not being properly set.
- 3242. [func] Extended the header of raw-format master files to include the serial number of the zone from which they were generated, if different (as in the case

(continues on next page)

(continued from previous page)

		of inline-signing zones). This is to be used in inline-signing zones, to track changes between the unsigned and signed versions of the zone, which may have different serial numbers.
		(Note: raw zonefiles generated by this version of BIND are no longer compatible with prior versions. To generate a backward-compatible raw zonefile using <code>dnssec-signzone</code> or <code>named-compilezone</code> , specify output format <code>"raw=0"</code> instead of simply <code>"raw"</code> .) [RT #26587]
3241.	[bug]	Address race conditions in the resolver code. [RT #26889]
3240.	[bug]	DNSKEY state change events could be missed. [RT #26874]
3239.	[bug]	<code>dns_dnssec_findmatchingkeys</code> needs to use a consistent timestamp. [RT #26883]
3238.	[bug]	<code>keyrdata</code> was not being reinitialized in <code>lib/dns/rbtdb.c:iszonesecure</code> . [RT #26913]
3237.	[bug]	<code>dig -6</code> didn't work with <code>+trace</code> . [RT #26906]
3236.	[bug]	Backed out changes #3182 and #3202, related to EDNS(0) fallback behavior. [RT #26416]
3235.	[func]	<code>dns_db_diffx</code> , a extended <code>dns_db_diff</code> which returns the generated diff and optionally writes it to a journal. [RT #26386]
3234.	[bug]	'make depend' produced invalid makefiles. [RT #26830]
3233.	[bug]	'rndc freeze/thaw' didn't work for inline zones. [RT #26632]
3232.	[bug]	Zero zone->curmaster before return in <code>dns_zone_setmasterswithkeys()</code> . [RT #26732]
3231.	[bug]	<code>named</code> could fail to send a incompressible zone. [RT #26796]
3230.	[bug]	'dig axfr' failed to properly handle a multi-message axfr with a serial of 0. [RT #26796]
3229.	[bug]	Fix local variable to struct var assignment found by CLANG warning.
3228.	[tuning]	Dynamically grow symbol table to improve zone loading performance. [RT #26523]

(continues on next page)

(continued from previous page)

- 3227. [bug] Interim fix to make WKS's use of getprotobyname() and getservbyname() self thread safe. [RT #26232]
- 3226. [bug] Address minor resource leakages. [RT #26624]
- 3225. [bug] Silence spurious "setsockopt(517, IPV6\_V6ONLY) failed" messages. [RT #26507]
- 3224. [bug] 'rndc signing' argument parsing was broken. [RT #26684]
- 3223. [bug] 'task\_test privilege\_drop' generated false positives. [RT #26766]
- 3222. [cleanup] Replace dns\_journal\_{get,set}\_bitws with dns\_journal\_{get,set}\_sourceserial. [RT #26634]
- 3221. [bug] Fixed a potential core dump on shutdown due to referencing fetch context after it's been freed. [RT #26720]

--- 9.9.0b2 released ---

- 3220. [bug] Change #3186 was incomplete; dns\_db\_rpz\_findips() could fail to set the database version correctly, causing an assertion failure. [RT #26180]
- 3219. [bug] Disable NOEDNS caching following a timeout.
- 3218. [security] Cache lookup could return RRSIG data associated with nonexistent records, leading to an assertion failure. [RT #26590]
- 3217. [cleanup] Fix build problem with --disable-static. [RT #26476]
- 3216. [bug] resolver.c:validated() was not thread-safe. [RT #26478]
- 3215. [bug] 'rndc recursing' could cause a core dump. [RT #26495]
- 3214. [func] Add 'named -U' option to set the number of UDP listener threads per interface. [RT #26485]
- 3213. [doc] Clarify ixfr-from-differences behavior. [RT #25188]
- 3212. [bug] rbtodb.c: failed to remove a node from the deadnodes list prior to adding a reference to it leading a possible assertion failure. [RT #23219]
- 3211. [func] dnssec-signzone: "-f -" prints to stdout; "-O full" option prints in single-line-per-record format. [RT #20287]
- 3210. [bug] Canceling the oldest query due to recursive-client

(continues on next page)

(continued from previous page)

		overload could trigger an assertion failure. [RT #26463]
3209.	[func]	Add "dnssec-lookaside 'no'". [RT #24858]
3208.	[bug]	'dig -y' handle unknown tsig algorithm better. [RT #25522]
3207.	[contrib]	Fixed build error in Berkeley DB DLZ module. [RT #26444]
3206.	[cleanup]	Add ISC information to log at start time. [RT #25484]
3205.	[func]	Upgrade dig's defaults to better reflect modern nameserver behavior. Enable "dig +adflag" and "dig +edns=0" by default. Enable "+dnssec" when running "dig +trace". [RT #23497]
3204.	[bug]	When a master server that has been marked as unreachable sends a NOTIFY, mark it reachable again. [RT #25960]
3203.	[bug]	Increase log level to 'info' for validation failures from expired or not-yet-valid RRSIGs. [RT #21796]
3202.	[bug]	NOEDNS caching on timeout was too aggressive. [RT #26416]
3201.	[func]	'rndc querylog' can now be given an on/off parameter instead of only being used as a toggle. [RT #18351]
3200.	[doc]	Some rndc functions were undocumented or were missing from 'rndc -h' output. [RT #25555]
3199.	[func]	When logging client information, include the name being queried. [RT #25944]
3198.	[doc]	Clarified that dnssec-settime can alter keyfile permissions. [RT #24866]
3197.	[bug]	Don't try to log the filename and line number when the config parser can't open a file. [RT #22263]
3196.	[bug]	nsupdate: return nonzero exit code when target zone doesn't exist. [RT #25783]
3195.	[cleanup]	Silence "file not found" warnings when loading managed-keys zone. [RT #26340]
3194.	[doc]	Updated RFC references in the 'empty-zones-enable' documentation. [RT #25203]
3193.	[cleanup]	Changed MAXZONEKEYS to DNS_MAXZONEKEYS, moved to dnssec.h. [RT #26415]

(continues on next page)

(continued from previous page)

- 3192. [bug] A query structure could be used after being freed.  
[RT #22208]
- 3191. [bug] Print NULL records using "unknown" format. [RT #26392]
- 3190. [bug] Underflow in error handling in isc\_mutexblock\_init.  
[RT #26397]
- 3189. [test] Added a summary report after system tests. [RT #25517]
- 3188. [bug] zone.c:zone\_refreshkeys() could fail to detach  
references correctly when errors occurred, causing  
a hang on shutdown. [RT #26372]
- 3187. [port] win32: support for Visual Studio 2008. [RT #26356]

--- 9.9.0b1 released ---

- 3186. [bug] Version/db mismatch in rpz code. [RT #26180]
- 3185. [func] New 'rndc signing' option for auto-dnssec zones:
  - 'rndc signing -list' displays the current  
state of signing operations
  - 'rndc signing -clear' clears the signing state  
records for keys that have fully signed the zone
  - 'rndc signing -nsec3param' sets the NSEC3  
parameters for the zone
 The 'rndc keydone' syntax is removed. [RT #23729]
- 3184. [bug] named had excessive cpu usage when a redirect zone was  
configured. [RT #26013]
- 3183. [bug] Added RTLD\_GLOBAL flag to dlopen call. [RT #26301]
- 3182. [bug] Auth servers behind firewalls which block packets  
greater than 512 bytes may cause other servers to  
perform poorly. Now, adb retains edns information  
and caches noedns servers. [RT #23392/24964]
- 3181. [func] Inline-signing is now supported for master zones.  
[RT #26224]
- 3180. [func] Local copies of slave zones are now saved in raw  
format by default, to improve startup performance.  
'masterfile-format text;' can be used to override  
the default, if desired. [RT #25867]
- 3179. [port] kfreebsd: build issues. [RT #26273]
- 3178. [bug] A race condition introduced by change #3163 could  
cause an assertion failure on shutdown. [RT #26271]

(continues on next page)

(continued from previous page)

- 3177. [func] 'rndc keydone', remove the indicator record that named has finished signing the zone with the corresponding key. [RT #26206]
- 3176. [doc] Corrected example code and added a README to the sample external DLZ module in contrib/dlz/example. [RT #26215]
- 3175. [bug] Fix how DNSSEC positive wildcard responses from a NSEC3 signed zone are validated. Stop sending a unnecessary NSEC3 record when generating such responses. [RT #26200]
- 3174. [bug] Always compute to revoked key tag from scratch. [RT #26186]
- 3173. [port] Correctly validate root DS responses. [RT #25726]
- 3172. [port] darwin 10.\* and freebsd [89] are now built threaded by default.
- 3171. [bug] Exclusively lock the task when adding a zone using 'rndc addzone'. [RT #25600]

--- 9.9.0a3 released ---

- 3170. [func] RPZ update:
  - fix precedence among competing rules
  - improve ARM text including documenting rule precedence
  - try to rewrite CNAME chains until first hit
  - new "rpz" logging channel
  - RDATA for CNAME rules can include wildcards
  - replace "NO-OP" named.conf policy override with "PASSTHRU" and add "DISABLED" override ("NO-OP" is still recognized)
 [RT #25172]
- 3169. [func] Catch db/version mis-matches when calling dns\_db\_\*(). [RT #26017]
- 3168. [bug] Nxdomain redirection could trigger an assert with a ANY query. [RT #26017]
- 3167. [bug] Negative answers from forwarders were not being correctly tagged making them appear to not be cached. [RT #25380]
- 3166. [bug] Upgrading a zone to support inline-signing failed. [RT #26014]
- 3165. [bug] dnssec-signzone could generate new signatures when

(continues on next page)

(continued from previous page)

		resigning, even when valid signatures were already present. [RT #26025]
3164.	[func]	Enable DLZ modules to retrieve client information, so that responses can be changed depending on the source address of the query. [RT #25768]
3163.	[bug]	Use finer-grained locking in client.c to address concurrency problems with large numbers of threads. [RT #26044]
3162.	[test]	start.pl: modified to allow for "named.args" in ns*/ subdirectory to override stock arguments to named. Largely from RT #26044, but no separate ticket.
3161.	[bug]	zone.c:del_sigs failed to always reset rdata leading assertion failures. [RT #25880]
3160.	[bug]	When printing out a NSEC3 record in multiline form the newline was not being printed causing type codes to be run together. [RT #25873]
3159.	[bug]	On some platforms, named could assert on startup when running in a chrooted environment without /proc. [RT #25863]
3158.	[bug]	Recursive servers would prefer a particular UDP socket instead of using all available sockets. [RT #26038]
3157.	[tuning]	Reduce the time spent in "rndc reconfig" by parsing the config file before pausing the server. [RT #21373]
3156.	[placeholder]	

		--- 9.9.0a2 released ---
3155.	[bug]	Fixed a build failure when using contrib DLZ drivers (e.g., mysql, postgresql, etc). [RT #25710]
3154.	[bug]	Attempting to print an empty rdataset could trigger an assert. [RT #25452]
3153.	[func]	Extend request-ixfr to zone level and remove the side effect of forcing an AXFR. [RT #25156]
3152.	[cleanup]	Some versions of gcc and clang failed due to incorrect use of __builtin_expect. [RT #25183]
3151.	[bug]	Queries for type RRSIG or SIG could be handled incorrectly. [RT #21050]

(continues on next page)

(continued from previous page)

3150.	[func]	Improved startup and reconfiguration time by enabling zones to load in multiple threads. [RT #25333]
3149.	[placeholder]	
3148.	[bug]	Processing of normal queries could be stalled when forwarding a UPDATE message. [RT #24711]
3147.	[func]	Initial inline signing support. [RT #23657]

--- 9.9.0a1 released ---		
3146.	[test]	Fixed gcc4.6.0 errors in ATF. [RT #25598]
3145.	[test]	Capture output of ATF unit tests in "./atf.out" if there were any errors while running them. [RT #25527]
3144.	[bug]	dns_dbiterator_seek() could trigger an assert when used with a nonexistent database node. [RT #25358]
3143.	[bug]	Silence clang compiler warnings. [RT #25174]
3142.	[bug]	NAPTR is class agnostic. [RT #25429]
3141.	[bug]	Silence spurious "zone serial (0) unchanged" messages associated with empty zones. [RT #25079]
3140.	[func]	New command "rndc flushtree <name>" clears the specified name from the server cache along with all names under it. [RT #19970]
3139.	[test]	Added tests from RFC 6234, RFC 2202, and RFC 1321 for the hashing algorithms (md5, sha1 - sha512, and their hmac counterparts). [RT #25067]
3138.	[bug]	Address memory leaks and out-of-order operations when shutting named down. [RT #25210]
3137.	[func]	Improve hardware scalability by allowing multiple worker threads to process incoming UDP packets. This can significantly increase query throughput on some systems. [RT #22992]
3136.	[func]	Add RFC 1918 reverse zones to the list of built-in empty zones switched on by the 'empty-zones-enable' option. [RT #24990]
3135.	[port]	FreeBSD: workaround broken IPV6_USE_MIN_MTU processing. See <a href="http://www.freebsd.org/cgi/query-pr.cgi?pr=158307">http://www.freebsd.org/cgi/query-pr.cgi?pr=158307</a> [RT #24950]
3134.	[bug]	Improve the accuracy of dnssec-signzone's signing

(continues on next page)

(continued from previous page)

		statistics. [RT #16030]
3133.	[bug]	Change #3114 was incomplete. [RT #24577]
3132.	[placeholder]	
3131.	[tuning]	Improve scalability by allocating one zone task per 100 zones at startup time, rather than using a fixed-size task table. [RT #24406]
3130.	[func]	Support alternate methods for managing a dynamic zone's serial number. Two methods are currently defined using serial-update-method, "increment" (default) and "unixtime". [RT #23849]
3129.	[bug]	Named could crash on 'rndc reconfig' when allow-new-zones was set to yes and named ACLs were used. [RT #22739]
3128.	[func]	Inserting an NSEC3PARAM via dynamic update in an auto-dnssec zone that has not been signed yet will cause it to be signed with the specified NSEC3 parameters when keys are activated. The NSEC3PARAM record will not appear in the zone until it is signed, but the parameters will be stored. [RT #23684]
3127.	[bug]	'rndc thaw' will now remove a zone's journal file if the zone serial number has been changed and ixfr-from-differences is not in use. [RT #24687]
3126.	[security]	Using DNAME record to generate replacements caused RPZ to exit with a assertion failure. [RT #24766]
3125.	[security]	Using wildcard CNAME records as a replacement with RPZ caused named to exit with a assertion failure. [RT #24715]
3124.	[bug]	Use an rdataset attribute flag to indicate negative-cache records rather than using rrtype 0; this will prevent problems when that rrtype is used in actual DNS packets. [RT #24777]
3123.	[security]	Change #2912 exposed a latent flaw in dns_rdataset_totext() that could cause named to crash with an assertion failure. [RT #24777]
3122.	[cleanup]	dnssec-settime: corrected usage message. [RT #24664]
3121.	[security]	An authoritative name server sending a negative response containing a very large RRset could trigger an off-by-one error in the ncache code

(continues on next page)

(continued from previous page)

		and crash named. [RT #24650]
3120.	[bug]	Named could fail to validate zones listed in a DLV that validated insecure without using DLV and had DS records in the parent zone. [RT #24631]
3119.	[bug]	When rolling to a new DNSSEC key, a private-type record could be created and never marked complete. [RT #23253]
3118.	[bug]	nsupdate could dump core on shutdown when using SIG(0) keys. [RT #24604]
3117.	[cleanup]	Remove doc and parser references to the never-implemented 'auto-dnssec create' option. [RT #24533]
3116.	[func]	New 'dnssec-update-mode' option controls updates of DNSSEC records in signed dynamic zones. Set to 'no-resign' to disable automatic RRSIG regeneration while retaining the ability to sign new or changed data. [RT #24533]
3115.	[bug]	Named could fail to return requested data when following a CNAME that points into the same zone. [RT #24455]
3114.	[bug]	Retain expired RRSIGs in dynamic zones if key is inactive and there is no replacement key. [RT #23136]
3113.	[doc]	Document the relationship between serial-query-rate and NOTIFY messages.
3112.	[doc]	Add missing descriptions of the update policy name types "ms-self", "ms-subdomain", "krb5-self" and "krb5-subdomain", which allow machines to update their own records, to the BIND 9 ARM.
3111.	[bug]	Improved consistency checks for dnssec-enable and dnssec-validation, added test cases to the checkconf system test. [RT #24398]
3110.	[bug]	dnssec-signzone: Wrong error message could appear when attempting to sign with no KSK. [RT #24369]
3109.	[func]	The also-notify option now uses the same syntax as a zone's masters clause. This means it is now possible to specify a TSIG key to use when sending notifies to a given server, or to include an explicit named masters list in an also-notify statement. [RT #23508]

(continues on next page)

(continued from previous page)

- 3108. [cleanup] dnssec-signzone: Clarified some error and warning messages; removed #ifdef ALLOW\_KSKLESS\_ZONES code (use -P instead). [RT #20852]
- 3107. [bug] dnssec-signzone: Report the correct number of ZSKs when using -x. [RT #20852]
- 3106. [func] When logging client requests, include the name of the TSIG key if any. [RT #23619]
- 3105. [bug] GOST support can be suppressed by "configure --without-gost" [RT #24367]
- 3104. [bug] Better support for cross-compiling. [RT #24367]
- 3103. [bug] Configuring 'dnssec-validation auto' in a view instead of in the options statement could trigger an assertion failure in named-checkconf. [RT #24382]
- 3102. [func] New 'dnssec-loadkeys-interval' option configures how often, in minutes, to check the key repository for updates when using automatic key maintenance. Default is every 60 minutes (formerly hard-coded to 12 hours). [RT #23744]
- 3101. [bug] Zones using automatic key maintenance could fail to check the key repository for updates. [RT #23744]
- 3100. [security] Certain response policy zone configurations could trigger an INSIST when receiving a query of type RRSIG. [RT #24280]
- 3099. [test] "dlz" system test now runs but gives R:SKIPPED if not compiled with --with-dlz-filesystem. [RT #24146]
- 3098. [bug] DLZ zones were answering without setting the AA bit. [RT #24146]
- 3097. [test] Add a tool to test handling of malformed packets. [RT #24096]
- 3096. [bug] Set KRB5\_KTNAME before calling log\_cred() in dst\_gssapi\_acceptctx(). [RT #24004]
- 3095. [bug] Handle isolated reserved ports in the port range. [RT #23957]
- 3094. [doc] Expand dns64 documentation.
- 3093. [bug] Fix gssapi/kerberos dependencies [RT #23836]
- 3092. [bug] Signatures for records at the zone apex could go

(continues on next page)

(continued from previous page)

- stale due to an incorrect timer setting. [RT #23769]

3091. [bug] Fixed a bug in which zone keys that were published and then subsequently activated could fail to trigger automatic signing. [RT #22911]
- 3090. [func] Make --with-gssapi default [RT #23738]
- 3089. [func] dnssec-dsfromkey now supports reading keys from standard input "dnssec-dsfromkey -f -". [RT #20662]
- 3088. [bug] Remove bin/tests/system/logfileconfig/ns1/named.conf and add setup.sh in order to resolve changing named.conf issue. [RT #23687]
- 3087. [bug] DDNS updates using SIG(0) with update-policy match type "external" could cause a crash. [RT #23735]
- 3086. [bug] Running dnssec-settime -f on an old-style key will now force an update to the new key format even if no other change has been specified, using "-P now -A now" as default values. [RT #22474]
- 3085. [func] New '-R' option in dnssec-signzone forces removal of signatures which have not yet expired but were generated by a key that no longer exists. [RT #22471]
- 3084. [func] A new command "rndc sync" dumps pending changes in a dynamic zone to disk; "rndc sync -clean" also removes the journal file after syncing. Also, "rndc freeze" no longer removes journal files. [RT #22473]
- 3083. [bug] NOTIFY messages were not being sent when generating a NSEC3 chain incrementally. [RT #23702]
- 3082. [port] strtok\_r is threads only. [RT #23747]
- 3081. [bug] Failure of DNAME substitution did not return YXDOMAIN. [RT #23591]
- 3080. [cleanup] Replaced compile time constant by STDTIME\_ON\_32BITS. [RT #23587]
- 3079. [bug] Handle isc\_event\_allocate failures in t\_tasks. [RT #23572]
- 3078. [func] Added a new include file with function typedefs for the DLZ "dlopen" driver. [RT #23629]
- 3077. [bug] zone.c:zone\_refreshkeys() incorrectly called

(continues on next page)

(continued from previous page)

		dns_zone_attach(), use zone->irefs instead. [RT #23303]
3076.	[func]	New '-L' option in dnssec-keygen, dnsset-settime, and dnssec-keyfromlabel sets the default TTL of the key. When possible, automatic signing will use that TTL when the key is published. [RT #23304]
3075.	[bug]	dns_dnssec_findzonekeys{2} used a inconsistent timestamp when determining which keys are active. [RT #23642]
3074.	[bug]	Make the adb cache read through for zone data and glue learn for zone named is authoritative for. [RT #22842]
3073.	[bug]	managed-keys changes were not properly being recorded. [RT #20256]
3072.	[bug]	dns_dns64_aaaaok() potential NULL pointer dereference. [RT #20256]
3071.	[bug]	has_nsec could be used uninitialized in update.c:next_active. [RT #20256]
3070.	[bug]	dnssec-signzone potential NULL pointer dereference. [RT #20256]
3069.	[cleanup]	Silence warnings messages from clang static analysis. [RT #20256]
3068.	[bug]	Named failed to build with a OpenSSL without engine support. [RT #23473]
3067.	[bug]	ixfr-from-differences {master slave}; failed to select the master/slave zones. [RT #23580]
3066.	[func]	The DLZ "dlopen" driver is now built by default, no longer requiring a configure option. To disable it, use "configure --without-dlopen". Driver also supported on win32. [RT #23467]
3065.	[bug]	RRSIG could have time stamps too far in the future. [RT #23356]
3064.	[bug]	powerpc: add sync instructions to the end of atomic operations. [RT #23469]
3063.	[contrib]	More verbose error reporting from DLZ LDAP. [RT #23402]
3062.	[func]	Made several changes to enhance human readability of DNSSEC data in dig output and in generated zone files:

(continues on next page)

(continued from previous page)

- DNSKEY record comments are more verbose, no longer used in multiline mode only

- multiline RRSIG records reformatted

- multiline output mode for NSEC3PARAM records

- "dig +norrcomments" suppresses DNSKEY comments

- "dig +split=X" breaks hex/base64 records into fields of width X; "dig +nosplit" disables this.

[RT #22820]
- 3061. [func] New option "dnssec-signzone -D", only write out generated DNSSEC records. [RT #22896]
- 3060. [func] New option "dnssec-signzone -X <date>" allows specification of a separate expiration date for DNSKEY RRSIGs and other RRSIGs. [RT #22141]
- 3059. [test] Added a regression test for change #3023.
- 3058. [bug] Cause named to terminate at startup or rndc reconfig/reload to fail, if a log file specified in the conf file isn't a plain file. [RT #22771]
- 3057. [bug] "rndc secroots" would abort after the first error and so could miss some views. [RT #23488]
- 3056. [func] Added support for URI resource record. [RT #23386]
- 3055. [placeholder]
- 3054. [bug] Added elliptic curve support check in GOST OpenSSL engine detection. [RT #23485]
- 3053. [bug] Under a sustained high query load with a finite max-cache-size, it was possible for cache memory to be exhausted and not recovered. [RT #23371]
- 3052. [test] Fixed last autosign test report. [RT #23256]
- 3051. [bug] NS records obscure DNAME records at the bottom of the zone if both are present. [RT #23035]
- 3050. [bug] The autosign system test was timing dependent. Wait for the initial autosigning to complete before running the rest of the test. [RT #23035]
- 3049. [bug] Save and restore the gid when creating creating named.pid at startup. [RT #23290]
- 3048. [bug] Fully separate view key management. [RT #23419]
- 3047. [bug] DNSKEY NODATA responses not cached fixed in validator.c. Tests added to dnssec system test.

(continues on next page)

(continued from previous page)

		[RT #22908]
3046.	[bug]	Use RRSIG original TTL to compute validated RRset and RRSIG TTL. [RT #23332]
3045.	[removed]	Replaced by change #3050.
3044.	[bug]	Hold the socket manager lock while freeing the socket. [RT #23333]
3043.	[test]	Merged in the NetBSD ATF test framework (currently version 0.12) for development of future unit tests. Use configure --with-atf to build ATF internally or configure --with-atf=prefix to use an external copy. [RT #23209]
3042.	[bug]	dig +trace could fail attempting to use IPv6 addresses on systems with only IPv4 connectivity. [RT #23297]
3041.	[bug]	dnssec-signzone failed to generate new signatures on ttl changes. [RT #23330]
3040.	[bug]	Named failed to validate insecure zones where a node with a CNAME existed between the trust anchor and the top of the zone. [RT #23338]
3039.	[func]	Redirect on NXDOMAIN support. [RT #23146]
3038.	[bug]	Install <dns/rpz.h>. [RT #23342]
3037.	[doc]	Update COPYRIGHT to contain all the individual copyright notices that cover various parts.
3036.	[bug]	Check built-in zone arguments to see if the zone is re-usable or not. [RT #21914]
3035.	[cleanup]	Simplify by using strlcpy. [RT #22521]
3034.	[cleanup]	nslookup: use strlcpy instead of safecopy. [RT #22521]
3033.	[cleanup]	Add two INSIST(bucket != DNS_ADB_INVALIDBUCKET). [RT #22521]
3032.	[bug]	rdatalist.c: add missing REQUIRES. [RT #22521]
3031.	[bug]	dns_rdataclass_format() handle a zero sized buffer. [RT #22521]
3030.	[bug]	dns_rdatatype_format() handle a zero sized buffer. [RT #22521]

(continues on next page)

(continued from previous page)

- 3029. [bug] isc\_netaddr\_format() handle a zero sized buffer.  
[RT #22521]
- 3028. [bug] isc\_sockaddr\_format() handle a zero sized buffer.  
[RT #22521]
- 3027. [bug] Add documented REQUIRES to cfg\_obj\_asnetprefix() to  
catch NULL pointer dereferences before they happen.  
[RT #22521]
- 3026. [bug] lib/isc/httpd.c: check that we have enough space  
after calling grow\_headerspace() and if not  
re-call grow\_headerspace() until we do. [RT #22521]
- 3025. [bug] Fixed a possible deadlock due to zone resigning.  
[RT #22964]
- 3024. [func] RTT Banding removed due to minor security increase  
but major impact on resolver latency. [RT #23310]
- 3023. [bug] Named could be left in an inconsistent state when  
receiving multiple AXFR response messages that were  
not all TSIG-signed. [RT #23254]
- 3022. [bug] Fixed rpz SERVFAILs after failed zone transfers  
[RT #23246]
- 3021. [bug] Change #3010 was incomplete. [RT #22296]
- 3020. [bug] auto-dnssec failed to correctly update the zone when  
changing the DNSKEY RRset. [RT #23232]
- 3019. [test] Test: check apex NSEC3 records after adding DNSKEY  
record via UPDATE. [RT #23229]
- 3018. [bug] Named failed to check for the "none;" acl when deciding  
if a zone may need to be re-signed. [RT #23120]
- 3017. [doc] dnssec-keyfromlabel -I was not properly documented.  
[RT #22887]
- 3016. [bug] rndc usage missing '-b'. [RT #22937]
- 3015. [port] win32: fix IN6\_IS\_ADDR\_LINKLOCAL and  
IN6\_IS\_ADDR\_SITELOCAL macros. [RT #22724]
- 3014. [placeholder]
- 3013. [bug] The DNS64 ttl was not always being set as expected.  
[RT #23034]
- 3012. [bug] Remove DNSKEY TTL change pairs before generating

(continues on next page)

(continued from previous page)

		signing records for any remaining DNSKEY changes. [RT #22590]
3011.	[func]	Change the default query timeout from 30 seconds to 10. Allow setting this in named.conf using the new 'resolver-query-timeout' option, which specifies a max time in seconds. 0 means 'default' and anything longer than 30 will be silently set to 30. [RT #22852]
3010.	[bug]	Fixed a bug where "rndc reconfig" stopped the timer for refreshing managed-keys. [RT #22296]
3009.	[bug]	clients-per-query code didn't work as expected with particular query patterns. [RT #22972]

		--- 9.8.0b1 released ---
3008.	[func]	Response policy zones (RPZ) support. [RT #21726]
3007.	[bug]	Named failed to preserve the case of domain names in rdata which is not compressible when writing master files. [RT #22863]
3006.	[func]	Allow dynamically generated TSIG keys to be preserved across restarts of named. Initially this is for TSIG keys generated using GSSAPI. [RT #22639]
3005.	[port]	Solaris: Work around the lack of gsskrb5_register_acceptor_identity() by setting the KRB5_KTNAME environment variable to the contents of tkey-gssapi-keytab. Also fixed test errors on MacOSX. [RT #22853]
3004.	[func]	DNS64 reverse support. [RT #22769]
3003.	[experimental]	Added update-policy match type "external", enabling named to defer the decision of whether to allow a dynamic update to an external daemon. (Contributed by Andrew Tridgell.) [RT #22758]
3002.	[bug]	isc_mutex_init_errcheck() failed to destroy attr. [RT #22766]
3001.	[func]	Added a default trust anchor for the root zone, which can be switched on by setting "dnssec-validation auto;" in the named.conf options. [RT #21727]
3000.	[bug]	More TKEY/GSS fixes: <ul style="list-style-type: none"> <li>- nsupdate can now get the default realm from the user's Kerberos principal</li> <li>- corrected gsstest compilation flags</li> <li>- improved documentation</li> </ul>

(continues on next page)

(continued from previous page)

- fixed some NULL dereferences  
[RT #22795]
- 2999. [func] Add GOST support (RFC 5933). [RT #20639]
- 2998. [func] Add `isc_task_beginexclusive` and `isc_task_endexclusive` to the task api. [RT #22776]
- 2997. [func] `named -V` now reports the OpenSSL and libxml2 versions it was compiled against. [RT #22687]
- 2996. [security] Temporarily disable `SO_ACCEPTFILTER` support. [RT #22589]
- 2995. [bug] The Kerberos realm was not being correctly extracted from the signer's identity. [RT #22770]
- 2994. [port] NetBSD: use `pthread`s by default on NetBSD  $\geq$  5.0, and do not use threads on earlier versions. Also kill the `unproven-pthreads`, `mit-pthreads`, and `ptl2` support.
- 2993. [func] Dynamically grow `adb` hash tables. [RT #21186]
- 2992. [contrib] `contrib/check-secure-delegation.pl`: A simple tool for looking at a secure delegation. [RT #22059]
- 2991. [contrib] `contrib/zone-edit.sh`: A simple zone editing tool for dynamic zones. [RT #22365]
- 2990. [bug] `'dnstsec-settime -S'` no longer tests prepublication interval validity when the interval is set to 0. [RT #22761]
- 2989. [func] Added support for writable DLZ zones. (Contributed by Andrew Tridgell of the Samba project.) [RT #22629]
- 2988. [experimental] Added a `"dlopen"` DLZ driver, allowing the creation of external DLZ drivers that can be loaded as shared objects at runtime rather than linked with `named`. Currently this is switched on via a compile-time option, `"configure --with-dlz-dlopen"`. Note: the syntax for configuring DLZ zones is likely to be refined in future releases. (Contributed by Andrew Tridgell of the Samba project.) [RT #22629]
- 2987. [func] Improve ease of configuring TKEY/GSS updates by adding a `"tkey-gssapi-keytab"` option. If set, updates will be allowed with any key matching a principal in the specified keytab file. `"tkey-gssapi-credential"` is no longer required and is expected to be deprecated. (Contributed

(continues on next page)

(continued from previous page)

		by Andrew Tridgell of the Samba project.) [RT #22629]
2986.	[func]	Add new zone type "static-stub". It's like a stub zone, but the nameserver names and/or their IP addresses are statically configured. [RT #21474]
2985.	[bug]	Add a regression test for change #2896. [RT #21324]
2984.	[bug]	Don't run MX checks when the target of the MX record is ".". [RT #22645]
2983.	[bug]	Include "loadkeys" in rndc help output. [RT #22493]

		--- 9.8.0a1 released ---
2982.	[bug]	Reference count dst keys. dst_key_attach() can be used increment the reference count.  Note: dns_tsigkey_createfromkey() callers should now always call dst_key_free() rather than setting it to NULL on success. [RT #22672]
2981.	[func]	Partial DNS64 support (AAAA synthesis). [RT #21991]
2980.	[bug]	named didn't properly handle UPDATES that changed the TTL of the NSEC3PARAM RRset. [RT #22363]
2979.	[bug]	named could deadlock during shutdown if two "rndc stop" commands were issued at the same time. [RT #22108]
2978.	[port]	hpux: look for <devpoll.h> [RT #21919]
2977.	[bug]	'nsupdate -l' report if the session key is missing. [RT #21670]
2976.	[bug]	named could die on exit after negotiating a GSS-TSIG key. [RT #22573]
2975.	[bug]	rbtdb.c:cleanup_dead_nodes_callback() acquired the wrong lock which could lead to server deadlock. [RT #22614]
2974.	[bug]	Some valid UPDATE requests could fail due to a consistency check examining the existing version of the zone rather than the new version resulting from the UPDATE. [RT #22413]
2973.	[bug]	bind.keys.h was being removed by the "make clean" at the end of configure resulting in build failures where there is very old version of perl installed.

(continues on next page)

(continued from previous page)

		Move it to "make maintainer-clean". [RT #22230]
2972.	[bug]	win32: address windows socket errors. [RT #21906]
2971.	[bug]	Fixed a bug that caused journal files not to be compacted on Windows systems as a result of non-POSIX-compliant rename() semantics. [RT #22434]
2970.	[security]	Adding a NO DATA negative cache entry failed to clear any matching RRSIG records. A subsequent lookup of of NO DATA cache entry could trigger a INSIST when the unexpected RRSIG was also returned with the NO DATA cache entry.  CVE-2010-3613, VU#706148. [RT #22288]
2969.	[security]	Fix acl type processing so that allow-query works in options and view statements. Also add a new set of tests to verify proper functioning.  CVE-2010-3615, VU#510208. [RT #22418]
2968.	[security]	Named could fail to prove a data set was insecure before marking it as insecure. One set of conditions that can trigger this occurs naturally when rolling DNSKEY algorithms.  CVE-2010-3614, VU#837744. [RT #22309]
2967.	[bug]	'host -D' now turns on debugging messages earlier. [RT #22361]
2966.	[bug]	isc_print_vsnprintf() failed to check if there was space available in the buffer when adding a left justified character with a non zero width, (e.g. "%-1c"). [RT #22270]
2965.	[func]	Test HMAC functions using test data from RFC 2104 and RFC 4634. [RT #21702]
2964.	[placeholder]	
2963.	[security]	The allow-query acl was being applied instead of the allow-query-cache acl to cache lookups. [RT #22114]
2962.	[port]	win32: add more dependencies to BINDBuild.dsw. [RT #22062]
2961.	[bug]	Be still more selective about the non-authoritative answers we apply change 2748 to. [RT #22074]
2960.	[func]	Check that named accepts non-authoritative answers.

(continues on next page)

(continued from previous page)

		[RT #21594]
2959.	[func]	Check that named starts with a missing masterfile. [RT #22076]
2958.	[bug]	named failed to start with a missing master file. [RT #22076]
2957.	[bug]	entropy_get() and entropy_getpseudo() failed to match the API for RAND_bytes() and RAND_pseudo_bytes() respectively. [RT #21962]
2956.	[port]	Enable atomic operations on the PowerPC64. [RT #21899]
2955.	[func]	Provide more detail in the recursing log. [RT #22043]
2954.	[bug]	contrib: dlz_mysql_driver.c bad error handling on build_sqldbinstance failure. [RT #21623]
2953.	[bug]	Silence spurious "expected covering NSEC3, got an exact match" message when returning a wildcard no data response. [RT #21744]
2952.	[port]	win32: named-checkzone and named-checkconf failed to initialize winsock. [RT #21932]
2951.	[bug]	named failed to generate a correct signed response in a optout, delegation only zone with no secure delegations. [RT #22007]
2950.	[bug]	named failed to perform a SOA up to date check when falling back to TCP on UDP timeouts when ixfr-from-differences was set. [RT #21595]
2949.	[bug]	dns_view_setnewzones() contained a memory leak if it was called multiple times. [RT #21942]
2948.	[port]	MacOS: provide a mechanism to configure the test interfaces at reboot. See bin/tests/system/README for details.
2947.	[placeholder]	
2946.	[doc]	Document the default values for the minimum and maximum zone refresh and retry values in the ARM. [RT #21886]
2945.	[doc]	Update empty-zones list in ARM. [RT #21772]
2944.	[maint]	Remove ORCHID prefix from built in empty zones. [RT #21772]
2943.	[func]	Add support to load new keys into managed zones

(continues on next page)

(continued from previous page)

- without signing immediately with "rndc loadkeys".  
Add support to link keys with "dnssec-keygen -S"  
and "dnssec-settime -S". [RT #21351]
2942. [contrib] zone2sqlite failed to setup the entropy sources.  
[RT #21610]
2941. [bug] sdb and sdlz (dlz's zone database) failed to support  
DNNAME at the zone apex. [RT #21610]
2940. [port] Remove connection aborted error message on  
Windows. [RT #21549]
2939. [func] Check that named successfully skips NSEC3 records  
that fail to match the NSEC3PARAM record currently  
in use. [RT #21868]
2938. [bug] When generating signed responses, from a signed zone  
that uses NSEC3, named would use a uninitialized  
pointer if it needed to skip a NSEC3 record because  
it didn't match the selected NSEC3PARAM record for  
zone. [RT #21868]
2937. [bug] Worked around an apparent race condition in over  
memory conditions. Without this fix a DNS cache DB or  
ADB could incorrectly stay in an over memory state,  
effectively refusing further caching, which  
subsequently made a BIND 9 caching server unworkable.  
This fix prevents this problem from happening by  
polling the state of the memory context, rather than  
making a copy of the state, which appeared to cause  
a race. This is a "workaround" in that it doesn't  
solve the possible race per se, but several experiments  
proved this change solves the symptom. Also, the  
polling overhead hasn't been reported to be an issue.  
This bug should only affect a caching server that  
specifies a finite max-cache-size. It's also quite  
likely that the bug happens only when enabling threads,  
but it's not confirmed yet. [RT #21818]
2936. [func] Improved configuration syntax and multiple-view  
support for addzone/delzone feature (see change  
#2930). Removed "new-zone-file" option, replaced  
with "allow-new-zones (yes|no)". The new-zone-file  
for each view is now created automatically, with  
a filename generated from a hash of the view name.  
It is no longer necessary to "include" the  
new-zone-file in named.conf; this happens  
automatically. Zones that were not added via  
"rndc addzone" can no longer be removed with  
"rndc delzone". [RT #19447]

(continues on next page)

(continued from previous page)

- 2935. [bug] nsupdate: improve 'file not found' error message.  
[RT #21871]
- 2934. [bug] Use ANSI C compliant shift range in lib/isc/entropy.c.  
[RT #21871]
- 2933. [bug] 'dig +nsid' used stack memory after it went out of  
scope. This could potentially result in a unknown,  
potentially malformed, EDNS option being sent instead  
of the desired NSID option. [RT #21781]
- 2932. [cleanup] Corrected a numbering error in the "dnssec" test.  
[RT #21597]
- 2931. [bug] Temporarily and partially disable change 2864  
because it would cause infinite attempts of RRSIG  
queries. This is an urgent care fix; we'll  
revisit the issue and complete the fix later.  
[RT #21710]
- 2930. [experimental] New "rndc addzone" and "rndc delzone" commands  
allow dynamic addition and deletion of zones.  
To enable this feature, specify a "new-zone-file"  
option at the view or options level in named.conf.  
Zone configuration information for the new zones  
will be written into that file. To make the new  
zones persist after a restart, "include" the file  
into named.conf in the appropriate view. (Note:  
This feature is not yet documented, and its syntax  
is expected to change.) [RT #19447]
- 2929. [bug] Improved handling of GSS security contexts:
  - added LRU expiration for generated TSIGs
  - added the ability to use a non-default realm
  - added new "realm" keyword in nsupdate
  - limited lifetime of generated keys to 1 hour  
or the lifetime of the context (whichever is  
smaller)
 [RT #19737]
- 2928. [bug] Be more selective about the non-authoritative  
answer we apply change 2748 to. [RT #21594]
- 2927. [placeholder]
- 2926. [placeholder]
- 2925. [bug] Named failed to accept uncachable negative responses  
from insecure zones. [RT #21555]
- 2924. [func] 'rndc secroots' dump a combined summary of the  
current managed keys combined with trusted keys.

(continues on next page)

(continued from previous page)

		[RT #20904]
2923.	[bug]	'dig +trace' could drop core after "connection timeout". [RT #21514]
2922.	[contrib]	Update zkt to version 1.0.
2921.	[bug]	The resolver could attempt to destroy a fetch context too soon. [RT #19878]
2920.	[func]	Allow 'filter-aaaa-on-v4' to be applied selectively to IPv4 clients. New acl 'filter-aaaa' (default any).
2919.	[func]	Add autosign-ksk and autosign-zsk virtual time tests. [RT #20840]
2918.	[maint]	Add AAAA address for I.ROOT-SERVERS.NET.
2917.	[func]	Virtual time test framework. [RT #20801]
2916.	[func]	Add framework to use IPv6 in tests. fd92:7065:b8e:ffff::1 ... fd92:7065:b8e:ffff::7
2915.	[cleanup]	Be smarter about which objects we attempt to compile based on configure options. [RT #21444]
2914.	[bug]	Make the "autosign" system test more portable. [RT #20997]
2913.	[func]	Add pkcs#11 system tests. [RT #20784]
2912.	[func]	Windows clients don't like UPDATE responses that clear the zone section. [RT #20986]
2911.	[bug]	dnssec-signzone didn't handle out of zone records well. [RT #21367]
2910.	[func]	Sanity check Kerberos credentials. [RT #20986]
2909.	[bug]	named-checkconf -p could die if "update-policy local;" was specified in named.conf. [RT #21416]
2908.	[bug]	It was possible for re-signing to stop after removing a DNSKEY. [RT #21384]
2907.	[bug]	The export version of libdns had undefined references. [RT #21444]
2906.	[bug]	Address RFC 5011 implementation issues. [RT #20903]
2905.	[port]	aix: set use_atomic=yes with native compiler. [RT #21402]

(continues on next page)

(continued from previous page)

- 2904. [bug] When using DLV, sub-zones of the zones in the DLV, could be incorrectly marked as insecure instead of secure leading to negative proofs failing. This was a unintended outcome from change 2890. [RT #21392]
- 2903. [bug] managed-keys-directory missing from namedconf.c. [RT #21370]
- 2902. [func] Add regression test for change 2897. [RT #21040]
- 2901. [port] Use AC\_C\_FLEXIBLE\_ARRAY\_MEMBER. [RT #21316]
- 2900. [bug] The placeholder negative caching element was not properly constructed triggering a INSIST in dns\_ncache\_towire(). [RT #21346]
- 2899. [port] win32: Support linking against OpenSSL 1.0.0.
- 2898. [bug] nslookup leaked memory when -domain=value was specified. [RT #21301]
- 2897. [bug] NSEC3 chains could be left behind when transitioning to insecure. [RT #21040]
- 2896. [bug] "rndc sign" failed to properly update the zone when adding a DNSKEY for publication only. [RT #21045]
- 2895. [func] genrandom: add support for the generation of multiple files. [RT #20917]
- 2894. [contrib] DLZ LDAP support now use '\$' not '%'. [RT #21294]
- 2893. [bug] Improve managed keys support. New named.conf option managed-keys-directory. [RT #20924]
- 2892. [bug] Handle REVOKED keys better. [RT #20961]
- 2891. [maint] Update empty-zones list to match draft-ietf-dnsop-default-local-zones-13. [RT #21099]
- 2890. [bug] Handle the introduction of new trusted-keys and DS, DLV RRsets better. [RT #21097]
- 2889. [bug] Elements of the grammar where not properly reported. [RT #21046]
- 2888. [bug] Only the first EDNS option was displayed. [RT #21273]
- 2887. [bug] Report the keytag times in UTC in the .key file, local time is presented as a comment within the comment. [RT #21223]

(continues on next page)

(continued from previous page)

- 2886. [bug] ctime() is not thread safe. [RT #21223]
- 2885. [bug] Improve -fno-strict-aliasing support probing in configure. [RT #21080]
- 2884. [bug] Insufficient validation in dns\_name\_getlabelsequence(). [RT #21283]
- 2883. [bug] 'dig +short' failed to handle really large datasets. [RT #21113]
- 2882. [bug] Remove memory context from list of active contexts before clearing 'magic'. [RT #21274]
- 2881. [bug] Reduce the amount of time the rbtodb write lock is held when closing a version. [RT #21198]
- 2880. [cleanup] Make the output of dnssec-keygen and dnssec-revoke consistent. [RT #21078]
- 2879. [contrib] DLZ bdbhpt driver fails to close correct cursor. [RT #21106]
- 2878. [func] Incrementally write the master file after performing a AXFR. [RT #21010]
- 2877. [bug] The validator failed to skip obviously mismatching RRSIGs. [RT #21138]
- 2876. [bug] Named could return SERVFAIL for negative responses from unsigned zones. [RT #21131]
- 2875. [bug] dns\_time64\_fromtext() could accept non digits. [RT #21033]
- 2874. [bug] Cache lack of EDNS support only after the server successfully responds to the query using plain DNS. [RT #20930]
- 2873. [bug] Canceling a dynamic update via the dns/client module could trigger an assertion failure. [RT #21133]
- 2872. [bug] Modify dns/client.c:dns\_client\_createx() to only require one of IPv4 or IPv6 rather than both. [RT #21122]
- 2871. [bug] Type mismatch in mem\_api.c between the definition and the header file, causing build failure with --enable-exportlib. [RT #21138]
- 2870. [maint] Add AAAA address for L.ROOT-SERVERS.NET.

(continues on next page)

(continued from previous page)

- 2869. [bug] Fix arguments to `dns_keytable_findnextkeynode()` call. [RT #20877]
- 2868. [cleanup] Run "make clean" at the end of configure to ensure any changes made by configure are integrated. Use `--with-make-clean=no` to disable. [RT #20994]
- 2867. [bug] Don't set `GSS_C_SEQUENCE_FLAG` as Windows DNS servers don't like it. [RT #20986]
- 2866. [bug] Windows does not like the TSIG name being compressed. [RT #20986]
- 2865. [bug] `memset` to zero `event.data`. [RT #20986]
- 2864. [bug] Direct SIG/RRSIG queries were not handled correctly. [RT #21050]
- 2863. [port] linux: disable IPv6 PMTUD and use network minimum MTU. [RT #21056]
- 2862. [bug] `nsupdate` didn't default to the parent zone when updating DS records. [RT #20896]
- 2861. [doc] `dnssec-settime` man pages didn't correctly document the inactivation time. [RT #21039]
- 2860. [bug] `named-checkconf`'s usage was out of date. [RT #21039]
- 2859. [bug] When canceling validation it was possible to leak memory. [RT #20800]
- 2858. [bug] RTT estimates were not being adjusted on ICMP errors. [RT #20772]
- 2857. [bug] `named-checkconf` did not fail on a bad trusted key. [RT #20705]
- 2856. [bug] The size of a memory allocation was not always properly recorded. [RT #20927]
- 2855. [func] `nsupdate` will now preserve the entered case of domain names in update requests it sends. [RT #20928]
- 2854. [func] dig: allow the final soa record in a `axfr` response to be suppressed, `dig +onesoa`. [RT #20929]
- 2853. [bug] `add_sigs()` could run out of scratch space. [RT #21015]
- 2852. [bug] Handle broken DNSSEC trust chains better. [RT #15619]

(continues on next page)

(continued from previous page)

- 2851. [doc] nslookup.1, removed <informalexample> from the docbook source as it produced bad nroff. [RT #21007]
- 2850. [bug] If isc\_heap\_insert() failed due to memory shortage the heap would have corrupted entries. [RT #20951]
- 2849. [bug] Don't treat errors from the xml2 library as fatal. [RT #20945]
- 2848. [doc] Moved README.dnssec, README.libdns, README.pkcs11 and README.rfc5011 into the ARM. [RT #20899]
- 2847. [cleanup] Corrected usage message in dnssec-settime. [RT #20921]
- 2846. [bug] EOF on unix domain sockets was not being handled correctly. [RT #20731]
- 2845. [bug] RFC 5011 client could crash on shutdown. [RT #20903]
- 2844. [doc] notify-delay default in ARM was wrong. It should have been five (5) seconds.
- 2843. [func] Prevent dnssec-keygen and dnssec-keyfromlabel from creating key files if there is a chance that the new key ID will collide with an existing one after either of the keys has been revoked. (To override this in the case of dnssec-keyfromlabel, use the -y option. dnssec-keygen will simply create a different, non-colliding key, so an override is not necessary.) [RT #20838]
- 2842. [func] Added "smartsign" and improved "autosign" and "dnssec" regression tests. [RT #20865]
- 2841. [bug] Change 2836 was not complete. [RT #20883]
- 2840. [bug] Temporary fixed pkcs11-destroy usage check. [RT #20760]
- 2839. [bug] A KSK revoked by named could not be deleted. [RT #20881]
- 2838. [placeholder]
- 2837. [port] Prevent Linux spurious warnings about fwrite(). [RT #20812]
- 2836. [bug] Keys that were scheduled to become active could be delayed. [RT #20874]
- 2835. [bug] Key inactivity dates were inadvertently stored in the private key file with the outdated tag

(continues on next page)

(continued from previous page)

		"Unpublish" rather than "Inactive". This has been fixed; however, any existing keys that had Inactive dates set will now need to have them reset, using 'dnssec-settime -I'. [RT #20868]
2834.	[bug]	HMAC-SHA* keys that were longer than the algorithm digest length were used incorrectly, leading to interoperability problems with other DNS implementations. This has been corrected. (Note: If an oversize key is in use, and compatibility is needed with an older release of BIND, the new tool "isc-hmac-fixup" can convert the key secret to a form that will work with all versions.) [RT #20751]
2833.	[cleanup]	Fix usage messages in dnssec-keygen and dnssec-settime. [RT #20851]
2832.	[bug]	Modify "struct stat" in lib/export/samples/nsprobe.c to avoid redefinition in some OSs [RT 20831]
2831.	[security]	Do not attempt to validate or cache out-of-bailiwick data returned with a secure answer; it must be re-fetched from its original source and validated in that context. [RT #20819]
2830.	[bug]	Changing the OPTOUT setting could take multiple passes. [RT #20813]
2829.	[bug]	Fixed potential node inconsistency in rbtddb.c. [RT #20808]
2828.	[security]	Cached CNAME or DNAME RR could be returned to clients without DNSSEC validation. [RT #20737]
2827.	[security]	Bogus NXDOMAIN could be cached as if valid. [RT #20712]
2826.	[bug]	NSEC3->NSEC transitions could fail due to a lock not being released. [RT #20740]
2825.	[bug]	Changing the setting of OPTOUT in a NSEC3 chain that was in the process of being created was not properly recorded in the zone. [RT #20786]
2824.	[bug]	"rndc sign" was not being run by the correct task. [RT #20759]
2823.	[bug]	rbtddb.c:getsigningtime() was missing locks. [RT #20781]
2822.	[bug]	rbtddb.c:loadnode() could return the wrong result. [RT #20802]

(continues on next page)

(continued from previous page)

2821.	[doc]	Add note that named-checkconf doesn't automatically read rndc.key and bind.keys [RT #20758]
2820.	[func]	Handle read access failure of OpenSSL configuration file more user friendly (PKCS#11 engine patch). [RT #20668]
2819.	[cleanup]	Removed unnecessary DNS_POINTER_MAXHOPS define. [RT #20771]
2818.	[cleanup]	rndc could return an incorrect error code when a zone was not found. [RT #20767]
2817.	[cleanup]	Removed unnecessary isc_task_endexclusive() calls. [RT #20768]
2816.	[bug]	previous_closest_nsec() could fail to return data for NSEC3 nodes [RT #29730]
2815.	[bug]	Exclusively lock the task when freezing a zone. [RT #19838]
2814.	[func]	Provide a definitive error message when a master zone is not loaded. [RT #20757]
2813.	[bug]	Better handling of unreadable DNSSEC key files. [RT #20710]
2812.	[bug]	Make sure updates can't result in a zone with NSEC-only keys and NSEC3 records. [RT #20748]
2811.	[cleanup]	Add "rndc sign" to list of commands in rndc usage output. [RT #20733]
2810.	[doc]	Clarified the process of transitioning an NSEC3 zone to insecure. [RT #20746]
2809.	[cleanup]	Restored accidentally-deleted text in usage output in dnssec-settime and dnssec-revoke [RT #20739]
2808.	[bug]	Remove the attempt to install atomic.h from lib/isc. atomic.h is correctly installed by the architecture specific subdirectories. [RT #20722]
2807.	[bug]	Fixed a possible ASSERT when reconfiguring zone keys. [RT #20720]

--- 9.7.0rc1 released ---

2806.	[bug]	"rdnc sign" could delay re-signing the DNSKEY when it had changed. [RT #20703]
-------	-------	--

(continues on next page)

(continued from previous page)

- 2805. [bug] Fixed namespace problems encountered when building external programs using non-exported BIND9 libraries (i.e., built without --enable-exportlib). [RT #20679]
- 2804. [bug] Send notifies when a zone is signed with "rndc sign" or as a result of a scheduled key change. [RT #20700]
- 2803. [port] win32: Install named-journalprint, nsec3hash, arpaname and genrandom under windows. [RT #20670]
- 2802. [cleanup] Rename journalprint to named-journalprint. [RT #20670]
- 2801. [func] Detect and report records that are different according to DNSSEC but are semantically equal according to plain DNS. Apply plain DNS comparisons rather than DNSSEC comparisons when processing UPDATE requests. dnssec-signzone now removes such semantically duplicate records prior to signing the RRset.  
  
named-checkzone -r {ignore|warn|fail} (default warn)  
named-compilezone -r {ignore|warn|fail} (default warn)  
  
named.conf: check-dup-records {ignore|warn|fail};
- 2800. [func] Reject zones which have NS records which refer to CNAMEs, DNAMEs or don't have address record (class IN only). Reject UPDATES which would cause the zone to fail the above checks if committed. [RT #20678]
- 2799. [cleanup] Changed the "secure-to-insecure" option to "dnssec-secure-to-insecure", and "dnskey-ksk-only" to "dnssec-dnskey-kskonly", for clarity. [RT #20586]
- 2798. [bug] Addressed bugs in managed-keys initialization and rollover. [RT #20683]
- 2797. [bug] Don't decrement the dispatch manager's maxbuffers. [RT #20613]
- 2796. [bug] Missing dns\_rdataset\_disassociate() call in dns\_nsec3\_delnsec3sx(). [RT #20681]
- 2795. [cleanup] Add text to differentiate "update with no effect" log messages. [RT #18889]
- 2794. [bug] Install <isc/namespace.h>. [RT #20677]
- 2793. [func] Add "autosign" and "metadata" tests to the automatic tests. [RT #19946]
- 2792. [func] "filter-aaaa-on-v4" can now be set in view options (if compiled in). [RT #20635]

(continues on next page)

(continued from previous page)

- 2791. [bug] The installation of isc-config.sh was broken. [RT #20667]
- 2790. [bug] Handle DS queries to stub zones. [RT #20440]
- 2789. [bug] Fixed an INSIST in dispatch.c [RT #20576]
- 2788. [bug] dnssec-signzone could sign with keys that were not requested [RT #20625]
- 2787. [bug] Spurious log message when zone keys were dynamically reconfigured. [RT #20659]
- 2786. [bug] Additional could be promoted to answer. [RT #20663]

--- 9.7.0b3 released ---

- 2785. [bug] Revoked keys could fail to self-sign [RT #20652]
- 2784. [bug] TC was not always being set when required glue was dropped. [RT #20655]
- 2783. [func] Return minimal responses to EDNS/UDP queries with a UDP buffer size of 512 or less. [RT #20654]
- 2782. [port] win32: use getaddrinfo() for hostname lookups. [RT #20650]
- 2781. [bug] Inactive keys could be used for signing. [RT #20649]
- 2780. [bug] dnssec-keygen -A none didn't properly unset the activation date in all cases. [RT #20648]
- 2779. [bug] Dynamic key revocation could fail. [RT #20644]
- 2778. [bug] dnssec-signzone could fail when a key was revoked without deleting the unrevoked version. [RT #20638]
- 2777. [contrib] DLZ MYSQL auto reconnect support discovery was wrong.
- 2776. [bug] Change #2762 was not correct. [RT #20647]
- 2775. [bug] Accept RSASHA256 and RSASHA512 as NSEC3 compatible in dnssec-keyfromlabel. [RT #20643]
- 2774. [bug] Existing cache DB wasn't being reused after reconfiguration. [RT #20629]
- 2773. [bug] In autosigned zones, the SOA could be signed with the KSK. [RT #20628]

(continues on next page)

(continued from previous page)

2772.	[security]	When validating, track whether pending data was from the additional section or not and only return it if validates as secure. [RT #20438]
2771.	[bug]	dnssec-signzone: DNSKEY records could be corrupted when importing from key files [RT #20624]
2770.	[cleanup]	Add log messages to resolver.c to indicate events causing FORMERR responses. [RT #20526]
2769.	[cleanup]	Change #2742 was incomplete. [RT #19589]
2768.	[bug]	dnssec-signzone: -S no longer implies -g [RT #20568]
2767.	[bug]	named could crash on startup if a zone was configured with auto-dnssec and there was no key-directory. [RT #20615]
2766.	[bug]	isc_socket_fdwatchpoke() should only update the socketmgr state if the socket is not pending on a read or write. [RT #20603]
2765.	[bug]	Skip masters for which the TSIG key cannot be found. [RT #20595]
2764.	[bug]	"rndc-confgen -a" could trigger a REQUIRE. [RT #20610]
2763.	[bug]	"rndc sign" didn't create an NSEC chain. [RT #20591]
2762.	[bug]	DLV validation failed with a local slave DLV zone. [RT #20577]
2761.	[cleanup]	Enable internal symbol table for backtrace only for systems that are known to work. Currently, BSD variants, Linux and Solaris are supported. [RT #20202]
2760.	[cleanup]	Corrected named-compilezone usage summary. [RT #20533]
2759.	[doc]	Add information about .jbk/.jnw files to the ARM. [RT #20303]
2758.	[bug]	win32: Added a workaround for a windows 2008 bug that could cause the UDP client handler to shut down. [RT #19176]
2757.	[bug]	dig: assertion failure could occur in connect timeout. [RT #20599]
2756.	[bug]	Fixed corrupt logfile message in update.c. [RT #20597]
2755.	[placeholder]	

(continues on next page)

(continued from previous page)

2754.	[bug]	Secure-to-insecure transitions failed when zone was signed with NSEC3. [RT #20587]
2753.	[bug]	Removed an unnecessary warning that could appear when building an NSEC chain. [RT #20589]
2752.	[bug]	Locking violation. [RT #20587]
2751.	[bug]	Fixed a memory leak in dnssec-keyfromlabel. [RT #20588]
2750.	[bug]	dig: assertion failure could occur when a server didn't have an address. [RT #20579]
2749.	[bug]	ixfr-from-differences generated a non-minimal ixfr for NSEC3 signed zones. [RT #20452]
2748.	[func]	Identify bad answers from GTLD servers and treat them as referrals. [RT #18884]
2747.	[bug]	Journal roll forwards failed to set the re-signing time of RRSIGs correctly. [RT #20541]
2746.	[port]	hpux: address signed/unsigned expansion mismatch of dns_rbtnode_t.nsec. [RT #20542]
2745.	[bug]	configure script didn't probe the return type of gai_strerror(3) correctly. [RT #20573]
2744.	[func]	Log if a query was over TCP. [RT #19961]
2743.	[bug]	RRSIG could be incorrectly set in the NSEC3 record for a insecure delegation.

--- 9.7.0b2 released ---

2742.	[cleanup]	Clarify some DNSSEC-related log messages in validator.c. [RT #19589]
2741.	[func]	Allow the dnssec-keygen progress messages to be suppressed (dnssec-keygen -q). Automatically suppress the progress messages when stdin is not a tty. [RT #20474]
2740.	[placeholder]	
2739.	[cleanup]	Clean up API for initializing and clearing trust anchors for a view. [RT #20211]
2738.	[func]	Add RSASHA256 and RSASHA512 tests to the dnssec system test. [RT #20453]
2737.	[func]	UPDATE requests can leak existence information.

(continues on next page)

(continued from previous page)

		[RT #17261]
2736.	[func]	Improve the performance of NSEC signed zones with more than a normal amount of glue below a delegation. [RT #20191]
2735.	[bug]	dnssec-signzone could fail to read keys that were specified on the command line with full paths, but weren't in the current directory. [RT #20421]
2734.	[port]	cygwin: arpaname did not compile. [RT #20473]
2733.	[cleanup]	Clean up coding style in pkcs11-* tools. [RT #20355]
2732.	[func]	Add optional filter-aaaa-on-v4 option, available if built with './configure --enable-filter-aaaa'. Filters out AAAA answers to clients connecting via IPv4. (This is NOT recommended for general use.) [RT #20339]
2731.	[func]	Additional work on change 2709. The key parser will now ignore unrecognized fields when the minor version number of the private key format has been increased. It will reject any key with the major version number increased. [RT #20310]
2730.	[func]	Have dnssec-keygen display a progress indication a la 'openssl genrsa' on standard error. Note when the first '.' is followed by a long stop one has the choice between slow generation vs. poor random quality, i.e., '-r /dev/urandom'. [RT #20284]
2729.	[func]	When constructing a CNAME from a DNAME use the DNAME TTL. [RT #20451]
2728.	[bug]	dnssec-keygen, dnssec-keyfromlabel and dnssec-signzone now warn immediately if asked to write into a nonexistent directory. [RT #20278]
2727.	[func]	The 'key-directory' option can now specify a relative path. [RT #20154]
2726.	[func]	Added support for SHA-2 DNSSEC algorithms, RSASHA256 and RSASHA512. [RT #20023]
2725.	[doc]	Added information about the file "managed-keys.bind" to the ARM. [RT #20235]
2724.	[bug]	Updates to a existing node in secure zone using NSEC were failing. [RT #20448]

(continues on next page)

(continued from previous page)

- 2723. [bug] `isc_base32_totext()`, `isc_base32hex_totext()`, and `isc_base64_totext()`, didn't always mark regions of memory as fully consumed after conversion. [RT #20445]
- 2722. [bug] Ensure that the memory associated with the name of a node in a rbt tree is not altered during the life of the node. [RT #20431]
- 2721. [port] Have `dst__entropy_status()` prime the random number generator. [RT #20369]
- 2720. [bug] RFC 5011 trust anchor updates could trigger an assert if the DNSKEY record was unsigned. [RT #20406]
- 2719. [func] Skip trusted/managed keys for unsupported algorithms. [RT #20392]
- 2718. [bug] The space calculations in `opensslrsa_todns()` were incorrect. [RT #20394]
- 2717. [bug] `named` failed to update the NSEC/NSEC3 record when the last private type record was removed as a result of completing the signing the zone with a key. [RT #20399]
- 2716. [bug] `nslookup` debug mode didn't return the ttl. [RT #20414]

--- 9.7.0b1 released ---

- 2715. [bug] Require OpenSSL support to be explicitly disabled. [RT #20288]
- 2714. [port] `aix/powerpc: 'asm("ics");'` needs non standard assembler flags.
- 2713. [bug] `powerpc: atomic operations missing asm("ics") / __isync()` calls.
- 2712. [func] New 'auto-dnssec' zone option allows zone signing to be fully automated in zones configured for dynamic DNS. 'auto-dnssec allow;' permits a zone to be signed by creating keys for it in the key-directory and using 'rndc sign <zone>'. 'auto-dnssec maintain;' allows that too, plus it also keeps the zone's DNSSEC keys up to date according to their timing metadata. [RT #19943]
- 2711. [port] `win32: Add the bin/pkcs11 tools into the full build.` [RT #20372]
- 2710. [func] New 'dnssec-signzone -x' flag and 'dnskey-ksk-only'

(continues on next page)

(continued from previous page)

- zone option cause a zone to be signed with only KSKs signing the DNSKEY RRset, not ZSKs. This reduces the size of a DNSKEY answer. [RT #20340]
- 2709. [func] Added some data fields, currently unused, to the private key file format, to allow implementation of explicit key rollover in a future release without impairing backward or forward compatibility. [RT #20310]
- 2708. [func] Insecure to secure and NSEC3 parameter changes via update are now fully supported and no longer require defines to enable. We now no longer overload the NSEC3PARAM flag field, nor the NSEC OPT bit at the apex. Secure to insecure changes are controlled by by the named.conf option 'secure-to-insecure'.

Warning: If you had previously enabled support by adding defines at compile time to BIND 9.6 you should ensure that all changes that are in progress have completed prior to upgrading to BIND 9.7. BIND 9.7 is not backwards compatible.
- 2707. [func] dnssec-keyfromlabel no longer require engine name to be specified in the label if there is a default engine or the -E option has been used. Also, it now uses default algorithms as dnssec-keygen does (i.e., RSASHA1, or NSEC3RSASHA1 if -3 is used). [RT #20371]
- 2706. [bug] Loading a zone with a very large NSEC3 salt could trigger an assert. [RT #20368]
- 2705. [placeholder]
- 2704. [bug] Serial of dynamic and stub zones could be inconsistent with their SOA serial. [RT #19387]
- 2703. [func] Introduce an OpenSSL "engine" argument with -E for all binaries which can take benefit of crypto hardware. [RT #20230]
- 2702. [func] Update PKCS#11 tools (bin/pkcs11) [RT #20225 & all]
- 2701. [doc] Correction to ARM: hmac-md5 is no longer the only supported TSIG key algorithm. [RT #18046]
- 2700. [doc] The match-mapped-addresses option is discouraged. [RT #12252]
- 2699. [bug] Missing lock in rbtodb.c. [RT #20037]

(continues on next page)

(continued from previous page)

- 2698. [placeholder]
- 2697. [port] win32: ensure that S\_IFMT, S\_IFDIR, S\_IFCHR and S\_IFREG are defined after including <isc/stat.h>. [RT #20309]
- 2696. [bug] named failed to successfully process some valid acl constructs. [RT #20308]
- 2695. [func] DHCP/DDNS - update fdwatch code for use by DHCP. Modify the api to isc\_sockfdwatch\_t (the callback function for isc\_socket\_fdwatchcreate) to include information about the direction (read or write) and add isc\_socket\_fdwatchpoke. [RT #20253]
- 2694. [bug] Reduce default NSEC3 iterations from 100 to 10. [RT #19970]
- 2693. [port] Add some noreturn attributes. [RT #20257]
- 2692. [port] win32: 32/64 bit cleanups. [RT #20335]
- 2691. [func] dnssec-signzone: retain the existing NSEC or NSEC3 chain when re-signing a previously-signed zone. Use -u to modify NSEC3 parameters or switch between NSEC and NSEC3. [RT #20304]
- 2690. [bug] win32: fix isc\_thread\_key\_getspecific() prototype. [RT #20315]
- 2689. [bug] Correctly handle sprintf result. [RT #20306]
- 2688. [bug] Use INTERFACE\_F\_POINTTOPOINT, not IFF\_POINTTOPOINT, to decide to fetch the destination address. [RT #20305]
- 2687. [bug] Fixed dnssec-signzone -S handling of revoked keys. Also, added warnings when revoking a ZSK, as this is not defined by protocol (but is legal). [RT #19943]
- 2686. [bug] dnssec-signzone should clean the old NSEC chain when signing with NSEC3 and vice versa. [RT #20301]
- 2685. [contrib] Update contrib/zkt to version 0.99c. [RT #20054]
- 2684. [cleanup] dig: formalize +ad and +cd as synonyms for +adflag and +cdflag. [RT #19305]
- 2683. [bug] dnssec-signzone should clean out old NSEC3 chains when the NSEC3 parameters used to sign the zone change. [RT #20246]

(continues on next page)

(continued from previous page)

2682.	[bug]	"configure --enable-symtable=all" failed to build. [RT #20282]
2681.	[bug]	IPSECKEY RR of gateway type 3 was not correctly decoded. [RT #20269]
2680.	[func]	Move contrib/pkcs11-keygen to bin/pkcs11. [RT #20067]
2679.	[func]	dig -k can now accept TSIG keys in named.conf format. [RT #20031]
2678.	[func]	Treat DS queries as if "minimal-response yes;" was set. [RT #20258]
2677.	[func]	Changes to key metadata behavior: - Keys without "publish" or "active" dates set will no longer be used for smart signing. However, those dates will be set to "now" by default when a key is created; to generate a key but not use it yet, use dnssec-keygen -G. - New "inactive" date (dnssec-keygen/settime -I) sets the time when a key is no longer used for signing but is still published. - The "unpublished" date (-U) is deprecated in favor of "deleted" (-D). [RT #20247]
2676.	[bug]	--with-export-installdir should have been --with-export-includedir. [RT #20252]
2675.	[bug]	dnssec-signzone could crash if the key directory did not exist. [RT #20232]

--- 9.7.0a3 released ---		
2674.	[bug]	"dnssec-lookaside auto;" crashed if named was built without openssl. [RT #20231]
2673.	[bug]	The managed-keys.bind zone file could fail to load due to a spurious result from sync_keyzone() [RT #20045]
2672.	[bug]	Don't enable searching in 'host' when doing reverse lookups. [RT #20218]
2671.	[bug]	Add support for PKCS#11 providers not returning the public exponent in RSA private keys (OpenCryptoki for instance) in dnssec-keyfromlabel. [RT #19294]
2670.	[bug]	Unexpected connect failures failed to log enough information to be useful. [RT #20205]

(continues on next page)

(continued from previous page)

- 2669. [func] Update PKCS#11 support to support Keyper HSM.  
Update PKCS#11 patch to be against openssl-0.9.8i.
- 2668. [func] Several improvements to dnssec-\* tools, including:
  - dnssec-keygen and dnssec-settime can now set key metadata fields 0 (to unset a value, use "none")
  - dnssec-revoke sets the revocation date in addition to the revoke bit
  - dnssec-settime can now print individual metadata fields instead of always printing all of them, and can print them in unix epoch time format for use by scripts
 [RT #19942]
- 2667. [func] Add support for logging stack backtrace on assertion failure (not available for all platforms). [RT #19780]
- 2666. [func] Added an 'options' argument to dns\_name\_fromstring() (API change from 9.7.0a2). [RT #20196]
- 2665. [func] Clarify syntax for managed-keys {} statement, add ARM documentation about RFC 5011 support. [RT #19874]
- 2664. [bug] create\_keydata() and minimal\_update() in zone.c didn't properly check return values for some functions. [RT #19956]
- 2663. [func] win32: allow named to run as a service using "NT AUTHORITY\LocalService" as the account. [RT #19977]
- 2662. [bug] lwres\_getipnodebyname() and lwres\_getipnodebyaddr() returned a misleading error code when lwresd was down. [RT #20028]
- 2661. [bug] Check whether socket fd exceeds FD\_SETSIZE when creating lwres context. [RT #20029]
- 2660. [func] Add a new set of DNS libraries for non-BIND9 applications. See README.libdns. [RT #19369]
- 2659. [doc] Clarify dnssec-keygen doc: key name must match zone name for DNSSEC keys. [RT #19938]
- 2658. [bug] dnssec-settime and dnssec-revoke didn't process key file paths correctly. [RT #20078]
- 2657. [cleanup] Lower "journal file <path> does not exist, creating it" log level to debug 1. [RT #20058]
- 2656. [func] win32: add a "tools only" check box to the installer which causes it to only install dig, host, nslookup,

(continues on next page)

(continued from previous page)

		nsupdate and relevant DLLs. [RT #19998]
2655.	[doc]	Document that key-directory does not affect bind.keys, rndc.key or session.key. [RT #20155]
2654.	[bug]	Improve error reporting on duplicated names for deny-answer-xxx. [RT #20164]
2653.	[bug]	Treat ENGINE_load_private_key() failures as key not found rather than out of memory. [RT #18033]
2652.	[func]	Provide more detail about what record is being deleted. [RT #20061]
2651.	[bug]	Dates could print incorrectly in K*.key files on 64-bit systems. [RT #20076]
2650.	[bug]	Assertion failure in dnssec-signzone when trying to read keyset-* files. [RT #20075]
2649.	[bug]	Set the domain for forward only zones. [RT #19944]
2648.	[port]	win32: isc_time_seconds() was broken. [RT #19900]
2647.	[bug]	Remove unnecessary SOA updates when a new KSK is added. [RT #19913]
2646.	[bug]	Incorrect cleanup on error in socket.c. [RT #19987]
2645.	[port]	"gcc -m32" didn't work on amd64 and x86_64 platforms which default to 64 bits. [RT #19927]

		--- 9.7.0a2 released ---
2644.	[bug]	Change #2628 caused a regression on some systems; named was unable to write the PID file and would fail on startup. [RT #20001]
2643.	[bug]	Stub zones interacted badly with NSEC3 support. [RT #19777]
2642.	[bug]	nsupdate could dump core on solaris when reading improperly formatted key files. [RT #20015]
2641.	[bug]	Fixed an error in parsing update-policy syntax, added a regression test to check it. [RT #20007]
2640.	[security]	A specially crafted update packet will cause named to exit. [RT #20000]
2639.	[bug]	Silence compiler warnings in gssapi code. [RT #19954]

(continues on next page)

(continued from previous page)

- 2638. [bug] Install arpaname. [RT #19957]
- 2637. [func] Rationalize dnssec-signzone's signwithkey() calling. [RT #19959]
- 2636. [func] Simplify zone signing and key maintenance with the dnssec-\* tools. Major changes:
  - all dnssec-\* tools now take a -K option to specify a directory in which key files will be stored
  - DNSSEC can now store metadata indicating when they are scheduled to be published, activated, revoked or removed; these values can be set by dnssec-keygen or overwritten by the new dnssec-settime command
  - dnssec-signzone -S (for "smart") option reads key metadata and uses it to determine automatically which keys to publish to the zone, use for signing, revoke, or remove from the zone
 [RT #19816]
- 2635. [bug] isc\_inet\_ntop() incorrectly handled 0.0/16 addresses. [RT #19716]
- 2634. [port] win32: Add support for libxml2, enable statschannel. [RT #19773]
- 2633. [bug] Handle 15 bit rand() functions. [RT #19783]
- 2632. [func] util/kit.sh: warn if documentation appears to be out of date. [RT #19922]
- 2631. [bug] Handle "/", "./" and "../" in mkdirpath(). [RT #19926 ]
- 2630. [func] Improved syntax for DDNS autoconfiguration: use "update-policy local;" to switch on local DDNS in a zone. (The "ddns-autoconf" option has been removed.) [RT #19875]
- 2629. [port] Check for seteuid()/setegid(), use setresuid()/setresgid() if not present. [RT #19932]
- 2628. [port] linux: Allow /var/run/named/named.pid to be opened at startup with reduced capabilities in operation. [RT #19884]
- 2627. [bug] Named aborted if the same key was included in trusted-keys more than once. [RT #19918]
- 2626. [bug] Multiple trusted-keys could trigger an assertion failure. [RT #19914]

(continues on next page)

(continued from previous page)

- 2625. [bug] Missing UNLOCK in rbtodb.c. [RT #19865]
- 2624. [func] 'named-checkconf -p' will print out the parsed configuration. [RT #18871]
- 2623. [bug] Named started searches for DS non-optimally. [RT #19915]
- 2622. [bug] Printing of named.conf grammar was broken. [RT #19919]
- 2621. [doc] Made copyright boilerplate consistent. [RT #19833]
- 2620. [bug] Delay thawing the zone until the reload of it has completed successfully. [RT #19750]
- 2619. [func] Add support for RFC 5011, automatic trust anchor maintenance. The new "managed-keys" statement can be used in place of "trusted-keys" for zones which support this protocol. (Note: this syntax is expected to change prior to 9.7.0 final.) [RT #19248]
- 2618. [bug] The sdb and sdlz db\_iterator\_seek() methods could loop infinitely. [RT #19847]
- 2617. [bug] ifconfig.sh failed to emit an error message when run from the wrong location. [RT #19375]
- 2616. [bug] 'host' used the nameservers from resolv.conf even when a explicit nameserver was specified. [RT #19852]
- 2615. [bug] "\_\_attribute\_\_((unused))" was in the wrong place for ia64 gcc builds. [RT #19854]
- 2614. [port] win32: 'named -v' should automatically be executed in the foreground. [RT #19844]
- 2613. [placeholder]

--- 9.7.0a1 released ---

- 2612. [func] Add default values for the arguments to dnssec-keygen. Without arguments, it will now generate a 1024-bit RSASHA1 zone-signing key, or with the -f KSK option, a 2048-bit RSASHA1 key-signing key. [RT #19300]
- 2611. [func] Add -l option to dnssec-dsfromkey to generate DLV records instead of DS records. [RT #19300]
- 2610. [port] sunos: Change #2363 was not complete. [RT #19796]
- 2609. [func] Simplify the configuration of dynamic zones:

(continues on next page)

(continued from previous page)

		<ul style="list-style-type: none"> <li>- add ddns-confgen command to generate configuration text for named.conf</li> <li>- add zone option "ddns-autoconf yes;", which causes named to generate a TSIG session key and allow updates to the zone using that key</li> <li>- add '-l' (localhost) option to nsupdate, which causes nsupdate to connect to a locally-running named process using the session key generated by named</li> </ul> <p>[RT #19284]</p>
2608.	[func]	<p>Perform post signing verification checks in dnssec-signzone. These can be disabled with -P.</p> <p>The post sign verification test ensures that for each algorithm in use there is at least one non revoked self signed KSK key. That all revoked KSK keys are self signed. That all records in the zone are signed by the algorithm. [RT #19653]</p>
2607.	[bug]	<p>named could incorrectly delete NSEC3 records for empty nodes when processing a update request. [RT #19749]</p>
2606.	[bug]	<p>"delegation-only" was not being accepted in delegation-only type zones. [RT #19717]</p>
2605.	[bug]	<p>Accept DS responses from delegation only zones. [RT # 19296]</p>
2604.	[func]	<p>Add support for DNS rebinding attack prevention through new options, deny-answer-addresses and deny-answer-aliases. Based on contributed code from JD Nurmi, Google. [RT #18192]</p>
2603.	[port]	<p>win32: handle .exe extension of named-checkzone and named-comilezone argv[0] names under windows. [RT #19767]</p>
2602.	[port]	<p>win32: fix debugging command line build of libisccfg. [RT #19767]</p>
2601.	[doc]	<p>Mention file creation mode mask in the named manual page.</p>
2600.	[doc]	<p>ARM: miscellaneous reformatting for different page widths. [RT #19574]</p>
2599.	[bug]	<p>Address rapid memory growth when validation fails. [RT #19654]</p>
2598.	[func]	<p>Reserve the -F flag. [RT #19657]</p>

(continues on next page)

(continued from previous page)

- 2597. [bug] Handle a validation failure with a insecure delegation from a NSEC3 signed master/slave zone. [RT #19464]
- 2596. [bug] Stale tree nodes of cache/dynamic rbtodb could stay long, leading to inefficient memory usage or rejecting newer cache entries in the worst case. [RT #19563]
- 2595. [bug] Fix unknown extended rcodes in dig. [RT #19625]
- 2594. [func] Have rndc warn if using its default configuration file when the key file also exists. [RT #19424]
- 2593. [bug] Improve a corner source of SERVFAILs [RT #19632]
- 2592. [bug] Treat "any" as a type in nsupdate. [RT #19455]
- 2591. [bug] named could die when processing a update in removed\_orphaned\_ds(). [RT #19507]
- 2590. [func] Report zone/class of "update with no effect". [RT #19542]
- 2589. [bug] dns\_db\_unregister() failed to clear '\*dbimp'. [RT #19626]
- 2588. [bug] SO\_REUSEADDR could be set unconditionally after failure of bind(2) call. This should be rare and mostly harmless, but may cause interference with other processes that happen to use the same port. [RT #19642]
- 2587. [func] Improve logging by reporting serial numbers for when zone serial has gone backwards or unchanged. [RT #19506]
- 2586. [bug] Missing cleanup of SIG rdataset in searching a DLZ DB or SDB. [RT #19577]
- 2585. [bug] Uninitialized socket name could be referenced via a statistics channel, triggering an assertion failure in XML rendering. [RT #19427]
- 2584. [bug] alpha: gcc optimization could break atomic operations. [RT #19227]
- 2583. [port] netbsd: provide a control to not add the compile date to the version string, -DNO\_VERSION\_DATE.
- 2582. [bug] Don't emit warning log message when we attempt to remove non-existent journal. [RT #19516]
- 2581. [contrib] dlz/mysql set MYSQL\_OPT\_RECONNECT option on connection.

(continues on next page)

(continued from previous page)

		Requires MySQL 5.0.19 or later. [RT #19084]
2580.	[bug]	UpdateRej statistics counter could be incremented twice for one rejection. [RT #19476]
2579.	[bug]	DNSSEC lookaside validation failed to handle unknown algorithms. [RT #19479]
2578.	[bug]	Changed default sig-signing-type to 65534, because 65535 turns out to be reserved. [RT #19477]
2577.	[doc]	Clarified some statistics counters. [RT #19454]
2576.	[bug]	NSEC record were not being correctly signed when a zone transitions from insecure to secure. Handle such incorrectly signed zones. [RT #19114]
2575.	[func]	New functions dns_name_fromstring() and dns_name_tostring(), to simplify conversion of a string to a dns_name structure and vice versa. [RT #19451]
2574.	[doc]	Document nsupdate -g and -o. [RT #19351]
2573.	[bug]	Replacing a non-CNAME record with a CNAME record in a single transaction in a signed zone failed. [RT #19397]
2572.	[func]	Simplify DLV configuration, with a new option "dnssec-lookaside auto;" This is the equivalent of "dnssec-lookaside . trust-anchor dlv.isc.org;" plus setting a trusted-key for dlv.isc.org.  Note: The trusted key is hard-coded into named, but is also stored in (and can be overridden by) \$sysconfdir/bind.keys. As the ISC DLV key rolls over it can be kept up to date by replacing the bind.keys file with a key downloaded from <a href="https://www.isc.org/solutions/dlv">https://www.isc.org/solutions/dlv</a> . [RT #18685]
2571.	[func]	Add a new tool "arpaname" which translates IP addresses to the corresponding IN-ADDR.ARPA or IP6.ARPA name. [RT #18976]
2570.	[func]	Log the destination address the query was sent to. [RT #19209]
2569.	[func]	Move journalprint, nsec3hash, and genrandom commands from bin/tests into bin/tools; "make install" will put them in \$sbindir. [RT #19301]
2568.	[bug]	Report when the write to indicate a otherwise successful start fails. [RT #19360]

(continues on next page)

(continued from previous page)

- 2567. [bug]           dst\_\_privstruct\_writefile() could miss write errors.  
write\_public\_key() could miss write errors.  
dnssec-dsfromkey could miss write errors.  
[RT #19360]
  
- 2566. [cleanup]       Clarify logged message when an insecure DNSSEC  
response arrives from a zone thought to be secure:  
"insecurity proof failed" instead of "not  
insecure". [RT #19400]
  
- 2565. [func]           Add support for HIP record. Includes new functions  
dns\_rdata\_hip\_first(), dns\_rdata\_hip\_next()  
and dns\_rdata\_hip\_current(). [RT #19384]
  
- 2564. [bug]           Only take EDNS fallback steps when processing timeouts.  
[RT #19405]
  
- 2563. [bug]           Dig could leak a socket causing it to wait forever  
to exit. [RT #19359]
  
- 2562. [doc]           ARM: miscellaneous improvements, reorganization,  
and some new content.
  
- 2561. [doc]           Add isc-config.sh(1) man page. [RT #16378]
  
- 2560. [bug]           Add #include <config.h> to iptable.c. [RT #18258]
  
- 2559. [bug]           dnssec-dsfromkey could compute bad DS records when  
reading from a K\* files. [RT #19357]
  
- 2558. [func]           Set the ownership of missing directories created  
for pid-file if -u has been specified on the command  
line. [RT #19328]
  
- 2557. [cleanup]       PCI compliance:  
\* new libisc log module file  
\* isc\_dir\_chroot() now also changes the working  
  directory to "/".  
\* additional INSISTS  
\* additional logging when files can't be removed.
  
- 2556. [port]           Solaris: mkdir(2) on tmpfs filesystems does not do the  
error checks in the correct order resulting in the  
wrong error code sometimes being returned. [RT #19249]
  
- 2555. [func]           dig: when emitting a hex dump also display the  
corresponding characters. [RT #19258]
  
- 2554. [bug]           Validation of uppercase queries from NSEC3 zones could  
fail. [RT #19297]

(continues on next page)

(continued from previous page)

- 2553. [bug] Reference leak on DNSSEC validation errors. [RT #19291]
- 2552. [bug] zero-no-soa-ttl-cache was not being honored.  
[RT #19340]
- 2551. [bug] Potential Reference leak on return. [RT #19341]
- 2550. [bug] Check --with-openssl=<path> finds <openssl/opensslv.h>.  
[RT #19343]
- 2549. [port] linux: define NR\_OPEN if not currently defined.  
[RT #19344]
- 2548. [bug] Install iterated\_hash.h. [RT #19335]
- 2547. [bug] openssl\_link.c:mem\_realloc() could reference an  
out-of-range area of the source buffer. New public  
function isc\_mem\_reallocate() was introduced to address  
this bug. [RT #19313]
- 2546. [func] Add --enable-openssl-hash configure flag to use  
OpenSSL (in place of internal routine) for hash  
functions (MD5, SHA[12] and HMAC). [RT #18815]
- 2545. [doc] ARM: Legal hostname checking (check-names) is  
for SRV RDATA too. [RT #19304]
- 2544. [cleanup] Removed unused structure members in adb.c. [RT #19225]
- 2543. [contrib] Update contrib/zkt to version 0.98. [RT #19113]
- 2542. [doc] Update the description of dig +adflag. [RT #19290]
- 2541. [bug] Conditionally update dispatch manager statistics.  
[RT #19247]
- 2540. [func] Add a nibble mode to \$GENERATE. [RT #18872]
- 2539. [security] Update the interaction between recursion, allow-query,  
allow-query-cache and allow-recursion. [RT #19198]
- 2538. [bug] cache/ADB memory could grow over max-cache-size,  
especially with threads and smaller max-cache-size  
values. [RT #19240]
- 2537. [func] Added more statistics counters including those on socket  
I/O events and query RTT histograms. [RT #18802]
- 2536. [cleanup] Silence some warnings when -Werror=format-security is  
specified. [RT #19083]
- 2535. [bug] dig +showsearch and +trace interacted badly. [RT #19091]

(continues on next page)

(continued from previous page)

- 2534. [func] Check NAPTR records regular expressions and replacement strings to ensure they are syntactically valid and consistent. [RT #18168]
- 2533. [doc] ARM: document @ (at-sign). [RT #17144]
- 2532. [bug] dig: check the question section of the response to see if it matches the asked question. [RT #18495]
- 2531. [bug] Change #2207 was incomplete. [RT #19098]
- 2530. [bug] named failed to reject insecure to secure transitions via UPDATE. [RT #19101]
- 2529. [cleanup] Upgrade libtool to silence complaints from recent version of autoconf. [RT #18657]
- 2528. [cleanup] Silence spurious configure warning about --datarootdir [RT #19096]
- 2527. [placeholder]
- 2526. [func] New named option "attach-cache" that allows multiple views to share a single cache to save memory and improve lookup efficiency. Based on contributed code from Barclay Osborn, Google. [RT #18905]
- 2525. [func] New logging category "query-errors" to provide detailed internal information about query failures, especially about server failures. [RT #19027]
- 2524. [port] sunos: dnssec-signzone needs strtoul(). [RT #19129]
- 2523. [bug] Random type rdata freed by dns\_nsec\_typepresent(). [RT #19112]
- 2522. [security] Handle -1 from DSA\_do\_verify() and EVP\_VerifyFinal().
- 2521. [bug] Improve epoll cross compilation support. [RT #19047]
- 2520. [bug] Update xml statistics version number to 2.0 as change #2388 made the schema incompatible to the previous version. [RT #19080]
- 2519. [bug] dig/host with -4 or -6 didn't work if more than two nameserver addresses of the excluded address family preceded in resolv.conf. [RT #19081]
- 2518. [func] Add support for the new CERT types from RFC 4398. [RT #19077]

(continues on next page)

(continued from previous page)

- 2517. [bug] dig +trace with -4 or -6 failed when it chose a nameserver address of the excluded address type. [RT #18843]
- 2516. [bug] glue sort for responses was performed even when not needed. [RT #19039]
- 2515. [port] win32: build dnssec-dsfromkey and dnssec-keyfromlabel. [RT #19063]
- 2514. [bug] dig/host failed with -4 or -6 when resolv.conf contains a nameserver of the excluded address family. [RT #18848]
- 2513. [bug] Fix windows cli build. [RT #19062]
- 2512. [func] Print a summary of the cached records which make up the negative response. [RT #18885]
- 2511. [cleanup] dns\_rdata\_tofmttext() add const to linebreak. [RT #18885]
- 2510. [bug] "dig +sigchase" could trigger REQUIRE failures. [RT #19033]
- 2509. [bug] Specifying a fixed query source port was broken. [RT #19051]
- 2508. [placeholder]
- 2507. [func] Log the recursion quota values when killing the oldest query or refusing to recurse due to quota. [RT #19022]
- 2506. [port] solaris: Check at configure time if hack\_shutup\_pthreadonceinit is needed. [RT #19037]
- 2505. [port] Treat amd64 similarly to x86\_64 when determining atomic operation support. [RT #19031]
- 2504. [bug] Address race condition in the socket code. [RT #18899]
- 2503. [port] linux: improve compatibility with Linux Standard Base. [RT #18793]
- 2502. [cleanup] isc\_radix: Improve compliance with coding style, document function in <isc/radix.h>. [RT #18534]
- 2501. [func] \$GENERATE now supports all rdata types. Multi-field rdata types need to be quoted. See the ARM for details. [RT #18368]

(continues on next page)

(continued from previous page)

2500.	[contrib]	contrib/sdb/pgsql/zonetodb.c called non-existent function. [RT #18582]
2499.	[port]	solaris: lib/lwres/getaddrinfo.c namespace clash. [RT #18837]

--- 9.6.0rc1 released ---		
2498.	[bug]	Removed a bogus function argument used with ISC_SOCKET_USE_POLLWATCH: it could cause compiler warning or crash named with the debug 1 level of logging. [RT #18917]
2497.	[bug]	Don't add RRSIG bit to NSEC3 bit map for insecure delegation.
2496.	[bug]	Add sanity length checks to NSID option. [RT #18813]
2495.	[bug]	Tighten RRSIG checks. [RT #18795]
2494.	[bug]	isc/radix.h, dns/sdlz.h and dns/dlz.h were not being installed. [RT #18826]
2493.	[bug]	The linux capabilities code was not correctly cleaning up after itself. [RT #18767]
2492.	[func]	Rndc status now reports the number of cpus discovered and the number of worker threads when running multi-threaded. [RT #18273]
2491.	[func]	Attempt to re-use a local port if we are already using the port. [RT #18548]
2490.	[port]	aix: work around a kernel bug where IPV6_RECVPKTINFO is cleared when IPV6_V6ONLY is set. [RT #18785]
2489.	[port]	solaris: Workaround Solaris's kernel bug about /dev/poll: <a href="http://bugs.opensolaris.org/view_bug.do?bug_id=6724237">http://bugs.opensolaris.org/view_bug.do?bug_id=6724237</a> Define ISC_SOCKET_USE_POLLWATCH at build time to enable this workaround. [RT #18870]
2488.	[func]	Added a tool, dnssec-dsfromkey, to generate DS records from keyset and .key files. [RT #18694]
2487.	[bug]	Give TCP connections longer to complete. [RT #18675]
2486.	[func]	The default locations for named.pid and lwresd.pid are now /var/run/named/named.pid and /var/run/lwresd/lwresd.pid respectively.  This allows the owner of the containing directory

(continues on next page)

(continued from previous page)

		to be set, for "named -u" support, and allows there to be a permanent symbolic link in the path, for "named -t" support. [RT #18306]
2485.	[bug]	Change update's the handling of obscured RRSIG records. Not all orphaned DS records were being removed. [RT #18828]
2484.	[bug]	It was possible to trigger a REQUIRE failure when adding NSEC3 proofs to the response in query_addwildcardproof(). [RT #18828]
2483.	[port]	win32: chroot() is not supported. [RT #18805]
2482.	[port]	libxml2: support versions 2.7.* in addition to 2.6.*. [RT #18806]

		--- 9.6.0b1 released ---
2481.	[bug]	rbtdb.c:matchparams() failed to handle NSEC3 chain collisions. [RT #18812]
2480.	[bug]	named could fail to emit all the required NSEC3 records. [RT #18812]
2479.	[bug]	xfrount:covers was not properly initialized. [RT #18801]
2478.	[bug]	'addresses' could be used uninitialized in configure_forward(). [RT #18800]
2477.	[bug]	dig: the global option to print the command line is +cmd not print_cmd. Update the output to reflect this. [RT #17008]
2476.	[doc]	ARM: improve documentation for max-journal-size and ixfr-from-differences. [RT #15909] [RT #18541]
2475.	[bug]	LRU cache cleanup under overmem condition could purge particular entries more aggressively. [RT #17628]
2474.	[bug]	ACL structures could be allocated with insufficient space, causing an array overrun. [RT #18765]
2473.	[port]	linux: raise the limit on open files to the possible maximum value before spawning threads; 'files' specified in named.conf doesn't seem to work with threads as expected. [RT #18784]
2472.	[port]	linux: check the number of available cpu's before calling chroot as it depends on "/proc". [RT #16923]
2471.	[bug]	named-checkzone was not reporting missing mandatory

(continues on next page)

(continued from previous page)

		glue when sibling checks were disabled. [RT #18768]
2470.	[bug]	Elements of the <code>isc_radix_node_t</code> could be incorrectly overwritten. [RT #18719]
2469.	[port]	solaris: Work around Solaris's <code>select()</code> limitations. [RT #18769]
2468.	[bug]	Resolver could try unreachable servers multiple times. [RT #18739]
2467.	[bug]	Failure of <code>fcntl(F_DUPFD)</code> wasn't logged. [RT #18740]
2466.	[doc]	ARM: explain <code>max-cache-ttl 0 SERVFAIL</code> issue. [RT #18302]
2465.	[bug]	Adb's handling of lame addresses was different for IPv4 and IPv6. [RT #18738]
2464.	[port]	linux: check that a capability is present before trying to set it. [RT #18135]
2463.	[port]	linux: POSIX doesn't include the IPv6 Advanced Socket API and glibc hides parts of the IPv6 Advanced Socket API as a result. This is stupid as it breaks how the two halves (Basic and Advanced) of the IPv6 Socket API were designed to be used but we have to live with it. Define <code>_GNU_SOURCE</code> to pull in the IPv6 Advanced Socket API. [RT #18388]
2462.	[doc]	Document <code>-m</code> (enable memory usage debugging) option for <code>dig</code> . [RT #18757]
2461.	[port]	sunos: Change #2363 was not complete. [RT #17513]

		--- 9.6.0a1 released ---
2460.	[bug]	Don't call <code>dns_db_getnsec3parameters()</code> on the cache. [RT #18697]
2459.	[contrib]	Import <code>dnssec-zkt</code> to <code>contrib/zkt</code> . [RT #18448]
2458.	[doc]	ARM: update and correction for <code>max-cache-size</code> . [RT #18294]
2457.	[tuning]	<code>max-cache-size</code> is reverted to 0, the previous default. It should be safe because expired cache entries are also purged. [RT #18684]
2456.	[bug]	In ACLs, <code>::/0</code> and <code>0.0.0.0/0</code> would both match any address, regardless of family. They now correctly distinguish IPv4 from IPv6. [RT #18559]

(continues on next page)

(continued from previous page)

- 2455. [bug] Stop metadata being transferred via axfr/ixfr.  
[RT #18639]
- 2454. [func] nsupdate: you can now set a default ttl. [RT #18317]
- 2453. [bug] Remove NULL pointer dereference in dns\_journal\_print().  
[RT #18316]
- 2452. [func] Improve bin/test/journalprint. [RT #18316]
- 2451. [port] solaris: handle runtime linking better. [RT #18356]
- 2450. [doc] Fix lwresd docbook problem for manual page.  
[RT #18672]
- 2449. [placeholder]
- 2448. [func] Add NSEC3 support. [RT #15452]
- 2447. [cleanup] libbind has been split out as a separate product.
- 2446. [func] Add a new log message about build options on startup.  
A new command-line option '-V' for named is also  
provided to show this information. [RT #18645]
- 2445. [doc] ARM out-of-date on empty reverse zones (list includes  
RFC1918 address, but these are not yet compiled in).  
[RT #18578]
- 2444. [port] Linux, FreeBSD, AIX: Turn off path mtu discovery  
(clear DF) for UDP responses and requests.
- 2443. [bug] win32: UDP connect() would not generate an event,  
and so connected UDP sockets would never clean up.  
Fix this by doing an immediate WSAConnect() rather  
than an io completion port type for UDP.
- 2442. [bug] A lock could be destroyed twice. [RT #18626]
- 2441. [bug] isc\_radix\_insert() could copy radix tree nodes  
incompletely. [RT #18573]
- 2440. [bug] named-checkconf used an incorrect test to determine  
if an ACL was set to none.
- 2439. [bug] Potential NULL dereference in dns\_acl\_isanyornone().  
[RT #18559]
- 2438. [bug] Timeouts could be logged incorrectly under win32.
- 2437. [bug] Sockets could be closed too early, leading to

(continues on next page)

(continued from previous page)

- inconsistent states in the socket module. [RT #18298]
- 2436. [security] win32: UDP client handler can be shutdown. [RT #18576]
- 2435. [bug] Fixed an ACL memory leak affecting win32.
- 2434. [bug] Fixed a minor error-reporting bug in lib/isc/win32/socket.c.
- 2433. [tuning] Set initial timeout to 800ms.
- 2432. [bug] More Windows socket handling improvements. Stop using I/O events and use IO Completion Ports throughout. Rewrite the receive path logic to make it easier to support multiple simultaneous requesters in the future. Add stricter consistency checking as a compile-time option (define ISC\_SOCKET\_CONSISTENCY\_CHECKS; defaults to off).
- 2431. [bug] Acl processing could leak memory. [RT #18323]
- 2430. [bug] win32: isc\_interval\_set() could round down to zero if the input was less than NS\_INTERVAL nanoseconds. Round up instead. [RT #18549]
- 2429. [doc] nsupdate should be in section 1 of the man pages. [RT #18283]
- 2428. [bug] dns\_iptable\_merge() mishandled merges of negative tables. [RT #18409]
- 2427. [func] Treat DNSKEY queries as if "minimal-response yes;" was set. [RT #18528]
- 2426. [bug] libbind: inet\_net\_pton() can sometimes return the wrong value if excessively large net masks are supplied. [RT #18512]
- 2425. [bug] named didn't detect unavailable query source addresses at load time. [RT #18536]
- 2424. [port] configure now probes for a working epoll implementation. Allow the use of kqueue, epoll and /dev/poll to be selected at compile time. [RT #18277]
- 2423. [security] Randomize server selection on queries, so as to make forgery a little more difficult. Instead of always preferring the server with the lowest RTT, pick a server with RTT within the same 128 millisecond band. [RT #18441]

(continues on next page)

(continued from previous page)

- 2422. [bug] Handle the special return value of a empty node as if it was a NXRRSET in the validator. [RT #18447]
- 2421. [func] Add new command line option '-S' for named to specify the max number of sockets. [RT #18493]  
Use caution: this option may not work for some operating systems without rebuilding named.
- 2420. [bug] Windows socket handling cleanup. Let the io completion event send out canceled read/write done events, which keeps us from writing to memory we no longer have ownership of. Add debugging socket\_log() function. Rework TCP socket handling to not leak sockets.
- 2419. [cleanup] Document that isc\_socket\_create() and isc\_socket\_open() should not be used for isc\_sockettype\_fdwatch sockets. [RT #18521]
- 2418. [bug] AXFR request on a DLZ could trigger a REQUIRE failure [RT #18430]
- 2417. [bug] Connecting UDP sockets for outgoing queries could unexpectedly fail with an 'address already in use' error. [RT #18411]
- 2416. [func] Log file descriptors that cause exceeding the internal maximum. [RT #18460]
- 2415. [bug] 'rndc dumpdb' could trigger various assertion failures in rbtodb.c. [RT #18455]
- 2414. [bug] A masterdump context held the database lock too long, causing various troubles such as dead lock and recursive lock acquisition. [RT #18311, #18456]
- 2413. [bug] Fixed an unreachable code path in socket.c. [RT #18442]
- 2412. [bug] win32: address a resource leak. [RT #18374]
- 2411. [bug] Allow using a larger number of sockets than FD\_SETSIZE for select(). To enable this, set ISC\_SOCKET\_MAXSOCKETS at compilation time. [RT #18433]  
  
Note: with changes #2469 and #2421 above, there is no need to tweak ISC\_SOCKET\_MAXSOCKETS at compilation time any more.
- 2410. [bug] Correctly delete m\_versionInfo. [RT #18432]
- 2409. [bug] Only log that we disabled EDNS processing if we were subsequently successful. [RT #18029]

(continues on next page)

(continued from previous page)

- 2408. [bug] A duplicate TCP dispatch event could be sent, which could then trigger an assertion failure in `resquery_response()`. [RT #18275]
- 2407. [port] `hpux`: test for `sys/dyntune.h`. [RT #18421]
- 2406. [placeholder]
- 2405. [cleanup] The default value for `dnssec-validation` was changed to "yes" in 9.5.0-P1 and all subsequent releases; this was inadvertently omitted from CHANGES at the time.
- 2404. [port] `hpux`: files unlimited support.
- 2403. [bug] TSIG context leak. [RT #18341]
- 2402. [port] Support Solaris 2.11 and over. [RT #18362]
- 2401. [bug] Expect to get `E[MN]FILE` `errno` `internal_accept()` (from `accept()` or `fcntl()` system calls). [RT #18358]
- 2400. [bug] Log if `kqueue()/epoll_create()/open(/dev/poll)` fails. [RT #18297]
- 2399. [placeholder]
- 2398. [bug] Improve file descriptor management. New, temporary, `named.conf` option `reserved-sockets`, default 512. [RT #18344]
- 2397. [bug] `gssapi_functions` had too many elements. [RT #18355]
- 2396. [bug] Don't set `SO_REUSEADDR` for randomized ports. [RT #18336]
- 2395. [port] Avoid warning and no effect from "files unlimited" on Linux when running as root. [RT #18335]
- 2394. [bug] Default configuration options set the limit for open files to 'unlimited' as described in the documentation. [RT #18331]
- 2393. [bug] nested acls containing keys could trigger an assertion in `acl.c`. [RT #18166]
- 2392. [bug] remove 'grep -q' from `acl` test script, some platforms don't support it. [RT #18253]
- 2391. [port] `hpux`: cover additional `recvmsg()` error codes. [RT #18301]

(continues on next page)

(continued from previous page)

- 2390. [bug] dispatch.c could make a false warning on 'odd socket'. [RT #18301].
- 2389. [bug] Move the "working directory writable" check to after the ns\_os\_changeuser() call. [RT #18326]
- 2388. [bug] Avoid using tables for layout purposes in statistics XSL [RT #18159].
- 2387. [bug] Silence compiler warnings in lib/isc/radix.c. [RT #18147] [RT #18258]
- 2386. [func] Add warning about too small 'open files' limit. [RT #18269]
- 2385. [bug] A condition variable in socket.c could leak in rare error handling [RT #17968].
- 2384. [security] Fully randomize UDP query ports to improve forgery resilience. [RT #17949, #18098]
- 2383. [bug] named could double queries when they resulted in SERVFAIL due to overkilling EDNS0 failure detection. [RT #18182]
- 2382. [doc] Add descriptions of DHCID, IPSECKEY, SPF and SSHFP to ARM.
- 2381. [port] dlz/mysql: support multiple install layouts for mysql. <prefix>/include/{,mysql/}mysql.h and <prefix>/lib/{,mysql/}. [RT #18152]
- 2380. [bug] dns\_view\_find() was not returning NXDOMAIN/NXRRSET proofs which, in turn, caused validation failures for insecure zones immediately below a secure zone the server was authoritative for. [RT #18112]
- 2379. [contrib] queryperf/gen-data-queryperf.py: removed redundant TLDs and supported RRs with TTLs [RT #17972]
- 2378. [bug] gssapi\_functions{} had a redundant member in BIND 9.5. [RT #18169]
- 2377. [bug] Address race condition in dnssec-signzone. [RT #18142]
- 2376. [bug] Change #2144 was not complete.
- 2375. [placeholder]
- 2374. [bug] "blackhole" ACLs could cause named to segfault due to some uninitialized memory. [RT #18095]

(continues on next page)

(continued from previous page)

- 2373. [bug] Default values of zone ACLs were re-parsed each time a new zone was configured, causing an overconsumption of memory. [RT #18092]
- 2372. [bug] Fixed incorrect TAG\_HMACSHA256\_BITS value [RT #18047]
- 2371. [doc] Add +nsid option to dig man page. [RT #18039]
- 2370. [bug] "rndc freeze" could trigger an assertion in named when called on a nonexistent zone. [RT #18050]
- 2369. [bug] libbind: Array bounds overrun on read in bitncmp(). [RT #18054]
- 2368. [port] Linux: use libcap for capability management if possible. [RT #18026]
- 2367. [bug] Improve counting of dns\_resstatscounter\_retry [RT #18030]
- 2366. [bug] Adb shutdown race. [RT #18021]
- 2365. [bug] Fix a bug that caused dns\_acl\_isany() to return spurious results. [RT #18000]
- 2364. [bug] named could trigger a assertion when serving a malformed signed zone. [RT #17828]
- 2363. [port] sunos: pre-set "lt\_cv\_sys\_max\_cmd\_len=4096;". [RT #17513]
- 2362. [cleanup] Make "rrset-order fixed" a compile-time option. settable by "./configure --enable-fixed-rrset". Disabled by default. [RT #17977]
- 2361. [bug] "recursion" statistics counter could be counted multiple times for a single query. [RT #17990]
- 2360. [bug] Fix a condition where we release a database version (which may acquire a lock) while holding the lock.
- 2359. [bug] Fix NSID bug. [RT #17942]
- 2358. [doc] Update host's default query description. [RT #17934]
- 2357. [port] Don't use OpenSSL's engine support in versions before OpenSSL 0.9.7f. [RT #17922]
- 2356. [bug] Built in mutex profiler was not scalable enough. [RT #17436]
- 2355. [func] Extend the number statistics counters available.

(continues on next page)

(continued from previous page)

		[RT #17590]
2354.	[bug]	Failed to initialize some rdatasetheader_t elements. [RT #17927]
2353.	[func]	Add support for Name Server ID (RFC 5001). 'dig +nsid' requests NSID from server. 'request-nsid yes;' causes recursive server to send NSID requests to upstream servers. Server responds to NSID requests with the string configured by 'server-id' option. [RT #17091]
2352.	[bug]	Various GSS_API fixups. [RT #17729]
2351.	[bug]	convertxsl.pl generated very long lines. [RT #17906]
2350.	[port]	win32: IPv6 support. [RT #17797]
2349.	[func]	Provide incremental re-signing support for secure dynamic zones. [RT #1091]
2348.	[func]	Use the EVP interface to OpenSSL. Add PKCS#11 support. Documentation is in the new README.pkcs11 file. New tool, dnssec-keyfromlabel, which takes the label of a key pair in a HSM and constructs a DNS key pair for use by named and dnssec-signzone. [RT #16844]
2347.	[bug]	Delete now traverses the RB tree in the canonical order. [RT #17451]
2346.	[func]	Memory statistics now cover all active memory contexts in increased detail. [RT #17580]
2345.	[bug]	named-checkconf failed to detect when forwarders were set at both the options/view level and in a root zone. [RT #17671]
2344.	[bug]	Improve "logging{ file ...; };" documentation. [RT #17888]
2343.	[bug]	(Seemingly) duplicate IPv6 entries could be created in ADB. [RT #17837]
2342.	[func]	Use getifaddrs() if available under Linux. [RT #17224]
2341.	[bug]	libbind: add missing -I../include for off source tree builds. [RT #17606]
2340.	[port]	openbsd: interface configuration. [RT #17700]
2339.	[port]	tru64: support for libbind. [RT #17589]

(continues on next page)

(continued from previous page)

- 2338. [bug] check\_ds() could be called with a non DS rdataset.  
[RT #17598]
- 2337. [bug] BUILD\_LDFLAGS was not being correctly set. [RT #17614]
- 2336. [func] If "named -6" is specified then listen on all IPv6  
interfaces if there are not listen-on-v6 clauses in  
named.conf. [RT #17581]
- 2335. [port] sunos: libbind and \*printf() support for long long.  
[RT #17513]
- 2334. [bug] Bad REQUIRES in fromstruct\_in\_naptr(), off by one  
bug in fromstruct\_txt(). [RT #17609]
- 2333. [bug] Fix off by one error in isc\_time\_nowplusinterval().  
[RT #17608]
- 2332. [contrib] query-loc-0.4.0. [RT #17602]
- 2331. [bug] Failure to regenerate any signatures was not being  
reported nor being past back to the UPDATE client.  
[RT #17570]
- 2330. [bug] Remove potential race condition when handling  
over memory events. [RT #17572]  
  
WARNING: API CHANGE: over memory callback  
function now needs to call isc\_mem\_waterack().  
See <isc/mem.h> for details.
- 2329. [bug] Clearer help text for dig's '-x' and '-i' options.
- 2328. [maint] Add AAAA addresses for A.ROOT-SERVERS.NET,  
F.ROOT-SERVERS.NET, H.ROOT-SERVERS.NET,  
J.ROOT-SERVERS.NET, K.ROOT-SERVERS.NET and  
M.ROOT-SERVERS.NET.
- 2327. [bug] It was possible to dereference a NULL pointer in  
rbtdb.c. Implement dead node processing in zones as  
we do for caches. [RT #17312]
- 2326. [bug] It was possible to trigger a INSIST in the aCACHE  
processing.
- 2325. [port] Linux: use capset() function if available. [RT #17557]
- 2324. [bug] Fix IPv6 matching against "any;". [RT #17533]
- 2323. [port] tru64: namespace clash. [RT #17547]

(continues on next page)

(continued from previous page)

- 2322. [port] MacOS: work around the limitation of setrlimit() for RLIMIT\_NOFILE. [RT #17526]
- 2321. [placeholder]
- 2320. [func] Make statistics counters thread-safe for platforms that support certain atomic operations. [RT #17466]
- 2319. [bug] Silence Coverity warnings in lib/dns/rdata/in\_1/apl\_42.c. [RT #17469]
- 2318. [port] sunos fixes for libbind. [RT #17514]
- 2317. [bug] "make distclean" removed bind9.xsl.h. [RT #17518]
- 2316. [port] Missing #include <isc/print.h> in lib/dns/gssapictx.c. [RT #17513]
- 2315. [bug] Used incorrect address family for mapped IPv4 addresses in acl.c. [RT #17519]
- 2314. [bug] Uninitialized memory use on error path in bin/named/lwdnoop.c. [RT #17476]
- 2313. [cleanup] Silence Coverity warnings. Handle private stacks. [RT #17447] [RT #17478]
- 2312. [cleanup] Silence Coverity warning in lib/isc/unix/socket.c. [RT #17458]
- 2311. [bug] IPv6 addresses could match IPv4 ACL entries and vice versa. [RT #17462]
- 2310. [bug] dig, host, nslookup: flush stdout before emitting debug/fatal messages. [RT #17501]
- 2309. [cleanup] Fix Coverity warnings in lib/dns/acl.c and iptable.c. [RT #17455]
- 2308. [cleanup] Silence Coverity warning in bin/named/controlconf.c. [RT #17495]
- 2307. [bug] Remove infinite loop from lib/dns/sdb.c. [RT #17496]
- 2306. [bug] Remove potential race from lib/dns/resolver.c. [RT #17470]
- 2305. [security] inet\_network() buffer overflow. CVE-2008-0122.
- 2304. [bug] Check returns from all dns\_rdata\_tostruct() calls. [RT #17460]

(continues on next page)

(continued from previous page)

- 2303. [bug] Remove unnecessary code from bin/named/lwdgnba.c. [RT #17471]
- 2302. [bug] Fix memset() calls in lib/tests/t\_api.c. [RT #17472]
- 2301. [bug] Remove resource leak and fix error messages in bin/tests/system/lwresd/lwtest.c. [RT #17474]
- 2300. [bug] Fixed failure to close open file in bin/tests/names/t\_names.c. [RT #17473]
- 2299. [bug] Remove unnecessary NULL check in bin/nsupdate/nsupdate.c. [RT #17475]
- 2298. [bug] isc\_mutex\_lock() failure not caught in bin/tests/timers/t\_timers.c. [RT #17468]
- 2297. [bug] isc\_entropy\_createfilesources() failure not caught in bin/tests/dst/t\_dst.c. [RT #17467]
- 2296. [port] Allow docbook stylesheet location to be specified to configure. [RT #17457]
- 2295. [bug] Silence static overrun error in bin/named/lwaddr.c. [RT #17459]
- 2294. [func] Allow the experimental statistics channels to have multiple connections and ACL.  
Note: the stats-server and stats-server-v6 options available in the previous beta releases are replaced with the generic statistics-channels statement.
- 2293. [func] Add ACL regression test. [RT #17375]
- 2292. [bug] Log if the working directory is not writable. [RT #17312]
- 2291. [bug] PR\_SET\_DUMPABLE may be set too late. Also report failure to set PR\_SET\_DUMPABLE. [RT #17312]
- 2290. [bug] Let AD in the query signal that the client wants AD set in the response. [RT #17301]
- 2289. [func] named-checkzone now reports the out-of-zone CNAME found. [RT #17309]
- 2288. [port] win32: mark service as running when we have finished loading. [RT #17441]
- 2287. [bug] Use 'volatile' if the compiler supports it. [RT #17413]
- 2286. [func] Allow a TCP connection to be used as a weak

(continues on next page)

(continued from previous page)

		authentication method for reverse zones. New update-policy methods tcp-self and 6to4-self. [RT #17378]
2285.	[func]	Test framework for client memory context management. [RT #17377]
2284.	[bug]	Memory leak in UPDATE prerequisite processing. [RT #17377]
2283.	[bug]	TSIG keys were not attaching to the memory context. TSIG keys should use the rings memory context rather than the clients memory context. [RT #17377]
2282.	[bug]	Acl code fixups. [RT #17346] [RT #17374]
2281.	[bug]	Attempts to use undefined acls were not being logged. [RT #17307]
2280.	[func]	Allow the experimental http server to be reached over IPv6 as well as IPv4. [RT #17332]
2279.	[bug]	Use setsockopt(SO_NOSIGPIPE), when available, to protect applications from receiving spurious SIGPIPE signals when using the resolver.
2278.	[bug]	win32: handle the case where Windows returns no search list or DNS suffix. [RT #17354]
2277.	[bug]	Empty zone names were not correctly being caught at in the post parse checks. [RT #17357]
2276.	[bug]	Install <dst/gssapi.h>. [RT #17359]
2275.	[func]	Add support to dig to perform IXFR queries over UDP. [RT #17235]
2274.	[func]	Log zone transfer statistics. [RT #17336]
2273.	[bug]	Adjust log level to WARNING when saving inconsistent stub/slave master and journal files. [RT #17279]
2272.	[bug]	Handle illegal dnssec-lookaside trust-anchor names. [RT #17262]
2271.	[bug]	Fix a memory leak in http server code [RT #17100]
2270.	[bug]	dns_db_closeversion() version->writer could be reset before it is tested. [RT #17290]
2269.	[contrib]	dbus memory leaks and missing va_end calls. [RT #17232]

(continues on next page)

(continued from previous page)

2268. [bug] 0.IN-ADDR.ARPA was missing from the empty zones list.

--- 9.5.0b1 released ---

2267. [bug] Radix tree node\_num value could be set incorrectly, causing positive ACL matches to look like negative ones. [RT #17311]

2266. [bug] client.c:get\_clientmctx() returned the same mctx once the pool of mctx's was filled. [RT #17218]

2265. [bug] Test that the memory context's basic\_table is non NULL before freeing. [RT #17265]

2264. [bug] Server prefix length was being ignored. [RT #17308]

2263. [bug] "named-checkconf -z" failed to set default value for "check-integrity". [RT #17306]

2262. [bug] Error status from all but the last view could be lost. [RT #17292]

2261. [bug] Fix memory leak with "any" and "none" ACLs [RT #17272]

2260. [bug] Reported wrong clients-per-query when increasing the value. [RT #17236]

2259. [placeholder]

--- 9.5.0a7 released ---

2258. [bug] Fallback from IXFR/TSIG to SOA/AXFR/TSIG broken. [RT #17241]

2257. [bug] win32: Use the full path to vcredist\_x86.exe when calling it. [RT #17222]

2256. [bug] win32: Correctly register the installation location of bindevt.dll. [RT #17159]

2255. [maint] L.ROOT-SERVERS.NET is now 199.7.83.42.

2254. [bug] timer.c:dispatch() failed to lock timer->lock when reading timer->idle allowing it to see intermediate values as timer->idle was reset by isc\_timer\_touch(). [RT #17243]

2253. [func] "max-cache-size" defaults to 32M.  
"max-acache-size" defaults to 16M.

(continues on next page)

(continued from previous page)

- 2252. [bug] Fixed errors in sortlist code [RT #17216]
- 2251. [placeholder]
- 2250. [func] New flag 'memstatistics' to state whether the memory statistics file should be written or not. Additionally named's -m option will cause the statistics file to be written. [RT #17113]
- 2249. [bug] Only set Authentic Data bit if client requested DNSSEC, per RFC 3655 [RT #17175]
- 2248. [cleanup] Fix several errors reported by Coverity. [RT #17160]
- 2247. [doc] Sort doc/misc/options. [RT #17067]
- 2246. [bug] Make the startup of test servers (ans.pl) more robust. [RT #17147]
- 2245. [bug] Validating lack of DS records at trust anchors wasn't working. [RT #17151]
- 2244. [func] Allow the check of nameserver names against the SOA MNAME field to be disabled by specifying 'notify-to-soa yes;'. [RT #17073]
- 2243. [func] Configuration files without a newline at the end now parse without error. [RT #17120]
- 2242. [bug] nsupdate: GSS-TSIG support using the Heimdal Kerberos library could require a source of random data. [RT #17127]
- 2241. [func] nsupdate: add a interactive 'help' command. [RT #17099]
- 2240. [bug] Cleanup nsupdates GSS-TSIG support. Convert a number of INSIST()s into plain fatal() errors which report the triggering result code. The 'key' command wasn't disabling GSS-TSIG. [RT #17099]
- 2239. [func] Ship a pre built bin/named/bind9.xsl.h. [RT #17114]
- 2238. [bug] It was possible to trigger a REQUIRE when a validation was canceled. [RT #17106]
- 2237. [bug] libbind: res\_init() was not thread aware. [RT #17123]
- 2236. [bug] dnssec-signzone failed to preserve the case of of wildcard owner names. [RT #17085]

(continues on next page)

(continued from previous page)

- 2235. [bug] <isc/atomic.h> was not being installed. [RT #17135]
- 2234. [port] Correct some compiler warnings on SCO OSr5 [RT #17134]
- 2233. [func] Add support for O(1) ACL processing, based on radix tree code originally written by Kevin Brintnall. [RT #16288]
- 2232. [bug] dns\_adb\_findaddrinfo() could fail and return ISC\_R\_SUCCESS. [RT #17137]
- 2231. [bug] Building dlzbdb (contrib/dlz/bin/dlzbdb) was broken. [RT #17088]
- 2230. [bug] We could INSIST reading a corrupted journal. [RT #17132]
- 2229. [bug] Null pointer dereference on query pool creation failure. [RT #17133]
- 2228. [contrib] contrib: Change 2188 was incomplete.
- 2227. [cleanup] Tidied up the FAQ. [RT #17121]
- 2226. [placeholder]
- 2225. [bug] More support for systems with no IPv4 addresses. [RT #17111]
- 2224. [bug] Defer journal compaction if a xfrin is in progress. [RT #17119]
- 2223. [bug] Make a new journal when compacting. [RT #17119]
- 2222. [func] named-checkconf now checks server key references. [RT #17097]
- 2221. [bug] Set the event result code to reflect the actual record turned to caller when a cache update is rejected due to a more credible answer existing. [RT #17017]
- 2220. [bug] win32: Address a race condition in final shutdown of the Windows socket code. [RT #17028]
- 2219. [bug] Apply zone consistency checks to additions, not removals, when updating. [RT #17049]
- 2218. [bug] Remove unnecessary REQUIRE from dns\_validator\_create(). [RT #16976]
- 2217. [func] Adjust update log levels. [RT #17092]

(continues on next page)

(continued from previous page)

- 2216. [cleanup] Fix a number of errors reported by Coverity.  
[RT #17094]
- 2215. [bug] Bad REQUIRE check isc\_hmacsha1\_verify(). [RT #17094]
- 2214. [bug] Deregister OpenSSL lock callback when cleaning up. Reorder OpenSSL cleanup so that RAND\_cleanup() is called before the locks are destroyed. [RT #17098]
- 2213. [bug] SIG0 diagnostic failure messages were looking at the wrong status code. [RT #17101]
- 2212. [func] 'host -m' now causes memory statistics and active memory to be printed at exit. [RT 17028]
- 2211. [func] Update "dynamic update temporarily disabled" message. [RT #17065]
- 2210. [bug] Deleting class specific records via UPDATE could fail. [RT #17074]
- 2209. [port] osx: linking against user supplied static OpenSSL libraries failed as the system ones were still being found. [RT #17078]
- 2208. [port] win32: make sure both build methods produce the same output. [RT #17058]
- 2207. [port] Some implementations of getaddrinfo() fail to set ai\_canonname correctly. [RT #17061]

--- 9.5.0a6 released ---

- 2206. [security] "allow-query-cache" and "allow-recursion" now cross inherit from each other.  
  
If allow-query-cache is not set in named.conf then allow-recursion is used if set, otherwise allow-query is used if set, otherwise the default (localnets; localhost;) is used.  
  
If allow-recursion is not set in named.conf then allow-query-cache is used if set, otherwise allow-query is used if set, otherwise the default (localnets; localhost;) is used.  
  
[RT #16987]
- 2205. [bug] libbind: change #2119 broke thread support. [RT #16982]
- 2204. [bug] "rndc flushname name unknown-view" caused named

(continues on next page)

(continued from previous page)

		to crash. [RT #16984]
2203.	[security]	Query id generation was cryptographically weak. [RT # 16915]
2202.	[security]	The default acls for allow-query-cache and allow-recursion were not being applied. [RT #16960]
2201.	[bug]	The build failed in a separate object directory. [RT #16943]
2200.	[bug]	The search for cached NSEC records was stopping to early leading to excessive DLV queries. [RT #16930]
2199.	[bug]	win32: don't call WSASStartup() while loading dlls. [RT #16911]
2198.	[bug]	win32: RegCloseKey() could be called when RegOpenKeyEx() failed. [RT #16911]
2197.	[bug]	Add INSIST to catch negative responses which are not setting the event result code appropriately. [RT #16909]
2196.	[port]	win32: yield processor while waiting for once to to complete. [RT #16958]
2195.	[func]	dnssec-keygen now defaults to nametype "ZONE" when generating DNSKEYs. [RT #16954]
2194.	[bug]	Close journal before calling 'done' in xfrin.c.

		--- 9.5.0a5 released ---
2193.	[port]	win32: BINDInstall.exe is now linked statically. [RT #16906]
2192.	[port]	win32: use vcredist_x86.exe to install Visual Studio's redistributable dlls if building with Visual Stdio 2005 or later.
2191.	[func]	named-checkzone now allows dumping to stdout (-). named-checkconf now has -h for help. named-checkzone now has -h for help. rndc now has -h for help. Better handling of '-?' for usage summaries. [RT #16707]
2190.	[func]	Make fallback to plain DNS from EDNS due to timeouts more visible. New logging category "edns-disabled". [RT #16871]

(continues on next page)

(continued from previous page)

2189.	[bug]	Handle socket() returning EINTR. [RT #15949]
2188.	[contrib]	queryperf: autoconf changes to make the search for libresolv or libbind more robust. [RT #16299]
2187.	[bug]	query_addds(), query_addwildcardproof() and query_addnrrsetnsec() should take a version argument. [RT #16368]
2186.	[port]	cygwin: libbind: check for struct sockaddr_storage independently of IPv6. [RT #16482]
2185.	[port]	sunos: libbind: check for ssize_t, memmove() and memchr(). [RT #16463]
2184.	[bug]	bind9.xsl.h didn't build out of the source tree. [RT #16830]
2183.	[bug]	dnssec-signzone didn't handle offline private keys well. [RT #16832]
2182.	[bug]	dns_dispatch_createtcp() and dispatch_createudp() could return ISC_R_SUCCESS when they ran out of memory. [RT #16365]
2181.	[port]	sunos: libbind: add paths.h from BIND 8. [RT #16462]
2180.	[cleanup]	Remove bit test from 'compress_test' as they are no longer needed. [RT #16497]
2179.	[func]	'rndc command zone' will now find 'zone' if it is unique to all the views. [RT #16821]
2178.	[bug]	'rndc reload' of a slave or stub zone resulted in a reference leak. [RT #16867]
2177.	[bug]	Array bounds overrun on read (rcodetext) at debug level 10+. [RT #16798]
2176.	[contrib]	dbus update to handle race condition during initialization (Bugzilla 235809). [RT #16842]
2175.	[bug]	win32: windows broadcast condition variable support was broken. [RT #16592]
2174.	[bug]	I/O errors should always be fatal when reading master files. [RT #16825]
2173.	[port]	win32: When compiling with MSVS 2005 SP1 we also need to ship Microsoft.VC80.MFCLOC.

--- 9.5.0a4 released ---

- 2172. [bug] query\_addsoa() was being called with a non zone db.  
[RT #16834]
- 2171. [bug] Handle breaks in DNSSEC trust chains where the parent servers are not DS aware (DS queries to the parent return a referral to the child).
- 2170. [func] Add acache processing to test suite. [RT #16711]
- 2169. [bug] host, nslookup: when reporting NXDOMAIN report the given name and not the last name searched for.  
[RT #16763]
- 2168. [bug] nsupdate: in non-interactive mode treat syntax errors as fatal errors. [RT #16785]
- 2167. [bug] When re-using a automatic zone named failed to attach it to the new view. [RT #16786]

--- 9.5.0a3 released ---

- 2166. [bug] When running in batch mode, dig could misinterpret a server address as a name to be looked up, causing unexpected output. [RT #16743]
- 2165. [func] Allow the destination address of a query to determine if we will answer the query or recurse.  
allow-query-on, allow-recursion-on and allow-query-cache-on. [RT #16291]
- 2164. [bug] The code to determine how named-checkzone / named-compilezone was called failed under windows.  
[RT #16764]
- 2163. [bug] If only one of query-source and query-source-v6 specified a port the query pools code broke (change 2129). [RT #16768]
- 2162. [func] Allow "rrset-order fixed" to be disabled at compile time. [RT #16665]
- 2161. [bug] Fix which log messages are emitted for 'rndc flush'.  
[RT #16698]
- 2160. [bug] libisc wasn't handling NULL ifa\_addr pointers returned from getifaddrs(). [RT #16708]

--- 9.5.0a2 released ---

- 2159. [bug] Array bounds overrun in acache processing. [RT #16710]

(continues on next page)

(continued from previous page)

- 2158. [bug] ns\_client\_isself() failed to initialize key leading to a REQUIRE failure. [RT #16688]
- 2157. [func] dns\_db\_transfernote() created. [RT #16685]
- 2156. [bug] Fix node reference leaks in lookup.c:lookup\_find(), resolver.c:validated() and resolver.c:cache\_name(). Fix a memory leak in rbtodb.c:free\_noqname(). Make lookup.c:lookup\_find() robust against event leaks. [RT #16685]
- 2155. [contrib] SQLite sdb module from jaboydjr@netwalk.com. [RT #16694]
- 2154. [func] Scoped (e.g. IPv6 link-local) addresses may now be matched in acls by omitting the scope. [RT #16599]
- 2153. [bug] nsupdate could leak memory. [RT #16691]
- 2152. [cleanup] Use sizeof(buf) instead of fixed number in dighost.c:get\_trusted\_key(). [RT #16678]
- 2151. [bug] Missing newline in usage message for journalprint. [RT #16679]
- 2150. [bug] 'rrset-order cyclic' uniformly distribute the starting point for the first response for a given RRset. [RT #16655]
- 2149. [bug] isc\_mem\_checkdestroyed() failed to abort on if there were still active memory contexts. [RT #16672]
- 2148. [func] Add positive logging for rndc commands. [RT #14623]
- 2147. [bug] libbind: remove potential buffer overflow from hmac\_link.c. [RT #16437]
- 2146. [cleanup] Silence Linux's spurious "obsolete setsockopt SO\_BSDCOMPAT" message. [RT #16641]
- 2145. [bug] Check DS/DLV digest lengths for known digests. [RT #16622]
- 2144. [cleanup] Suppress logging of SERVFAIL from forwarders. [RT #16619]
- 2143. [bug] We failed to restart the IPv6 client when the kernel failed to return the destination the packet was sent to. [RT #16613]

(continues on next page)

(continued from previous page)

2142.	[bug]	Handle master files with a modification time that matches the epoch. [RT #16612]
2141.	[bug]	dig/host should not be setting IDN_ASCCHECK (IDN equivalent of LDH checks). [RT #16609]
2140.	[bug]	libbind: missing unlock on pthread_key_create() failures. [RT #16654]
2139.	[bug]	dns_view_find() was being called with wrong type in adb.c. [RT #16670]
2138.	[bug]	Lock order reversal in resolver.c. [RT #16653]
2137.	[port]	Mips little endian and/or mips 64 bit are now supported for atomic operations. [RT #16648]
2136.	[bug]	nslookup/host looped if there was no search list and the host didn't exist. [RT #16657]
2135.	[bug]	Uninitialized rdataset in sdlz.c. [RT #16656]
2134.	[func]	Additional statistics support. [RT #16666]
2133.	[port]	powerpc: Support both IBM and MacOS Power PC assembler syntaxes. [RT #16647]
2132.	[bug]	Missing unlock on out of memory in dns_dispatchmgr_setudp().
2131.	[contrib]	dlz/mysql: AXFR was broken. [RT #16630]
2130.	[func]	Log if CD or DO were set. [RT #16640]
2129.	[func]	Provide a pool of UDP sockets for queries to be made over. See use-queryport-pool, queryport-pool-ports and queryport-pool-updateinterval. [RT #16415]
2128.	[doc]	xsltproc --nonet, update DTD versions. [RT #16635]
2127.	[port]	Improved OpenSSL 0.9.8 support. [RT #16563]
2126.	[security]	Serialize validation of type ANY responses. [RT #16555]
2125.	[bug]	dns_zone_getzeronosattl() REQUIRE failure if DLZ was defined. [RT #16574]
2124.	[security]	It was possible to dereference a freed fetch context. [RT #16584]

--- 9.5.0a1 released ---

(continues on next page)

(continued from previous page)

- 2123. [func] Use Doxygen to generate internal documentation.  
[RT #11398]
- 2122. [func] Experimental http server and statistics support  
for named via xml.
- 2121. [func] Add a 10 slot dead masters cache (LRU) with a 600  
second timeout. [RT #16553]
- 2120. [doc] Fix markup on nsupdate man page. [RT #16556]
- 2119. [compat] libbind: allow res\_init() to succeed enough to  
return the default domain even if it was unable  
to allocate memory.
- 2118. [bug] Handle response with long chains of domain name  
compression pointers which point to other compression  
pointers. [RT #16427]
- 2117. [bug] DNSSEC fixes: named could fail to cache NSEC records  
which could lead to validation failures. named didn't  
handle negative DS responses that were in the process  
of being validated. Check CNAME bit before accepting  
NODATA proof. To be able to ignore a child NSEC there  
must be SOA (and NS) set in the bitmap. [RT #16399]
- 2116. [bug] 'rndc reload' could cause the cache to continually  
be cleaned. [RT #16401]
- 2115. [bug] 'rndc reconfig' could trigger a INSIST if the  
number of masters for a zone was reduced. [RT #16444]
- 2114. [bug] dig/host/nslookup: searches for names with multiple  
labels were failing. [RT #16447]
- 2113. [bug] nsupdate: if a zone is specified it should be used  
for server discover. [RT #16455]
- 2112. [security] Warn if weak RSA exponent is used. [RT #16460]
- 2111. [bug] Fix a number of errors reported by Coverity.  
[RT #16507]
- 2110. [bug] "minimal-responses yes;" interacted badly with BIND 8  
priming queries. [RT #16491]
- 2109. [port] libbind: silence aix 5.3 compiler warnings. [RT #16502]
- 2108. [func] DHCID support. [RT #16456]
- 2107. [bug] dighost.c: more cleanup of buffers. [RT #16499]

(continues on next page)

(continued from previous page)

- 2106. [func] 'rndc status' now reports named's version. [RT #16426]
- 2105. [func] GSS-TSIG support (RFC 3645).
- 2104. [port] Fix Solaris SMF error message.
- 2103. [port] Add /usr/sfw to list of locations for OpenSSL under Solaris.
- 2102. [port] Silence Solaris 10 warnings.
- 2101. [bug] OpenSSL version checks were not quite right. [RT #16476]
- 2100. [port] win32: copy libeay32.dll to Build\Debug. Copy Debug\named-checkzone to Debug\named-compilezone.
- 2099. [port] win32: more manifest issues.
- 2098. [bug] Race in rbtodb.c:no\_references(), which occasionally triggered an INSIST failure about the node lock reference. [RT #16411]
- 2097. [bug] named could reference a destroyed memory context after being reloaded / reconfigured. [RT #16428]
- 2096. [bug] libbind: handle applications that fail to detect res\_init() failures better.
- 2095. [port] libbind: always prototype inet\_cidr\_ntop\_ipv6() and net\_cidr\_ntop\_ipv6(). [RT #16388]
- 2094. [contrib] Update named-bootconf. [RT #16404]
- 2093. [bug] named-checkzone -s was broken.
- 2092. [bug] win32: dig, host, nslookup. Use registry config if resolv.conf does not exist or no nameservers listed. [RT #15877]
- 2091. [port] dighost.c: race condition on cleanup. [RT #16417]
- 2090. [port] win32: Visual C++ 2005 command line manifest support. [RT #16417]
- 2089. [security] Raise the minimum safe OpenSSL versions to OpenSSL 0.9.7l and OpenSSL 0.9.8d. Versions prior to these have known security flaws which are (potentially) exploitable in named. [RT #16391]
- 2088. [security] Change the default RSA exponent from 3 to 65537. [RT #16391]

(continues on next page)

(continued from previous page)

- 2087. [port] libisc failed to compile on OS's w/o a vsnprintf.  
[RT #16382]
- 2086. [port] libbind: FreeBSD now has get\*by\*\_r() functions.  
[RT #16403]
- 2085. [doc] win32: added index.html and README to zip. [RT #16201]
- 2084. [contrib] dbus update for 9.3.3rc2.
- 2083. [port] win32: Visual C++ 2005 support.
- 2082. [doc] Document 'cache-file' as a test only option.
- 2081. [port] libbind: minor 64-bit portability fix in memcluster.c.  
[RT #16360]
- 2080. [port] libbind: res\_init.c did not compile on older versions  
of Solaris. [RT #16363]
- 2079. [bug] The lame cache was not handling multiple types  
correctly. [RT #16361]
- 2078. [bug] dnssec-checkzone output style "default" was badly  
named. It is now called "relative". [RT #16326]
- 2077. [bug] 'dnssec-signzone -O raw' wasn't outputting the  
complete signed zone. [RT #16326]
- 2076. [bug] Several files were missing #include <config.h>  
causing build failures on OSF. [RT #16341]
- 2075. [bug] The spillat timer event handler could leak memory.  
[RT #16357]
- 2074. [bug] dns\_request\_createvia2(), dns\_request\_createvia3(),  
dns\_request\_createraw2() and dns\_request\_createraw3()  
failed to send multiple UDP requests. [RT #16349]
- 2073. [bug] Incorrect semantics check for update policy "wildcard".  
[RT #16353]
- 2072. [bug] We were not generating valid HMAC SHA digests.  
[RT #16320]
- 2071. [port] Test whether gcc accepts -fno-strict-aliasing.  
[RT #16324]
- 2070. [bug] The remote address was not always displayed when  
reporting dispatch failures. [RT #16315]

(continues on next page)

(continued from previous page)

- 2069. [bug] Cross compiling was not working. [RT #16330]
- 2068. [cleanup] Lower incremental tuning message to debug 1.  
[RT #16319]
- 2067. [bug] 'rndc' could close the socket too early triggering  
a INSIST under Windows. [RT #16317]
- 2066. [security] Handle SIG queries gracefully. [RT #16300]
- 2065. [bug] libbind: probe for HPUX prototypes for  
endprotoent\_r() and endservent\_r(). [RT 16313]
- 2064. [bug] libbind: silence AIX compiler warnings. [RT #16218]
- 2063. [bug] Change #1955 introduced a bug which caused the first  
'rndc flush' call to not free memory. [RT #16244]
- 2062. [bug] 'dig +nssearch' was reusing a buffer before it had  
been returned by the socket code. [RT #16307]
- 2061. [bug] Accept expired wildcard message reversed. [RT #16296]
- 2060. [bug] Enabling DLZ support could leave views partially  
configured. [RT #16295]
- 2059. [bug] Search into cache rbtodb could trigger an INSIST  
failure while cleaning up a stale rdataset.  
[RT #16292]
- 2058. [bug] Adjust how we calculate rtt estimates in the presence  
of authoritative servers that drop EDNS and/or CD  
requests. Also fallback to EDNS/512 and plain DNS  
faster for zones with less than 3 servers. [RT #16187]
- 2057. [bug] Make setting "ra" dependent on both allow-query-cache  
and allow-recursion. [RT #16290]
- 2056. [bug] dig: ixfr= was not being treated case insensitively  
at all times. [RT #15955]
- 2055. [bug] Missing goto after dropping multicast query.  
[RT #15944]
- 2054. [port] freebsd: do not explicitly link against -lpthread.  
[RT #16170]
- 2053. [port] netbsd:libbind: silence compiler warnings. [RT #16220]
- 2052. [bug] 'rndc' improve connect failed message to report  
the failing address. [RT #15978]

(continues on next page)

(continued from previous page)

2051.	[port]	More strtol() fixes. [RT #16249]
2050.	[bug]	Parsing of NSAP records was not case insensitive. [RT #16287]
2049.	[bug]	Restore SOA before AXFR when falling back from a attempted IXFR when transferring in a zone. Allow a initial SOA query before attempting a AXFR to be requested. [RT #16156]
2048.	[bug]	It was possible to loop forever when using avoid-v4-udp-ports / avoid-v6-udp-ports when the OS always returned the same local port. [RT #16182]
2047.	[bug]	Failed to initialize the interface flags to zero. [RT #16245]
2046.	[bug]	rbtdb.c:rdataset_setadditional() could cause duplicate cleanup [RT #16247].
2045.	[func]	Use lock buckets for acache entries to limit memory consumption. [RT #16183]
2044.	[port]	Add support for atomic operations for Itanium. [RT #16179]
2043.	[port]	nsupdate/nslookup: Force the flushing of the prompt for interactive sessions. [RT #16148]
2042.	[bug]	named-checkconf was incorrectly rejecting the logging category "config". [RT #16117]
2041.	[bug]	"configure --with-dlz-bdb=yes" produced a bad set of libraries to be linked. [RT #16129]
2040.	[bug]	rbtdb no_references() could trigger an INSIST failure with --enable-atomic. [RT #16022]
2039.	[func]	Check that all buffers passed to the socket code have been retrieved when the socket event is freed. [RT #16122]
2038.	[bug]	dig/nslookup/host was unlinking from wrong list when handling errors. [RT #16122]
2037.	[func]	When unlinking the first or last element in a list check that the list head points to the element to be unlinked. [RT #15959]
2036.	[bug]	'rndc recursing' could cause trigger a REQUIRE. [RT #16075]

(continues on next page)

(continued from previous page)

- 2035. [func] Make falling back to TCP on UDP refresh failure optional. Default "try-tcp-refresh yes;" for BIND 8 compatibility. [RT #16123]
- 2034. [bug] gcc: set -fno-strict-aliasing. [RT #16124]
- 2033. [bug] We weren't creating multiple client memory contexts on demand as expected. [RT #16095]
- 2032. [bug] Remove a INSIST in query\_addadditional2(). [RT #16074]
- 2031. [bug] Emit a error message when "rndc refresh" is called on a non slave/stub zone. [RT # 16073]
- 2030. [bug] We were being overly conservative when disabling openssl engine support. [RT #16030]
- 2029. [bug] host printed out the server multiple times when specified on the command line. [RT #15992]
- 2028. [port] linux: socket.c compatibility for old systems. [RT #16015]
- 2027. [port] libbind: Solaris x86 support. [RT #16020]
- 2026. [bug] Rate limit the two recursive client exceeded messages. [RT #16044]
- 2025. [func] Update "zone serial unchanged" message. [RT #16026]
- 2024. [bug] named emitted spurious "zone serial unchanged" messages on reload. [RT #16027]
- 2023. [bug] "make install" should create \${localstatedir}/run and \${sysconfdir} if they do not exist. [RT #16033]
- 2022. [bug] If dnssec validation is disabled only assert CD if CD was requested. [RT #16037]
- 2021. [bug] dnssec-enable no; triggered a REQUIRE. [RT #16037]
- 2020. [bug] rdataset\_setadditional() could leak memory. [RT #16034]
- 2019. [tuning] Reduce the amount of work performed per quantum when cleaning the cache. [RT #15986]
- 2018. [bug] Checking if the HMAC MD5 private file was broken. [RT #15960]
- 2017. [bug] allow-query default was not correct. [RT #15946]

(continues on next page)

(continued from previous page)

2016.	[bug]	Return a partial answer if recursion is not allowed but requested and we had the answer to the original qname. [RT #15945]
2015.	[cleanup]	use-additional-cache is now acache-enable for consistency. Default acache-enable off in BIND 9.4 as it requires memory usage to be configured. It may be enabled by default in BIND 9.5 once we have more experience with it.
2014.	[func]	Statistics about acache now recorded and sent to log. [RT #15976]
2013.	[bug]	Handle unexpected TSIGs on unsigned AXFR/IXFR responses more gracefully. [RT #15941]
2012.	[func]	Don't insert new acache entries if acache is full. [RT #15970]
2011.	[func]	dnssec-signzone can now update the SOA record of the signed zone, either as an increment or as the system time(). [RT #15633]
2010.	[placeholder]	rt15958
2009.	[bug]	libbind: Coverity fixes. [RT #15808]
2008.	[func]	It is now possible to enable/disable DNSSEC validation from rndc. This is useful for the mobile hosts where the current connection point breaks DNSSEC (firewall/proxy). [RT #15592]
		rndc validation newstate [view]
2007.	[func]	It is now possible to explicitly enable DNSSEC validation. default dnssec-validation no; to be changed to yes in 9.5.0. [RT #15674]
2006.	[security]	Allow-query-cache and allow-recursion now default to the built in acls "localnets" and "localhost".
		This is being done to make caching servers less attractive as reflective amplifying targets for spoofed traffic. This still leave authoritative servers exposed.
		The best fix is for full BCP 38 deployment to remove spoofed traffic.
2005.	[bug]	libbind: Retransmission timeouts should be based on which attempt it is to the nameserver and not the nameserver itself. [RT #13548]

(continues on next page)

(continued from previous page)

- 2004. [bug] dns\_tsig\_sign() could pass a NULL pointer to dst\_context\_destroy() when cleaning up after a error. [RT #15835]
- 2003. [bug] libbind: The DNS name/address lookup functions could occasionally follow a random pointer due to structures not being completely zeroed. [RT #15806]
- 2002. [bug] libbind: tighten the constraints on when struct addrinfo.\_ai\_pad exists. [RT #15783]
- 2001. [func] Check the KSK flag when updating a secure dynamic zone. New zone option "update-check-ksk yes;". [RT #15817]
- 2000. [bug] memmove()/strtol() fix was incomplete. [RT #15812]
- 1999. [func] Implement "rrset-order fixed". [RT #13662]
- 1998. [bug] Restrict handling of fifos as sockets to just SunOS. This allows named to connect to entropy gathering daemons that use fifos instead of sockets. [RT #15840]
- 1997. [bug] Named was failing to replace negative cache entries when a positive one for the type was learnt. [RT #15818]
- 1996. [bug] nsupdate: if a zone has been specified it should appear in the output of 'show'. [RT #15797]
- 1995. [bug] 'host' was reporting multiple "is an alias" messages. [RT #15702]
- 1994. [port] OpenSSL 0.9.8 support. [RT #15694]
- 1993. [bug] Log messages, via syslog, were missing the space after the timestamp if "print-time yes" was specified. [RT #15844]
- 1992. [bug] Not all incoming zone transfer messages included the view. [RT #15825]
- 1991. [cleanup] The configuration data, once read, should be treated as read only. Expand the use of const to enforce this at compile time. [RT #15813]
- 1990. [bug] libbind: isc's override of broken gettimeofday() implementations was not always effective. [RT #15709]
- 1989. [bug] win32: don't check the service password when re-installing. [RT #15882]

(continues on next page)

(continued from previous page)

- 1988. [bug] Remove a bus error from the SHA256/SHA512 support. [RT #15878]
- 1987. [func] DS/DLV SHA256 digest algorithm support. [RT #15608]
- 1986. [func] Report when a zone is removed. [RT #15849]
- 1985. [protocol] DLV has now been assigned a official type code of 32769. [RT #15807]
 

Note: care should be taken to ensure you upgrade both named and dnssec-signzone at the same time for zones with DLV records where named is the master server for the zone. Also any zones that contain DLV records should be removed when upgrading a slave zone. You do not however have to upgrade all servers for a zone with DLV records simultaneously.
- 1984. [func] dig, nslookup and host now advertise a 4096 byte EDNS UDP buffer size by default. [RT #15855]
- 1983. [func] Two new update policies. "selfsub" and "selfwild". [RT #12895]
- 1982. [bug] DNSKEY was being accepted on the parent side of a delegation. KEY is still accepted there for RFC 3007 validated updates. [RT #15620]
- 1981. [bug] win32: condition.c:wait() could fail to reattain the mutex lock.
- 1980. [func] dnssec-signzone: output the SOA record as the first record in the signed zone. [RT #15758]
- 1979. [port] linux: allow named to drop core after changing user ids. [RT #15753]
- 1978. [port] Handle systems which have a broken recvmsg(). [RT #15742]
- 1977. [bug] Silence noisy log message. [RT #15704]
- 1976. [bug] Handle systems with no IPv4 addresses. [RT #15695]
- 1975. [bug] libbind: isc\_gethexstring() could misparse multi-line hex strings with comments. [RT #15814]
- 1974. [doc] List each of the zone types and associated zone options separately in the ARM.
- 1973. [func] TSIG HMACSHA1, HMACSHA224, HMACSHA256, HMACSHA384 and

(continues on next page)

(continued from previous page)

		HMACSHA512 support. [RT #13606]
1972.	[contrib]	DBus dynamic forwarders integration from Jason Vas Dias <jvdias@redhat.com>.
1971.	[port]	linux: make detection of missing IF_NAMESIZE more robust. [RT #15443]
1970.	[bug]	nsupdate: adjust UDP timeout when falling back to unsigned SOA query. [RT #15775]
1969.	[bug]	win32: the socket code was freeing the socket structure too early. [RT #15776]
1968.	[bug]	Missing lock in resolver.c:validated(). [RT #15739]
1967.	[func]	dig/nslookup/host: warn about missing "QR". [RT #15779]
1966.	[bug]	Don't set CD when we have fallen back to plain DNS. [RT #15727]
1965.	[func]	Suppress spurious "recursion requested but not available" warning with 'dig +qr'. [RT #15780].
1964.	[func]	Separate out MX and SRV to CNAME checks. [RT #15723]
1963.	[port]	Tru64 4.0E doesn't support send() and recv(). [RT #15586]
1962.	[bug]	Named failed to clear old update-policy when it was removed. [RT #15491]
1961.	[bug]	Check the port and address of responses forwarded to dispatch. [RT #15474]
1960.	[bug]	Update code should set NSEC ttls from SOA MINIMUM. [RT #15465]
1959.	[func]	Control the zeroing of the negative response TTL to a soa query. Defaults "zero-no-soa-ttl yes;" and "zero-no-soa-ttl-cache no;". [RT #15460]
1958.	[bug]	Named failed to update the zone's secure state until the zone was reloaded. [RT #15412]
1957.	[bug]	Dig mishandled responses to class ANY queries. [RT #15402]
1956.	[bug]	Improve cross compile support, 'gen' is now built by native compiler. See README for additional cross compile support information. [RT #15148]

(continues on next page)

(continued from previous page)

- 1955. [bug] Pre-allocate the cache cleaning iterator. [RT #14998]
- 1954. [func] Named now falls back to advertising EDNS with a 512 byte receive buffer if the initial EDNS queries fail. [RT #14852]
- 1953. [func] The maximum EDNS UDP response named will send can now be set in named.conf (max-udp-size). This is independent of the advertised receive buffer (edns-udp-size). [RT #14852]
- 1952. [port] hpux: tell the linker to build a runtime link path "-Wl,+b:". [RT #14816].
- 1951. [security] Drop queries from particular well known ports. Don't return FORMERR to queries from particular well known ports. [RT #15636]
- 1950. [port] Solaris 2.5.1 and earlier cannot bind() then connect() a TCP socket. This prevents the source address being set for TCP connections. [RT #15628]
- 1949. [func] Addition memory leakage checks. [RT #15544]
- 1948. [bug] If was possible to trigger a REQUIRE failure in xfrin.c:maybe\_free() if named ran out of memory. [RT #15568]
- 1947. [func] It is now possible to configure named to accept expired RRSIGs. Default "dnssec-accept-expired no;". Setting "dnssec-accept-expired yes;" leaves named vulnerable to replay attacks. [RT #14685]
- 1946. [bug] resume\_dslookup() could trigger a REQUIRE failure when using forwarders. [RT #15549]
- 1945. [cleanup] dnssec-keygen: RSA (RSAMD5) is no longer recommended. To generate a RSAMD5 key you must explicitly request RSAMD5. [RT #13780]
- 1944. [cleanup] isc\_hash\_create() does not need a read/write lock. [RT #15522]
- 1943. [bug] Set the loadtime after rolling forward the journal. [RT #15647]
- 1942. [bug] If the name of a DNSKEY match that of one in trusted-keys do not attempt to validate the DNSKEY using the parents DS RRset. [RT #15649]
- 1941. [bug] ncache\_adderresult() should set eresult even if no rdataset is passed to it. [RT #15642]

(continues on next page)

(continued from previous page)

- 1940. [bug] Fixed a number of error conditions reported by Coverity.
- 1939. [bug] The resolver could dereference a null pointer after validation if all the queries have timed out. [RT #15528]
- 1938. [bug] The validator was not correctly handling unsecure negative responses at or below a SEP. [RT #15528]
- 1937. [bug] sdlz doesn't handle RRSIG records. [RT #15564]
- 1936. [bug] The validator could leak memory. [RT #15544]
- 1935. [bug] 'acache' was DO sensitive. [RT #15430]
- 1934. [func] Validate pending NS RRsets, in the authority section, prior to returning them if it can be done without requiring DNSKEYs to be fetched. [RT #15430]
- 1933. [bug] dump\_rdataset\_raw() had a incorrect INSIST. [RT #15534]
- 1932. [bug] hpux: LDFLAGS was getting corrupted. [RT #15530]
- 1931. [bug] Per-client mctx could require a huge amount of memory, particularly for a busy caching server. [RT #15519]
- 1930. [port] HPUX: ia64 support. [RT #15473]
- 1929. [port] FreeBSD: extend use of PTHREAD\_SCOPE\_SYSTEM.
- 1928. [bug] Race in rbtodb.c:currentversion(). [RT #15517]
- 1927. [bug] Access to soanode or nsnode in rbtodb violated the lock order rule and could cause a dead lock. [RT #15518]
- 1926. [bug] The Windows installer did not check for empty passwords. BINDinstall was being installed in the wrong place. [RT #15483]
- 1925. [port] All outer level AC\_TRY\_RUNs need cross compiling defaults. [RT #15469]
- 1924. [port] libbind: hpux ia64 support. [RT #15473]
- 1923. [bug] ns\_client\_detach() called too early. [RT #15499]
- 1922. [bug] check-tool.c:setup\_logging() missing call to dns\_log\_setcontext().

(continues on next page)

(continued from previous page)

- 1921. [bug] Client memory contexts were not using internal malloc. [RT #15434]
- 1920. [bug] The cache rbtodb lock array was too small to have the desired performance characteristics. [RT #15454]
- 1919. [contrib] queryperf: a set of new features: collecting/printing response delays, printing intermediate results, and adjusting query rate for the "target" qps.
- 1918. [bug] Memory leak when checking acls. [RT #15391]
- 1917. [doc] funcsynopsisinfo wasn't being treated as verbatim when generating man pages. [RT #15385]
- 1916. [func] Integrate contributed IDN code from JPNIC. [RT #15383]
- 1915. [bug] dig +ndots was broken. [RT #15215]
- 1914. [protocol] DS is required to accept mnemonic algorithms (RFC 4034). Still emit numeric algorithms for compatibility with RFC 3658. [RT #15354]
- 1913. [func] Integrate contributed DLZ code into named. [RT #11382]
- 1912. [port] aix: atomic locking for powerpc. [RT #15020]
- 1911. [bug] Update windows socket code. [RT #14965]
- 1910. [bug] dig's +sigchase code overhauled. [RT #14933]
- 1909. [bug] The DLV code has been re-worked to make no longer query order sensitive. [RT #14933]
- 1908. [func] dig now warns if 'RA' is not set in the answer when 'RD' was set in the query. host/nslookup skip servers that fail to set 'RA' when 'RD' is set unless a server is explicitly set. [RT #15005]
- 1907. [func] host/nslookup now continue (default)/fail on SERVFAIL. [RT #15006]
- 1906. [func] dig now has a '-q queryname' and '+showsearch' options. [RT #15034]
- 1905. [bug] Strings returned from cfg\_obj\_asstring() should be treated as read-only. The prototype for cfg\_obj\_asstring() has been updated to reflect this. [RT #15256]
- 1904. [func] Automatic empty zone creation for D.F.IP6.ARPA and

(continues on next page)

(continued from previous page)

		friends. Note: RFC 1918 zones are not yet covered by this but are likely to be in a future release.
		New options: empty-server, empty-contact, empty-zones-enable and disable-empty-zone.
1903.	[func]	ISC string copy API.
1902.	[func]	Attempt to make the amount of work performed in a iteration self tuning. The covers nodes clean from the cache per iteration, nodes written to disk when rewriting a master file and nodes destroyed per iteration when destroying a zone or a cache. [RT #14996]
1901.	[cleanup]	Don't add DNSKEY records to the additional section.
1900.	[bug]	ixfr-from-differences failed to ensure that the serial number increased. [RT #15036]
1899.	[func]	named-checkconf now validates update-policy entries. [RT #14963]
1898.	[bug]	Extend ISC_SOCKADDR_FORMATSIZE and ISC_NETADDR_FORMATSIZE to allow for scope details.
1897.	[func]	x86 and x86_64 now have separate atomic locking implementations.
1896.	[bug]	Recursive clients soft quota support wasn't working as expected. [RT #15103]
1895.	[bug]	A escaped character is, potentially, converted to the output character set too early. [RT #14666]
1894.	[doc]	Review ARM for BIND 9.4.
1893.	[port]	Use uintptr_t if available. [RT #14606]
1892.	[func]	Support for SPF rdata type. [RT #15033]
1891.	[port]	freebsd: pthread_mutex_init can fail if it runs out of memory. [RT #14995]
1890.	[func]	Raise the UDP receive buffer size to 32k if it is less than 32k. [RT #14953]
1889.	[port]	sunos: non blocking i/o support. [RT #14951]
1888.	[func]	Support for IPSECKEY rdata type. [RT #14967]
1887.	[bug]	The cache could delete expired records too fast for

(continues on next page)

(continued from previous page)

		clients with a virtual time in the past. [RT #14991]
1886.	[bug]	fctx_create() could return success even though it failed. [RT #14993]
1885.	[func]	dig: report the number of extra bytes still left in the packet after processing all the records.
1884.	[cleanup]	dighost.c: move external declarations into <dig/dig.h>.
1883.	[bug]	dnssec-signzone, dnssec-keygen: handle negative debug levels. [RT #14962]
1882.	[func]	Limit the number of recursive clients that can be waiting for a single query (<qname,qtype,qclass>) to resolve. New options clients-per-query and max-clients-per-query.
1881.	[func]	Add a system test for named-checkconf. [RT #14931]
1880.	[func]	The lame cache is now done on a <qname,qclass,qtype> basis as some servers only appear to be lame for certain query types. [RT #14916]
1879.	[func]	"USE INTERNAL MALLOC" is now runtime selectable. [RT #14892]
1878.	[func]	Detect duplicates of UDP queries we are recursing on and drop them. New stats category "duplicate". [RT #2471]
1877.	[bug]	Fix unreasonably low quantum on call to dns_rbt_destroy2(). Remove unnecessary unhash_node() call. [RT #14919]
1876.	[func]	Additional memory debugging support to track size and mctx arguments. [RT #14814]
1875.	[bug]	process_dhtkey() was using the wrong memory context to free some memory. [RT #14890]
1874.	[port]	sunos: portability fixes. [RT #14814]
1873.	[port]	win32: isc__errno2result() now reports its caller. [RT #13753]
1872.	[port]	win32: Handle ERROR_NETNAME_DELETED. [RT #13753]
1871.	[placeholder]	
1870.	[func]	Added framework for handling multiple EDNS versions. [RT #14873]

(continues on next page)

(continued from previous page)

- 1869. [func] dig can now specify the EDNS version when making a query. [RT #14873]
- 1868. [func] edns-udp-size can now be overridden on a per server basis. [RT #14851]
- 1867. [bug] It was possible to trigger a INSIST in dlvs\_validatezonekey(). [RT #14846]
- 1866. [bug] resolv.conf parse errors were being ignored by dig/host/nslookup. [RT #14841]
- 1865. [bug] Silently ignore nameservers in /etc/resolv.conf with bad addresses. [RT #14841]
- 1864. [bug] Don't try the alternative transfer source if you got a answer / transfer with the main source address. [RT #14802]
- 1863. [bug] rrset-order "fixed" error messages not complete.
- 1862. [func] Add additional zone data constancy checks. named-checkzone has extended checking of NS, MX and SRV record and the hosts they reference. named has extended post zone load checks. New zone options: check-mx and integrity-check. [RT #4940]
- 1861. [bug] dig could trigger a INSIST on certain malformed responses. [RT #14801]
- 1860. [port] solaris 2.8: hack\_shutup\_pthreadmutexinit was incorrectly set. [RT #14775]
- 1859. [func] Add support for CH A record. [RT #14695]
- 1858. [bug] The flush-zones-on-shutdown option wasn't being parsed. [RT #14686]
- 1857. [bug] named could trigger a INSIST() if reconfigured / reloaded too fast. [RT #14673]
- 1856. [doc] Switch Docbook toolchain from DSSSL to XSL. [RT #11398]
- 1855. [bug] ixfr-from-differences was failing to detect changes of ttl due to dns\_diff\_subtract() was ignoring the ttl of records. [RT #14616]
- 1854. [bug] lwres also needs to know the print format for (long long). [RT #13754]

(continues on next page)

(continued from previous page)

- 1853. [bug] Rework how DLV interacts with proveunsecure().  
[RT #13605]
- 1852. [cleanup] Remove last vestiges of dnssec-signkey and  
dnssec-makekeyset (removed from Makefile years ago).
- 1851. [doc] Doxygen comment markup. [RT #11398]
- 1850. [bug] Memory leak in lwres\_getipnodebyaddr(). [RT #14591]
- 1849. [doc] All forms of the man pages (docbook, man, html) should  
have consistent copyright dates.
- 1848. [bug] Improve SMF integration. [RT #13238]
- 1847. [bug] isc\_ondestroy\_init() is called too late in  
dns\_rbtodb\_create()/dns\_rbtodb64\_create().  
[RT #13661]
- 1846. [contrib] query-loc-0.3.0 from Stephane Bortzmeyer  
<bortzmeyer@nic.fr>.
- 1845. [bug] Improve error reporting to distinguish between  
accept()/fcntl() and socket()/fcntl() errors.  
[RT #13745]
- 1844. [bug] inet\_pton() accepted more than 4 hexadecimal digits  
for each 16 bit piece of the IPv6 address. The text  
representation of a IPv6 address has been tightened  
to disallow this (draft-ietf-ipv6-addr-arch-v4-02.txt).  
[RT #5662]
- 1843. [cleanup] CINCLUDES takes precedence over CFLAGS. This helps  
when CFLAGS contains "-I /usr/local/include"  
resulting in old header files being used.
- 1842. [port] cmsg\_len() could produce incorrect results on  
some platform. [RT #13744]
- 1841. [bug] "dig +nssearch" now makes a recursive query to  
find the list of nameservers to query. [RT #13694]
- 1840. [func] dnssec-signzone can now randomize signature end times  
(dnssec-signzone -j jitter). [RT #13609]
- 1839. [bug] <isc/hash.h> was not being installed.
- 1838. [cleanup] Don't allow Linux capabilities to be inherited.  
[RT #13707]
- 1837. [bug] Compile time option ISC\_FACILITY was not effective

(continues on next page)

(continued from previous page)

- for 'named -u <user>'. [RT #13714]
- 1836. [cleanup] Silence compiler warnings in hash\_test.c.
- 1835. [bug] Update dnssec-signzone's usage message. [RT #13657]
- 1834. [bug] Bad memset in rdata\_test.c. [RT #13658]
- 1833. [bug] Race condition in isc\_mutex\_lock\_profile(). [RT #13660]
- 1832. [bug] named fails to return BADKEY on unknown TSIG algorithm. [RT #13620]
- 1831. [doc] Update named-checkzone documentation. [RT #13604]
- 1830. [bug] adb lame cache has sense of test reversed. [RT #13600]
- 1829. [bug] win32: "pid-file none;" broken. [RT #13563]
- 1828. [bug] isc\_rwlock\_init() failed to properly cleanup if it encountered a error. [RT #13549]
- 1827. [bug] host: update usage message for '-a'. [RT #37116]
- 1826. [bug] Missing DESTROYLOCK() in isc\_mem\_createx() on out of memory error. [RT #13537]
- 1825. [bug] Missing UNLOCK() on out of memory error from in rbtodb.c:subtractrdataset(). [RT #13519]
- 1824. [bug] Memory leak on dns\_zone\_setdbtype() failure. [RT #13510]
- 1823. [bug] Wrong macro used to check for point to point interface. [RT #13418]
- 1822. [bug] check-names test for RT was reversed. [RT #13382]
- 1821. [placeholder]
- 1820. [bug] Gracefully handle acl loops. [RT #13659]
- 1819. [bug] The validator needed to check both the algorithm and digest types of the DS to determine if it could be used to introduce a secure zone. [RT #13593]
- 1818. [bug] 'named-checkconf -z' triggered an INSIST. [RT #13599]
- 1817. [func] Add support for additional zone file formats for improving loading performance. The masterfile-format option in named.conf can be used to specify a non-default format. A separate command

(continues on next page)

(continued from previous page)

		named-compilezone was provided to generate zone files in the new format. Additionally, the -I and -O options for dnssec-signzone specify the input and output formats.
1816.	[port]	UnixWare: failed to compile lib/isc/unix/net.c. [RT #13597]
1815.	[bug]	nsupdate triggered a REQUIRE if the server was set without also setting the zone and it encountered a CNAME and was using TSIG. [RT #13086]
1814.	[func]	UNIX domain controls are now supported.
1813.	[func]	Restructured the data locking framework using architecture dependent atomic operations (when available), improving response performance on multi-processor machines significantly. x86, x86_64, alpha, powerpc, and mips are currently supported.
1812.	[port]	win32: IN6_IS_ADDR_UNSPECIFIED macro is incorrect. [RT #13453]
1811.	[func]	Preserve the case of domain names in rdata during zone transfers. [RT #13547]
1810.	[bug]	configure, lib/bind/configure make different default decisions about whether to do a threaded build. [RT #13212]
1809.	[bug]	"make distclean" failed for libbind if the platform is not supported.
1808.	[bug]	zone.c:notify_zone() contained a race condition, zone->db could change underneath it. [RT #13511]
1807.	[bug]	When forwarding (forward only) set the active domain from the forward zone name. [RT #13526]
1806.	[bug]	The resolver returned the wrong result when a CNAME / DNAME was encountered when fetching glue from a secure namespace. [RT #13501]
1805.	[bug]	Pending status was not being cleared when DLV was active. [RT #13501]
1804.	[bug]	Ensure that if we are queried for glue that it fits in the additional section or TC is set to tell the client to retry using TCP. [RT #10114]
1803.	[bug]	dnssec-signzone sometimes failed to remove old

(continues on next page)

(continued from previous page)

		RRSIGs. [RT #13483]
1802.	[bug]	Handle connection resets better. [RT #11280]
1801.	[func]	Report differences between hints and real NS rreset and associated address records.
1800.	[bug]	Changes #1719 allowed a INSIST to be triggered. [RT #13428]
1799.	[bug]	'rndc flushname' failed to flush negative cache entries. [RT #13438]
1798.	[func]	The server syntax has been extended to support a range of servers. [RT #11132]
1797.	[func]	named-checkconf now check acls to verify that they only refer to existing acls. [RT #13101]
1796.	[func]	"rndc freeze/thaw" now freezes/thaws all zones.
1795.	[bug]	"rndc dumpdb" was not fully documented. Minor formatting issues with "rndc dumpdb -all". [RT #13396]
1794.	[func]	Named and named-checkzone can now both check for non-terminal wildcard records.
1793.	[func]	Extend adjusting TTL warning messages. [RT #13378]
1792.	[func]	New zone option "notify-delay". Specify a minimum delay between sets of NOTIFY messages.
1791.	[bug]	'host -t a' still printed out AAAA and MX records. [RT #13230]
1790.	[cleanup]	Move lib/dns/sec/dst up into lib/dns. This should allow parallel make to succeed.
1789.	[bug]	Prerequisite test for tkey and dnssec could fail with "configure --with-libtool".
1788.	[bug]	libbind9.la/libbind9.so needs to link against libisccfg.la/libisccfg.so.
1787.	[port]	HPUX: both "cc" and "gcc" need -Wl,+vnocompatwarnings.
1786.	[port]	AIX: libt_api needs to be taught to look for T_testlist in the main executable (--with-libtool). [RT #13239]
1785.	[bug]	libbind9.la/libbind9.so needs to link against libisc.la/libisc.so.

(continues on next page)

(continued from previous page)

- 1784. [cleanup] "libtool --allow-undefined" is the default. Leave hooks in configure to allow it to be set if needed in the future.
- 1783. [cleanup] We only need one copy of libtool.m4, ltmain.sh in the source tree.
- 1782. [port] OSX: --with-libtool + --enable-libbind broke on \_\_evOptMonoTime. [RT #13219]
- 1781. [port] FreeBSD 5.3: set PTHREAD\_SCOPE\_SYSTEM. [RT #12810]
- 1780. [bug] Update libtool to 1.5.10.
- 1779. [port] OSF 5.1: libtool didn't handle -pthread correctly.
- 1778. [port] HUX 11.11: fix broken IN6ADDR\_ANY\_INIT and IN6ADDR\_LOOPBACK\_INIT macros.
- 1777. [port] OSF 5.1: fix broken IN6ADDR\_ANY\_INIT and IN6ADDR\_LOOPBACK\_INIT macros.
- 1776. [port] Solaris 2.9: fix broken IN6ADDR\_ANY\_INIT and IN6ADDR\_LOOPBACK\_INIT macros.
- 1775. [bug] Only compile getnetent\_r.c when threaded. [RT #13205]
- 1774. [port] Aix: Silence compiler warnings / build failures. [RT #13154]
- 1773. [bug] Fast retry on host / net unreachable. [RT #13153]
- 1772. [placeholder]
- 1771. [placeholder]
- 1770. [bug] named-checkconf failed to report missing a missing file clause for rbt{64} master/hint zones. [RT #13009]
- 1769. [port] win32: change compiler flags /MTd ==> /MDd, /MT ==> /MD.
- 1768. [bug] nsecnoexistnodata() could be called with a non-NSEC rdataset. [RT #12907]
- 1767. [port] Builds on IPv6 platforms without IPv6 Advanced API support for (struct in6\_pktinfo) failed. [RT #13077]
- 1766. [bug] Update the master file timestamp on successful refresh as well as the journal's timestamp. [RT #13062]

(continues on next page)

(continued from previous page)

1765.	[bug]	configure --with-openssl=auto failed. [RT #12937]
1764.	[bug]	dns_zone_replacedb failed to emit a error message if there was no SOA record in the replacement db. [RT #13016]
1763.	[func]	Perform sanity checks on NS records which refer to 'in zone' names. [RT #13002]
1762.	[bug]	isc_interfaceiter_create() could return ISC_R_SUCCESS even when it failed. [RT #12995]
1761.	[bug]	'rndc dumpdb' didn't report unassociated entries. [RT #12971]
1760.	[bug]	Host / net unreachable was not penalising rtt estimates. [RT #12970]
1759.	[bug]	Named failed to startup if the OS supported IPv6 but had no IPv6 interfaces configured. [RT #12942]
1758.	[func]	Don't send notify messages to self. [RT #12933]
1757.	[func]	host now can turn on memory debugging flags with '-m'.
1756.	[func]	named-checkconf now checks the logging configuration. [RT #12352]
1755.	[func]	allow-update is now settable at the options / view level. [RT #6636]
1754.	[bug]	We weren't always attempting to query the parent server for the DS records at the zone cut. [RT #12774]
1753.	[bug]	Don't serve a slave zone which has no NS records. [RT #12894]
1752.	[port]	Move isc_app_start() to after ns_os_daemonise() as some fork() implementations unblock the signals that are blocked by isc_app_start(). [RT #12810]
1751.	[bug]	--enable-getifaddrs failed under linux. [RT #12867]
1750.	[port]	lib/bind/make/rules.in:subdirs was not bash friendly. [RT #12864]

1749.	[bug]	'check-names response ignore;' failed to ignore. [RT #12866]
1748.	[func]	dig now returns the byte count for axfr/ixfr.

(continues on next page)

(continued from previous page)

1747.	[bug]	BIND 8 compatibility: named/named-checkconf failed to parse "host-statistics-max" in named.conf.
1746.	[func]	Make public the function to read a key file, dst_key_read_public(). [RT #12450]
1745.	[bug]	Dig/host/nslookup accept replies from link locals regardless of scope if no scope was specified when query was sent. [RT #12745]
1744.	[bug]	If tuple2msgname() failed to convert a tuple to a name a REQUIRE could be triggered. [RT #12796]
1743.	[bug]	If isc_taskmgr_create() was not able to create the requested number of worker threads then destruction of the manager would trigger an INSIST() failure. [RT #12790]
1742.	[bug]	Deleting all records at a node then adding a previously existing record, in a single UPDATE transaction, failed to leave / regenerate the associated RRSIG records. [RT #12788]
1741.	[bug]	Deleting all records at a node in a secure zone using a update-policy grant failed. [RT #12787]
1740.	[bug]	Replace rbt's hash algorithm as it performed badly with certain zones. [RT #12729]
		NOTE: a hash context now needs to be established via isc_hash_create() if the application was not already doing this.
1739.	[bug]	dns_rbt_deletetree() could incorrectly return ISC_R_QUOTA. [RT #12695]
1738.	[bug]	Enable overrun checking by default. [RT #12695]
1737.	[bug]	named failed if more than 16 masters were specified. [RT #12627]
1736.	[bug]	dst_key_fromnamedfile() could fail to read a public key. [RT #12687]
1735.	[bug]	'dig +sigtrace' could die with a REQUIRE failure. [RE #12688]
1734.	[cleanup]	'rndc-confgen -a -t' remove extra '/' in path. [RT #12588]
1733.	[bug]	Return non-zero exit status on initial load failure. [RT #12658]

(continues on next page)

(continued from previous page)

- 1732. [bug] 'rrset-order name "\*" wasn't being applied to ".".  
[RT #12467]
- 1731. [port] darwin: relax version test in ifconfig.sh.  
[RT #12581]
- 1730. [port] Determine the length type used by the socket API.  
[RT #12581]
- 1729. [func] Improve check-names error messages.
- 1728. [doc] Update check-names documentation.
- 1727. [bug] named-checkzone: check-names support didn't match  
documentation.
- 1726. [port] aix5: add support for aix5.
- 1725. [port] linux: update error message on interaction of threads,  
capabilities and setuid support (named -u). [RT #12541]
- 1724. [bug] Look for DNSKEY records with "dig +sigtrace".  
[RT #12557]
- 1723. [cleanup] Silence compiler warnings from t\_tasks.c. [RT #12493]
- 1722. [bug] Don't commit the journal on malformed ixfr streams.  
[RT #12519]
- 1721. [bug] Error message from the journal processing were not  
always identifying the relevant journal. [RT #12519]
- 1720. [bug] 'dig +chase' did not terminate on a RFC 2308 Type 1  
negative response. [RT #12506]
- 1719. [bug] named was not correctly caching a RFC 2308 Type 1  
negative response. [RT #12506]
- 1718. [bug] nsupdate was not handling RFC 2308 Type 3 negative  
responses when looking for the zone / master server.  
[RT #12506]
- 1717. [port] solaris: ifconfig.sh did not support Solaris 10.  
"ifconfig.sh down" didn't work for Solaris 9.
- 1716. [doc] named.conf(5) was being installed in the wrong  
location. [RT #12441]
- 1715. [func] 'dig +trace' now randomly selects the next servers  
to try. Report if there is a bad delegation.

(continues on next page)

(continued from previous page)

- 1714. [bug] dig/host/nslookup were only trying the first address when a nameserver was specified by name. [RT #12286]
- 1713. [port] linux: extend capset failure message to say: please ensure that the capset kernel module is loaded. see insmod(8)
- 1712. [bug] Missing FULLCHECK for "trusted-key" in dig.
- 1711. [func] 'rndc unfreeze' has been deprecated by 'rndc thaw'.
- 1710. [func] 'rndc notify zone [class [view]]' resend the NOTIFY messages for the specified zone. [RT #9479]
- 1709. [port] solaris: add SMF support from Sun.
- 1708. [cleanup] Replaced dns\_fullname\_hash() with dns\_name\_fullhash() for conformance to the name space convention. Binary backward compatibility to the old function name is provided. [RT #12376]
- 1707. [contrib] sdb/ldap updated to version 1.0-beta.
- 1706. [bug] 'rndc stop' failed to cause zones to be flushed sometimes. [RT #12328]
- 1705. [func] Allow the journal's name to be changed via named.conf.
- 1704. [port] lwres needed a sprintf() implementation for platforms without sprintf(). Add missing "#include <isc/print.h>". [RT #12321]
- 1703. [bug] named would loop sending NOTIFY messages when it failed to receive a response. [RT #12322]
- 1702. [bug] also-notify should not be applied to built in zones. [RT #12323]
- 1701. [doc] A minimal named.conf man page.
- 1700. [func] nslookup is no longer to be treated as deprecated. Remove "deprecated" warning message. Add man page.
- 1699. [bug] dnssec-signzone can generate "not exact" errors when resigning. [RT #12281]
- 1698. [doc] Use reserved IPv6 documentation prefix.
- 1697. [bug] xxx-source{,-v6} was not effective when it specified one of listening addresses and a different port than the listening port. [RT #12257]

(continues on next page)

(continued from previous page)

1696. [bug] dnssec-signzone failed to clean out nodes that consisted of only NSEC and RRSIG records. [RT #12154]
1695. [bug] DS records when forwarding require special handling. [RT #12133]
1694. [bug] Report if the builtin views of "\_default" / "\_bind" are defined in named.conf. [RT #12023]
1693. [bug] max-journal-size was not effective for master zones with ixfr-from-differences set. [RT #12024]
1692. [bug] Don't set -I, -L and -R flags when libcrypto is in /usr/lib. [RT #11971]
1691. [bug] sdb's attachversion was not complete. [RT #11990]
1690. [bug] Delay detaching view from the client until UPDATE processing completes when shutting down. [RT #11714]
1689. [bug] DNS\_NAME\_TOREGION() and DNS\_NAME\_SPLIT() macros contained gratuitous semicolons. [RT #11707]
1688. [bug] LDFlags was not supported.
1687. [bug] Race condition in dispatch. [RT #10272]
1686. [bug] Named sent a extraneous NOTIFY when it received a redundant UPDATE request. [RT #11943]
1685. [bug] Change #1679 loop tests weren't quite right.
1684. [func] ixfr-from-differences now takes master and slave in addition to yes and no at the options and view levels.
1683. [bug] dig +sigchase could leak memory. [RT #11445]
1682. [port] Update configure test for (long long) printf format. [RT #5066]
1681. [bug] Only set SO\_REUSEADDR when a port is specified in isc\_socket\_bind(). [RT #11742]
1680. [func] rndc: the source address can now be specified.
1679. [bug] When there was a single nameserver with multiple addresses for a zone not all addresses were tried. [RT #11706]
1678. [bug] RRSIG should use TYPEXXXXX for unknown types.

(continues on next page)

(continued from previous page)

- 1677. [bug] dig: +aaonly didn't work, +aaflag undocumented.
- 1676. [func] New option "allow-query-cache". This lets allow-query be used to specify the default zone access level rather than having to have every zone override the global value. allow-query-cache can be set at both the options and view levels. If allow-query-cache is not set allow-query applies.
- 1675. [bug] named would sometimes add extra NSEC records to the authority section.
- 1674. [port] linux: increase buffer size used to scan /proc/net/if\_inet6.
- 1673. [port] linux: issue a error messages if IPv6 interface scans fails.
- 1672. [cleanup] Tests which only function in a threaded build now return R:THREADONLY (rather than R:UNTESTED) in a non-threaded build.
- 1671. [contrib] queryperf: add NAPTR to the list of known types.
- 1670. [func] Log UPDATE requests to slave zones without an acl as "disabled" at debug level 3. [RT #11657]
- 1669. [placeholder]
- 1668. [bug] DIG\_SIGCHASE was making bin/dig/host dump core.
- 1667. [port] linux: not all versions have IF\_NAMESIZE.
- 1666. [bug] The optional port on hostnames in dual-stack-servers was being ignored.
- 1665. [func] rndc now allows addresses to be set in the server clauses.
- 1664. [bug] nsupdate needed KEY for SIG(0), not DNSKEY.
- 1663. [func] Look for OpenSSL by default.
- 1662. [bug] Change #1658 failed to change one use of 'type' to 'keytype'.
- 1661. [bug] Restore dns\_name\_concatenate() call in adb.c:set\_target(). [RT #11582]
- 1660. [bug] win32: connection\_reset\_fix() was being called unconditionally. [RT #11595]

(continues on next page)

(continued from previous page)

- 1659. [cleanup] Cleanup some messages that were referring to KEY vs DNSKEY, NXT vs NSEC and SIG vs RRSIG.
- 1658. [func] Update dnssec-keygen to default to KEY for HMAC-MD5 and DH. Tighten which options apply to KEY and DNSKEY records.
- 1657. [doc] ARM: document query log output.
- 1656. [doc] Update DNSSEC description in ARM to cover DS, NSEC DNSKEY and RRSIG. [RT #11542]
- 1655. [bug] Logging multiple versions w/o a size was broken. [RT #11446]
- 1654. [bug] isc\_result\_totext() contained array bounds read error.
- 1653. [func] Add key type checking to dst\_key\_fromfilename(), DST\_TYPE\_KEY should be used to read TSIG, TKEY and SIG(0) keys.
- 1652. [bug] TKEY still uses KEY.
- 1651. [bug] dig: process multiple dash options.
- 1650. [bug] dig, nslookup: flush standard out after each command.
- 1649. [bug] Silence "unexpected non-minimal diff" message. [RT #11206]
- 1648. [func] Update dnssec-lookaside named.conf syntax to support multiple dnssec-lookaside namespaces (not yet implemented).
- 1647. [bug] It was possible trigger a INSIST when chasing a DS record that required walking back over a empty node. [RT #11445]
- 1646. [bug] win32: logging file versions didn't work with non-UNC filenames. [RT #11486]
- 1645. [bug] named could trigger a REQUIRE failure if multiple masters with keys are specified.
- 1644. [bug] Update the journal modification time after a successful refresh query. [RT #11436]
- 1643. [bug] dns\_db\_closeversion() could leak memory / node references. [RT #11163]

(continues on next page)

(continued from previous page)

- 1642. [port] Support OpenSSL implementations which don't have DSA support. [RT #11360]
- 1641. [bug] Update the check-names description in ARM. [RT #11389]
- 1640. [bug] win32: isc\_socket\_cancel(ISC\_SOCKCANCEL\_ACCEPT) was incorrectly closing the socket. [RT #11291]
- 1639. [func] Initial dlvs system test.
- 1638. [bug] "ixfr-from-differences" could generate a REQUIRE failure if the journal open failed. [RT #11347]
- 1637. [bug] Node reference leak on error in addnoqname().
- 1636. [bug] The dump done callback could get ISC\_R\_SUCCESS even if a error had occurred. The database version no longer matched the version of the database that was dumped.
- 1635. [bug] Memory leak on error in query\_addds().
- 1634. [bug] named didn't supply a useful error message when it detected duplicate views. [RT #11208]
- 1633. [bug] named should return NOTIMP to update requests to a slaves without a allow-update-forwarding acl specified. [RT #11331]
- 1632. [bug] nsupdate failed to send prerequisite only UPDATE messages. [RT #11288]
- 1631. [bug] dns\_journal\_compact() could sometimes corrupt the journal. [RT #11124]
- 1630. [contrib] queryperf: add support for IPv6 transport.
- 1629. [func] dig now supports IPv6 scoped addresses with the extended format in the local-server part. [RT #8753]
- 1628. [bug] Typo in Compaq Trucluster support. [RT #11264]
- 1627. [bug] win32: sockets were not being closed when the last external reference was removed. [RT #11179]
- 1626. [bug] --enable-getifaddrs was broken. [RT #11259]
- 1625. [bug] named failed to load/transfer RFC2535 signed zones which contained CNAMEs. [RT #11237]
- 1624. [bug] zonemgr\_putio() call should be locked. [RT #11163]
- 1623. [bug] A serial number of zero was being displayed in the

(continues on next page)

(continued from previous page)

		"sending notifies" log message when also-notify was used. [RT #11177]
1622.	[func]	probe the system to see if IPV6_(RECV)PKTINFO is available, and suppress wildcard binding if not.
1621.	[bug]	match-destinations did not work for IPv6 TCP queries. [RT #11156]
1620.	[func]	When loading a zone report if it is signed. [RT #11149]
1619.	[bug]	Missing ISC_LIST_UNLINK in end_reserved_dispatches(). [RT #11118]
1618.	[bug]	Fencepost errors in dns_name_ishostname() and dns_name_ismailbox() could trigger a INSIST().
1617.	[port]	win32: VC++ 6.0 support.
1616.	[compat]	Ensure that named's version is visible in the core dump. [RT #11127]
1615.	[port]	Define ISC_SOCKADDR_LEN_T based on _BSD_SOCKLEN_T_ if it is defined.
1614.	[port]	win32: silence resource limit messages. [RT #11101]
1613.	[bug]	Builds would fail on machines w/o a if_nametoindex(). Missing #ifdef ISC_PLATFORM_HAVEIFNAMETOINDEX/#endif. [RT #11119]
1612.	[bug]	check-names at the option/view level could trigger an INSIST. [RT #11116]
1611.	[bug]	solaris: IPv6 interface scanning failed to cope with no active IPv6 interfaces.
1610.	[bug]	On dual stack machines "dig -b" failed to set the address type to be looked up with "@server". [RT #11069]
1609.	[func]	dig now has support to chase DNSSEC signature chains. Requires -DDIG_SIGCHASE=1 to be set in STD_CDEFINES.  DNSSEC validation code in dig coded by Olivier Courtay (olivier.courtay@irisa.fr) for the IDSA project ( <a href="http://idsa.irisa.fr">http://idsa.irisa.fr</a> ).
1608.	[func]	dig and host now accept -4/-6 to select IP transport to use when making queries.
1607.	[bug]	dig, host and nslookup were still using random()

(continues on next page)

(continued from previous page)

		to generate query ids. [RT #11013]
1606.	[bug]	DLV insecurity proof was failing.
1605.	[func]	New dns_db_find() option DNS_DBFIND_COVERINGNSEC.
1604.	[bug]	A xfrout_ctx_create() failure would result in xfrout_ctx_destroy() being called with a partially initialized structure.
1603.	[bug]	nsupdate: set interactive based on isatty(). [RT #10929]
1602.	[bug]	Logging to a file failed unless a size was specified. [RT #10925]
1601.	[bug]	Silence spurious warning 'both "recursion no;" and "allow-recursion" active' warning from view "_bind". [RT #10920]
1600.	[bug]	Duplicate zone pre-load checks were not case insensitive.
1599.	[bug]	Fix memory leak on error path when checking named.conf.
1598.	[func]	Specify that certain parts of the namespace must be secure (dnssec-must-be-secure).
1597.	[func]	Allow notify-source and query-source to be specified on a per server basis similar to transfer-source. [RT #6496]
1596.	[func]	Accept 'notify-source' style syntax for query-source.
1595.	[func]	New notify type 'master-only'. Enable notify for master zones only.
1594.	[bug]	'rndc dumpdb' could prevent named from answering queries while the dump was in progress. [RT #10565]
1593.	[bug]	rndc should return "unknown command" to unknown commands. [RT #10642]
1592.	[bug]	configure_view() could leak a dispatch. [RT #10675]
1591.	[bug]	libbind: updated to BIND 8.4.5.
1590.	[port]	netbsd: update thread support.
1589.	[func]	DNSSEC lookaside validation.
1588.	[bug]	win32: TCP sockets could become blocked. [RT #10115]

(continues on next page)

(continued from previous page)

- 1587. [bug] dns\_message\_settsigkey() failed to clear existing key.  
[RT #10590]
- 1586. [func] "check-names" is now implemented.
- 1585. [placeholder]
- 1584. [bug] "make test" failed with a read only source tree.  
[RT #10461]
- 1583. [bug] Records add via UPDATE failed to get the correct trust  
level. [RT #10452]
- 1582. [bug] rrset-order failed to work on RRsets with more  
than 32 elements. [RT #10381]
- 1581. [func] Disable DNSSEC support by default. To enable  
DNSSEC specify "dnssec-enable yes;" in named.conf.
- 1580. [bug] Zone destruction on final detach takes a long time.  
[RT #3746]
- 1579. [bug] Multiple task managers could not be created.
- 1578. [bug] Don't use CLASS E IPv4 addresses when resolving.  
[RT #10346]
- 1577. [bug] Use isc\_uint32\_t in ultrasparc optimizer bug  
workaround code. [RT #10331]
- 1576. [bug] Race condition in dns\_dispatch\_addresponse().  
[RT #10272]
- 1575. [func] Log TSIG name on TSIG verify failure. [RT #4404]
- 1574. [bug] Don't attempt to open the controls socket(s) when  
running tests. [RT #9091]
- 1573. [port] linux: update to libtool 1.5.2 so that  
"make install DESTDIR=/xx" works with  
"configure --with-libtool". [RT #9941]
- 1572. [bug] nsupdate: sign the soa query to find the enclosing  
zone if the server is specified. [RT #10148]
- 1571. [bug] rbt:hash\_node() could fail leaving the hash table  
in an inconsistent state. [RT #10208]
- 1570. [bug] nsupdate failed to handle classes other than IN.  
New keyword 'class' which sets the default class.  
[RT #10202]

(continues on next page)

(continued from previous page)

- 1569. [func] nsupdate new command 'answer' which displays the complete answer message to the last update.
- 1568. [bug] nsupdate now reports that the update failed in interactive mode. [RT #10236]
- 1567. [maint] B.ROOT-SERVERS.NET is now 192.228.79.201.
- 1566. [port] Support for the cmsg framework on Solaris and HP/UX. This also solved the problem that match-destinations for IPv6 addresses did not work on these systems. [RT #10221]
- 1565. [bug] CD flag should be copied to outgoing queries unless the query is under a secure entry point in which case CD should be set.
- 1564. [func] Attempt to provide a fallback entropy source to be used if named is running chrooted and named is unable to open entropy source within the chroot area. [RT #10133]
- 1563. [bug] Gracefully fail when unable to obtain neither an IPv4 nor an IPv6 dispatch. [RT #10230]
- 1562. [bug] isc\_socket\_create() and isc\_socket\_accept() could leak memory under error conditions. [RT #10230]
- 1561. [bug] It was possible to release the same name twice if named ran out of memory. [RT #10197]
- 1560. [port] FreeBSD: work around FreeBSD 5.2 mapping EAI\_NODATA and EAI\_NONAME to the same value.
- 1559. [port] named should ignore SIGFSZ.
- 1558. [func] New DNSSEC 'disable-algorithms'. Support entry into child zones for which we don't have a supported algorithm. Such child zones are treated as unsigned.
- 1557. [func] Implement missing DNSSEC tests for
  - \* NOQNAME proof with wildcard answers.
  - \* NOWILDARD proof with NXDOMAIN.
 Cache and return NOQNAME with wildcard answers.
- 1556. [bug] nsupdate now treats all names as fully qualified. [RT #6427]
- 1555. [func] 'rrset-order cyclic' no longer has a random starting point per query. [RT #7572]

(continues on next page)

(continued from previous page)

1554. [bug] dig, host, nslookup failed when no nameservers were specified in /etc/resolv.conf. [RT #8232]
1553. [bug] The windows socket code could stop accepting connections. [RT #10115]
1552. [bug] Accept NOTIFY requests from mapped masters if matched-mapped is set. [RT #10049]
1551. [port] Open "/dev/null" before calling chroot().
1550. [port] Call tzset(), if available, before calling chroot().
1549. [func] named-checkzone can now write out the zone contents in a easily parsable format (-D and -o).
1548. [bug] When parsing APL records it was possible to silently accept out of range ADDRESSFAMILY values. [RT #9979]
1547. [bug] Named wasted memory recording duplicate lame zone entries. [RT #9341]
1546. [bug] We were rejecting valid secure CNAME to negative answers.
1545. [bug] It was possible to leak memory if named was unable to bind to the specified transfer source and TSIG was being used. [RT #10120]
1544. [bug] Named would logged a single entry to a file despite it being over the specified size limit.
1543. [bug] Logging using "versions unlimited" did not work.
1542. [placeholder]
1541. [func] NSEC now uses new bitmap format.
1540. [bug] "rndc reload <dynamiczone>" was silently accepted. [RT #8934]
1539. [bug] Open UDP sockets for notify-source and transfer-source that use reserved ports at startup. [RT #9475]
1538. [placeholder] rt9997
1537. [func] New option "querylog". If set specify whether query logging is to be enabled or disabled at startup.
1536. [bug] Windows socket code failed to log a error description when returning ISC\_R\_UNEXPECTED. [RT #9998]

(continues on next page)

(continued from previous page)

- 1535. [placeholder]
- 1534. [bug] Race condition when priming cache. [RT #9940]
- 1533. [func] Warn if both "recursion no;" and "allow-recursion" are active. [RT #4389]
- 1532. [port] netbsd: the configure test for <sys/sysctl.h> requires <sys/param.h>.
- 1531. [port] AIX more libtool fixes.
- 1530. [bug] It was possible to trigger a INSIST() failure if a slave master file was removed at just the correct moment. [RT #9462]
- 1529. [bug] "notify explicit;" failed to log that NOTIFY messages were being sent for the zone. [RT #9442]
- 1528. [cleanup] Simplify some dns\_name\_ functions based on the deprecation of bitstring labels.
- 1527. [cleanup] Reduce the number of gettimeofday() calls without losing necessary timer granularity.
- 1526. [func] Implemented "additional section caching (or acache)", an internal cache framework for additional section content to improve response performance. Several configuration options were provided to control the behavior.
- 1525. [bug] dns\_cache\_create() could trigger a REQUIRE failure in isc\_mem\_put() during error cleanup. [RT #9360]
- 1524. [port] AIX needs to be able to resolve all symbols when creating shared libraries (--with-libtool).
- 1523. [bug] Fix race condition in rbtodb. [RT #9189]
- 1522. [bug] dns\_db\_findnode() relax the requirements on 'name'. [RT #9286]
- 1521. [bug] dns\_view\_createresolver() failed to check the result from isc\_mem\_create(). [RT #9294]
- 1520. [protocol] Add SSHFP (SSH Finger Print) type.
- 1519. [bug] dnssec-signzone:nsec\_setbit() computed the wrong length of the new bitmap.
- 1518. [bug] dns\_nsec\_buildrdata(), and hence dns\_nsec\_build(),

(continues on next page)

(continued from previous page)

		contained a off-by-one error when working out the number of octets in the bitmap.
1517.	[port]	Support for IPv6 interface scanning on HP/UX and TrueUNIX 5.1.
1516.	[func]	Roll the DNSSEC types to RRSIG, NSEC and DNSKEY.
1515.	[func]	Allow transfer source to be set in a server statement. [RT #6496]
1514.	[bug]	named: isc_hash_destroy() was being called too early. [RT #9160]
1513.	[doc]	Add "US" to root-delegation-only exclude list.
1512.	[bug]	Extend the delegation-only logging to return query type, class and responding nameserver.
1511.	[bug]	delegation-only was generating false positives on negative answers from sub-zones.
1510.	[func]	New view option "root-delegation-only". Apply delegation-only check to all TLDs and root. Note there are some TLDs that are NOT delegation only (e.g. DE, LV, US and MUSEUM) these can be excluded from the checks by using exclude.  <pre> root-delegation-only exclude {     "DE"; "LV"; "US"; "MUSEUM"; }; </pre>
1509.	[bug]	Hint zones should accept delegation-only. Forward zone should not accept delegation-only.
1508.	[bug]	Don't apply delegation-only checks to answers from forwarders.
1507.	[bug]	Handle BIND 8 style returns to NS queries to parents when making delegation-only checks.
1506.	[bug]	Wrong return type for dns_view_isdelegationonly().
1505.	[bug]	Uninitialized rdataset in sdb. [RT #8750]
1504.	[func]	New zone type "delegation-only".
1503.	[port]	win32: install libeay32.dll outside of system32.
1502.	[bug]	nsupdate: adjust timeouts for UPDATE requests over TCP.
1501.	[func]	Allow TCP queue length to be specified via

(continues on next page)

(continued from previous page)

		named.conf, tcp-listen-queue.
1500.	[bug]	host failed to lookup MX records. Also look up AAAA records.

1499.	[bug]	isc_random need to be seeded better if arc4random() is not used.
1498.	[port]	bsdos: 5.x support.
1497.	[placeholder]	
1496.	[port]	test for pthread_attr_setstacksize().
1495.	[cleanup]	Replace hash functions with universal hash.
1494.	[security]	Turn on RSA BLINDING as a precaution.
1493.	[placeholder]	
1492.	[cleanup]	Preserve rwlock quota context when upgrading / downgrading. [RT #5599]
1491.	[bug]	dns_master_dump*() would produce extraneous \$ORIGIN lines. [RT #6206]
1490.	[bug]	Accept reading state as well as working state in ns_client_next(). [RT #6813]
1489.	[compat]	Treat 'allow-update' on slave zones as a warning. [RT #3469]
1488.	[bug]	Don't override trust levels for glue addresses. [RT #5764]
1487.	[bug]	A REQUIRE() failure could be triggered if a zone was queued for transfer and the zone was then removed. [RT #6189]
1486.	[bug]	isc_print_snprintf() '%' consumed one too many format characters. [RT #8230]
1485.	[bug]	gen failed to handle high type values. [RT #6225]
1484.	[bug]	The number of records reported after a AXFR was wrong. [RT #6229]
1483.	[bug]	dig axfr failed if the message id in the answer failed to match that in the request. Only the id in the first message is required to match. [RT #8138]
1482.	[bug]	named could fail to start if the kernel supports

(continues on next page)

(continued from previous page)

		IPv6 but no interfaces are configured. Similarly for IPv4. [RT #6229]
1481.	[bug]	Refresh and stub queries failed to use masters keys if specified. [RT #7391]
1480.	[bug]	Provide replay protection for rndc commands. Full replay protection requires both rndc and named to be updated. Partial replay protection (limited exposure after restart) is provided if just named is updated.
1479.	[bug]	cfg_create_tuple() failed to handle out of memory cleanup. parse_list() would leak memory on syntax errors.
1478.	[port]	ifconfig.sh didn't account for other virtual interfaces. It now takes a optional argument to specify the first interface number. [RT #3907]
1477.	[bug]	memory leak using stub zones and TSIG.
1476.	[placeholder]	
1475.	[port]	Probe for old sprintf().
1474.	[port]	Provide strtoul() and memmove() for platforms without them.
1473.	[bug]	create_map() and create_string() failed to handle out of memory cleanup. [RT #6813]
1472.	[contrib]	idnkit-1.0 from JPNIC, replaces mdnkit.
1471.	[bug]	libbind: updated to BIND 8.4.0.
1470.	[bug]	Incorrect length passed to snprintf. [RT #5966]
1469.	[func]	Log end of outgoing zone transfer at same level as the start of transfer is logged. [RT #4441]
1468.	[func]	Internal zones are no longer counted for 'rndc status'. [RT #4706]
1467.	[func]	\$GENERATES now supports optional class and ttl.
1466.	[bug]	lwresd configuration errors resulted in memory and lock leaks. [RT #5228]
1465.	[bug]	isc_base64_decodestring() and isc_base64_tobuffer() failed to check that trailing bits were zero allowing some invalid base64 strings to be accepted. [RT #5397]

(continues on next page)

(continued from previous page)

- 1464. [bug] Preserve "out of zone" data for outgoing zone transfers. [RT #5192]
- 1463. [bug] dns\_rdata\_from{wire,struct}() failed to catch bad NXT bit maps. [RT #5577]
- 1462. [bug] parse\_sizeval() failed to check the token type. [RT #5586]
- 1461. [bug] Remove deadlock from rbtodb code. [RT #5599]
- 1460. [bug] inet\_pton() failed to reject certain malformed IPv6 literals.
- 1459. [placeholder]
- 1458. [cleanup] sprintf() -> snprintf().
- 1457. [port] Provide strlcat() and strlcpy() for platforms without them.
- 1456. [contrib] gen-data-queryperf.py from Stephane Bortzmeyer.
- 1455. [bug] <netaddr> missing from server grammar in doc/misc/options. [RT #5616]
- 1454. [port] Use getifaddrs() if available for interface scanning. --disable-getifaddrs to override. Glibc currently has a getifaddrs() that does not support IPv6. Use --enable-getifaddrs=glibc to force the use of this version under linux machines.
- 1453. [doc] ARM: \$GENERATE example wasn't accurate. [RT #5298]
- 1452. [placeholder]
- 1451. [bug] rndc-confgen didn't exit with a error code for all failures. [RT #5209]
- 1450. [bug] Fetching expired glue failed under certain circumstances. [RT #5124]
- 1449. [bug] query\_addbestns() didn't handle running out of memory gracefully.
- 1448. [bug] Handle empty wildcards labels.
- 1447. [bug] We were casting (unsigned int) to and from (void \*). rdataset->private4 is now rdataset->privateuint4 to reflect a type change.

(continues on next page)

(continued from previous page)

1446.	[func]	Implemented undocumented alternate transfer sources from BIND 8. See use-alt-transfer-source, alt-transfer-source and alt-transfer-source-v6.  SECURITY: use-alt-transfer-source is ENABLED unless you are using views. This may cause a security risk resulting in accidental disclosure of wrong zone content if the master supplying different source content based on IP address. If you are not certain ISC recommends setting use-alt-transfer-source no;
1445.	[bug]	DNS_ADBFIND_STARTATROOT broke stub zones. This has been replaced with DNS_ADBFIND_STARTATZONE which causes the search to start using the closest zone.
1444.	[func]	dns_view_findzonecut2() allows you to specify if the cache should be searched for zone cuts.
1443.	[func]	Masters lists can now be specified and referenced in zone masters clauses and other masters lists.
1442.	[func]	New functions for manipulating port lists: dns_portlist_create(), dns_portlist_add(), dns_portlist_remove(), dns_portlist_match(), dns_portlist_attach() and dns_portlist_detach().
1441.	[func]	It is now possible to tell dig to bind to a specific source port.
1440.	[func]	It is now possible to tell named to avoid using certain source ports (avoid-v4-udp-ports, avoid-v6-udp-ports).
1439.	[bug]	Named could return NOERROR with certain NOTIFY failures. Return NOTAUTH if the NOTIFY zone is not being served.
1438.	[func]	Log TSIG (if any) when logging NOTIFY requests.
1437.	[bug]	Leave space for stdio to work in. [RT #5033]
1436.	[func]	dns_zonemgr_resumexfrs() can be used to restart stalled transfers.
1435.	[bug]	zmgr_resume_xfrs() was being called read locked rather than write locked. zmgr_resume_xfrs() was not being called if the zone was being shutdown.
1434.	[bug]	"rndc reconfig" failed to initiate the initial zone transfer of new slave zones.

(continues on next page)

(continued from previous page)

- 1433. [bug] named could trigger a REQUIRE failure if it could not get a file descriptor when attempting to write a master file. [RT #4347]
- 1432. [func] The advertised EDNS UDP buffer size can now be set via named.conf (edns-udp-size).
- 1431. [bug] isc\_print\_snprintf() "%s" with precision could walk off end of argument. [RT #5191]
- 1430. [port] linux: IPv6 interface scanning support.
- 1429. [bug] Prevent the cache getting locked to old servers.
- 1428. [placeholder]
- 1427. [bug] Race condition in adb with threaded build.
- 1426. [placeholder]
- 1425. [port] linux/libbind: define \_\_USE\_MISC when testing \*\_r() function prototypes in netdb.h. [RT #4921]
- 1424. [bug] EDNS version not being correctly printed.
- 1423. [contrib] queryperf: added A6 and SRV.
- 1422. [func] Log name/type/class when denying a query. [RT #4663]
- 1421. [func] Differentiate updates that don't succeed due to prerequisites (unsuccessful) vs other reasons (failed).
- 1420. [port] solaris: work around gcc optimizer bug.
- 1419. [port] openbsd: use /dev/arandom. [RT #4950]
- 1418. [bug] 'rndc reconfig' did not cause new slaves to load.
- 1417. [func] ID.SERVER/CHAOS is now a built in zone. See "server-id" for how to configure.
- 1416. [bug] Empty node should return NOERROR NODATA, not NXDOMAIN. [RT #4715]
- 1415. [func] DS TTL now derived from NS ttl. NXT TTL now derived from SOA MINIMUM.
- 1414. [func] Support for KSK flag.
- 1413. [func] Explicitly request the (re-)generation of DS records from keysets (dnssec-signzone -g).

(continues on next page)

(continued from previous page)

- 1412. [func] You can now specify servers to be tried if a nameserver has IPv6 address and you only support IPv4 or the reverse. See dual-stack-servers.
- 1411. [bug] empty nodes should stop wildcard matches. [RT #4802]
- 1410. [func] Handle records that live in the parent zone, e.g. DS.
- 1409. [bug] DS should have attribute DNS\_RDATA\_TYPE\_ATTR\_DNSSEC.
- 1408. [bug] "make distclean" was not complete. [RT #4700]
- 1407. [bug] lfsr incorrectly implements the shift register. [RT #4617]
- 1406. [bug] dispatch initializes one of the LFSR's with a incorrect polynomial. [RT #4617]
- 1405. [func] Use arc4random() if available.
- 1404. [bug] libbind: ns\_name\_ntol() could overwrite a zero length buffer.
- 1403. [func] dnssec-signzone, dnssec-keygen, dnssec-makekeyset dnssec-signkey now report their version in the usage message.
- 1402. [cleanup] A6 has been moved to experimental and is no longer fully supported.
- 1401. [bug] adb wasn't clearing state when the timer expired.
- 1400. [bug] Block the addition of wildcard NS records by IXFR or UPDATE. [RT #3502]
- 1399. [bug] Use serial number arithmetic when testing SIG timestamps. [RT #4268]
- 1398. [doc] ARM: notify-also should have been also-notify. [RT #4345]
- 1397. [maint] J.ROOT-SERVERS.NET is now 192.58.128.30.
- 1396. [func] dnssec-signzone: adjust the default signing time by 1 hour to allow for clock skew.
- 1395. [port] OpenSSL 0.9.7 defines CRYPTO\_LOCK\_ENGINE but doesn't have a working implementation. [RT #4079]
- 1394. [func] It is now possible to check if a particular element is in a acl. Remove duplicate entries from the localnets

(continues on next page)

(continued from previous page)

		acl.
1393.	[port]	Bind to individual IPv6 interfaces if IPV6_IPV6ONLY is not available in the kernel to prevent accidentally listening on IPv4 interfaces.
1392.	[bug]	named-checkzone: update usage.
1391.	[func]	Add support for IPv6 scoped addresses in named.
1390.	[func]	host now supports ixfr.
1389.	[bug]	named could fail to rotate long log files. [RT #3666]
1388.	[port]	irix: check for sys/sysctl.h and NET_RT_IFLIST before defining HAVE_IFLIST_SYSCTL. [RT #3770]
1387.	[bug]	named could crash due to an access to invalid memory space (which caused an assertion failure) in incremental cleaning. [RT #3588]
1386.	[bug]	named-checkzone -z stopped on errors in a zone. [RT #3653]
1385.	[bug]	Setting serial-query-rate to 10 would trigger a REQUIRE failure.
1384.	[bug]	host was incompatible with BIND 8 in its exit code and in the output with the -l option. [RT #3536]
1383.	[func]	Track the serial number in a IXFR response and log if a mismatch occurs. This is a more specific error than "not exact". [RT #3445]
1382.	[bug]	make install failed with --enable-libbind. [RT #3656]
1381.	[bug]	named failed to correctly process answers that contained DNAME records where the resulting CNAME resulted in a negative answer.
1380.	[func]	'rndc recursing' dump recursing queries to 'recursing-file = "named.recursing";'.
1379.	[func]	'rndc status' now reports tcp and recursion quota states.
1378.	[func]	Improved positive feedback for 'rndc {reload refresh}.
1377.	[func]	dns_zone_load{new}() now reports if the zone was loaded, queued for loading to up to date.
1376.	[func]	New function dns_zone_logc() to log to specified

(continues on next page)

(continued from previous page)

		category.
1375.	[func]	'rndc dumpdb' now dumps the adb cache along with the data cache.
1374.	[func]	dns_adb_dump() now logs the lame zones associated with each server.
1373.	[bug]	Recovery from expired glue failed under certain circumstances.
1372.	[bug]	named crashes with an assertion failure on exit when sharing the same port for listening and querying, and changing listening addresses several times. [RT #3509]
1371.	[bug]	notify-source-v6, transfer-source-v6 and query-source-v6 with explicit addresses and using the same ports as named was listening on could interfere with named's ability to answer queries sent to those addresses.
1370.	[bug]	dig '+[no]recurse' was incorrectly documented.
1369.	[bug]	Adding an NS record as the lexicographically last record in a secure zone didn't work.
1368.	[func]	remove support for bitstring labels.
1367.	[func]	Use response times to select forwarders.
1366.	[contrib]	queryperf usage was incomplete. Add '-h' for help.
1365.	[func]	"localhost" and "localnets" acls now include IPv6 addresses / prefixes.
1364.	[func]	Log file name when unable to open memory statistics and dump database files. [RT #3437]
1363.	[func]	Listen-on-v6 now supports specific addresses.
1362.	[bug]	remove IFF_RUNNING test when scanning interfaces.
1361.	[func]	log the reason for rejecting a server when resolving queries.
1360.	[bug]	--enable-libbind would fail when not built in the source tree for certain OS's.
1359.	[security]	Support patches OpenSSL libraries. <a href="http://www.cert.org/advisories/CA-2002-23.html">http://www.cert.org/advisories/CA-2002-23.html</a>
1358.	[bug]	It was possible to trigger a INSIST when debugging

(continues on next page)

(continued from previous page)

		large dynamic updates. [RT #3390]
1357.	[bug]	nsupdate was extremely wasteful of memory.
1356.	[tuning]	Reduce the number of events / quantum for zone tasks.
1355.	[bug]	Fix DNSSEC wildcard proof for CNAME/DNAME.
1354.	[doc]	lwres man pages had illegal nroff.
1353.	[contrib]	sdb/ldap to version 0.9.
1352.	[bug]	dig, host, nslookup when falling back to TCP use the current search entry (if any). [RT #3374]
1351.	[bug]	lwres_getipnodebyname() returned the wrong name when given a IPv4 literal, af=AF_INET6 and AI_MAPPED was set.
1350.	[bug]	dns_name_fromtext() failed to handle too many labels gracefully.
1349.	[security]	Minimum OpenSSL version now 0.9.6e (was 0.9.5a). <a href="http://www.cert.org/advisories/CA-2002-23.html">http://www.cert.org/advisories/CA-2002-23.html</a>
1348.	[port]	win32: Rewrote code to use I/O Completion Ports in socket.c and eliminating a host of socket errors. Performance is enhanced.
1347.	[placeholder]	
1346.	[placeholder]	
1345.	[port]	Use a explicit -Wformat with gcc. Not all versions include it in -Wall.
1344.	[func]	Log if the serial number on the master has gone backwards. If you have multiple machines specified in the masters clause you may want to set 'multi-master yes;' to suppress this warning.
1343.	[func]	Log successful notifies received (info). Adjust log level for failed notifies to notice.
1342.	[func]	Log remote address with TCP dispatch failures.
1341.	[func]	Allow a rate limiter to be stalled.
1340.	[bug]	Delay and spread out the startup refresh load.
1339.	[func]	dig, host and nslookup now use IP6.ARPA for nibble

(continues on next page)

(continued from previous page)

		lookups. Bit string lookups are no longer attempted.
1338.	[placeholder]	
1337.	[placeholder]	
1336.	[func]	Nibble lookups under IP6.ARPA are now supported by <code>dns_byaddr_create()</code> . <code>dns_byaddr_createptrname()</code> is deprecated, use <code>dns_byaddr_createptrname2()</code> instead.
1335.	[bug]	When performing a nonexistence proof, the validator should discard parent NXTs from higher in the DNS.
1334.	[bug]	When signing/verifying rdatasets, duplicate rdatas need to be suppressed.
1333.	[contrib]	<code>queryperf</code> now reports a summary of returned rcodes (-c), rcodes are printed in mnemonic form (-v).
1332.	[func]	Report the current serial with periodic commits when rolling forward the journal.
1331.	[func]	Generate DNSSEC wildcard proofs.
1330.	[bug]	When processing events (non-threaded) only allow the task one chance to use to use its quantum.
1329.	[func]	<code>named-checkzone</code> will now check if nameservers that appear to be IP addresses. Available modes "fail", "warn" (default) and "ignore" the results of the check.
1328.	[bug]	The validator could incorrectly verify an invalid negative proof.
1327.	[bug]	The validator would incorrectly mark data as insecure when seeing a bogus signature before a correct signature.
1326.	[bug]	DNAME/CNAME signatures were not being cached when validation was not being performed. [RT #3284]
1325.	[bug]	If the <code>tcpquota</code> was exhausted it was possible to trigger a <code>INSIST()</code> failure.
1324.	[port]	darwin: <code>ifconfig.sh</code> now supports darwin.
1323.	[port]	linux: Slackware 4.0 needs <code>&lt;asm/unistd.h&gt;</code> . [RT #3205]
1322.	[bug]	<code>dnssec-signzone</code> usage message was misleading.
1321.	[bug]	If the last RRset in a zone is glue, <code>dnssec-signzone</code>

(continues on next page)

(continued from previous page)

		would incorrectly duplicate its output and sign it.
1320.	[doc]	query-source-v6 was missing from options section. [RT #3218]
1319.	[func]	libbind: log attempts to exploit #1318.
1318.	[bug]	libbind: Remote buffer overrun.
1317.	[port]	libbind: TrueUNIX 5.1 does not like __align as a element name.
1316.	[bug]	libbind: gethostans() could get out of sync parsing the response if there was a very long CNAME chain.
1315.	[bug]	Options should apply to the internal _bind view.
1314.	[port]	Handle ECONNRESET from sendmsg() [unix].
1313.	[func]	Query log now says if the query was signed (S) or if EDNS was used (E).
1312.	[func]	Log TSIG key used w/ outgoing zone transfers.
1311.	[bug]	lwres_getrrsetbyname leaked memory. [RT #3159]
1310.	[bug]	'rndc stop' failed to cause zones to be flushed sometimes. [RT #3157]
1309.	[func]	Log that a zone transfer was covered by a TSIG.
1308.	[func]	DS (delegation signer) support.
1307.	[bug]	nsupdate: allow white space base64 key data.
1306.	[bug]	Badly encoded LOC record when the size, horizontal precision or vertical precision was 0.1m.
1305.	[bug]	Document that internal zones are included in the rndc status results.
1304.	[func]	New function: dns_zone_name().
1303.	[func]	Option 'flush-zones-on-shutdown <boolean>';.
1302.	[func]	Extended rndc dumpdb to support dumping of zones and view selection: 'dumpdb [-all -zones -cache] [view]';.
1301.	[func]	New category 'update-security';.
1300.	[port]	Compaq Trucluster support.

(continues on next page)

(continued from previous page)

- 1299. [bug] Set AI\_ADDRCONFIG when looking up addresses via getaddrinfo() (affects dig, host, nslookup, rndc and nsupdate).
- 1298. [bug] The CINCLUDES macro in lib/dns/sec/dst/Makefile could be left with a trailing "\" after configure has been run.
- 1297. [port] linux: make handling EINVAL from socket() no longer conditional on #ifdef LINUX.
- 1296. [bug] isc\_log\_closefilelogs() needed to lock the log context.
- 1295. [bug] isc\_log\_setdebuglevel() needed to lock the log context.
- 1294. [func] libbind: no longer attempts bit string labels for IPv6 reverse resolution. Try IP6.ARPA then IP6.INT for nibble style resolution.
- 1293. [func] Entropy can now be retrieved from EGDs. [RT #2438]
- 1292. [func] Enable IPv6 support when using ioctl style interface scanning and OS supports SIOCGLIFADDR using struct if\_laddrreq.
- 1291. [func] Enable IPv6 support when using sysctl style interface scanning.
- 1290. [func] "dig axfr" now reports the number of messages as well as the number of records.
- 1289. [port] See if -ldl is required for OpenSSL? [RT #2672]
- 1288. [bug] Adjusted REQUIRE's in lib/dns/name.c to better reflect written requirements.
- 1287. [bug] REQUIRE that DNS\_DBADD\_MERGE only be set when adding a rdataset to a zone db in the rbtdb implementation of addrdataset.
- 1286. [bug] dns\_name\_lowercase() enforce requirement that target != NULL or name->buffer != NULL.
- 1285. [func] lwres: probe the system to see what address families are currently in use.
- 1284. [bug] The RTT estimate on unused servers was not aged. [RT #2569]
- 1283. [func] Use "dataready" accept filter if available.

(continues on next page)

(continued from previous page)

- 1282. [port] libbind: hpux 11.11 interface scanning.
- 1281. [func] Log zone when unable to get private keys to update zone. Log zone when NXT records are missing from secure zone.
- 1280. [bug] libbind: escape '(' and ')' when converting to presentation form.
- 1279. [port] Darwin uses (unsigned long) for size\_t. [RT #2590]
- 1278. [func] dig: now supports +[no]cl +[no]ttlid.
- 1277. [func] You can now create your own customized printing styles: dns\_master\_stylecreate() and dns\_master\_styledestroy().
- 1276. [bug] libbind: const pointer conflicts in res\_debug.c.
- 1275. [port] libbind: hpux: treat all hpux systems as BIG\_ENDIAN.
- 1274. [bug] Memory leak in lwres\_gnbarequest\_parse().
- 1273. [port] libbind: solaris: 64 bit binary compatibility.
- 1272. [contrib] Berkeley DB 4.0 sdb implementation from Nuno Miguel Rodrigues <nmr@co.sapo.pt>.
- 1271. [bug] "recursion available: {denied,approved}" was too confusing.
- 1270. [bug] Check that system inet\_pton() and inet\_ntop() support AF\_INET6.
- 1269. [port] Openserver: ifconfig.sh support.
- 1268. [port] Openserver: the value FD\_SETSIZE depends on whether <sys/param.h> is included or not. Be consistent.
- 1267. [func] isc\_file\_openunique() now creates file using mode 0666 rather than 0600.
- 1266. [bug] ISC\_LINK\_INIT, ISC\_LINK\_UNLINK, ISC\_LIST\_DEQUEUE, \_\_ISC\_LINK\_UNLINKUNSAFE and \_\_ISC\_LIST\_DEQUEUEUNSAFE are not C++ compatible, use \*\_TYPE versions instead.
- 1265. [bug] libbind: LINK\_INIT and UNLINK were not compatible with C++, use LINK\_INIT\_TYPE and UNLINK\_TYPE instead.
- 1264. [placeholder]

(continues on next page)

(continued from previous page)

1263.	[bug]	Reference after free error if <code>dns_dispatchmgr_create()</code> failed.
1262.	[bug]	<code>ns_server_destroy()</code> failed to set <code>*serverp</code> to <code>NULL</code> .
1261.	[func]	libbind: <code>ns_sign2()</code> and <code>ns_sign_tcp()</code> now provide support for compressed TSIG owner names.
1260.	[func]	libbind: <code>res_update</code> can now update IPv6 servers, new function <code>res_findzonecut2()</code> .
1259.	[bug]	libbind: <code>get_salen()</code> IPv6 support was broken for OSs w/o <code>sa_len</code> .
1258.	[bug]	libbind: <code>res_nametotype()</code> and <code>res_nametoclass()</code> were broken.
1257.	[bug]	Failure to write pid-file should not be fatal on reload. [RT #2861]
1256.	[contrib]	'queryperf' now has EDNS (-e) + DNSSEC DO (-D) support.
1255.	[bug]	When verifying that an NXT proves nonexistence, check the rcode of the message and only do the matching NXT check. That is, for NXDOMAIN responses, check that the name is in the range between the NXT owner and next name, and for NOERROR NODATA responses, check that the type is not present in the NXT bitmap.
1254.	[func]	preferred-glue option from BIND 8.3.
1253.	[bug]	The dnssec system test failed to remove the correct files.
1252.	[bug]	Dig, host and nslookup were not checking the address the answer was coming from against the address it was sent to. [RT #2692]
1251.	[port]	win32: a make file contained absolute version specific references.
1250.	[func]	Nsupdate will report the address the update was sent to.

1249.	[bug]	Missing masters clause was not handled gracefully. [RT #2703]
1248.	[bug]	DESTDIR was not being propagated between makes.
1247.	[bug]	Don't reset the interface index for link/site local addresses. [RT #2576]

(continues on next page)

(continued from previous page)

- 1246. [func] New functions `isc_sockaddr_issitelocal()`,  
`isc_sockaddr_islinklocal()`, `isc_netaddr_issitelocal()`  
and `isc_netaddr_islinklocal()`.
- 1245. [bug] Treat `ENOBUFS`, `ENOMEM` and `ENFILE` as soft errors for  
`accept()`.
- 1244. [bug] Receiving a TCP message from a blackhole address would  
prevent further messages being received over that  
interface.
- 1243. [bug] It was possible to trigger a `REQUIRE()` in  
`dns_message_findtype()`. [RT #2659]
- 1242. [bug] `named-checkzone` failed if a journal existed. [RT #2657]
- 1241. [bug] Drop received UDP messages with a zero source port  
as these are invariably forged. [RT #2621]
- 1240. [bug] It was possible to leak zone references by  
specifying an incorrect zone to `rndc`.
- 1239. [bug] Under certain circumstances `named` could continue to  
use a name after it had been freed triggering  
`INSIST()` failures. [RT #2614]
- 1238. [bug] It is possible to lockup the server when shutting down  
if notifies were being processed. [RT #2591]
- 1237. [bug] `nslookup: "set q=type" failed.`
- 1236. [bug] `dns_rdata{class,type}_fromtext()` didn't handle non  
NULL terminated text regions. [RT #2588]
- 1235. [func] Report 'out of memory' errors from `openssl`.
- 1234. [bug] `contrib/sdb: 'zonetodb' failed to call`  
`dns_result_register()`. `DNS_R_SEENINCLUDE` should not  
be fatal.
- 1233. [bug] The flags field of a KEY record can be expressed in  
hex as well as decimal.
- 1232. [bug] `unix/errno2result()` didn't handle `EADDRNOTAVAIL`.
- 1231. [port] `HPUX 11.11 recvmsg()` can return spurious `EADDRNOTAVAIL`.
- 1230. [bug] `isccc_cc_isreply()` and `isccc_cc_isack()` were broken.
- 1229. [bug] `named` would crash if it received a TSIG signed  
query as part of an AXFR response. [RT #2570]

(continues on next page)

(continued from previous page)

- 1228. [bug] 'make install' did not depend on 'make all'. [RT #2559]
- 1227. [bug] dns\_lex\_getmastertoken() now returns ISC\_R\_BADNUMBER if a number was expected and some other token was found. [RT #2532]
- 1226. [func] Use EDNS for zone refresh queries. [RT #2551]
- 1225. [func] dns\_message\_setopt() no longer requires that dns\_message\_renderbegin() to have been called.
- 1224. [bug] 'rrset-order' and 'sortlist' should be additive not exclusive.
- 1223. [func] 'rrset-order' partially works 'cyclic' and 'random' are supported.
- 1222. [bug] Specifying 'port \*' did not always result in a system selected (non-reserved) port being used. [RT #2537]
- 1221. [bug] Zone types 'master', 'slave' and 'stub' were not being compared case insensitively. [RT #2542]
- 1220. [func] Support for APL rdata type.
- 1219. [func] Named now reports the TSIG extended error code when signature verification fails. [RT #1651]
- 1218. [bug] Named incorrectly returned SERVFAIL rather than NOTAUTH when there was a TSIG BADTIME error. [RT #2519]
- 1217. [func] Report locations of previous key definition when a duplicate is detected.
- 1216. [bug] Multiple server clauses for the same server were not reported. [RT #2514]
- 1215. [port] solaris: add support to ifconfig.sh for x86 2.5.1
- 1214. [bug] Win32: isc\_file\_renameunique() could leave zero length files behind.
- 1213. [func] Report view associated with client if it is not a standard view (\_default or \_bind).
- 1212. [port] libbind: 64k answer buffers were causing stack space to be exceeded for certain OS. Use heap space instead.
- 1211. [bug] dns\_name\_fromtext() incorrectly handled certain valid octal bitlabels. [RT #2483]
- 1210. [bug] libbind: getnameinfo() failed to lookup IPv4 mapped /

(continues on next page)

(continued from previous page)

- compatible addresses. [RT #2461]

1209. [bug] Dig, host, nslookup were not checking the message ids on the responses. [RT #2454]
- 1208. [bug] dns\_master\_load\*() failed to log a error message if an error was detected when parsing the owner name of a record. [RT #2448]
- 1207. [bug] libbind: getaddrinfo() could call freeaddrinfo() with an invalid pointer.
- 1206. [bug] SERVFAIL and NOTIMP responses to an EDNS query should trigger a non-EDNS retry.
- 1205. [bug] OPT, TSIG and TKEY cannot be used to set the "class" of the message. [RT #2449]
- 1204. [bug] libbind: res\_nupdate() failed to update the name server addresses before sending the update.
- 1203. [func] Report locations of previous acl and zone definitions when a duplicate is detected.
- 1202. [func] New functions: cfg\_obj\_line() and cfg\_obj\_file().
- 1201. [bug] Require that if 'callbacks' is passed to dns\_rdata\_fromtext(), callbacks->error and callbacks->warn are initialized.
- 1200. [bug] Log 'errno' that we are unable to convert to isc\_result\_t. [RT #2404]
- 1199. [doc] ARM reference to RFC 2157 should have been RFC 1918. [RT #2436]
- 1198. [bug] OPT printing style was not consistent with the way the header fields are printed. The DO bit was not reported if set. Report if any of the MBZ bits are set.
- 1197. [bug] Attempts to define the same acl multiple times were not detected.
- 1196. [contrib] update mdkit to 2.2.3.
- 1195. [bug] Attempts to redefine builtin acls should be caught. [RT #2403]
- 1194. [bug] Not all duplicate zone definitions were being detected at the named.conf checking stage. [RT #2431]
- 1193. [bug] dig +besteffort parsing didn't handle packet

(continues on next page)

(continued from previous page)

		truncation. <code>dns_message_parse()</code> has new flag <code>DNS_MESSAGE_IGNORETRUNCATION</code> .
1192.	[bug]	The seconds fields in LOC records were restricted to three decimal places. More decimal places should be allowed but warned about.
1191.	[bug]	A dynamic update removing the last non-apex name in a secure zone would fail. [RT #2399]
1190.	[func]	Add the "rndc freeze" and "rndc unfreeze" commands. [RT #2394]
1189.	[bug]	On some systems, <code>malloc(0)</code> returns NULL, which could cause the caller to report an out of memory error. [RT #2398]
1188.	[bug]	Dynamic updates of a signed zone would fail if some of the zone private keys were unavailable.
1187.	[bug]	named was incorrectly returning DNSSEC records in negative responses when the DO bit was not set.
1186.	[bug]	<code>isc_hex_tobuffer(,,length = 0)</code> failed to unget the EOL token when reading to end of line.
1185.	[bug]	libbind: don't assume <code>statp-&gt;_u._ext.ext</code> is valid unless <code>RES_INIT</code> is set when calling <code>res_*init()</code> .
1184.	[bug]	libbind: call <code>res_ndestroy()</code> if <code>RES_INIT</code> is set when <code>res_*init()</code> is called.
1183.	[bug]	Handle <code>ENOSR</code> error when writing to the internal control pipe. [RT #2395]
1182.	[bug]	The server could throw an assertion failure when constructing a negative response packet.
1181.	[func]	Add the "key-directory" configuration statement, which allows the server to look for online signing keys in alternate directories.
1180.	[func]	<code>dnssec-keygen</code> should always generate keys with protocol 3 (DNSSEC), since it's less confusing that way.
1179.	[func]	Add <code>SIG(0)</code> support to <code>nsupdate</code> .
1178.	[bug]	Follow and cache (if appropriate) A6 and other data chains to completion in the additional section.
1177.	[func]	Report view when loading zones if it is not a

(continues on next page)

(continued from previous page)

- standard view (`_default` or `_bind`). [RT #2270]
- 1176. [doc] Document that allow-v6-synthesis is only performed for clients that are supplied recursive service. [RT #2260]
- 1175. [bug] named-checkzone and named-checkconf failed to call `dns_result_register()` at startup which could result in runtime exceptions when printing "out of memory" errors. [RT #2335]
- 1174. [bug] Win32: add `WSAECONNRESET` to the expected errors from `connect()`. [RT #2308]
- 1173. [bug] Potential memory leaks in `isc_log_create()` and `isc_log_settag()`. [RT #2336]
- 1172. [doc] Add `CERT`, `GPOS`, `KX`, `NAPTR`, `NSAP`, `PX` and `TXT` to table of RR types in ARM.
- 1171. [func] Added function `isc_region_compare()`, updated files in `lib/dns` to use this function instead of local one.
- 1170. [bug] Don't attempt to print the token when a I/O error occurs when parsing `named.conf`. [RT #2275]
- 1169. [func] Identify recursive queries in the query log.
- 1168. [bug] Empty `also-notify` clauses were not handled. [RT #2309]
- 1167. [contrib] `nslint-2.1a3` (from author).
- 1166. [bug] "Not Implemented" should be reported as `NOTIMP`, not `NOTIMPL`. [RT #2281]
- 1165. [bug] We were rejecting `notify-source{-v6}` in zone clauses.
- 1164. [bug] Empty masters clauses in slave / stub zones were not handled gracefully. [RT #2262]
- 1163. [func] `isc_time_formattimestamp()` now includes the year.
- 1162. [bug] The `allow-notify` option was not accepted in slave zone statements.
- 1161. [bug] `named-checkzone` looped on unbalanced brackets. [RT #2248]
- 1160. [bug] Generating Diffie-Hellman keys longer than 1024 bits could fail. [RT #2241]
- 1159. [bug] `MD` and `MF` are not permitted to be loaded by `RFC1123`.

(continues on next page)

(continued from previous page)

- 1158. [func] Report the client's address when logging notify messages.
- 1157. [func] match-clients and match-destinations now accept keys. [RT #2045]
- 1156. [port] The configure test for strsep() incorrectly succeeded on certain patched versions of AIX 4.3.3. [RT #2190]
- 1155. [func] Recover from master files being removed from under us.
- 1154. [bug] Don't attempt to obtain the netmask of a interface if there is no address configured. [RT #2176]
- 1153. [func] 'rndc {stop|halt} -p' now reports the process id of the instance of named being shutdown.
- 1152. [bug] libbind: read buffer overflows.
- 1151. [bug] nslookup failed to check that the arguments to the port, timeout, and retry options were valid integers and in range. [RT #2099]
- 1150. [bug] named incorrectly accepted TTL values containing plus or minus signs, such as 1d+1h-1s.
- 1149. [func] New function isc\_parse\_uint32().
- 1148. [func] 'rndc-confgen -a' now provides positive feedback.
- 1147. [func] Set IPV6\_V6ONLY on IPv6 sockets if supported by the OS. listen-on-v6 { any; }; should no longer result in IPv4 queries be accepted. Similarly control { inet :: ... }; should no longer result in IPv4 connections being accepted. This can be overridden at compile time by defining ISC\_ALLOW\_MAPPED=1.
- 1146. [func] Allow IPV6\_IPV6ONLY to be set/cleared on a socket if supported by the OS by a new function isc\_socket\_ipv6only().
- 1145. [func] "host" no longer reports a NOERROR/NODATA response by printing nothing. [RT #2065]
- 1144. [bug] rndc-confgen would crash if both the -a and -t options were specified. [RT #2159]

(continues on next page)

(continued from previous page)

- 1143. [bug] When a trusted-keys statement was present and named was built without crypto support, it would leak memory.
- 1142. [bug] dnssec-signzone would fail to delete temporary files in some failure cases. [RT #2144]
- 1141. [bug] When named rejected a control message, it would leak a file descriptor and memory. It would also fail to respond, causing rndc to hang. [RT #2139, #2164]
- 1140. [bug] rndc-confgen did not accept IPv6 addresses as arguments to the -s option. [RT #2138]
- 1139. [func] It is now possible to flush a given name from the cache(s) via 'rndc flushname name [view]'. [RT #2051]
- 1138. [func] It is now possible to flush a given name from the cache by calling the new function dns\_cache\_flushname().
- 1137. [func] It is now possible to flush a given name from the ADB by calling the new function dns\_adb\_flushname().
- 1136. [bug] CNAME records synthesized from DNAMEs did not have a TTL of zero as required by RFC2672. [RT #2129]
- 1135. [func] You can now override the default syslog() facility for named/lwresd at compile time. [RT #1982]
- 1134. [bug] Multi-threaded servers could deadlock in ferror() when reloading zone files. [RT #1951, #1998]
- 1133. [bug] IN6\_IS\_ADDR\_LOOPBACK was not portably defined on platforms without IN6\_IS\_ADDR\_LOOPBACK. [RT #2106]
- 1132. [func] Improve UPDATE prerequisite failure diagnostic messages.
- 1131. [bug] The match-destinations view option did not work with IPv6 destinations. [RT #2073, #2074]
- 1130. [bug] Log messages reporting an out-of-range serial number did not include the out-of-range number but the following token. [RT #2076]
- 1129. [bug] Multi-threaded servers could crash under heavy resolution load due to a race condition. [RT #2018]
- 1128. [func] sdb drivers can now provide RR data in either text or wire format, the latter using the new functions dns\_sdb\_putrrdata() and dns\_sdb\_putnamedrrdata().

(continues on next page)

(continued from previous page)

- 1127. [func] rndc: If the server to contact has multiple addresses, try all of them.
- 1126. [bug] The server could access a freed event if shut down while a client start event was pending delivery. [RT #2061]
- 1125. [bug] rndc: -k option was missing from usage message. [RT #2057]
- 1124. [doc] dig: +[no]dnssec, +[no]besteffort and +[no]fail are now documented. [RT #2052]
- 1123. [bug] dig +[no]fail did not match description. [RT #2052]
- 1122. [tuning] Resolution timeout reduced from 90 to 30 seconds. [RT #2046]
- 1121. [bug] The server could attempt to access a NULL zone table if shut down while resolving. [RT #1587, #2054]
- 1120. [bug] Errors in options were not fatal. [RT #2002]
- 1119. [func] Added support in Win32 for NTFS file/directory ACL's for access control.
- 1118. [bug] On multi-threaded servers, a race condition could cause an assertion failure in resolver.c during resolver shutdown. [RT #2029]
- 1117. [port] The configure check for in6addr\_loopback incorrectly succeeded on AIX 4.3 when compiling with -O2 because the test code was optimized away. [RT #2016]
- 1116. [bug] Setting transfers in a server clause, transfers-in, or transfers-per-ns to a value greater than 2147483647 disabled transfers. [RT #2002]
- 1115. [func] Set maximum values for cleaning-interval, heartbeat-interval, interface-interval, max-transfer-idle-in, max-transfer-idle-out, max-transfer-time-in, max-transfer-time-out, statistics-interval of 28 days and sig-validity-interval of 3660 days. [RT #2002]
- 1114. [port] Ignore more accept() errors. [RT #2021]
- 1113. [bug] The allow-update-forwarding option was ignored when specified in a view. [RT #2014]

(continues on next page)

(continued from previous page)

- 1112. [placeholder]
- 1111. [bug] Multi-threaded servers could deadlock processing recursive queries due to a locking hierarchy violation in adb.c. [RT #2017]
- 1110. [bug] dig should only accept valid abbreviations of +options. [RT #2003]
- 1109. [bug] nsupdate accepted illegal ttl values.
- 1108. [bug] On Win32, rndc was hanging when named was not running due to failure to select for exceptional conditions in select(). [RT #1870]
- 1107. [bug] nsupdate could catch an assertion failure if an invalid domain name was given as the argument to the "zone" command.
- 1106. [bug] After seeing an out of range TTL, nsupdate would treat all TTLs as out of range. [RT #2001]
- 1105. [port] OpenUNIX 8 enable threads by default. [RT #1970]
- 1104. [bug] Invalid arguments to the transfer-format option could cause an assertion failure. [RT #1995]
- 1103. [port] OpenUNIX 8 support (ifconfig.sh). [RT #1970]
- 1102. [doc] Note that query logging is enabled by directing the queries category to a channel.
- 1101. [bug] Array bounds read error in lwres\_gai\_strerror.
- 1100. [bug] libbind: DNSSEC key ids were computed incorrectly.
- 1099. [cleanup] libbind: defining REPORT\_ERRORS in lib/bind/dst caused compile time errors.
- 1098. [bug] libbind: HMAC-MD5 key files are now mode 0600.
- 1097. [func] libbind: RES\_PRF\_TRUNC for dig.
- 1096. [func] libbind: "DNSSEC OK" (DO) support.
- 1095. [func] libbind: resolver option: no-tld-query. disables trying unqualified as a tld. no\_tld\_query is also supported for FreeBSD compatibility.
- 1094. [func] libbind: add support gcc's format string checking.

(continues on next page)

(continued from previous page)

1093.	[doc]	libbind: miscellaneous nroff fixes.
1092.	[bug]	libbind: get*by*() failed to check if res_init() had been called.
1091.	[bug]	libbind: misplaced va_end().
1090.	[bug]	libbind: dns_ho.c:add_hostent() was not returning the amount of memory consumed resulting in garbage address being returned. Alignment calculations were wasting space. We weren't suppressing duplicate addresses.
1089.	[func]	libbind: inet_{cidr,net}_{pton,ntop}() now have IPv6 support.
1088.	[port]	libbind: MPE/iX C.70 (incomplete)
1087.	[bug]	libbind: struct __res_state too large on 64 bit arch.
1086.	[port]	libbind: sunos: old sprintf.
1085.	[port]	libbind: solaris: sys_nerr and sys_errlist do not exist when compiling in 64 bit mode.
1084.	[cleanup]	libbind: gai_strerror() rewritten.
1083.	[bug]	The default control channel listened on the wildcard address, not the loopback as documented. [RT #1975]
1082.	[bug]	The -g option to named incorrectly caused logging to be sent to syslog in addition to stderr. [RT #1974]
1081.	[bug]	Multicast queries were incorrectly identified based on the source address, not the destination address.
1080.	[bug]	BIND 8 compatibility: accept bare IP prefixes as the second element of a two-element top level sort list statement. [RT #1964]
1079.	[bug]	BIND 8 compatibility: accept bare elements at top level of sort list treating them as if they were a single element list. [RT #1963]
1078.	[bug]	We failed to correct bad tv_usec values in one case. [RT #1966]
1077.	[func]	Do not accept further recursive clients when the total number of recursive lookups being

(continues on next page)

(continued from previous page)

		processed exceeds max-recursive-clients, even if some of the lookups are internally generated. [RT #1915, #1938]
1076.	[bug]	A badly defined global key could trigger an assertion on load/reload if views were used. [RT #1947]
1075.	[bug]	Out-of-range network prefix lengths were not reported. [RT #1954]
1074.	[bug]	Running out of memory in dump_rdataset() could cause an assertion failure. [RT #1946]
1073.	[bug]	The ADB cache cleaning should also be space driven. [RT #1915, #1938]
1072.	[bug]	The TCP client quota could be exceeded when recursion occurred. [RT #1937]
1071.	[bug]	Sockets listening for TCP DNS connections specified an excessive listen backlog. [RT #1937]
1070.	[bug]	Copy DNSSEC OK (DO) to response as specified by draft-ietf-dnsext-dnssec-okbit-03.txt.
1069.	[placeholder]	
1068.	[bug]	errno could be overwritten by catgets(). [RT #1921]
1067.	[func]	Allow quotas to be soft, isc_quota_soft().
1066.	[bug]	Provide a thread safe wrapper for strerror(). [RT #1689]
1065.	[func]	Runtime support to select new / old style interface scanning using ioctl's.
1064.	[bug]	Do not shut down active network interfaces if we are unable to scan the interface list. [RT #1921]
1063.	[bug]	libbind: "make install" was failing on IRIX. [RT #1919]
1062.	[bug]	If the control channel listener socket was shut down before server exit, the listener object could be freed twice. [RT #1916]
1061.	[bug]	If periodic cache cleaning happened to start while cleaning due to reaching the configured maximum cache size was in progress, the server could catch an assertion failure. [RT #1912]

(continues on next page)

(continued from previous page)

- 1060. [func] Move refresh, stub and notify UDP retry processing into dns\_request.
- 1059. [func] dns\_request now support will now retry UDP queries, dns\_request\_createvia2() and dns\_request\_createraw2().
- 1058. [func] Limited lifetime ticker timers are now available, isc\_timertype\_limited.
- 1057. [bug] Reloading the server after adding a "file" clause to a zone statement could cause the server to crash due to a typo in change 1016.
- 1056. [bug] Rndc could catch an assertion failure on SIGINT due to an uninitialized variable. [RT #1908]
- 1055. [func] Version and hostname queries can now be disabled using "version none;" and "hostname none;", respectively.
- 1054. [bug] On Win32, cfg\_categories and cfg\_modules need to be exported from the libisccfg DLL.
- 1053. [bug] Dig did not increase its timeout when receiving AXFRs unless the +time option was used. [RT #1904]
- 1052. [bug] Journals were not being created in binary mode resulting in "journal format not recognized" error under Win32. [RT #1889]
- 1051. [bug] Do not ignore a network interface completely just because it has a noncontiguous netmask. Instead, omit it from the localnets ACL and issue a warning. [RT #1891]
- 1050. [bug] Log messages reporting malformed IP addresses in address lists such as that of the forwarders option failed to include the correct error code, file name, and line number. [RT #1890]
- 1049. [func] "pid-file none;" will disable writing a pid file. [RT #1848]
- 1048. [bug] Servers built with -DISC\_MEM\_USE\_INTERNAL\_MALLOC=1 didn't work.
- 1047. [bug] named was incorrectly refusing all requests signed with a TSIG key derived from an unsigned TKEY negotiation with a NOERROR response. [RT #1886]
- 1046. [bug] The help message for the --with-openssl configure option was inaccurate. [RT #1880]

(continues on next page)

(continued from previous page)

- 1045. [bug] It was possible to skip saving glue for a nameserver for a stub zone.
- 1044. [bug] Specifying allow-transfer, notify-source, or notify-source-v6 in a stub zone was not treated as an error.
- 1043. [bug] Specifying a transfer-source or transfer-source-v6 option in the zone statement for a master zone was not treated as an error. [RT #1876]
- 1042. [bug] The "config" logging category did not work properly. [RT #1873]
- 1041. [bug] Dig/host/nslookup could catch an assertion failure on SIGINT due to an uninitialized variable. [RT #1867]
- 1040. [bug] Multiple listen-on-v6 options with different ports were not accepted. [RT #1875]
- 1039. [bug] Negative responses with CNAMEs in the answer section were cached incorrectly. [RT #1862]
- 1038. [bug] In servers configured with a tkey-domain option, TKEY queries with an owner name other than the root could cause an assertion failure. [RT #1866, #1869]
- 1037. [bug] Negative responses whose authority section contain SOA or NS records whose owner names are not equal equal to or parents of the query name should be rejected. [RT #1862]
- 1036. [func] Silently drop requests received via multicast as long as there is no final multicast DNS standard.
- 1035. [bug] If we respond to multicast queries (which we currently do not), respond from a unicast address as specified in RFC 1123. [RT #137]
- 1034. [bug] Ignore the RD bit on multicast queries as specified in RFC 1123. [RT #137]
- 1033. [bug] Always respond to requests with an unsupported opcode with NOTIMP, even if we don't have a matching view or cannot determine the class.
- 1032. [func] hostname.bind/txt/chaos now returns the name of the machine hosting the nameserver. This is useful in diagnosing problems with anycast servers.
- 1031. [bug] libbind.a: isc\_\_gettimeofday() infinite recursion.

(continues on next page)

(continued from previous page)

		[RT #1858]
1030.	[bug]	On systems with no resolv.conf file, nsupdate exited with an error rather than defaulting to using the loopback address. [RT #1836]
1029.	[bug]	Some named.conf errors did not cause the loading of the configuration file to return a failure status even though they were logged. [RT #1847]
1028.	[bug]	On Win32, dig/host/nslookup looked for resolv.conf in the wrong directory. [RT #1833]
1027.	[bug]	RRs having the reserved type 0 should be rejected. [RT #1471]
1026.	[placeholder]	
1025.	[bug]	Don't use multicast addresses to resolve iterative queries. [RT #101]
1024.	[port]	Compilation failed on HP-UX 11.11 due to incompatible use of the SIOCGLIFCONF macro name. [RT #1831]
1023.	[func]	Accept hints without TTLs.
1022.	[bug]	Don't report empty root hints as "extra data". [RT #1802]
1021.	[bug]	On Win32, log message timestamps were one month later than they should have been, and the server would exhibit unspecified behavior in December.
1020.	[bug]	IXFR log messages did not distinguish between true IXFRs, AXFR-style IXFRs, and mere version polls. [RT #1811]
1019.	[bug]	The value of the lame-ttl option was limited to 18000 seconds, not 1800 seconds as documented. [RT #1803]
1018.	[bug]	The default log channel was not always initialized correctly. [RT #1813]
1017.	[bug]	When specifying TSIG keys to dig and nsupdate using the -k option, they must be HMAC-MD5 keys. [RT #1810]
1016.	[bug]	Slave zones with no backup file were re-transferred on every server reload.
1015.	[bug]	Log channels that had a "versions" option but no "size" option failed to create numbered log

(continues on next page)

(continued from previous page)

		files. [RT #1783]
1014.	[bug]	Some queries would cause statistics counters to increment more than once or not at all. [RT #1321]
1013.	[bug]	It was possible to cancel a query twice when marking a server as bogus or by having a blackhole acl. [RT #1776]
1012.	[bug]	The -p option to named did not behave as documented.
1011.	[cleanup]	Removed isc_dir_current().
1010.	[bug]	The server could attempt to execute a command channel command after initiating server shutdown, causing an assertion failure. [RT #1766]
1009.	[port]	OpenUNIX 8 support. [RT #1728]
1008.	[port]	libtool.m4, ltmain.sh from libtool-1.4.2.
1007.	[port]	config.guess, config.sub from autoconf-2.52.
1006.	[bug]	If a KEY RR was found missing during DNSSEC validation, an assertion failure could subsequently be triggered in the resolver. [RT #1763]
1005.	[bug]	Don't copy nonzero RCODEs from request to response. [RT #1765]
1004.	[port]	Deal with recvfrom() returning EHOSTDOWN. [RT #1770]
1003.	[func]	Add the +retry option to dig.
1002.	[bug]	When reporting an unknown class name in named.conf, including the file name and line number. [RT #1759]
1001.	[bug]	win32 socket code doio_recv was not catching a WSACONNRESET error when a client was timing out the request and closing its socket. [RT #1745]
1000.	[bug]	BIND 8 compatibility: accept "HESIOD" as an alias for class "HS". [RT #1759]
999.	[func]	"rndc retransfer zone [class [view]]" added. [RT #1752]
998.	[func]	named-checkzone now has arguments to specify the chroot directory (-t) and working directory (-w). [RT #1755]
997.	[func]	Add support for RSA-SHA1 keys (RFC3110).

(continues on next page)

(continued from previous page)

- 996. [func] Issue warning if the configuration filename contains the chroot path.
- 995. [bug] dig, host, nslookup: using a raw IPv6 address as a target address should be fatal on a IPv4 only system.
- 994. [func] Treat non-authoritative responses to queries for type NS as referrals even if the NS records are in the answer section, because BIND 8 servers incorrectly send them that way. This is necessary for DNSSEC validation of the NS records of a secure zone to succeed when the parent is a BIND 8 server. [RT #1706]
- 993. [func] dig: -v now reports the version.
- 992. [doc] dig: ~/.digrc is now documented.
- 991. [func] Lower UDP refresh timeout messages to level debug 1.
- 990. [bug] The rndc-confgen man page was not installed.
- 989. [bug] Report filename if \$INCLUDE fails for file related errors. [RT #1736]
- 988. [bug] 'additional-from-auth no;' did not work reliably in the case of queries answered from the cache. [RT #1436]
- 987. [bug] "dig -help" didn't show "+[no]stats".
- 986. [bug] "dig +noall" failed to clear stats and command printing.
- 985. [func] Consider network interfaces to be up iff they have a nonzero IP address rather than based on the IFF\_UP flag. [RT #1160]
- 984. [bug] Multi-threading should be enabled by default on Solaris 2.7 and newer, but it wasn't.
- 983. [func] The server now supports generating IXFR difference sequences for non-dynamic zones by comparing zone versions, when enabled using the new config option "ixfr-from-differences". [RT #1727]
- 982. [func] If "memstatistics-file" is set in options the memory statistics will be written to it.
- 981. [func] The dnssec tools can now take multiple '-r randomfile' arguments.

(continues on next page)

(continued from previous page)

- 980. [bug] Incoming zone transfers restarting after an error could trigger an assertion failure. [RT #1692]
- 979. [func] Incremental master file dumping. `dns_master_dumpinc()`, `dns_master_dumptostreaminc()`, `dns_dumpctx_attach()`, `dns_dumpctx_detach()`, `dns_dumpctx_cancel()`, `dns_dumpctx_db()` and `dns_dumpctx_version()`.
- 978. [bug] `dns_db_attachversion()` had an invalid REQUIRE() condition.
- 977. [bug] Improve "not at top of zone" error message.
- 976. [func] `named-checkconf` can now test load master zones (`named-checkconf -z`). [RT #1468]
- 975. [bug] "max-cache-size default;" as a view option caused an assertion failure.
- 974. [bug] "max-cache-size unlimited;" as a global option was not accepted.
- 973. [bug] Failed to log the question name when logging: "bad zone transfer request: non-authoritative zone (NOTAUTH)".
- 972. [bug] The file modification time code in `zone.c` was using the wrong epoch. [RT #1667]
- 971. [placeholder]
- 970. [func] 'max-journal-size' can now be used to set a target size for a journal.
- 969. [func] `dig` now supports the undocumented `dig 8` feature of allowing arbitrary labels, not just dotted decimal quads, with the `-x` option. This can be used to conveniently look up RFC2317 names as in "`dig -x 10.0.0.0-127`". [RT #827, #1576, #1598]
- 968. [bug] On win32, the `isc_time_now()` function was unnecessarily calling `strtime()`. [RT #1671]
- 967. [bug] On win32, the link for `bindevt` was not including the required resource file to enable the event viewer to interpret the error messages in the event log, [RT #1668]
- 966. [placeholder]
- 965. [bug] Including data other than root server NS and A

(continues on next page)

(continued from previous page)

		records in the root hint file could cause a rbtodb node reference leak. [RT #1581, #1618]
964.	[func]	Warn if data other than root server NS and A records are found in the root hint file. [RT #1581, #1618]
963.	[bug]	Bad ISC_LANG_ENDDECLS. [RT #1645]
962.	[bug]	libbind: bad "#undef", don't attempt to install non-existent nlist.h. [RT #1640]
961.	[bug]	Tried to use a IPV6 feature when ISC_PLATFORM_HAVEIPV6 was not defined. [RT #1482]
960.	[port]	liblwres failed to build on systems with support for getrrsetbyname() in the OS. [RT #1592]
959.	[port]	On FreeBSD, determine the number of CPUs by calling sysctlbyname(). [RT #1584]
958.	[port]	ssize_t is not available on all platforms. [RT #1607]
957.	[bug]	sys/select.h inclusion was broken on older platforms. [RT #1607]
956.	[bug]	ns_g_autorndcfile changed to ns_g_keyfile in named/win32/os.c due to code changes in change #953. win32 .make file for rndc-confgen updated to add include path for os.h header.

		--- 9.2.0rc1 released ---
955.	[bug]	When using views, the zone's class was not being inherited from the view's class. [RT #1583]
954.	[bug]	When requesting AXFRs or IXFRs using dig, host, or nslookup, the RD bit should not be set as zone transfers are inherently non-recursive. [RT #1575]
953.	[func]	The /var/run/named.key file from change #843 has been replaced by /etc/rndc.key. Both named and rndc will look for this file and use it to configure a default control channel key if not already configured using a different method (rndc.conf / controls). Unlike named.key, rndc.key is not created automatically; it must be created by manually running "rndc-confgen -a".
952.	[bug]	The server required manual intervention to serve the affected zones if it died between creating a journal and committing the first change to it.

(continues on next page)

(continued from previous page)

- 951. [bug] CFLAGS was not passed to the linker when linking some of the test programs under bin/tests. [RT #1555].
- 950. [bug] Explicit TTLs did not properly override \$TTL due to a bug in change 834. [RT #1558]
- 949. [bug] host was unable to print records larger than 512 bytes. [RT #1557]

--- 9.2.0b2 released ---

- 948. [port] Integrated support for building on Windows NT / Windows 2000.
- 947. [bug] dns\_rdata\_soa\_t had a badly named element "mname" which was really the RNAME field from RFC1035. To avoid confusion and silent errors that would occur if the "origin" and "mname" elements were given their correct names "mname" and "rname" respectively, the "mname" element is renamed to "contact".
- 946. [cleanup] doc/misc/options is now machine-generated from the configuration parser syntax tables, and therefore more likely to be correct.
- 945. [func] Add the new view-specific options "match-destinations" and "match-recursive-only".
- 944. [func] Check for expired signatures on load.
- 943. [bug] The server could crash when receiving a command via rndc if the configuration file listed only nonexistent keys in the controls statement. [RT #1530]
- 942. [port] libbind: GETNETBYADDR\_ADDR\_T was not correctly defined on some platforms.
- 941. [bug] The configuration checker crashed if a slave zone didn't contain a masters statement. [RT #1514]
- 940. [bug] Double zone locking failure on error path. [RT #1510]

--- 9.2.0b1 released ---

- 939. [port] Add the --disable-linux-caps option to configure for systems that manage capabilities outside of named. [RT #1503]
- 938. [placeholder]

(continues on next page)

(continued from previous page)

- 937. [bug] A race when shutting down a zone could trigger a INSIST() failure. [RT #1034]
- 936. [func] Warn about IPv4 addresses that are not complete dotted quads. [RT #1084]
- 935. [bug] inet\_pton failed to reject leading zeros.
- 934. [port] Deal with systems where accept() spuriously returns ECONNRESET.
- 933. [bug] configure failed doing libbind on platforms not supported by BIND 8. [RT #1496]

--- 9.2.0a3 released ---

- 932. [bug] Use INSTALL\_SCRIPT, not INSTALL\_PROGRAM, when installing isc-config.sh. [RT #198, #1466]
- 931. [bug] The controls statement only attempted to verify messages using the first key in the key list. (9.2.0a1/a2 only).
- 930. [func] Query performance testing tool added as contrib/queryperf.
- 929. [placeholder]
- 928. [bug] nsupdate would send empty update packets if the send (or empty line) command was run after another send but before any new updates or prerequisites were specified. It should simply ignore this command.
- 927. [bug] Don't hold the zone lock for the entire dump to disk. [RT #1423]
- 926. [bug] The resolver could deadlock with the ADB when shutting down (multi-threaded builds only). [RT #1324]
- 925. [cleanup] Remove openssl from the distribution; require that --with-openssl be specified if DNSSEC is needed.
- 924. [port] Extend support for pre-RFC2133 IPv6 implementation. [RT #987]
- 923. [bug] Multiline TSIG secrets (and other multiline strings) were not accepted in named.conf. [RT #1469]

(continues on next page)

(continued from previous page)

- 922. [func] Added two new lwres\_getrrsetbyname() result codes, ERR\_NONAME and ERR\_NODATA.
- 921. [bug] lwres returned an incorrect error code if it received a truncated message.
- 920. [func] Increase the lwres receive buffer size to 16K. [RT #1451]
- 919. [placeholder]
- 918. [func] In nsupdate, TSIG errors are no longer treated as fatal errors.
- 917. [func] New nsupdate command 'key', allowing TSIG keys to be specified in the nsupdate command stream rather than the command line.
- 916. [bug] Specifying type ixfr to dig without specifying a serial number failed in unexpected ways.
- 915. [func] The named-checkconf and named-checkzone programs now have a '-v' option for printing their version. [RT #1151]
- 914. [bug] Global 'server' statements were rejected when using views, even though they were accepted in 9.1. [RT #1368]
- 913. [bug] Cache cleaning was not sufficiently aggressive. [RT #1441, #1444]
- 912. [bug] Attempts to set the 'additional-from-cache' or 'additional-from-auth' option to 'no' in a server with recursion enabled will now be ignored and cause a warning message. [RT #1145]
- 911. [placeholder]
- 910. [port] Some pre-RFC2133 IPv6 implementations do not define IN6ADDR\_ANY\_INIT. [RT #1416]
- 909. [placeholder]
- 908. [func] New program, rndc-confgen, to simplify setting up rndc.
- 907. [func] The ability to get entropy from either the random device, a user-provided file or from the keyboard was migrated from the DNSSEC tools to libisc as isc\_entropy\_usebestsource().

(continues on next page)

(continued from previous page)

906.	[port]	Separated the system independent portion of lib/isc/unix/entropy.c into lib/isc/entropy.c and added lib/isc/win32/entropy.c.
905.	[bug]	Configuring a forward "zone" for the root domain did not work. [RT #1418]
904.	[bug]	The server would leak memory if attempting to use an expired TSIG key. [RT #1406]
903.	[bug]	dig should not crash when receiving a TCP packet of length 0.
902.	[bug]	The -d option was ignored if both -t and -g were also specified.
901.	[placeholder]	
900.	[bug]	A config.guess update changed the system identification string of FreeBSD systems; configure and bin/tests/system/ifconfig.sh now recognize the new string.

--- 9.2.0a2 released ---		
899.	[bug]	lib/dns/soa.c failed to compile on many platforms due to inappropriate use of a void value. [RT #1372, #1373, #1386, #1387, #1395]
898.	[bug]	"dig" failed to set a nonzero exit status on UDP query timeout. [RT #1323]
897.	[bug]	A config.guess update changed the system identification string of UnixWare systems; configure now recognizes the new string.
896.	[bug]	If a configuration file is set on named's command line and it has a relative pathname, the current directory (after any possible jailing resulting from named -t) will be prepended to it so that reloading works properly even when a directory option is present.
895.	[func]	New function, isc_dir_current(), akin to POSIX's getcwd().
894.	[bug]	When using the DNSSEC tools, a message intended to warn when the keyboard was being used because of the lack of a suitable random device was not being printed.
893.	[func]	Removed isc_file_test() and added isc_file_exists() for the basic functionality that was being added with isc_file_test().

(continues on next page)

(continued from previous page)

- 892. [placeholder]
- 891. [bug] Return an error when a SIG(0) signed response to an unsigned query is seen. This should actually do the verification, but it's not currently possible. [RT #1391]
- 890. [cleanup] The man pages no longer require the mandoc macros and should now format cleanly using most versions of nroff, and HTML versions of the man pages have been added. Both are generated from DocBook source.
- 889. [port] Eliminated blank lines before .TH in nroff man pages since they cause problems with some versions of nroff. [RT #1390]
- 888. [bug] Don't die when using TKEY to delete a nonexistent TSIG key. [RT #1392]
- 887. [port] Detect broken compilers that can't call static functions from inline functions. [RT #1212]
- 886. [placeholder]
- 885. [placeholder]
- 884. [placeholder]
- 883. [placeholder]
- 882. [placeholder]
- 881. [placeholder]
- 880. [placeholder]
- 879. [placeholder]
- 878. [placeholder]
- 877. [placeholder]
- 876. [placeholder]
- 875. [placeholder]
- 874. [placeholder]
- 873. [placeholder]
- 872. [placeholder]

(continues on next page)

(continued from previous page)

- 871. [placeholder]
- 870. [placeholder]
- 869. [placeholder]
- 868. [placeholder]
- 867. [placeholder]
- 866. [func] Close debug only file channels when debug is set to zero. [RT #1246]
- 865. [bug] The new configuration parser did not allow the optional debug level in a "severity debug" clause of a logging channel to be omitted. This is now allowed and treated as "severity debug 1;" like it does in BIND 8.2.4, not as "severity debug 0;" like it did in BIND 9.1. [RT #1367]
- 864. [cleanup] Multi-threading is now enabled by default on OSF1, Solaris 2.7 and newer, AIX, IRIX, and HP-UX.
- 863. [bug] If an error occurred while an outgoing zone transfer was starting up, the server could access a domain name that had already been freed when logging a message saying that the transfer was starting. [RT #1383]
- 862. [bug] Use after realloc(), non portable pointer arithmetic in grmerge().
- 861. [port] Add support for Mac OS X, by making it equivalent to Darwin. This was derived from the config.guess file shipped with Mac OS X. [RT #1355]
- 860. [func] Drop cross class glue in zone transfers.
- 859. [bug] Cache cleaning now won't swamp the CPU if there is a persistent over limit condition.
- 858. [func] isc\_mem\_setwater() no longer requires that when the callback function is non-NULL then its hi\_water argument must be greater than its lo\_water argument (they can now be equal) or that they be non-zero.
- 857. [cleanup] Use ISC\_MAGIC() to define all magic numbers for structs, for our friends in EBCDIC-land.
- 856. [func] Allow partial rdatasets to be returned in answer and

(continues on next page)

(continued from previous page)

		authority sections to help non-TCP capable clients recover from truncation. [RT #1301]
855.	[bug]	Stop spurious "using RFC 1035 TTL semantics" warnings.
854.	[bug]	The config parser didn't properly handle config options that were specified in units of time other than seconds. [RT #1372]
853.	[bug]	configure_view_acl() failed to detach existing acls. [RT #1374]
852.	[bug]	Handle responses from servers which do not know about IXFR.
851.	[cleanup]	The obsolete support-ixfr option was not properly ignored.

		--- 9.2.0a1 released ---
850.	[bug]	dns_rbt_findnode() would not find nodes that were split on a bitstring label somewhere other than in the last label of the node. [RT #1351]
849.	[func]	<isc/net.h> will ensure INADDR_LOOPBACK is defined.
848.	[func]	A minimum max-cache-size of two megabytes is enforced by the cache cleaner.
847.	[func]	Added isc_file_test(), which currently only has some very basic functionality to test for the existence of a file, whether a pathname is absolute, or whether a pathname is the fundamental representation of the current directory. It is intended that this function can be expanded to test other things a programmer might want to know about a file.
846.	[func]	A non-zero 'param' to dst_key_generate() when making an hmac-md5 key means that good entropy is not required.
845.	[bug]	The access rights on the public file of a symmetric key are now restricted as soon as the file is opened, rather than after it has been written and closed.
844.	[func]	<isc/net.h> will ensure INADDR_LOOPBACK is defined, just as <lwres/net.h> does.
843.	[func]	If no controls statement is present in named.conf, or if any inet phrase of a controls statement is lacking a keys clause, then a key will be automatically generated by named and an rndc.conf-style file named named.key will be written that uses it. rndc

(continues on next page)

(continued from previous page)

		will use this file only if its normal configuration file, or one provided on the command line, does not exist.
842.	[func]	'rndc flush' now takes an optional view.
841.	[bug]	When sdb modules were not declared threadsafe, their create and destroy functions were not serialized.
840.	[bug]	The config file parser could print the wrong file name if an error was detected after an included file was parsed. [RT #1353]
839.	[func]	Dump packets for which there was no view or that the class could not be determined to category "unmatched".
838.	[port]	UnixWare 7.x.x is now supported by bin/tests/system/ifconfig.sh.
837.	[cleanup]	Multi-threading is now enabled by default only on OSF1, Solaris 2.7 and newer, and AIX.
836.	[func]	Upgraded libtool to 1.4.
835.	[bug]	The dispatcher could enter a busy loop if it got an I/O error receiving on a UDP socket. [RT #1293]
834.	[func]	Accept (but warn about) master files beginning with an SOA record without an explicit TTL field and lacking a \$TTL directive, by using the SOA MINTTL as a default TTL. This is for backwards compatibility with old versions of BIND 8, which accepted such files without warning although they are illegal according to RFC1035.
833.	[cleanup]	Moved dns_soa_*() from <dns/journal.h> to <dns/soa.h>, and extended them to support all the integer-valued fields of the SOA RR.
832.	[bug]	The default location for named.conf in named-checkconf should depend on --sysconfdir like it does in named. [RT #1258]
831.	[placeholder]	
830.	[func]	Implement 'rndc status'.
829.	[bug]	The DNS_R_ZONECUT result code should only be returned when an ANY query is made with DNS_DBFIND_GLUEOK set. In all other ANY query cases, returning the delegation is better.

(continues on next page)

(continued from previous page)

- 828. [bug] The errno value from recvfrom() could be overwritten by logging code. [RT #1293]
- 827. [bug] When an IXFR protocol error occurs, the slave should retry with AXFR.
- 826. [bug] Some IXFR protocol errors were not detected.
- 825. [bug] zone.c:ns\_query() detached from the wrong zone reference. [RT #1264]
- 824. [bug] Correct line numbers reported by dns\_master\_load(). [RT #1263]
- 823. [func] The output of "dig -h" now goes to stdout so that it can easily be piped through "more". [RT #1254]
- 822. [bug] Sending nxrrset prerequisites would crash nsupdate. [RT #1248]
- 821. [bug] The program name used when logging to syslog should be stripped of leading path components. [RT #1178, #1232]
- 820. [bug] Name server address lookups failed to follow A6 chains into the glue of local authoritative zones.
- 819. [bug] In certain cases, the resolver's attempts to restart an address lookup at the root could cause the fetch to deadlock (with itself) instead of restarting. [RT #1225]
- 818. [bug] Certain pathological responses to ANY queries could cause an assertion failure. [RT #1218]
- 817. [func] Adjust timeouts for dialup zone queries.
- 816. [bug] Report potential problems with log file accessibility at configuration time, since such problems can't reliably be reported at the time they actually occur.
- 815. [bug] If a log file was specified with a path separator character (i.e. "/" ) in its name and the directory did not exist, the log file's name was treated as though it were the directory name. [RT #1189]
- 814. [bug] Socket objects left over from accept() failures were incorrectly destroyed, causing corruption of socket manager data structures.

(continues on next page)

(continued from previous page)

813. [bug] File descriptors exceeding FD\_SETSIZE were handled badly. [RT #1192]
812. [bug] dig sometimes printed incomplete IXFR responses due to an uninitialized variable. [RT #1188]
811. [bug] Parentheses were not quoted in zone dumps. [RT #1194]
810. [bug] The signer name in SIG records was not properly down-cased when signing/verifying records. [RT #1186]
809. [bug] Configuring a non-local address as a transfer-source could cause an assertion failure during load.
808. [func] Add 'rndc flush' to flush the server's cache.
807. [bug] When setting up TCP connections for incoming zone transfers, the transfer-source port was not ignored like it should be.
806. [bug] DNS\_R\_SEENINCLUDE was failing to propagate back up the calling stack to the zone maintenance level, causing zones to not reload when an included file was touched but the top-level zone file was not.
805. [bug] When using "forward only", missing root hints should not cause queries to fail. [RT #1143]
804. [bug] Attempting to obtain entropy could fail in some situations. This would be most common on systems with user-space threads. [RT #1131]
803. [bug] Treat all SIG queries as if they have the CD bit set, otherwise no data will be returned [RT #749]
802. [bug] DNSSEC key tags were computed incorrectly in almost all cases. [RT #1146]
801. [bug] nsupdate should treat lines beginning with ';' as comments. [RT #1139]
800. [bug] dnssec-signzone produced incorrect statistics for large zones. [RT #1133]
799. [bug] The ADB didn't find AAAA glue in a zone unless A6 glue was also present.
798. [bug] nsupdate should be able to reject bad input lines and continue. [RT #1130]
797. [func] Issue a warning if the 'directory' option contains a relative path. [RT #269]

(continues on next page)

(continued from previous page)

- 796. [func] When a size limit is associated with a log file, only roll it when the size is reached, not every time the log file is opened. [RT #1096]
- 795. [func] Add the +multiline option to dig. [RT #1095]
- 794. [func] Implement the "port" and "default-port" statements in rndc.conf.
- 793. [cleanup] The DNSSEC tools could create filenames that were illegal or contained shell meta-characters. They now use a different text encoding of names that doesn't have these problems. [RT #1101]
- 792. [cleanup] Replace the OMAPI command channel protocol with a simpler one.
- 791. [bug] The command channel now works over IPv6.
- 790. [bug] Wildcards created using dynamic update or IXFR could fail to match. [RT #1111]
- 789. [bug] The "localhost" and "localnets" ACLs did not match when used as the second element of a two-element sortlist item.
- 788. [func] Add the "match-mapped-addresses" option, which causes IPv6 v4mapped addresses to be treated as IPv4 addresses for the purpose of acl matching.
- 787. [bug] The DNSSEC tools failed to downcase domain names when mapping them into file names.
- 786. [bug] When DNSSEC signing/verifying data, owner names were not properly down-cased.
- 785. [bug] A race condition in the resolver could cause an assertion failure. [RT #673, #872, #1048]
- 784. [bug] nsupdate and other programs would not quit properly if some signals were blocked by the caller. [RT #1081]
- 783. [bug] Following CNAMEs could cause an assertion failure when either using an sdb database or under very rare conditions.
- 782. [func] Implement the "serial-query-rate" option.
- 781. [func] Avoid error packet loops by dropping duplicate FORMERR responses. [RT #1006]

(continues on next page)

(continued from previous page)

- 780. [bug] Error handling code dealing with out of memory or other rare errors could lead to assertion failures by calling functions on uninitialized names. [RT #1065]
- 779. [func] Added the "minimal-responses" option.
- 778. [bug] When starting cache cleaning, `cleaning_timer_action()` returned without first pausing the iterator, which could cause deadlock. [RT #998]
- 777. [bug] An empty forwarders list in a zone failed to override global forwarders. [RT #995]
- 776. [func] Improved error reporting in denied messages. [RT #252]
- 775. [placeholder]
- 774. [func] `max-cache-size` is implemented.
- 773. [func] Added `isc_rwlock_trylock()` to attempt to lock without blocking.
- 772. [bug] Owner names could be incorrectly omitted from cache dumps in the presence of negative caching entries. [RT #991]
- 771. [cleanup] TSIG errors related to unsynchronized clocks are logged better. [RT #919]
- 770. [func] Add the "edns yes\_or\_no" statement to the server clause. [RT #524]
- 769. [func] Improved error reporting when parsing rdata. [RT #740]
- 768. [bug] The server did not emit an SOA when a CNAME or DNAME chain ended in NXDOMAIN in an authoritative zone.
- 767. [placeholder]
- 766. [bug] A few cases in `query_find()` could leak `fname`. This would trigger the `mpctx->allocated == 0` assertion when the server exited. [RT #739, #776, #798, #812, #818, #821, #845, #892, #935, #966]
- 765. [func] ACL names are once again case insensitive, like in BIND 8. [RT #252]
- 764. [func] Configuration files now allow "include" directives in more places, such as inside the "view" statement. [RT #377, #728, #860]

(continues on next page)

(continued from previous page)

- 763. [func] Configuration files no longer have reserved words.  
[RT #731, #753]
- 762. [cleanup] The named.conf and rndc.conf file parsers have  
been completely rewritten.
- 761. [bug] \_REENTRANT was still defined when building with  
--disable-threads.
- 760. [contrib] Significant enhancements to the pgsqldb driver.
- 759. [bug] The resolver didn't turn off "avoid fetches" mode  
when restarting, possibly causing resolution  
to fail when it should not. This bug only affected  
platforms which support both IPv4 and IPv6. [RT #927]
- 758. [bug] The "avoid fetches" code did not treat negative  
cache entries correctly, causing fetches that would  
be useful to be avoided. This bug only affected  
platforms which support both IPv4 and IPv6. [RT #927]
- 757. [func] Log zone transfers.
- 756. [bug] dns\_zone\_load() could "return" success when no master  
file was configured.
- 755. [bug] Fix incorrectly formatted log messages in zone.c.
- 754. [bug] Certain failure conditions sending UDP packets  
could cause the server to retry the transmission  
indefinitely. [RT #902]
- 753. [bug] dig, host, and nslookup would fail to contact a  
remote server if getaddrinfo() returned an IPv6  
address on a system that doesn't support IPv6.  
[RT #917]
- 752. [func] Correct bad tv\_usec elements returned by  
gettimeofday().
- 751. [func] Log successful zone loads / transfers. [RT #898]
- 750. [bug] A query should not match a DNAME whose trust level  
is pending. [RT #916]
- 749. [bug] When a query matched a DNAME in a secure zone, the  
server did not return the signature of the DNAME.  
[RT #915]
- 748. [doc] List supported RFCs in doc/misc/rfc-compliance.  
[RT #781]

(continues on next page)

(continued from previous page)

- 747. [bug] The code to determine whether an IXFR was possible did not properly check for a database that could not have a journal. [RT #865, #908]
- 746. [bug] The sdb didn't clone rdatasets properly, causing a crash when the server followed delegations. [RT #905]
- 745. [func] Report the owner name of records that fail semantic checks while loading.
- 744. [bug] When returning DNS\_R\_CNAME or DNS\_R\_DNAME as the result of an ANY or SIG query, the resolver failed to setup the return event's rdatasets, causing an assertion failure in the query code. [RT #881]
- 743. [bug] Receiving a large number of certain malformed answers could cause named to stop responding. [RT #861]
- 742. [placeholder]
- 741. [port] Support openssl-engine. [RT #709]
- 740. [port] Handle openssl library mismatches slightly better.
- 739. [port] Look for /dev/random in configure, rather than assuming it will be there for only a predefined set of OSes.
- 738. [bug] If a non-threadsafe sdb driver supported AXFR and received an AXFR request, it would deadlock or die with an assertion failure. [RT #852]
- 737. [port] stdtime.c failed to compile on certain platforms.
- 736. [func] New functions isc\_task\_{begin,end}exclusive().
- 735. [doc] Add BIND 4 migration notes.
- 734. [bug] An attempt to re-lock the zone lock could occur if the server was shutdown during a zone transfer. [RT #830]
- 733. [bug] Reference counts of dns\_acl\_t objects need to be locked but were not. [RT #801, #821]
- 732. [bug] Glue with 0 TTL could also cause SERVFAIL. [RT #828]
- 731. [bug] Certain zone errors could cause named-checkzone to fail ungracefully. [RT #819]

(continues on next page)

(continued from previous page)

730.	[bug]	lwres_getaddrinfo() returns the correct result when it fails to contact a server. [RT #768]
729.	[port]	pthread_setconcurrency() needs to be called on Solaris.
728.	[bug]	Fix comment processing on master file directives. [RT #757]
727.	[port]	Work around OS bug where accept() succeeds but fails to fill in the peer address of the accepted connection, by treating it as an error rather than an assertion failure. [RT #809]
726.	[func]	Implement the "trace" and "notrace" commands in rndc.
725.	[bug]	Installing man pages could fail.
724.	[func]	New libisc functions isc_netaddr_any(), isc_netaddr_any6().
723.	[bug]	Referrals whose NS RRs had a 0 TTL caused the resolver to return DNS_R_SERVFAIL. [RT #783]
722.	[func]	Allow incremental loads to be canceled.
721.	[cleanup]	Load manager and dns_master_loadfilequota() are no more.
720.	[bug]	Server could enter infinite loop in dispatch.c:do_cancel(). [RT #733]
719.	[bug]	Rapid reloads could trigger an assertion failure. [RT #743, #763]
718.	[cleanup]	"internal" is no longer a reserved word in named.conf. [RT #753, #731]
717.	[bug]	Certain TKEY processing failure modes could reference an uninitialized variable, causing the server to crash. [RT #750]
716.	[bug]	The first line of a \$INCLUDE master file was lost if an origin was specified. [RT #744]
715.	[bug]	Resolving some A6 chains could cause an assertion failure in adb.c. [RT #738]
714.	[bug]	Preserve interval timers across reloads unless changed. [RT #729]
713.	[func]	named-checkconf takes '-t directory' similar to named. [RT #726]

(continues on next page)

(continued from previous page)

- 712. [bug] Sending a large signed update message caused an assertion failure. [RT #718]
- 711. [bug] The libisc and liblwres implementations of inet\_ntop contained an off by one error.
- 710. [func] The forwarders statement now takes an optional port. [RT #418]
- 709. [bug] ANY or SIG queries for data with a TTL of 0 would return SERVFAIL. [RT #620]
- 708. [bug] When building with --with-openssl, the openssl headers included with BIND 9 should not be used. [RT #702]
- 707. [func] The "filename" argument to named-checkzone is no longer optional, to reduce confusion. [RT #612]
- 706. [bug] Zones with an explicit "allow-update { none; };" were considered dynamic and therefore not reloaded on SIGHUP or "rndc reload".
- 705. [port] Work out resource limit type for use where rlim\_t is not available. [RT #695]
- 704. [port] RLIMIT\_NOFILE is not available on all platforms. [RT #695]
- 703. [port] sys/select.h is needed on older platforms. [RT #695]
- 702. [func] If the address 0.0.0.0 is seen in resolv.conf, use 127.0.0.1 instead. [RT #693]
- 701. [func] Root hints are now fully optional. Class IN views use compiled-in hints by default, as before. Non-IN views with no root hints now provide authoritative service but not recursion. A warning is logged if a view has neither root hints nor authoritative data for the root. [RT #696]
- 700. [bug] \$GENERATE range check was wrong. [RT #688]
- 699. [bug] The lexer mishandled empty quoted strings. [RT #694]
- 698. [bug] Aborting nsupdate with ^C would lead to several race conditions.
- 697. [bug] nsupdate was not compatible with the undocumented BIND 8 behavior of ignoring TTLs in "update delete" commands. [RT #693]

(continues on next page)

(continued from previous page)

- 696. [bug] lwresd would die with an assertion failure when passed a zero-length name. [RT #692]
- 695. [bug] If the resolver attempted to query a blackholed or bogus server, the resolution would fail immediately.
- 694. [bug] \$GENERATE did not produce the last entry. [RT #682, #683]
- 693. [bug] An empty lwres statement in named.conf caused the server to crash while loading.
- 692. [bug] Deal with systems that have getaddrinfo() but not gai\_strerror(). [RT #679]
- 691. [bug] Configuring per-view forwarders caused an assertion failure. [RT #675, #734]
- 690. [func] \$GENERATE now supports DNAME. [RT #654]
- 689. [doc] man pages are now installed. [RT #210]
- 688. [func] "make tags" now works on systems with the "Exuberant Ctags" etags.
- 687. [bug] Only say we have IPv6, with sufficient functionality, if it has actually been tested. [RT #586]
- 686. [bug] dig and nslookup can now be properly aborted during blocking operations. [RT #568]
- 685. [bug] nslookup should use the search list/domain options from resolv.conf by default. [RT #405, #630]
- 684. [bug] Memory leak with view forwarders. [RT #656]
- 683. [bug] File descriptor leak in isc\_lex\_openfile().
- 682. [bug] nslookup displayed SOA records incorrectly. [RT #665]
- 681. [bug] \$GENERATE specifying output format was broken. [RT #653]
- 680. [bug] dns\_rdata\_fromstruct() mishandled options bigger than 255 octets.
- 679. [bug] \$INCLUDE could leak memory and file descriptors on reload. [RT #639]
- 678. [bug] "transfer-format one-answer;" could trigger an assertion failure. [RT #646]
- 677. [bug] dnssec-signzone would occasionally use the wrong ttl

(continues on next page)

(continued from previous page)

		for database operations and fail. [RT #643]
676.	[bug]	Log messages about lame servers to category 'lame-servers' rather than 'resolver', so as not to be gratuitously incompatible with BIND 8.
675.	[bug]	TKEY queries could cause the server to leak memory.
674.	[func]	Allow messages to be TSIG signed / verified using a offset from the current time.
673.	[func]	The server can now convert RFC1886-style recursive lookup requests into RFC2874-style lookups, when enabled using the new option "allow-v6-synthesis".
672.	[bug]	The wrong time was in the "time signed" field when replying with BADTIME error.
671.	[bug]	The message code was failing to parse a message with no question section and a TSIG record. [RT #628]
670.	[bug]	The lwres replacements for getaddrinfo and getipnodebyname didn't properly check for the existence of the sockaddr sa_len field.
669.	[bug]	dnssec-keygen now makes the public key file non-world-readable for symmetric keys. [RT #403]
668.	[func]	named-checkzone now reports multiple errors in master files.
667.	[bug]	On Linux, running named with the -u option and a non-world-readable configuration file didn't work. [RT #626]
666.	[bug]	If a request sent by dig is longer than 512 bytes, use TCP.
665.	[bug]	Signed responses were not sent when the size of the TSIG + question exceeded the maximum message size. [RT #628]
664.	[bug]	The t_tasks and t_timers module tests are now skipped when building without threads, since they require threads.
663.	[func]	Accept a size_spec, not just an integer, in the (unimplemented and ignored) max-ixfr-log-size option for compatibility with recent versions of BIND 8. [RT #613]

(continues on next page)

(continued from previous page)

- 662. [bug] dns\_rdata\_fromtext() failed to log certain errors.
- 661. [bug] Certain UDP IXFR requests caused an assertion failure (mpctx->allocated == 0). [RT #355, #394, #623]
- 660. [port] Detect multiple CPUs on HP-UX and IRIX.
- 659. [performance] Rewrite the name compression code to be much faster.
- 658. [cleanup] Remove all vestiges of 16 bit global compression.
- 657. [bug] When a listen-on statement in an lwres block does not specify a port, use 921, not 53. Also update the listen-on documentation. [RT #616]
- 656. [func] Treat an unescaped newline in a quoted string as an error. This means that TXT records with missing close quotes should have meaningful errors printed.
- 655. [bug] Improve error reporting on unexpected eof when loading zones. [RT #611]
- 654. [bug] Origin was being forgotten in TCP retries in dig. [RT #574]
- 653. [bug] +defname option in dig was reversed in sense. [RT #549]
- 652. [bug] zone\_saveunique() did not report the new name.
- 651. [func] The AD bit in responses now has the meaning specified in <draft-ietf-dnsext-ad-is-secure>.
- 650. [bug] SIG(0) records were being generated and verified incorrectly. [RT #606]
- 649. [bug] It was possible to join to an already running fctx after it had "cloned" its events, but before it sent them. In this case, the event of the newly joined fetch would not contain the answer, and would trigger the INSIST() in fctx\_sendevents(). In BIND 9.0, this bug did not trigger an INSIST(), but caused the fetch to fail with a SERVFAIL result. [RT #588, #597, #605, #607]
- 648. [port] Add support for pre-RFC2133 IPv6 implementations.
- 647. [bug] Resolver queries sent after following multiple referrals had excessively long retransmission timeouts due to incorrectly counting the referrals as "restarts".

(continues on next page)

(continued from previous page)

- 646. [bug] The UnixWare ISC\_PLATFORM\_FIXIN6INADDR fix in isc/net.h didn't `_cleanly_` fix the problem it was trying to fix.
- 645. [port] BSD/OS 3.0 needs `pthread_init()`. [RT #603]
- 644. [bug] #622 needed more work. [RT #562]
- 643. [bug] `xfrin` error messages made more verbose, added class of the zone. [RT #599]
- 642. [bug] Break the `exit_check()` race in the zone module. [RT #598]

- 9.1.0b2 released ---
- 641. [bug] `$GENERATE` caused a uninitialized link to be used. [RT #595]
  - 640. [bug] Memory leak in error path could cause "`mpctx->allocated == 0`" failure. [RT #584]
  - 639. [bug] Reading entropy from the keyboard would sometimes fail. [RT #591]
  - 638. [port] `lib/isc/random.c` needed to explicitly include `time.h` to get a prototype for `time()` when `pthread`s was not being used. [RT #592]
  - 637. [port] Use `isc_u?int64_t` instead of (unsigned) long long in `lib/isc/print.c`. Also allow `lib/isc/print.c` to be compiled even if the platform does not need it. [RT #592]
  - 636. [port] Shut up `MSVC++` about a possible loss of precision in the `ISC__BUFFER_PUTUINT*()` macros. [RT #592]
  - 635. [bug] Reloading a server with a configured blackhole list would cause an assertion. [RT #590]
  - 634. [bug] A log file will completely stop being written when it reaches the maximum size in all cases, not just when versioning is also enabled. [RT #570]
  - 633. [port] Cope with `rlim_t` missing on BSD/OS systems. [RT #575]
  - 632. [bug] The index array of the journal file was corrupted as it was written to disk.
  - 631. [port] Build without thread support on systems without `pthread`s.
  - 630. [bug] Locking failure in zone code. [RT #582]

(continues on next page)

(continued from previous page)

629. [bug] 9.1.0b1 dereferenced a null pointer and crashed when responding to a UDP IXFR request.
628. [bug] If the root hints contained only AAAA addresses, named would be unable to perform resolution.
627. [bug] The EDNS0 blackhole detection code of change 324 waited for three retransmissions to each server, which takes much too long when a domain has many name servers and all of them drop EDNS0 queries. Now we retry without EDNS0 after three consecutive timeouts, even if they are all from different servers. [RT #143]
626. [bug] The lightweight resolver daemon no longer crashes when asked for a SIG rrset. [RT #558]
625. [func] Zones now inherit their class from the enclosing view.
624. [bug] The zone object could get timer events after it had been destroyed, causing a server crash. [RT #571]
623. [func] Added "named-checkconf" and "named-checkzone" program for syntax checking named.conf files and zone files, respectively.
622. [bug] A canceled request could be destroyed before dns\_request\_destroy() was called. [RT #562]
621. [port] Disable IPv6 at runtime if IPv6 sockets are unusable. This mostly affects Red Hat Linux 7.0, which has conflicts between libc and the kernel.
620. [bug] dns\_master\_load\*inc() now require 'task' and 'load' to be non-null. Also 'done' will not be called if dns\_master\_load\*inc() fails immediately. [RT #565]
619. [placeholder]
618. [bug] Queries to a signed zone could sometimes cause an assertion failure.
617. [bug] When using dynamic update to add a new RR to an existing RRset with a different TTL, the journal entries generated from the update did not include explicit deletions and re-additions of the existing RRs to update their TTL to the new value.
616. [func] dnssec-signzone -t output now includes performance statistics.

(continues on next page)

(continued from previous page)

615.	[bug]	dnssec-signzone did not like child keysets signed by multiple keys.
614.	[bug]	Checks for uninitialized link fields were prone to false positives, causing assertion failures. The checks are now disabled by default and may be re-enabled by defining ISC_LIST_CHECKINIT.
613.	[bug]	"rndc reload zone" now reloads primary zones. It previously only updated slave and stub zones, if an SOA query indicated an out of date serial.
612.	[cleanup]	Shutup a ridiculously noisy HP-UX compiler that complains relentlessly about how its treatment of 'const' has changed as well as how casting sometimes tightens alignment constraints.
611.	[func]	allow-notify can be used to permit processing of notify messages from hosts other than a slave's masters.
610.	[func]	rndc dumpdb is now supported.
609.	[bug]	getrrsetbyname() would crash lwresd if the server found more SIGs than answers. [RT #554]
608.	[func]	dnssec-signzone now adds a comment to the zone with the time the file was signed.
607.	[bug]	nsupdate would fail if it encountered a CNAME or DNAME in a response to an SOA query. [RT #515]
606.	[bug]	Compiling with --disable-threads failed due to isc_thread_self() being incorrectly defined as an integer rather than a function.
605.	[func]	New function isc_lex_getlasttokentext().
604.	[bug]	The named.conf parser could print incorrect line numbers when long comments were present.
603.	[bug]	Make dig handle multiple types or classes on the same query more correctly.
602.	[func]	Cope automatically with UnixWare's broken IN6_IS_ADDR_* macros. [RT #539]
601.	[func]	Return a non-zero exit code if an update fails in nsupdate.
600.	[bug]	Reverse lookups sometimes failed in dig, etc...

(continues on next page)

(continued from previous page)

599.	[func]	Added four new functions to the libisc log API to support i18n messages. <code>isc_log_iwrite()</code> , <code>isc_log_ivwrite()</code> , <code>isc_log_iwrite1()</code> and <code>isc_log_ivwrite1()</code> were added.
598.	[bug]	An update-policy statement would cause the server to assert while loading. [RT #536]
597.	[func]	<code>dnssec-signzone</code> is now multi-threaded.
596.	[bug]	<code>DNS_RDATASLAB_FORCE</code> and <code>DNS_RDATASLAB_EXACT</code> are not mutually exclusive.
595.	[port]	On Linux 2.2, <code>socket()</code> returns <code>EINVAL</code> when it should return <code>EAFNOSUPPORT</code> . Work around this. [RT #531]
594.	[func]	<code>sdb</code> drivers are now assumed to not be thread-safe unless the <code>DNS_SDBFLAG_THREADSAFE</code> flag is supplied.
593.	[bug]	If a secure zone was missing all its NXTs and a dynamic update was attempted, the server entered an infinite loop.
592.	[bug]	The <code>sig-validity-interval</code> option now specifies a number of days, not seconds. This matches the documentation. [RT #529]

--- 9.1.0b1 released ---

591.	[bug]	Work around non-reentrancy in <code>openssl</code> by disabling pre-computation in keys.
590.	[doc]	There are now man pages for the <code>lwres</code> library in <code>doc/man/lwres</code> .
589.	[bug]	The server could deadlock if a zone was updated while being transferred out.
588.	[bug]	<code>ctx-&gt;in_use</code> was not being correctly initialized when pushing a file for <code>\$INCLUDE</code> . [RT #523]
587.	[func]	A warning is now printed if the "allow-update" option allows updates based on the source IP address, to alert users to the fact that this is insecure and becoming increasingly so as servers capable of update forwarding are being deployed.
586.	[bug]	multiple views with the same name were fatal. [RT #516]
585.	[func]	<code>dns_db_addrdataset()</code> and <code>dns_rdataslab_merge()</code>

(continues on next page)

(continued from previous page)

		now support 'exact' additions in a similar manner to <code>dns_db_subtractrdataset()</code> and <code>dns_rdataslab_subtract()</code> .
584.	[func]	You can now say 'notify explicit'; to suppress notification of the servers listed in NS records and notify only those servers listed in the 'also-notify' option.
583.	[func]	"rndc querylog" will now toggle logging of queries, like "ndc querylog" in BIND 8.
582.	[bug]	<code>dns_zone_idetach()</code> failed to lock the zone. [RT #199, #463]
581.	[bug]	log severity was not being correctly processed. [RT #485]
580.	[func]	Ignore trailing garbage on incoming DNS packets, for interoperability with broken server implementations. [RT #491]
579.	[bug]	<code>nsupdate</code> did not take a filename to read update from. [RT #492]
578.	[func]	New config option "notify-source", to specify the source address for notify messages.
577.	[func]	Log illegal RDATA combinations. e.g. multiple singleton types, cname and other data.
576.	[doc]	<code>isc_log_create()</code> description did not match reality.
575.	[bug]	<code>isc_log_create()</code> was not setting internal state correctly to reflect the default channels created.
574.	[bug]	TSIG signed queries sent by the resolver would fail to have their responses validated and would leak memory.
573.	[bug]	The journal files of IXFR slave zones were inadvertently discarded on server reload, causing "journal out of sync with zone" errors on subsequent reloads. [RT #482]
572.	[bug]	Quoted strings were not accepted as key names in address match lists.
571.	[bug]	It was possible to create an <code>rdataset</code> of singleton type which had more than one <code>rdata</code> . [RT #154] [RT #279]
570.	[bug]	<code>rbtdb.c</code> allowed zones containing nodes which had both a CNAME and "other data". [RT #154]

(continues on next page)

(continued from previous page)

- 569. [func] The DNSSEC AD bit will not be set on queries which have not requested a DNSSEC response.
- 568. [func] Add sample simple database drivers in contrib/sdb.
- 567. [bug] Setting the zone transfer timeout to zero caused an assertion failure. [RT #302]
- 566. [func] New public function `dns_timer_setidle()`.
- 565. [func] Log queries more like BIND 8: query logging is now done to category "queries", level "info". [RT #169]
- 564. [func] Add sortlist support to lwresd.
- 563. [func] New public functions `dns_rdatatype_format()` and `dns_rdataclass_format()`, for convenient formatting of rdata type/class mnemonics in log messages.
- 562. [cleanup] Moved `lib/dns/*conf.c` to `bin/named` where they belong.
- 561. [func] The 'datasize', 'stacksize', 'coresize' and 'files' clauses of the `options{}` statement are now implemented.
- 560. [bug] `dns_name_split` did not properly the resulting prefix when a maximal length bitstring label was split which was preceded by another bitstring label. [RT #429]
- 559. [bug] `dns_name_split` did not properly create the suffix when splitting within a maximal length bitstring label.
- 558. [func] New functions, `isc_resource_getlimit` and `isc_resource_setlimit`.
- 557. [func] Symbolic constants for libisc integral types.
- 556. [func] The DNSSEC OK bit in the EDNS extended flags is now implemented. Responses to queries without this bit set will not contain any DNSSEC records.
- 555. [bug] A slave server attempting a zone transfer could crash with an assertion failure on certain malformed responses from the master. [RT #457]
- 554. [bug] In some cases, not all of the dnssec tools were properly installed.
- 553. [bug] Incoming zone transfers deferred due to quota were not started when quota was increased but only when a transfer in progress finished. [RT #456]

(continues on next page)

(continued from previous page)

552.	[bug]	We were not correctly detecting the end of all c-style comments. [RT #455]
551.	[func]	Implemented the 'sortlist' option.
550.	[func]	Support unknown rdata types and classes.
549.	[bug]	"make" did not immediately abort the build when a subdirectory make failed [RT #450].
548.	[func]	The lexer now ungets tokens more correctly.
547.	[placeholder]	
546.	[func]	Option 'lame-ttl' is now implemented.
545.	[func]	Name limit and counting options removed from dig; they didn't work properly, and cannot be correctly implemented without significant changes.
544.	[func]	Add statistics option, enable statistics-file option, add RNDC option "dump-statistics" to write out a query statistics file.
543.	[doc]	The 'port' option is now documented.
542.	[func]	Add support for update forwarding as required for full compliance with RFC2136. It is turned off by default and can be enabled using the 'allow-update-forwarding' option.
541.	[func]	Add bogus server support.
540.	[func]	Add dialup support.
539.	[func]	Support the blackhole option.
538.	[bug]	fix buffer overruns by 1 in lwres_getnameinfo().
537.	[placeholder]	
536.	[func]	Use transfer-source{-v6} when sending refresh queries. Transfer-source{-v6} now take a optional port parameter for setting the UDP source port. The port parameter is ignored for TCP.
535.	[func]	Use transfer-source{-v6} when forwarding update requests.
534.	[func]	Ancestors have been removed from RBT chains. Ancestor information can be discerned via node parent pointers.

(continues on next page)

(continued from previous page)

- 533. [func] Incorporated name hashing into the RBT database to improve search speed.
- 532. [func] Implement DNS UPDATE pseudo records using DNS\_RDATA\_UPDATE flag.
- 531. [func] Rdata really should be initialized before being assigned to (dns\_rdata\_fromwire(), dns\_rdata\_fromtext(), dns\_rdata\_clone(), dns\_rdata\_fromregion()), check that it is.
- 530. [func] New function dns\_rdata\_invalidate().
- 529. [bug] 521 contained a bug which caused zones to always reload. [RT #410]
- 528. [func] The ISC\_LIST\_XXXX macros now perform sanity checks on their arguments. ISC\_LIST\_XXXXUNSAFE can be use to skip the checks however use with caution.
- 527. [func] New function dns\_rdata\_clone().
- 526. [bug] nsupdate incorrectly refused to add RRs with a TTL of 0.
- 525. [func] New arguments 'options' for dns\_db\_subtractrdataset(), and 'flags' for dns\_rdataslab\_subtract() allowing you to request that the RR's must exist prior to deletion. DNS\_R\_NOTEXACT is returned if the condition is not met.
- 524. [func] The 'forward' and 'forwarders' statement in non-forward zones should work now.
- 523. [doc] The source to the Administrator Reference Manual is now an XML file using the DocBook DTD, and is included in the distribution. The plain text version of the ARM is temporarily unavailable while we figure out how to generate readable plain text from the XML.
- 522. [func] The lightweight resolver daemon can now use a real configuration file, and its functionality can be provided by a name server. Also, the -p and -P options to lwresd have been reversed.
- 521. [bug] Detect master files which contain \$INCLUDE and always reload. [RT #196]
- 520. [bug] Upgraded libtool to 1.3.5, which makes shared library builds almost work on AIX (and possibly others).
- 519. [bug] dns\_name\_split() would improperly split some bitstring

(continues on next page)

(continued from previous page)

- labels, zeroing a few of the least significant bits in the prefix part. When such an improperly created prefix was returned to the RBT database, the bogus label was dutifully stored, corrupting the tree. [RT #369]
- 518. [bug] The resolver did not realize that a DNAME which was "the answer" to the client's query was "the answer", and such queries would fail. [RT #399]
- 517. [bug] The resolver's DNAME code would trigger an assertion if there was more than one DNAME in the chain. [RT #399]
- 516. [bug] Cache lookups which had a NULL node pointer, e.g. those by `dns_view_find()`, and which would match a DNAME, would trigger an `INSIST(!search.need_cleanup)` assertion. [RT #399]
- 515. [bug] The `ssu` table was not being attached / detached by `dns_zone_[sg]etssutable`. [RT #397]
- 514. [func] Retry refresh and notify queries if they timeout. [RT #388]
- 513. [func] New functionality added to `rdnc` and `server` to allow individual zones to be refreshed or reloaded.
- 512. [bug] The zone transfer code could throw an exception with an invalid IXFR stream.
- 511. [bug] The message code could throw an assertion on an out of memory failure. [RT #392]
- 510. [bug] Remove spurious view notify warning. [RT #376]
- 509. [func] Add support for write of zone files on shutdown.
- 508. [func] `dns_message_parse()` can now do a best-effort attempt, which should allow `dig` to print more invalid messages.
- 507. [func] New functions `dns_zone_flush()`, `dns_zt_flushanddetach()` and `dns_view_flushanddetach()`.
- 506. [func] Do not fail to start on errors in zone files.
- 505. [bug] `nsupdate` was printing "unknown result code". [RT #373]
- 504. [bug] The zone was not being marked as dirty when updated via IXFR.

(continues on next page)

(continued from previous page)

- 503. [bug] dumptime was not being set along with DNS\_ZONEFLG\_NEEDDUMP.
- 502. [func] On a SERVFAIL reply, DiG will now try the next server in the list, unless the +fail option is specified.
- 501. [bug] Incorrect port numbers were being displayed by nslookup. [RT #352]
- 500. [func] Nearly useless +details option removed from DiG.
- 499. [func] In DiG, specifying a class with -c or type with -t changes command-line parsing so that classes and types are only recognized if following -c or -t. This allows hosts with the same name as a class or type to be looked up.
- 498. [doc] There is now a man page for "dig" in doc/man/bin/dig.1.
- 497. [bug] The error messages printed when an IP match list contained a network address with a nonzero host part were not sufficiently detailed. [RT #365]
- 496. [bug] named didn't sanity check numeric parameters. [RT #361]
- 495. [bug] nsupdate was unable to handle large records. [RT #368]
- 494. [func] Do not cache NXDOMAIN responses for SOA queries.
- 493. [func] Return non-cachable (ttl = 0) NXDOMAIN responses for SOA queries. This makes it easier to locate the containing zone without polluting intermediate caches.
- 492. [bug] attempting to reload a zone caused the server fail to shutdown cleanly. [RT #360]
- 491. [bug] nsupdate would segfault when sending certain prerequisites with empty RDATA. [RT #356]
- 490. [func] When a slave/stub zone has not yet successfully obtained an SOA containing the zone's configured retry time, perform the SOA query retries using exponential backoff. [RT #337]
- 489. [func] The zone manager now has a "i/o" queue.
- 488. [bug] Locks weren't properly destroyed in some cases.
- 487. [port] flockfile() is not defined on all systems.

(continues on next page)

(continued from previous page)

- 486. [bug] nslookup: "set all" and "server" commands showed the incorrect port number if a port other than 53 was specified. [RT #352]
- 485. [func] When dig had more than one server to query, it would send all of the messages at the same time. Add rate limiting of the transmitted messages.
- 484. [bug] When the server was reloaded after removing addresses from the named.conf "listen-on" statement, sockets were still listening on the removed addresses due to reference count loops. [RT #325]
- 483. [bug] nslookup: "set all" showed a "search" option but it was not settable.
- 482. [bug] nslookup: a plain "server" or "lserver" should be treated as a lookup.
- 481. [bug] nslookup:get\_next\_command() stack size could exceed per thread limit.
- 480. [bug] strtok() is not thread safe. [RT #349]
- 479. [func] The test suite can now be run by typing "make check" or "make test" at the top level.
- 478. [bug] "make install" failed if the directory specified with --prefix did not already exist.
- 477. [bug] The the isc-config.sh script could be installed before its directory was created. [RT #324]
- 476. [bug] A zone could expire while a zone transfer was in progress triggering a INSIST failure. [RT #329]
- 475. [bug] query\_getzonedb() sometimes returned a non-null version on failure. This caused assertion failures when generating query responses where names subject to additional section processing pointed to a zone to which access had been denied by means of the allow-query option. [RT #336]
- 474. [bug] The mnemonic of the CHAOS class is CH according to RFC1035, but it was printed and read only as CHAOS. We now accept both forms as input, and print it as CH. [RT #305]
- 473. [bug] nsupdate overran the end of the list of name servers when no servers could be reached, typically causing it to print the error message "dns\_request\_create: not implemented".

(continues on next page)

(continued from previous page)

- 472. [bug] Off-by-one error caused `isc_time_add()` to sometimes produce invalid time values.
- 471. [bug] `nsupdate` didn't compile on HP/UX 10.20
- 470. [func] `$GENERATE` is now supported. See also `doc/misc/migration`.
- 469. [bug] `"query-source address * port 53;"` now works.
- 468. [bug] `dns_master_load*()` failed to report file and line number in certain error conditions.
- 467. [bug] `dns_master_load*()` failed to log an error if `pushfile()` failed.
- 466. [bug] `dns_master_load*()` could return success when it failed.
- 465. [cleanup] Allow 0 to be set as an `omapi_value_t` value by `omapi_value_storeint()`.
- 464. [cleanup] Build with `openssl`'s RSA code instead of `dnssafe`.
- 463. [bug] `nsupdate` sent malformed SOA queries to the second and subsequent name servers in `resolv.conf` if the query sent to the first one failed.
- 462. [bug] `--disable-ipv6` should work now.
- 461. [bug] Specifying an unknown key in the "keys" clause of the "controls" statement caused a NULL pointer dereference. [RT #316]
- 460. [bug] Much of the DNSSEC code only worked with class IN.
- 459. [bug] `Nslookup` processed the "set" command incorrectly.
- 458. [bug] `Nslookup` didn't properly check class and type values. [RT #305]
- 457. [bug] `Dig/host/hslookup` didn't properly handle connect timeouts in certain situations, causing an unnecessary warning message to be printed.
- 456. [bug] Stub zones were not resetting the refresh and expire counters, `loadtime` or clearing the `DNS_ZONE_REFRESH` (refresh in progress) flag upon successful update. This disabled further refreshing of the stub zone, causing it to eventually expire. [RT #300]
- 455. [doc] Document IPv4 prefix notation does not require a

(continues on next page)

(continued from previous page)

		dotted decimal quad but may be just dotted decimal.
454.	[bug]	Enforce dotted decimal and dotted decimal quad where documented as such in named.conf. [RT #304, RT #311]
453.	[bug]	Warn if the obsolete option "maintain-ixfr-base" is specified in named.conf. [RT #306]
452.	[bug]	Warn if the unimplemented option "statistics-file" is specified in named.conf. [RT #301]
451.	[func]	Update forwarding implemented.
450.	[func]	New function ns_client_senddraw().
449.	[bug]	isc_bitstring_copy() only works correctly if the two bitstrings have the same lsb0 value, but this requirement was not documented, nor was there a REQUIRE for it.
448.	[bug]	Host output formatting change, to match v8. [RT #255]
447.	[bug]	Dig didn't properly retry in TCP mode after a truncated reply. [RT #277]
446.	[bug]	Confusing notify log message. [RT #298]
445.	[bug]	Doing a 0 bit isc_bitstring_copy() of an lsb0 bitstring triggered a REQUIRE statement. The REQUIRE statement was incorrect. [RT #297]
444.	[func]	"recursion denied" messages are always logged at debug level 1, now, rather than sometimes at ERROR. This silences these warnings in the usual case, where some clients set the RD bit in all queries.
443.	[bug]	When loading a master file failed because of an unrecognized RR type name, the error message did not include the file name and line number. [RT #285]
442.	[bug]	TSIG signed messages that did not match any view crashed the server. [RT #290]
441.	[bug]	Nodes obscured by a DNAME were inaccessible even when DNS_DBFIND_GLUEOK was set.
440.	[func]	New function dns_zone_forwardupdate().
439.	[func]	New function dns_request_createraw().
438.	[func]	New function dns_message_getrawmessage().

(continues on next page)

(continued from previous page)

- 437. [func] Log NOTIFY activity to the notify channel.
- 436. [bug] If recvmsg() returned EHOSTUNREACH or ENETUNREACH, which sometimes happens on Linux, named would enter a busy loop. Also, unexpected socket errors were not logged at a high enough logging level to be useful in diagnosing this situation. [RT #275]
- 435. [bug] dns\_zone\_dump() overwrote existing zone files rather than writing to a temporary file and renaming. This could lead to empty or partial zone files being left around in certain error conditions involving the initial transfer of a slave zone, interfering with subsequent server startup. [RT #282]
- 434. [func] New function isc\_file\_isabsolute().
- 433. [func] isc\_base64\_decodestring() now accepts newlines within the base64 data. This makes it possible to break up the key data in a "trusted-keys" statement into multiple lines. [RT #284]
- 432. [func] Added refresh/retry jitter. The actual refresh/retry time is now a random value between 75% and 100% of the configured value.
- 431. [func] Log at ISC\_LOG\_INFO when a zone is successfully loaded.
- 430. [bug] Rewrote the lightweight resolver client management code to handle shutdown correctly and general cleanup.
- 429. [bug] The space reserved for a TSIG record in a response was 2 bytes too short, leading to message generation failures.
- 428. [bug] rbtodb.c:find\_closest\_nxt() erroneously returned DNS\_R\_BADDB for nodes which had neither NXT nor SIG NXT (e.g. glue). This could cause SERVFAILs when generating negative responses in a secure zone.
- 427. [bug] Avoid going into an infinite loop when the validator gets a negative response to a key query where the records are signed by the missing key.
- 426. [bug] Attempting to generate an oversized RSA key could cause dnssec-keygen to dump core.
- 425. [bug] Warn about the auth-nxdomain default value change

(continues on next page)

(continued from previous page)

		if there is no auth-nxdomain statement in the config file. [RT #287]
424.	[bug]	notify_createmessage() could trigger an assertion failure when creating the notify message failed, e.g. due to corrupt zones with multiple SOA records. [RT #279]
423.	[bug]	When responding to a recursive query, errors that occur after following a CNAME should cause the query to fail. [RT #274]
422.	[func]	get rid of isc_random_t, and make isc_random_get() and isc_random_jitter() use rand() internally instead of local state. Note that isc_random_*() functions are only for weak, non-critical "randomness" such as timing jitter and such.
421.	[bug]	nslookup would exit when given a blank line as input.
420.	[bug]	nslookup failed to implement the "exit" command.
419.	[bug]	The certificate type PKIX was misspelled as SKIX.
418.	[bug]	At debug levels >= 10, getting an unexpected socket receive error would crash the server while trying to log the error message.
417.	[func]	Add isc_app_block() and isc_app_unblock(), which allow an application to handle signals while blocking.
416.	[bug]	Slave zones with no master file tried to use a NULL pointer for a journal file name when they received an IXFR. [RT #273]
415.	[bug]	The logging code leaked file descriptors.
414.	[bug]	Server did not shut down until all incoming zone transfers were finished.
413.	[bug]	Notify could attempt to use the zone database after it had been unloaded. [RT #267]
412.	[bug]	named -v didn't print the version.
411.	[bug]	A typo in the HS A code caused an assertion failure.
410.	[bug]	lwres_gethostbyname() and company set lwres_h_errno to a random value on success.
409.	[bug]	If named was shut down early in the startup

(continues on next page)

(continued from previous page)

		process, ns_omapi_shutdown() would attempt to lock an uninitialized mutex. [RT #262]
408.	[bug]	stub zones could leak memory and reference counts if all the masters were unreachable.
407.	[bug]	isc_rwlock_lock() would needlessly block readers when it reached the read quota even if no writers were waiting.
406.	[bug]	Log messages were occasionally lost or corrupted due to a race condition in isc_log_doit().
405.	[func]	Add support for selective forwarding (forward zones)
404.	[bug]	The request library didn't completely work with IPv6.
403.	[bug]	"host" did not use the search list.
402.	[bug]	Treat undefined acls as errors, rather than warning and then later throwing an assertion. [RT #252]
401.	[func]	Added simple database API.
400.	[bug]	SIG(0) signing and verifying was done incorrectly. [RT #249]

399.	[bug]	When reloading the server with a config file containing a syntax error, it could catch an assertion failure trying to perform zone maintenance on, or sending notifies from, tentatively created zones whose views were never fully configured and lacked an address database and request manager.
398.	[bug]	"dig" sometimes caught an assertion failure when using TSIG, depending on the key length.
397.	[func]	Added utility functions dns_view_gettsig() and dns_view_getpeertsig().
396.	[doc]	There is now a man page for "nsupdate" in doc/man/bin/nsupdate.8.
395.	[bug]	nslookup printed incorrect RR type mnemonics for RRs of type >= 21 [RT #237].
394.	[bug]	Current name was not propagated via \$INCLUDE.
393.	[func]	Initial answer while loading (awl) support. Entry points: dns_master_loadfileinc(),

(continues on next page)

(continued from previous page)

		dns_master_loadstreaminc(), dns_master_loadbufferinc(). Note: calls to dns_master_load*inc() should be rate be rate limited so as to not use up all file descriptors.
392.	[func]	Add ISC_R_FAMILYNOSUPPORT. Returned when OS does not support the given address family requested.
391.	[clarity]	ISC_R_FAMILY -> ISC_R_FAMILYMISMATCH.
390.	[func]	The function dns_zone_setdbtype() now takes an argc/argv style vector of words and sets both the zone database type and its arguments, making the functions dns_zone_adddbarg() and dns_zone_cleardbargs() unnecessary.
389.	[bug]	Attempting to send a request over IPv6 using dns_request_create() on a system without IPv6 support caused an assertion failure [RT #235].
388.	[func]	dig and host can now do reverse ipv6 lookups.
387.	[func]	Add dns_byaddr_createptrname(), which converts an address into the name used by a PTR query.
386.	[bug]	Missing strdup() of ACL name caused random ACL matching failures [RT #228].
385.	[cleanup]	Removed functions dns_zone_equal(), dns_zone_print(), and dns_zt_print().
384.	[bug]	nsupdate was incorrectly limiting TTLs to 65535 instead of 2147483647.
383.	[func]	When writing a master file, print the SOA and NS records (and their SIGs) before other records.
382.	[bug]	named -u failed on many Linux systems where the libc provided kernel headers do not match the current kernel.
381.	[bug]	Check for IPV6_RECVPKTINFO and use it instead of IPV6_PKTINFO if found. [RT #229]
380.	[bug]	nsupdate didn't work with IPv6.
379.	[func]	New library function isc_sockaddr_anyofpf().
378.	[func]	named and lwresd will log the command line arguments they were started with in the "starting ..." message.
377.	[bug]	When additional data lookups were refused due to

(continues on next page)

(continued from previous page)

		"allow-query", the databases were still being attached causing reference leaks.
376.	[bug]	The server should always use good entropy when performing cryptographic functions needing entropy.
375.	[bug]	Per-zone "allow-query" did not properly override the view/global one for CNAME targets and additional data [RT #220].
374.	[bug]	SOA in authoritative negative responses had wrong TTL.
373.	[func]	nslookup is now installed by "make install".
372.	[bug]	Deal with Microsoft DNS servers appending two bytes of garbage to zone transfer requests.
371.	[bug]	At high debug levels, doing an outgoing zone transfer of a very large RRset could cause an assertion failure during logging.
370.	[bug]	The error messages for roll-forward failures were overly terse.
369.	[func]	Support new named.conf options, view and zone statements:  <div style="margin-left: 40px;">                     max-retry-time, min-retry-time,                      max-refresh-time, min-refresh-time.                 </div>
368.	[func]	Restructure the internal ".bind" view so that more zones can be added to it.
367.	[bug]	Allow proper selection of server on nslookup command line.
366.	[func]	Allow use of '-' batch file in dig for stdin.
365.	[bug]	nsupdate -k leaked memory.
364.	[func]	Added additional-from-{cache,auth}
363.	[placeholder]	
362.	[bug]	rndc no longer aborts if the configuration file is missing an options statement. [RT #209]
361.	[func]	When the RBT find or chain functions set the name and origin for a node that stores the root label the name is now set to an empty name, instead of ".", to simplify later use of the name and origin by dns_name_concatenate(), dns_name_totext() or

(continues on next page)

(continued from previous page)

		<code>dns_name_format()</code> .
360.	[func]	<code>dns_name_totext()</code> and <code>dns_name_format()</code> now allow an empty name to be passed, which is formatted as "@".
359.	[bug]	<code>dnssec-signzone</code> occasionally signed glue records.
358.	[cleanup]	Rename the intermediate files used by the <code>dnssec</code> programs.
357.	[bug]	The zone file parser crashed if the argument to <code>\$INCLUDE</code> was a quoted string.
356.	[cleanup]	<code>isc_task_send</code> no longer requires <code>event-&gt;sender</code> to be non-null.
355.	[func]	Added <code>isc_dir_createunique()</code> , similar to <code>mkdtemp()</code> .
354.	[doc]	Man pages for the <code>dnssec</code> tools are now included in the distribution, in <code>doc/man/dnssec</code> .
353.	[bug]	double increment in <code>lwres/gethost.c:copytobuf()</code> . [RT #187]
352.	[bug]	Race condition in <code>dns_client_t</code> startup could cause an assertion failure.
351.	[bug]	Constructing a response with rcode <code>SERVFAIL</code> to a <code>TSIG</code> signed query could crash the server.
350.	[bug]	<code>Also-notify</code> lists specified in the global options block were not correctly reference counted, causing a memory leak.
349.	[bug]	Processing a query with the <code>CD</code> bit set now works as expected.
348.	[func]	New boolean <code>named.conf</code> options <code>'additional-from-auth'</code> and <code>'additional-from-cache'</code> now supported in view and global options statement.
347.	[bug]	Don't crash if an argument is left off options in <code>dig</code> .
346.	[placeholder]	
345.	[bug]	Large-scale changes/cleanups to <code>dig</code> : <ul style="list-style-type: none"> <li>* Significantly improve structure handling</li> <li>* Don't pre-load entire batch files</li> <li>* Add name/rr counting/limiting</li> <li>* Fix <code>SIGINT</code> handling</li> <li>* Shorten timeouts to match <code>v8</code>'s behavior</li> </ul>

(continues on next page)

(continued from previous page)

- 344. [bug] When shutting down, lwresd sometimes tried to shut down its client tasks twice, triggering an assertion.
- 343. [bug] Although zone maintenance SOA queries and notify requests were signed with TSIG keys when configured for the server in case, the TSIG was not verified on the response.
- 342. [bug] The wrong name was being passed to dns\_name\_dup() when generating a TSIG key using TKEY.
- 341. [func] Support 'key' clause in named.conf zone masters statement to allow authentication via TSIG keys:
 

```

masters {
    10.0.0.1 port 5353 key "foo";
    10.0.0.2 ;
};

```
- 340. [bug] The top-level COPYRIGHT file was missing from the distribution.
- 339. [bug] DNSSEC validation of the response to an ANY query at a name with a CNAME RR in a secure zone triggered an assertion failure.
- 338. [bug] lwresd logged to syslog as named, not lwresd.
- 337. [bug] "dig" did not recognize "nsap-ptr" as an RR type on the command line.
- 336. [bug] "dig -f" used 64 k of memory for each line in the file. It now uses much less, though still proportionally to the file size.
- 335. [bug] named would occasionally attempt recursion when it was disallowed or undesired.
- 334. [func] Added hmac-md5 to libisc.
- 333. [bug] The resolver incorrectly accepted referrals to domains that were not parents of the query name, causing assertion failures.
- 332. [func] New function dns\_name\_reset().
- 331. [bug] Only log "recursion denied" if RD is set. [RT #178]
- 330. [bug] Many debugging messages were partially formatted even when debugging was turned off, causing a

(continues on next page)

(continued from previous page)

- significant decrease in query performance.
- 329. [func] `omapi_auth_register()` now takes a `size_t` argument for the length of a key's secret data. Previously OMAPI only stored secrets up to the first NUL byte.
- 328. [func] Added `isc_base64_decodestring()`.
- 327. [bug] `rndc.conf` parser wasn't correctly recognizing an IP address where a host specification was required.
- 326. [func] 'keys' in an 'inet' control statement is now required and must have at least one item in it. A "not supported" warning is now issued if a 'unix' control channel is defined.
- 325. [bug] `isc_lex_gettoken` was processing octal strings when `ISC_LEXOPT_CNUMBER` was not set.
- 324. [func] In the resolver, turn EDNS0 off if there is no response after a number of retransmissions. This is to allow queries some chance of succeeding even if all the authoritative servers of a zone silently discard EDNS0 requests instead of sending an error response like they ought to.
- 323. [bug] `dns_rbt_findname()` did not ignore empty rbt nodes. Because of this, servers authoritative for a parent and grandchild zone but not authoritative for the intervening child zone did not correctly issue referrals to the servers of the child zone.
- 322. [bug] Queries for KEY RRs are now sent to the parent server before the authoritative one, making DNSSEC insecurity proofs work in many cases where they previously didn't.
- 321. [bug] When synthesizing a CNAME RR for a DNAME response, `query_addcname()` failed to initialize the type and class of the CNAME `dns_rdata_t`, causing random failures.
- 320. [func] Multiple `rndc` changes: parses an `rndc.conf` file, uses authentication to talk to `named`, command line syntax changed. This will all be described in the ARM.
- 319. [func] The `named.conf` "controls" statement is now used to configure the OMAPI command channel.
- 318. [func] `dns_c_ndcctx_destroy()` could never return anything except `ISC_R_SUCCESS`; made it have void return instead.

(continues on next page)

(continued from previous page)

- 317. [func] Use callbacks from libomapi to determine if a new connection is valid, and if a key requested to be used with that connection is valid.
- 316. [bug] Generate a warning if we detect an unexpected <eof> but treat as <eol><eof>.
- 315. [bug] Handle non-empty blanks lines. [RT #163]
- 314. [func] The named.conf controls statement can now have more than one key specified for the inet clause.
- 313. [bug] When parsing resolv.conf, don't terminate on an error. Instead, parse as much as possible, but still return an error if one was found.
- 312. [bug] Increase the number of allowed elements in the resolv.conf search path from 6 to 8. If there are more than this, ignore the remainder rather than returning a failure in lwres\_conf\_parse.
- 311. [bug] lwres\_conf\_parse failed when the first line of resolv.conf was empty or a comment.
- 310. [func] Changes to named.conf "controls" statement (inet subtype only)
  - support "keys" clause
 

```
controls {
    inet * port 1024
        allow { any; } keys { "foo"; }
}
```
  - allow "port xxx" to be left out of statement, in which case it defaults to omapi's default port of 953.
- 309. [bug] When sending a referral, the server did not look for name server addresses as glue in the zone holding the NS RRset in the case where this zone was not the same as the one where it looked for name server addresses as authoritative data.
- 308. [bug] Treat a SOA record not at top of zone as an error when loading a zone. [RT #154]
- 307. [bug] When canceling a query, the resolver didn't check for isc\_socket\_sendto() calls that did not yet have their completion events posted, so it could (rarely) end up destroying the query context and then want to use

(continues on next page)

(continued from previous page)

		it again when the send event posted, triggering an assertion as it tried to cancel an already-canceled query. [RT #77]
306.	[bug]	Reading HMAC-MD5 private key files didn't work.
305.	[bug]	When reloading the server with a config file containing a syntax error, it could catch an assertion failure trying to perform zone maintenance on tentatively created zones whose views were never fully configured and lacked an address database.
304.	[bug]	If more than LWRES_CONFMAXNAMESERVERS servers are listed in resolv.conf, silently ignore them instead of returning failure.
303.	[bug]	Add additional sanity checks to differentiate a AXFR response vs a IXFR response. [RT #157]
302.	[bug]	In dig, host, and nslookup, MXNAME should be large enough to hold any legal domain name in presentation format + terminating NULL.
301.	[bug]	Uninitialized pointer in host:printmessage(). [RT #159]
300.	[bug]	Using both <isc/net.h> and <lwres/net.h> didn't work on platforms lacking IPv6 because each included their own ipv6 header file for the missing definitions. Now each library's ipv6.h defines the wrapper symbol of the other (ISC_IPV6_H and LWRES_IPV6_H).
299.	[cleanup]	Get the user and group information before changing the root directory, so the administrator does not need to keep a copy of the user and group databases in the chroot'ed environment. Suggested by Hakan Olsson.
298.	[bug]	A mutex deadlock occurred during shutdown of the interface manager under certain conditions. Digital Unix systems were the most affected.
297.	[bug]	Specifying a key name that wasn't fully qualified in certain parts of the config file could cause an assertion failure.
296.	[bug]	"make install" from a separate build directory failed unless configure had been run in the source directory, too.
295.	[bug]	When invoked with type==CNAME and a message not constructed by dns_message_parse(), dns_message_findname() failed to find anything

(continues on next page)

(continued from previous page)

		due to checking for attribute bits that are set only in <code>dns_message_parse()</code> . This caused an infinite loop when constructing the response to an ANY query at a CNAME in a secure zone.
294.	[bug]	If we run out of space in while processing glue when reading a master file and commit "current name" reverts to "name_current" instead of staying as "name_glue".
293.	[port]	Add support for FreeBSD 4.0 system tests.
292.	[bug]	Due to problems with the way some operating systems handle simultaneous listening on IPv4 and IPv6 addresses, the server no longer listens on IPv6 addresses by default. To revert to the previous behavior, specify "listen-on-v6 { any; };" in the config file.
291.	[func]	Caching servers no longer send outgoing queries over TCP just because the incoming recursive query was a TCP one.
290.	[cleanup]	+twiddle option to dig (for testing only) removed.
289.	[cleanup]	dig is now installed in <code>\$bindir</code> instead of <code>\$sbindir</code> . host is now installed in <code>\$bindir</code> . (Be sure to remove any <code>\$sbindir/dig</code> from a previous release.)
288.	[func]	rndc is now installed by "make install" into <code>\$sbindir</code> .
287.	[bug]	rndc now works again as "rndc 127.1 reload" (for only that task). Parsing its configuration file and using digital signatures for authentication has been disabled until named supports the "controls" statement, post-9.0.0.
286.	[bug]	On Solaris 2, when named inherited a signal state where SIGHUP had the SIG_IGN action, SIGHUP would be ignored rather than causing the server to reload its configuration.
285.	[bug]	A change made to the dst API for beta4 inadvertently broke OMAPI's creation of a dst key from an incoming message, causing an assertion to be triggered. Fixed.
284.	[func]	The DNSSEC key generation and signing tools now generate randomness from keyboard input on systems that lack <code>/dev/random</code> .
283.	[cleanup]	The 'lwresd' program is now a link to 'named'.

(continues on next page)

(continued from previous page)

- 282. [bug] The lexer now returns ISC\_R\_RANGE if parsed integer is too big for an unsigned long.
- 281. [bug] Fixed list of recognized config file category names.
- 280. [func] Add isc-config.sh, which can be used to more easily build applications that link with our libraries.
- 279. [bug] Private omapi function symbols shared between two or more files in libomapi.a were not namespace protected using the ISC convention of starting with the library name and two underscores ("omapi\_\_"...)
- 278. [bug] bin/named/logconf.c:category\_fromconf() didn't take note of when isc\_log\_categorybyname() wasn't able to find the category name and would then apply the channel list of the unknown category to all categories.
- 277. [bug] isc\_log\_categorybyname() and isc\_log\_modulebyname() would fail to find the first member of any category or module array apart from the internal defaults. Thus, for example, the "notify" category was improperly configured by named.
- 276. [bug] dig now supports maximum sized TCP messages.
- 275. [bug] The definition of lwres\_gai\_strerror() was missing the lwres\_ prefix.
- 274. [bug] TSIG AXFR verify failed when talking to a BIND 8 server.
- 273. [func] The default for the 'transfer-format' option is now 'many-answers'. This will break zone transfers to BIND 4.9.5 and older unless there is an explicit 'one-answer' configuration.
- 272. [bug] The sending of large TCP responses was canceled in mid-transmission due to a race condition caused by the failure to set the client object's "newstate" variable correctly when transitioning to the "working" state.
- 271. [func] Attempt to probe the number of cpus in named if unspecified rather than defaulting to 1.
- 270. [func] Allow maximum sized TCP answers.
- 269. [bug] Failed DNSSEC validations could cause an assertion failure by causing clone\_results() to be called with with hevent->node == NULL.

(continues on next page)

(continued from previous page)

- 268. [doc] A plain text version of the Administrator Reference Manual is now included in the distribution, as doc/arm/Bv9ARM.txt.
- 267. [func] Nsupdate is now provided in the distribution.
- 266. [bug] zone.c:save\_nsrrset() node was not initialized.
- 265. [bug] dns\_request\_create() now works for TCP.
- 264. [func] Dispatch can not take TCP sockets in connecting state. Set DNS\_DISPATCHATTR\_CONNECTED when calling dns\_dispatch\_createtcp() for connected TCP sockets or call dns\_dispatch\_starttcp() when the socket is connected.
- 263. [func] New logging channel type 'stderr'
 

```

channel some-name {
    stderr;
    severity error;
}
      
```
- 262. [bug] 'master' was not initialized in zone.c:stub\_callback().
- 261. [func] Add dns\_zone\_markdirty().
- 260. [bug] Running named as a non-root user failed on Linux kernels new enough to support retaining capabilities after setuid().
- 259. [func] New random-device and random-seed-file statements for global options block of named.conf. Both accept a single string argument.
- 258. [bug] Fixed printing of lwres\_addr\_t.address field.
- 257. [bug] The server detached the last zone manager reference too early, while it could still be in use by queries. This manifested itself as assertion failures during the shutdown process for busy name servers. [RT #133]
- 256. [func] isc\_ratelimiter\_t now has attach/detach semantics, and isc\_ratelimiter\_shutdown guarantees that the rate limiter is detached from its task.
- 255. [func] New function dns\_zonemgr\_attach().
- 254. [bug] Suppress "query denied" messages on additional data lookups.

- ```

--- 9.0.0b4 released ---

253.  [func]      resolv.conf parser now recognizes ';' and '#' as
        comments (anywhere in line, not just as the beginning).

252.  [bug]      resolv.conf parser mishandled masks on sortlists.
        It also aborted when an unrecognized keyword was seen,
        now it silently ignores the entire line.

251.  [bug]      lwresd caught an assertion failure on startup.

250.  [bug]      fixed handling of size+unit when value would be too
        large for internal representation.

249.  [cleanup] max-cache-size config option now takes a size-spec
        like 'datasize', except 'default' is not allowed.

248.  [bug]      global lame-ttl option was not being printed when
        config structures were written out.

247.  [cleanup] Rename cache-size config option to max-cache-size.

246.  [func]      Rename global option cachesize to cache-size and
        add corresponding option to view statement.

245.  [bug]      If an uncompressed name will take more than 255
        bytes and the buffer is sufficiently long,
        dns_name_fromwire should return DNS_R_FORMERR,
        not ISC_R_NOSPACE. This bug caused cause the
        server to catch an assertion failure when it
        received a query for a name longer than 255
        bytes.

244.  [bug]      empty named.conf file and empty options statement are
        now parsed properly.

243.  [func]      new cachesize option for named.conf

242.  [cleanup]   fixed incorrect warning about auth-nxdomain usage.

241.  [cleanup]   nscount and soacount have been removed from the
        dns_master_*() argument lists.

240.  [func]      databases now come in three flavours: zone, cache
        and stub.

239.  [func]      If ISC_MEM_DEBUG is enabled, the variable
        isc_mem_debugging controls whether messages
        are printed or not.

238.  [cleanup]   A few more compilation warnings have been quieted:
        + missing sigwait prototype on BSD/OS 4.0/4.0.1.
        + PTHREAD_ONCE_INIT unbraced initializer warnings on
    
```

(continues on next page)

(continued from previous page)

|      |           |                                                                                                                                                                                                      |
|------|-----------|------------------------------------------------------------------------------------------------------------------------------------------------------------------------------------------------------|
|      |           | Solaris 2.8.<br>+ IN6ADDR_ANY_INIT unbraced initializer warnings on<br>BSD/OS 4.*, Linux and Solaris 2.8.                                                                                            |
| 237. | [bug]     | If connect() returned ENOBUFS when the resolver was<br>initiating a TCP query, the socket didn't get<br>destroyed, and the server did not shut down cleanly.                                         |
| 236. | [func]    | Added new listen-on-v6 config file statement.                                                                                                                                                        |
| 235. | [func]    | Consider it a config file error if a listen-on<br>statement has an IPv6 address in it, or a<br>listen-on-v6 statement has an IPv4 address in it.                                                     |
| 234. | [bug]     | Allow a trusted-key's first field (domain-name) be<br>either a quoted or an unquoted string, instead of<br>requiring a quoted string.                                                                |
| 233. | [cleanup] | Convert all config structure integer values to unsigned<br>integer (isc_uint32_t) to match grammar.                                                                                                  |
| 232. | [bug]     | Allow slave zones to not have a file.                                                                                                                                                                |
| 231. | [func]    | Support new 'port' clause in config file options<br>section. Causes 'listen-on', 'masters' and<br>'also-notify' statements to use its value instead of<br>default (53).                              |
| 230. | [func]    | Replace the dst sign/verify API with a cleaner one.                                                                                                                                                  |
| 229. | [func]    | Support config file sig-validity-interval statement<br>in options, views and zone statements (master<br>zones only).                                                                                 |
| 228. | [cleanup] | Logging messages in config module stripped of<br>trailing period.                                                                                                                                    |
| 227. | [cleanup] | The enumerated identifiers dns_rdataclass_*,<br>dns_rcode_*, dns_opcode_*, and dns_trust_* are<br>also now cast to their appropriate types, as with<br>dns_rdatatype_* in item number 225 below.     |
| 226. | [func]    | dns_name_totext() now always prints the root name as<br>'.', even when omit_final_dot is true.                                                                                                       |
| 225. | [cleanup] | The enumerated dns_rdatatype_* identifiers are now<br>cast to dns_rdatatype_t via macros of their same name<br>so that they are of the proper integral type wherever<br>a dns_rdatatype_t is needed. |
| 224. | [cleanup] | The entire project builds cleanly with gcc's<br>-Wcast-qual and -Wwrite-strings warnings enabled,                                                                                                    |

(continues on next page)

(continued from previous page)

|      |           |                                                                                                                                                                                              |
|------|-----------|----------------------------------------------------------------------------------------------------------------------------------------------------------------------------------------------|
|      |           | which is now the default when using gcc. (Warnings from confparser.c, because of yacc's code, are unfortunately to be expected.)                                                             |
| 223. | [func]    | Several functions were re-prototyped to qualify one or more of their arguments with "const". Similarly, several functions that return pointers now have those pointers qualified with const. |
| 222. | [bug]     | The global 'also-notify' option was ignored.                                                                                                                                                 |
| 221. | [bug]     | An uninitialized variable was sometimes passed to dns_rdata_freestruct() when loading a zone, causing an assertion failure.                                                                  |
| 220. | [cleanup] | Set the default outgoing port in the view, and set it in sockaddrs returned from the ADB.<br>[31-May-2000 explorer]                                                                          |
| 219. | [bug]     | Signed truncated messages more correctly follow the respective specs.                                                                                                                        |
| 218. | [func]    | When an rdataset is signed, its ttl is normalized based on the signature validity period.                                                                                                    |
| 217. | [func]    | Also-notify and trusted-keys can now be used in the 'view' statement.                                                                                                                        |
| 216. | [func]    | The 'max-cache-ttl' and 'max-ncache-ttl' options now work.                                                                                                                                   |
| 215. | [bug]     | Failures at certain points in request processing could cause the assertion INSIST(client->lockview == NULL) to be triggered.                                                                 |
| 214. | [func]    | New public function isc_netaddr_format(), for formatting network addresses in log messages.                                                                                                  |
| 213. | [bug]     | Don't leak memory when reloading the zone if an update-policy clause was present in the old zone.                                                                                            |
| 212. | [func]    | Added dns_message_get/settsigkey, to make TSIG key management reasonable.                                                                                                                    |
| 211. | [func]    | The 'key' and 'server' statements can now occur inside 'view' statements.                                                                                                                    |
| 210. | [bug]     | The 'allow-transfer' option was ignored for slave zones, and the 'transfers-per-ns' option was ignored for all zones.                                                                        |
| 209. | [cleanup] | Upgraded openssl files to new version 0.9.5a                                                                                                                                                 |

(continues on next page)

(continued from previous page)

- 208. [func] Added ISC\_OFFSET\_MAXIMUM for the maximum value of an isc\_offset\_t.
- 207. [func] The dnssec tools properly use the logging subsystem.
- 206. [cleanup] dst now stores the key name as a dns\_name\_t, not a char \*.
- 205. [cleanup] On IRIX, turn off the mostly harmless warnings 1692 ("prototyped function redeclared without prototype") and 1552 ("variable ... set but not used") when compiling in the lib/dns/sec/{dnssafe,openssl} directories, which contain code imported from outside sources.
- 204. [cleanup] On HP/UX, pass +vnocompatwarnings to the linker to quiet the warnings that "The linked output may not run on a PA 1.x system."
- 203. [func] notify and zone soa queries are now tsig signed when appropriate.
- 202. [func] isc\_lex\_getsourceline() changed from returning int to returning unsigned long, the type of its underlying counter.
- 201. [cleanup] Removed the test/sdig program, it has been replaced by bin/dig/dig.

--- 9.0.0b3 released ---

- 200. [bug] Failures in sending query responses to clients (e.g., running out of network buffers) were not logged.
- 199. [bug] isc\_heap\_delete() sometimes violated the heap invariant, causing timer events not to be posted when due.
- 198. [func] Dispatch managers hold memory pools which any managed dispatcher may use. This allows us to avoid dipping into the memory context for most allocations. [19-May-2000 explorer]
- 197. [bug] When an incoming AXFR or IXFR completes, the zone's internal state is refreshed from the SOA data. [19-May-2000 explorer]
- 196. [func] Dispatchers can be shared easily between views and/or interfaces. [19-May-2000 explorer]

(continues on next page)

(continued from previous page)

|      |           |                                                                                                                                                                                                                                                                                                                                                                                                                                                                                                                                                                                                                                                                                                                                                       |
|------|-----------|-------------------------------------------------------------------------------------------------------------------------------------------------------------------------------------------------------------------------------------------------------------------------------------------------------------------------------------------------------------------------------------------------------------------------------------------------------------------------------------------------------------------------------------------------------------------------------------------------------------------------------------------------------------------------------------------------------------------------------------------------------|
| 195. | [bug]     | Including the NXT record of the root domain in a negative response caused an assertion failure.                                                                                                                                                                                                                                                                                                                                                                                                                                                                                                                                                                                                                                                       |
| 194. | [doc]     | The PDF version of the Administrator's Reference Manual is no longer included in the ISC BIND9 distribution.                                                                                                                                                                                                                                                                                                                                                                                                                                                                                                                                                                                                                                          |
| 193. | [func]    | changed <code>dst_key_free()</code> prototype.                                                                                                                                                                                                                                                                                                                                                                                                                                                                                                                                                                                                                                                                                                        |
| 192. | [bug]     | Zone configuration validation is now done at end of config file parsing, and before loading callbacks.                                                                                                                                                                                                                                                                                                                                                                                                                                                                                                                                                                                                                                                |
| 191. | [func]    | Patched to compile on UnixWare 7.x. This platform is not directly supported by the ISC.                                                                                                                                                                                                                                                                                                                                                                                                                                                                                                                                                                                                                                                               |
| 190. | [cleanup] | <p>The DNSSEC tools have been moved to a separate directory <code>dnssec/</code> and given the following new, more descriptive names:</p> <pre> dnssec-keygen dnssec-signzone dnssec-signkey dnssec-makekeyset </pre> <p>Their command line arguments have also been changed to be more consistent. <code>dnssec-keygen</code> now prints the name of the generated key files (sans extension) on standard output to simplify its use in automated scripts.</p>                                                                                                                                                                                                                                                                                       |
| 189. | [func]    | <p><code>isc_time_secondsastimet()</code>, a new function, will ensure that the number of seconds in an <code>isc_time_t</code> does not exceed the range of a <code>time_t</code>, or return <code>ISC_R_RANGE</code>. Similarly, <code>isc_time_now()</code>, <code>isc_time_nowplusinterval()</code>, <code>isc_time_add()</code> and <code>isc_time_subtract()</code> now check the range for overflow/underflow. In the case of <code>isc_time_subtract</code>, this changed a calling requirement (ie, something that could generate an assertion) into merely a condition that returns an error result. <code>isc_time_add()</code> and <code>isc_time_subtract()</code> were void-valued before but now return <code>isc_result_t</code>.</p> |
| 188. | [func]    | Log a warning message when an incoming zone transfer contains out-of-zone data.                                                                                                                                                                                                                                                                                                                                                                                                                                                                                                                                                                                                                                                                       |
| 187. | [func]    | <code>isc_ratelimiter_enqueue()</code> has an additional argument 'task'.                                                                                                                                                                                                                                                                                                                                                                                                                                                                                                                                                                                                                                                                             |
| 186. | [func]    | <code>dns_request_getresponse()</code> has an additional argument 'preserve_order'.                                                                                                                                                                                                                                                                                                                                                                                                                                                                                                                                                                                                                                                                   |

(continues on next page)

(continued from previous page)

- 185. [bug] Fixed up handling of ISC\_MEMCLUSTER\_LEGACY. Several public functions did not have an isc\_\_ prefix, and referred to functions that had previously been renamed.
- 184. [cleanup] Variables/functions which began with two leading underscores were made to conform to the ANSI/ISO standard, which says that such names are reserved.
- 183. [func] ISC\_LOG\_PRINTTAG option for log channels. Useful for logging the program name or other identifier.
- 182. [cleanup] New command-line parameters for dnssec tools
- 181. [func] Added dst\_key\_buildfilename and dst\_key\_parsefilename
- 180. [func] New isc\_result\_t ISC\_R\_RANGE. Supersedes DNS\_R\_RANGE.
- 179. [func] options named.conf statement \*must\* now come before any zone or view statements.
- 178. [func] Post-load of named.conf check verifies a slave zone has non-empty list of masters defined.
- 177. [func] New per-zone boolean:
  - enable-zone yes | no ;
 intended to let a zone be disabled without having to comment out the entire zone statement.
- 176. [func] New global and per-view option:
  - max-cache-ttl number
- 175. [func] New global and per-view option:
  - additional-data internal | minimal | maximal;
- 174. [func] New public function isc\_sockaddr\_format(), for formatting socket addresses in log messages.
- 173. [func] Keep a queue of zones waiting for zone transfer quota so that a new transfer can be dispatched immediately whenever quota becomes available.
- 172. [bug] \$TTL directive was sometimes missing from dumped master files because totext\_ctx\_init() failed to initialize ctx->current\_ttl\_valid.
- 171. [cleanup] On NetBSD systems, the mit-pthreads or

(continues on next page)

(continued from previous page)

|      |           |                                                                                                                                                                                                                                                                                                                                |
|------|-----------|--------------------------------------------------------------------------------------------------------------------------------------------------------------------------------------------------------------------------------------------------------------------------------------------------------------------------------|
|      |           | unproven-pthreads library is now always used unless --with-plt2 is explicitly specified on the configure command line. The --with-mit-pthreads option is no longer needed and has been removed.                                                                                                                                |
| 170. | [cleanup] | Remove inter server consistency checks from zone, these should return as a separate module in 9.1. dns_zone_checkservers(), dns_zone_checkparents(), dns_zone_checkchildren(), dns_zone_checkglue().<br><br>Remove dns_zone_setadb(), dns_zone_setresolver(), dns_zone_setrequestmgr() these should now be found via the view. |
| 169. | [func]    | ratelimiter can now process N events per interval.                                                                                                                                                                                                                                                                             |
| 168. | [bug]     | include statements in named.conf caused syntax errors due to not consuming the semicolon ending the include statement before switching input streams.                                                                                                                                                                          |
| 167. | [bug]     | Make lack of masters for a slave zone a soft error.                                                                                                                                                                                                                                                                            |
| 166. | [bug]     | Keygen was overwriting existing keys if key_id conflicted, now it will retry, and non-null keys with key_id == 0 are not generated anymore. Key was not able to generate NOAUTHCONF DSA key, increased RSA key size to 2048 bits.                                                                                              |
| 165. | [cleanup] | Silence "end-of-loop condition not reached" warnings from Solaris compiler.                                                                                                                                                                                                                                                    |
| 164. | [func]    | Added functions isc_stdio_open(), isc_stdio_close(), isc_stdio_seek(), isc_stdio_read(), isc_stdio_write(), isc_stdio_flush(), isc_stdio_sync(), isc_file_remove() to encapsulate nonportable usage of errno and sync.                                                                                                         |
| 163. | [func]    | Added result codes ISC_R_FILENOTFOUND and ISC_R_FILEEXISTS.                                                                                                                                                                                                                                                                    |
| 162. | [bug]     | Ensure proper range for arguments to ctype.h functions.                                                                                                                                                                                                                                                                        |
| 161. | [cleanup] | error in yyparse prototype that only HPUX caught.                                                                                                                                                                                                                                                                              |
| 160. | [cleanup] | getnet*() are not going to be implemented at this stage.                                                                                                                                                                                                                                                                       |
| 159. | [func]    | Redefinition of config file elements is now an error (instead of a warning).                                                                                                                                                                                                                                                   |
| 158. | [bug]     | Log channel and category list copy routines weren't assigning properly to output parameter.                                                                                                                                                                                                                                    |

(continues on next page)

(continued from previous page)

- 157. [port] Fix missing prototype for getopt().
- 156. [func] Support new 'database' statement in zone.  

```
database "quoted-string";
```
- 155. [bug] ns\_notify\_start() was not detaching the found zone.
- 154. [func] The signer now logs libdns warnings to stderr even when not verbose, and in a nicer format.
- 153. [func] dns\_rdata\_tostruct() 'mctx' is now optional. If 'mctx' is NULL then you need to preserve the 'rdata' until you have finished using the structure as there may be references to the associated memory. If 'mctx' is non-NULL it is guaranteed that there are no references to memory associated with 'rdata'.  
  
 dns\_rdata\_freestruct() must be called if 'mctx' was non-NULL and may safely be called if 'mctx' was NULL.
- 152. [bug] keygen dumped core if domain name argument was omitted from command line.
- 151. [func] Support 'disabled' statement in zone config (causes zone to be parsed and then ignored). Currently must come after the 'type' clause.
- 150. [func] Support optional ports in masters and also-notify statements:  

```
masters [ port xxx ] { y.y.y.y [ port zzz ] ; }
```
- 149. [cleanup] Removed unused argument 'olist' from dns\_c\_view\_unsetordering().
- 148. [cleanup] Stop issuing some warnings about some configuration file statements that were not implemented, but now are.
- 147. [bug] Changed yacc union size to be smaller for yaccs that put yacc-stack on the real stack.
- 146. [cleanup] More general redundant header file cleanup. Rather than continuing to itemize every header which changed, this changelog entry just notes that if a header file did not need another header file that it was including in order to provide its advertised functionality, the inclusion of the other header file was removed. See util/check-includes for how this was tested.
- 145. [cleanup] Added <isc/lang.h> and ISC\_LANG\_BEGINDECLS/

(continues on next page)

(continued from previous page)

|      |           |                                                                                                                                                                                  |
|------|-----------|----------------------------------------------------------------------------------------------------------------------------------------------------------------------------------|
|      |           | ISC_LANG_ENDDECLS to header files that had function prototypes, and removed it from those that did not.                                                                          |
| 144. | [cleanup] | libdns header files too numerous to name were made to conform to the same style for multiple inclusion protection.                                                               |
| 143. | [func]    | Added function dns_rdatatype_isknown().                                                                                                                                          |
| 142. | [cleanup] | <isc/stdtime.h> does not need <time.h> or <isc/result.h>.                                                                                                                        |
| 141. | [bug]     | Corrupt requests with multiple questions could cause an assertion failure.                                                                                                       |
| 140. | [cleanup] | <isc/time.h> does not need <time.h> or <isc/result.h>.                                                                                                                           |
| 139. | [cleanup] | <isc/net.h> now includes <isc/types.h> instead of <isc/int.h> and <isc/result.h>.                                                                                                |
| 138. | [cleanup] | isc_strtoug moved from str.[ch] to string.[ch] and renamed isc_string_touint64. isc_strsep moved from strsep.c to string.c and renamed isc_string_separate.                      |
| 137. | [cleanup] | <isc/commandline.h>, <isc/mem.h>, <isc/print.h> <isc/serial.h>, <isc/string.h> and <isc/offset.h> made to conform to the same style for multiple inclusion protection.           |
| 136. | [cleanup] | <isc/commandline.h>, <isc/interfaceiter.h>, <isc/net.h> and Win32's <isc/thread.h> needed ISC_LANG_BEGINDECLS/ISC_LANG_ENDDECLS.                                                 |
| 135. | [cleanup] | Win32's <isc/condition.h> did not need <isc/result.h> or <isc/boolean.h>, now uses <isc/types.h> in place of <isc/time.h>, and needed ISC_LANG_BEGINDECLS and ISC_LANG_ENDDECLS. |
| 134. | [cleanup] | <isc/dir.h> does not need <limits.h>.                                                                                                                                            |
| 133. | [cleanup] | <isc/ipv6.h> needs <isc/platform.h>.                                                                                                                                             |
| 132. | [cleanup] | <isc/app.h> does not need <isc/task.h>, but does need <isc/eventclass.h>.                                                                                                        |
| 131. | [cleanup] | <isc/mutex.h> and <isc/util.h> need <isc/result.h> for ISC_R_* codes used in macros.                                                                                             |
| 130. | [cleanup] | <isc/condition.h> does not need <pthread.h> or <isc/boolean.h>, and now includes <isc/types.h> instead of <isc/time.h>.                                                          |

(continues on next page)

(continued from previous page)

- 129. [bug] The 'default\_debug' log channel was not set up when 'category default' was present in the config file
- 128. [cleanup] <isc/dir.h> had ISC\_LANG\_BEGINDECLS instead of ISC\_LANG\_ENDDECLS at end of header.
- 127. [cleanup] The contracts for the comparison routines dns\_name\_fullcompare(), dns\_name\_compare(), dns\_name\_rdatacompare(), and dns\_rdata\_compare() now specify that the order value returned is < 0, 0, or > 0 instead of -1, 0, or 1.
- 126. [cleanup] <isc/quota.h> and <isc/taskpool.h> need <isc/lang.h>.
- 125. [cleanup] <isc/eventclass.h>, <isc/ipv6.h>, <isc/magic.h>, <isc/mutex.h>, <isc/once.h>, <isc/region.h>, and <isc/resultclass.h> do not need <isc/lang.h>.
- 124. [func] signer now imports parent's zone key signature and creates null keys/sets zone status bit for children when necessary
- 123. [cleanup] <isc/event.h> does not need <stddef.h>.
- 122. [cleanup] <isc/task.h> does not need <isc/mem.h> or <isc/result.h>.
- 121. [cleanup] <isc/symtab.h> does not need <isc/mem.h> or <isc/result.h>. Multiple inclusion protection symbol fixed from ISC\_SYMBOL\_H to ISC\_SYMTAB\_H. isc\_symtab\_t moved to <isc/types.h>.
- 120. [cleanup] <isc/socket.h> does not need <isc/boolean.h>, <isc/bufferlist.h>, <isc/task.h>, <isc/mem.h> or <isc/net.h>.
- 119. [cleanup] structure definitions for generic rdata structures do not have \_generic\_ in their names.
- 118. [cleanup] libdns.a is now namespace-clean, on NetBSD, excepting YACC crust (yyparse, etc) [2000-apr-27 explorer]
- 117. [cleanup] libdns.a changes:  
 dns\_zone\_clearnotify() and dns\_zone\_addnotify() are replaced by dns\_zone\_setnotifyalso().  
 dns\_zone\_clearmasters() and dns\_zone\_addmaster() are replaced by dns\_zone\_setmasters().
- 116. [func] Added <isc/offset.h> for isc\_offset\_t (aka off\_t on Unix systems).
- 115. [port] Shut up the -Wmissing-declarations warning about

(continues on next page)

(continued from previous page)

|      |           |                                                                                                                                                                                                                                                                                                                                                                                                                                                                                                                                                                                                                                                                                                            |
|------|-----------|------------------------------------------------------------------------------------------------------------------------------------------------------------------------------------------------------------------------------------------------------------------------------------------------------------------------------------------------------------------------------------------------------------------------------------------------------------------------------------------------------------------------------------------------------------------------------------------------------------------------------------------------------------------------------------------------------------|
|      |           | <stdio.h>'s __sputaux on BSD/OS pre-4.1.                                                                                                                                                                                                                                                                                                                                                                                                                                                                                                                                                                                                                                                                   |
| 114. | [cleanup] | <isc/sockaddr.h> does not need <isc/buffer.h> or <isc/list.h>.                                                                                                                                                                                                                                                                                                                                                                                                                                                                                                                                                                                                                                             |
| 113. | [func]    | Utility programs dig and host added.                                                                                                                                                                                                                                                                                                                                                                                                                                                                                                                                                                                                                                                                       |
| 112. | [cleanup] | <isc/serial.h> does not need <isc/boolean.h>.                                                                                                                                                                                                                                                                                                                                                                                                                                                                                                                                                                                                                                                              |
| 111. | [cleanup] | <isc/rwlock.h> does not need <isc/result.h> or <isc/mutex.h>.                                                                                                                                                                                                                                                                                                                                                                                                                                                                                                                                                                                                                                              |
| 110. | [cleanup] | <isc/result.h> does not need <isc/boolean.h> or <isc/list.h>.                                                                                                                                                                                                                                                                                                                                                                                                                                                                                                                                                                                                                                              |
| 109. | [bug]     | "make depend" did nothing for bin/tests/{db,mem,sockaddr,tasks,timers}/.                                                                                                                                                                                                                                                                                                                                                                                                                                                                                                                                                                                                                                   |
| 108. | [cleanup] | DNS_SETBIT/DNS_GETBIT/DNS_CLEARBIT moved from <dns/types.h> to <dns/bit.h> and renamed to DNS_BIT_SET/DNS_BIT_GET/DNS_BIT_CLEAR.                                                                                                                                                                                                                                                                                                                                                                                                                                                                                                                                                                           |
| 107. | [func]    | Add key signer and keysettool.                                                                                                                                                                                                                                                                                                                                                                                                                                                                                                                                                                                                                                                                             |
| 106. | [func]    | Allow dnssec verifications to ignore the validity period. Used by several of the dnssec tools.                                                                                                                                                                                                                                                                                                                                                                                                                                                                                                                                                                                                             |
| 105. | [doc]     | doc/dev/coding.html expanded with other implicit conventions the developers have used.                                                                                                                                                                                                                                                                                                                                                                                                                                                                                                                                                                                                                     |
| 104. | [bug]     | Made compress_add and compress_find static to lib/dns/compress.c.                                                                                                                                                                                                                                                                                                                                                                                                                                                                                                                                                                                                                                          |
| 103. | [func]    | libisc buffer API changes for <isc/buffer.h>:<br>Added:<br>isc_buffer_base(b)                   (pointer)<br>isc_buffer_current(b)               (pointer)<br>isc_buffer_active(b)               (pointer)<br>isc_buffer_used(b)                 (pointer)<br>isc_buffer_length(b)               (int)<br>isc_buffer_usedlength(b)           (int)<br>isc_buffer_consumedlength(b)       (int)<br>isc_buffer_remaininglength(b)      (int)<br>isc_buffer_activelength(b)       (int)<br>isc_buffer_availablelength(b)      (int)<br>Removed:<br>ISC_BUFFER_USEDCOUNT(b)<br>ISC_BUFFER_AVAILABLECOUNT(b)<br>isc_buffer_type(b)<br>Changed names:<br>isc_buffer_used(b, r) -><br>isc_buffer_usedregion(b, r) |

(continues on next page)

(continued from previous page)

```
isc_buffer_available(b, r) ->
    isc_buffer_available_region(b, r)
isc_buffer_consumed(b, r) ->
    isc_buffer_consumedregion(b, r)
isc_buffer_active(b, r) ->
    isc_buffer_activeregion(b, r)
isc_buffer_remaining(b, r) ->
    isc_buffer_remainingregion(b, r)
```

Buffer types were removed, so the ISC\_BUFFERTYPE\_\* macros are no more, and the type argument to `isc_buffer_init` and `isc_buffer_allocate` were removed. `isc_buffer_putstr` is now void (instead of `isc_result_t`) and requires that the caller ensure that there is enough available buffer space for the string.

- 102. [port] Correctly detect `inet_aton`, `inet_pton` and `inet_ptop` on BSD/OS 4.1.
- 101. [cleanup] Quieted EGCS warnings from `lib/isc/print.c`.
- 100. [cleanup] `<isc/random.h>` does not need `<isc/int.h>` or `<isc/mutex.h>`. `isc_random_t` moved to `<isc/types.h>`.
- 99. [cleanup] Rate limiter now has separate `shutdown()` and `destroy()` functions, and it guarantees that all queued events are delivered even in the shutdown case.
- 98. [cleanup] `<isc/print.h>` does not need `<stdarg.h>` or `<stddef.h>` unless `ISC_PLATFORM_NEEDVSNPRINTF` is defined.
- 97. [cleanup] `<isc/ondestroy.h>` does not need `<stddef.h>` or `<isc/event.h>`.
- 96. [cleanup] `<isc/mutex.h>` does not need `<isc/result.h>`.
- 95. [cleanup] `<isc/mutexblock.h>` does not need `<isc/result.h>`.
- 94. [cleanup] Some installed header files did not compile as C++.
- 93. [cleanup] `<isc/msgcat.h>` does not need `<isc/result.h>`.
- 92. [cleanup] `<isc/mem.h>` does not need `<stddef.h>`, `<isc/boolean.h>`, or `<isc/result.h>`.
- 91. [cleanup] `<isc/log.h>` does not need `<sys/types.h>` or `<isc/result.h>`.
- 90. [cleanup] Removed unneeded `ISC_LANG_BEGINDECLS/ISC_LANG_ENDDECLS` from `<named/listenlist.h>`.
- 89. [cleanup] `<isc/lex.h>` does not need `<stddef.h>`.

(continues on next page)

(continued from previous page)

- 88. [cleanup] <isc/interfaceiter.h> does not need <isc/result.h> or <isc/mem.h>. `isc_interface_t` and `isc_interfaceiter_t` moved to <isc/types.h>.
- 87. [cleanup] <isc/heap.h> does not need <isc/boolean.h>, <isc/mem.h> or <isc/result.h>.
- 86. [cleanup] `isc_bufferlist_t` moved from <isc/bufferlist.h> to <isc/types.h>.
- 85. [cleanup] <isc/bufferlist.h> does not need <isc/buffer.h>, <isc/list.h>, <isc/mem.h>, <isc/region.h> or <isc/int.h>.
- 84. [func] allow-query ACL checks now apply to all data added to a response.
- 83. [func] If the server is authoritative for both a delegating zone and its (nonsecure) delegatee, and a query is made for a KEY RR at the top of the delegatee, then the server will look for a KEY in the delegator if it is not found in the delegatee.
- 82. [cleanup] <isc/buffer.h> does not need <isc/list.h>.
- 81. [cleanup] <isc/int.h> and <isc/boolean.h> do not need <isc/lang.h>.
- 80. [cleanup] <isc/print.h> does not need <stdio.h> or <stdlib.h>.
- 79. [cleanup] <dns/callbacks.h> does not need <stdio.h>.
- 78. [cleanup] `lwres_confstest` renamed to `lwresconf_test` for consistency with other \*\_test programs.
- 77. [cleanup] typedef of `isc_time_t` and `isc_interval_t` moved from <isc/time.h> to <isc/types.h>.
- 76. [cleanup] Rewrote `keygen`.
- 75. [func] Don't load a zone if its database file is older than the last time the zone was loaded.
- 74. [cleanup] Removed `mktemplate.o` and `ufile.o` from `libisc.a`, subsumed by `file.o`.
- 73. [func] New "file" API in `libisc`, including new function `isc_file_getmodtime`, `isc_mktemplate` renamed to `isc_file_mktemplate` and `isc_ufile` renamed to `isc_file_openunique`. By no means an exhaustive API, it is just what's needed for now.

(continues on next page)

(continued from previous page)

- 72. [func] DNS\_RBTFIND\_NOPREDECESSOR and DNS\_RBTFIND\_NOOPTIONS added for `dns_rbt_findnode`, the former to disable the setting of the chain to the predecessor, and the latter to make clear when no options are set.
- 71. [cleanup] Made explicit the implicit REQUIRES of `isc_time_seconds`, `isc_time_nanoseconds`, and `isc_time_subtract`.
- 70. [func] `isc_time_set()` added.
- 69. [bug] The zone object's master and also-notify lists grew longer with each server reload.
- 68. [func] Partial support for SIG(0) on incoming messages.
- 67. [performance] Allow use of alternate (compile-time supplied) OpenSSL libraries/headers.
- 66. [func] Data in authoritative zones should have a trust level beyond secure.
- 65. [cleanup] Removed obsolete typedef of `dns_zone_callbackarg_t` from `<dns/types.h>`.
- 64. [func] The RBT, DB, and zone table APIs now allow the caller find the most-enclosing superdomain of a name.
- 63. [func] Generate NOTIFY messages.
- 62. [func] Add UDP refresh support.
- 61. [cleanup] Use single quotes consistently in log messages.
- 60. [func] Catch and disallow singleton types on message parse.
- 59. [bug] Cause net/host unreachable to be a hard error when sending and receiving.
- 58. [bug] `bin/named/query.c` could sometimes trigger the `(client->query.attributes & NS_QUERYATTR_NAMEBUFUSED) == 0` assertion in `query_newname()`.
- 57. [func] Added `dns_nxt_typepresent()`
- 56. [bug] SIG records were not properly returned in cached negative answers.
- 55. [bug] Responses containing multiple names in the authority

(continues on next page)

(continued from previous page)

|     |           |                                                                                                                                                                |
|-----|-----------|----------------------------------------------------------------------------------------------------------------------------------------------------------------|
|     |           | section were not negatively cached.                                                                                                                            |
| 54. | [bug]     | If a fetch with sigrdataset==NULL joined one with sigrdataset!=NULL or vice versa, the resolver could catch an assertion or lose signature data, respectively. |
| 53. | [port]    | freebsd 4.0: lib/isc/unix/socket.c requires <sys/param.h>.                                                                                                     |
| 52. | [bug]     | rndc: taskmgr and socketmgr were not initialized to NULL.                                                                                                      |
| 51. | [cleanup] | dns/compress.h and dns/zt.h did not need to include dns/rbt.h; it was needed only by compress.c and zt.c.                                                      |
| 50. | [func]    | RBT deletion no longer requires a valid chain to work, and dns_rbt_deletenode was added.                                                                       |
| 49. | [func]    | Each cache now has its own mctx.                                                                                                                               |
| 48. | [func]    | isc_task_create() no longer takes an mctx. isc_task_mem() has been eliminated.                                                                                 |
| 47. | [func]    | A number of modules now use memory context reference counting.                                                                                                 |
| 46. | [func]    | Memory contexts are now reference counted. Added isc_mem_inuse() and isc_mem_preallocate(). Renamed isc_mem_destroy_check() to isc_mem_setdestroycheck().      |
| 45. | [bug]     | The trusted-key statement incorrectly loaded keys.                                                                                                             |
| 44. | [bug]     | Don't include authority data if it would force us to unset the AD bit in the message.                                                                          |
| 43. | [bug]     | DNSSEC verification of cached rdatasets was failing.                                                                                                           |
| 42. | [cleanup] | Simplified logging of messages with embedded domain names by introducing a new convenience function dns_name_format().                                         |
| 41. | [func]    | Use PR_SET_KEEPCAPS on Linux 2.3.99-pre3 and later to allow 'named' to run as a non-root user while retaining the ability to bind() to privileged ports.       |
| 40. | [func]    | Introduced new logging category "dnssec" and logging module "dns/validator".                                                                                   |
| 39. | [cleanup] | Moved the typedefs for isc_region_t, isc_textregion_t,                                                                                                         |

(continues on next page)

(continued from previous page)

- and `isc_lex_t` to `<isc/types.h>`.
- 38. [bug] TSIG signed incoming zone transfers work now.
- 37. [bug] If the first RR in an incoming zone transfer was not an SOA, the server died with an assertion failure instead of just reporting an error.
- 36. [cleanup] Change `DNS_R_SUCCESS` (and others) to `ISC_R_SUCCESS`
- 35. [performance] Log messages which are of a level too high to be logged by any channel in the logging configuration will not cause the log mutex to be locked.
- 34. [bug] Recursion was allowed even with 'recursion no'.
- 33. [func] The RBT now maintains a parent pointer at each node.
- 32. [cleanup] `bin/lwresd/client.c` needs `<string.h>` for `memset()` prototype.
- 31. [bug] Use `${LIBTOOL}` to compile `bin/named/main.@O@`.
- 30. [func] config file grammar change to support optional class type for a view.
- 29. [func] support new config file view options:

```

auth-nxdomain recursion query-source
query-source-v6 transfer-source
transfer-source-v6 max-transfer-time-out
max-transfer-idle-out transfer-format
request-ixfr provide-ixfr cleaning-interval
fetch-glue notify rfc2308-type1 lame-ttl
max-ncache-ttl min-roots
                
```
- 28. [func] support `lame-ttl`, `min-roots` and `serial-queries` config global options.
- 27. [bug] Only include `<netinet6/in6.h>` on BSD/OS 4.[01]\*. Including it on other platforms (eg, NetBSD) can cause a forced `#error` from the C preprocessor.
- 26. [func] new `match-clients` statement in config file view.
- 25. [bug] `make install` failed to install `<isc/log.h>` and `<isc/ondestroy.h>`.
- 24. [cleanup] Eliminate some unnecessary `#includes` of header files from header files.
- 23. [cleanup] Provide more context in log messages about client

(continues on next page)

(continued from previous page)

|     |           |                                                                                                                                                                                                                                                                                                                              |
|-----|-----------|------------------------------------------------------------------------------------------------------------------------------------------------------------------------------------------------------------------------------------------------------------------------------------------------------------------------------|
|     |           | requests, using a new function <code>ns_client_log()</code> .                                                                                                                                                                                                                                                                |
| 22. | [bug]     | SIGs weren't returned in the answer section when the query resulted in a fetch.                                                                                                                                                                                                                                              |
| 21. | [port]    | Look at <code>STD_CINCLUDES</code> after <code>CINCLUDES</code> during compilation, so additional system include directories can be searched but header files in the bind9 source tree with conflicting names take precedence. This avoids issues with installed versions of <code>dnssafe</code> and <code>openssl</code> . |
| 20. | [func]    | Configuration file post-load validation of zones failed if there were no zones.                                                                                                                                                                                                                                              |
| 19. | [bug]     | <code>dns_zone_notifyreceive()</code> failed to unlock the zone lock in certain error cases.                                                                                                                                                                                                                                 |
| 18. | [bug]     | Use <code>AC_TRY_LINK</code> rather than <code>AC_TRY_COMPILE</code> in <code>configure.in</code> to check for presence of <code>in6addr_any</code> .                                                                                                                                                                        |
| 17. | [func]    | Do configuration file post-load validation of zones.                                                                                                                                                                                                                                                                         |
| 16. | [bug]     | put quotes around key names on config file output to avoid possible keyword clashes.                                                                                                                                                                                                                                         |
| 15. | [func]    | Add <code>dns_name_dupwithoffsets()</code> . This function improves comparison performance for duped names.                                                                                                                                                                                                                  |
| 14. | [bug]     | <code>free_rbtodb()</code> could have 'put' unallocated memory in an unlikely error path.                                                                                                                                                                                                                                    |
| 13. | [bug]     | <code>lib/dns/master.c</code> and <code>lib/dns/xfrin.c</code> didn't ignore out-of-zone data.                                                                                                                                                                                                                               |
| 12. | [bug]     | Fixed possible uninitialized variable error.                                                                                                                                                                                                                                                                                 |
| 11. | [bug]     | <code>axfr_rrstream_first()</code> didn't check the result code of <code>db_rr_iterator_first()</code> , possibly causing an assertion to be triggered later.                                                                                                                                                                |
| 10. | [bug]     | A bug in the code which makes EDNS0 OPT records in <code>bin/named/client.c</code> and <code>lib/dns/resolver.c</code> could trigger an assertion.                                                                                                                                                                           |
| 9.  | [cleanup] | replaced bit-setting code in <code>confctx.c</code> and replaced repeated code with macro calls.                                                                                                                                                                                                                             |
| 8.  | [bug]     | Shutdown of incoming zone transfer accessed freed memory.                                                                                                                                                                                                                                                                    |
| 7.  | [cleanup] | removed 'listen-on' from view statement.                                                                                                                                                                                                                                                                                     |

(continues on next page)

(continued from previous page)

6. [bug] quote RR names when generating config file to prevent possible clash with config file keywords (such as 'key').
5. [func] syntax change to named.conf file: new ssu grant/deny statements must now be enclosed by an 'update-policy' block.
4. [port] bin/named/unix/os.c didn't compile on systems with linux 2.3 kernel includes due to conflicts between C library includes and the kernel includes. We now get only what we need from <linux/capability.h>, and avoid pulling in other linux kernel .h files.
3. [bug] TKEYs go in the answer section of responses, not the additional section.
2. [bug] Generating cryptographic randomness failed on systems without /dev/random.
1. [bug] The installdirs rule in lib/isc/unix/include/isc/Makefile.in had a typo which prevented the isc directory from being created if it didn't exist.

--- 9.0.0b2 released ---



## A BRIEF HISTORY OF THE DNS AND BIND

Although the Domain Name System "officially" began in 1984 with the publication of **RFC 920**, the core of the new system was described in 1983 in **RFC 882** and **RFC 883**. From 1984 to 1987, the ARPANet (the precursor to today's Internet) became a testbed of experimentation for developing the new naming/addressing scheme in a rapidly expanding, operational network environment. New RFCs were written and published in 1987 that modified the original documents to incorporate improvements based on the working model. **RFC 1034**, "Domain Names-Concepts and Facilities," and **RFC 1035**, "Domain Names-Implementation and Specification," were published and became the standards upon which all DNS implementations are built.

The first working domain name server, called "Jeeves," was written in 1983-84 by Paul Mockapetris for operation on DEC Tops-20 machines located at the University of Southern California's Information Sciences Institute (USC-ISI) and SRI International's Network Information Center (SRI-NIC). A DNS server for Unix machines, the Berkeley Internet Name Domain (BIND) package, was written soon after by a group of graduate students at the University of California at Berkeley under a grant from the US Defense Advanced Research Projects Administration (DARPA).

Versions of BIND through 4.8.3 were maintained by the Computer Systems Research Group (CSRG) at UC Berkeley. Douglas Terry, Mark Painter, David Riggle, and Songnian Zhou made up the initial BIND project team. After that, additional work on the software package was done by Ralph Campbell. Kevin Dunlap, a Digital Equipment Corporation employee on loan to the CSRG, worked on BIND for 2 years, from 1985 to 1987. Many other people also contributed to BIND development during that time: Doug Kingston, Craig Partridge, Smoot Carl-Mitchell, Mike Muuss, Jim Bloom, and Mike Schwartz. BIND maintenance was subsequently handled by Mike Karels and Øivind Kure.

BIND versions 4.9 and 4.9.1 were released by Digital Equipment Corporation (which became Compaq Computer Corporation and eventually merged with Hewlett-Packard). Paul Vixie, then a DEC employee, became BIND's primary caretaker. He was assisted by Phil Almquist, Robert Elz, Alan Barrett, Paul Albitz, Bryan Beecher, Andrew Partan, Andy Cherenon, Tom Limoncelli, Berthold Paffrath, Fuat Baran, Anant Kumar, Art Harkin, Win Treese, Don Lewis, Christophe Wolfhugel, and others.

In 1994, BIND version 4.9.2 was sponsored by Vixie Enterprises. Paul Vixie became BIND's principal architect/programmer.

BIND versions from 4.9.3 onward have been developed and maintained by Internet Systems Consortium and its predecessor, the Internet Software Consortium, with support provided by ISC's sponsors.

As co-architects/programmers, Bob Halley and Paul Vixie released the first production-ready version of BIND version 8 in May 1997.

BIND version 9 was released in September 2000 and is a major rewrite of nearly all aspects of the underlying BIND architecture.

BIND versions 4 and 8 are officially deprecated. No additional development is done on BIND version 4 or BIND version 8.

BIND development work is made possible today by the sponsorship of corporations who purchase professional support services from ISC (<https://www.isc.org/contact/>) and/or donate to our mission, and by the tireless efforts of numerous individuals.



## Non-alphabetical

- \$TTL, [32](#)
- +aaflag
  - dig command line option, [421](#)
  - mdig command line option, [459](#)
- +aaonly
  - dig command line option, [421](#)
  - mdig command line option, [459](#)
- +additional
  - dig command line option, [421](#)
  - mdig command line option, [457](#)
- +adflag
  - dig command line option, [421](#)
  - mdig command line option, [459](#)
- +all
  - delv command line option, [417](#)
  - dig command line option, [421](#)
  - mdig command line option, [457](#)
- +answer
  - dig command line option, [421](#)
  - mdig command line option, [457](#)
- +authority
  - dig command line option, [421](#)
  - mdig command line option, [457](#)
- +badcookie
  - dig command line option, [421](#)
- +besteffort
  - dig command line option, [421](#)
  - mdig command line option, [457](#)
- +bufsize
  - dig command line option, [421](#)
  - mdig command line option, [459](#)
- +burst
  - mdig command line option, [457](#)
- +cd
  - dig command line option, [421](#)
- +cdflag
  - delv command line option, [416](#)
  - dig command line option, [421](#)
  - mdig command line option, [459](#)
- +cl
  - mdig command line option, [457](#)
- +class
  - delv command line option, [417](#)
  - dig command line option, [421](#)
- +cmd
  - dig command line option, [421](#)
- +co
  - dig command line option, [422](#)
- +coflag
  - dig command line option, [422](#)
- +comments
  - delv command line option, [417](#)
  - dig command line option, [422](#)
  - mdig command line option, [457](#)
- +continue
  - mdig command line option, [458](#)
- +cookie
  - dig command line option, [422](#)
  - mdig command line option, [459](#)
- +crypto
  - delv command line option, [417](#)
  - dig command line option, [422](#)
  - mdig command line option, [458](#)
- +defname
  - dig command line option, [422](#)
- +dns64prefix
  - dig command line option, [422](#)
- +dnssec
  - delv command line option, [418](#)
  - dig command line option, [422](#)
  - mdig command line option, [459](#)
- +do
  - dig command line option, [422](#)
- +domain
  - dig command line option, [422](#)
- +dscp
  - dig command line option, [422](#)
  - mdig command line option, [458](#)
- +edns
  - dig command line option, [422](#)
  - mdig command line option, [459](#)
- +ednsflags
  - dig command line option, [422](#)

mdig command line option, 459

+ednsnegotiation  
    dig command line option, 422

+ednsopt  
    dig command line option, 422  
    mdig command line option, 459

+expire  
    dig command line option, 423  
    mdig command line option, 459

+fail  
    dig command line option, 423

+fuzztime  
    dig command line option, 423

+header-only  
    dig command line option, 423

+http-plain  
    dig command line option, 423

+http-plain-get  
    dig command line option, 423

+http-plain-post  
    dig command line option, 423

+https  
    dig command line option, 423

+https-get  
    dig command line option, 423

+https-post  
    dig command line option, 423

+identify  
    dig command line option, 423

+idnin  
    dig command line option, 423

+idnout  
    dig command line option, 423

+ignore  
    dig command line option, 424

+keepalive  
    dig command line option, 424

+keepopen  
    dig command line option, 424

+mtrace  
    delv command line option, 417

+multiline  
    delv command line option, 417  
    dig command line option, 424  
    mdig command line option, 458

+ndots  
    dig command line option, 424

+noaaflag  
    dig command line option, 421  
    mdig command line option, 459

+noaaonly  
    dig command line option, 421  
    mdig command line option, 459

+noadditional  
    dig command line option, 421  
    mdig command line option, 457

+noadflag  
    dig command line option, 421  
    mdig command line option, 459

+noall  
    delv command line option, 417  
    dig command line option, 421  
    mdig command line option, 457

+noanswer  
    dig command line option, 421  
    mdig command line option, 457

+noauthority  
    dig command line option, 421  
    mdig command line option, 457

+nobadcookie  
    dig command line option, 421

+nobesteffort  
    dig command line option, 421  
    mdig command line option, 457

+nocdflag  
    delv command line option, 416  
    dig command line option, 421  
    mdig command line option, 459

+nocl  
    mdig command line option, 457

+noclass  
    delv command line option, 417  
    dig command line option, 421

+nocmd  
    dig command line option, 421

+noco  
    dig command line option, 422

+nocoflag  
    dig command line option, 422

+nocomments  
    delv command line option, 417  
    dig command line option, 422  
    mdig command line option, 457

+nocontinue  
    mdig command line option, 458

+nocookie  
    dig command line option, 422  
    mdig command line option, 459

+nocrypto  
    delv command line option, 417  
    dig command line option, 422  
    mdig command line option, 458

+nodefname  
    dig command line option, 422

+nodns64prefix  
    dig command line option, 422

+nodnssec  
    delv command line option, 418

dig command line option, 422  
 mdig command line option, 459  
 +nodo  
     dig command line option, 422  
 +noedns  
     dig command line option, 422  
     mdig command line option, 459  
 +noednsflags  
     dig command line option, 422  
     mdig command line option, 459  
 +noednsnegotiation  
     dig command line option, 422  
 +noednsopt  
     dig command line option, 422  
     mdig command line option, 459  
 +noexpire  
     dig command line option, 423  
     mdig command line option, 459  
 +nofail  
     dig command line option, 423  
 +nofuzztime  
     dig command line option, 423  
 +noheader-only  
     dig command line option, 423  
 +nohttp-plain  
     dig command line option, 423  
 +nohttp-plain-get  
     dig command line option, 423  
 +nohttp-plain-post  
     dig command line option, 423  
 +nohttps  
     dig command line option, 423  
 +nohttps-get  
     dig command line option, 423  
 +nohttps-post  
     dig command line option, 423  
 +noidentify  
     dig command line option, 423  
 +noidnin  
     dig command line option, 423  
 +noidnout  
     dig command line option, 423  
 +noignore  
     dig command line option, 424  
 +nokeepalive  
     dig command line option, 424  
 +nokeepopen  
     dig command line option, 424  
 +nomtrace  
     delv command line option, 417  
 +nomultiline  
     delv command line option, 417  
     dig command line option, 424  
     mdig command line option, 458  
 +nonsid  
     dig command line option, 424  
     mdig command line option, 459  
 +nonssearch  
     dig command line option, 424  
 +noonesoa  
     dig command line option, 424  
 +noopcode  
     dig command line option, 424  
 +noqr  
     dig command line option, 424  
 +noquestion  
     dig command line option, 424  
     mdig command line option, 458  
 +noraflag  
     dig command line option, 425  
 +nordflag  
     dig command line option, 425  
 +norecurse  
     dig command line option, 425  
     mdig command line option, 460  
 +noroot  
     delv command line option, 418  
 +norrcomments  
     delv command line option, 417  
     dig command line option, 425  
     mdig command line option, 458  
 +nortrace  
     delv command line option, 417  
 +nosearch  
     dig command line option, 425  
 +noshort  
     delv command line option, 417  
     dig command line option, 425  
     mdig command line option, 458  
 +noshowbadcookie  
     dig command line option, 425  
 +noshowsearch  
     dig command line option, 425  
 +nosigchase  
     dig command line option, 425  
 +nosplit  
     delv command line option, 417  
 +nostats  
     dig command line option, 425  
 +nosubnet  
     dig command line option, 425  
     mdig command line option, 460  
 +notcflag  
     dig command line option, 426  
 +notcp  
     delv command line option, 418  
     dig command line option, 426  
     mdig command line option, 458

+notls  
    dig command line option, 426

+notls-ca  
    dig command line option, 426

+notls-certfile  
    dig command line option, 426

+notls-hostname  
    dig command line option, 426

+notls-keyfile  
    dig command line option, 426

+notopdown  
    dig command line option, 426

+notrace  
    dig command line option, 426

+notrust  
    delv command line option, 417

+nottl  
    delv command line option, 417

+nottlid  
    dig command line option, 426  
    mdig command line option, 458

+nottlunits  
    dig command line option, 426  
    mdig command line option, 458

+nunknownformat  
    delv command line option, 418  
    dig command line option, 427  
    mdig command line option, 460

+novc  
    dig command line option, 427  
    mdig command line option, 458

+novtrace  
    delv command line option, 417

+noyaml  
    delv command line option, 418  
    dig command line option, 427  
    mdig command line option, 460

+nozflag  
    dig command line option, 427  
    mdig command line option, 460

+nsid  
    dig command line option, 424  
    mdig command line option, 459

+nssearch  
    dig command line option, 424

+onesoa  
    dig command line option, 424

+opcode  
    dig command line option, 424

+padding  
    dig command line option, 424

+qid  
    dig command line option, 424

+qr  
    dig command line option, 424

    dig command line option, 424

+question  
    dig command line option, 424  
    mdig command line option, 458

+raflag  
    dig command line option, 425

+rdflag  
    dig command line option, 425

+recurse  
    dig command line option, 425  
    mdig command line option, 460

+retry  
    dig command line option, 425  
    mdig command line option, 460

+root  
    delv command line option, 418

+rrcomments  
    delv command line option, 417  
    dig command line option, 425  
    mdig command line option, 458

+rtrace  
    delv command line option, 417

+search  
    dig command line option, 425

+short  
    delv command line option, 417  
    dig command line option, 425  
    mdig command line option, 458

+showbadcookie  
    dig command line option, 425

+showsearch  
    dig command line option, 425

+sigchase  
    dig command line option, 425

+split  
    delv command line option, 417  
    dig command line option, 425  
    mdig command line option, 458

+stats  
    dig command line option, 425

+subnet  
    dig command line option, 425  
    mdig command line option, 460

+tcflag  
    dig command line option, 426

+tcp  
    delv command line option, 418  
    dig command line option, 426  
    mdig command line option, 458

+timeout  
    dig command line option, 426  
    mdig command line option, 460

+tls  
    dig command line option, 426

+tls-ca  
     dig command line option, 426

+tls-certfile  
     dig command line option, 426

+tls-hostname  
     dig command line option, 426

+tls-keyfile  
     dig command line option, 426

+topdown  
     dig command line option, 426

+trace  
     dig command line option, 426

+tries  
     dig command line option, 426  
     mdig command line option, 460

+trust  
     delv command line option, 417

+trusted-key  
     dig command line option, 426

+ttl  
     delv command line option, 417

+ttlid  
     dig command line option, 426  
     mdig command line option, 458

+ttlunits  
     dig command line option, 426  
     mdig command line option, 458

+udptimeout  
     mdig command line option, 460

+unknownformat  
     delv command line option, 418  
     dig command line option, 427  
     mdig command line option, 460

+vc  
     dig command line option, 427  
     mdig command line option, 458

+vtrace  
     delv command line option, 417

+yaml  
     delv command line option, 418  
     dig command line option, 427  
     mdig command line option, 460

+zflag  
     dig command line option, 427  
     mdig command line option, 460

-1  
     dnssec-dsfromkey command line option, 431

-2  
     dnssec-dsfromkey command line option, 431

-3  
     dnssec-keyfromlabel command line option, 434  
     dnssec-keygen command line option, 438  
     dnssec-signzone command line option, 450

-4  
     delv command line option, 416  
     dig command line option, 419  
     host command line option, 454  
     mdig command line option, 457  
     named command line option, 491  
     nsupdate command line option, 499  
     rndc command line option, 507

-6  
     delv command line option, 416  
     dig command line option, 419  
     host command line option, 454  
     mdig command line option, 457  
     named command line option, 491  
     nsupdate command line option, 499  
     rndc command line option, 507

## A

-A  
     dnssec-dsfromkey command line option, 431  
     dnssec-keyfromlabel command line option, 436  
     dnssec-keygen command line option, 440  
     dnssec-settime command line option, 444  
     dnssec-signzone command line option, 450  
     host command line option, 454  
     rndc-confgen command line option, 503

-a  
     ddns-confgen command line option, 413  
     delv command line option, 415  
     dnssec-cds command line option, 429  
     dnssec-dsfromkey command line option, 431  
     dnssec-keyfromlabel command line option, 434  
     dnssec-keygen command line option, 438  
     dnssec-signzone command line option, 446  
     host command line option, 454  
     rndc-confgen command line option, 503  
     tsig-keygen command line option, 514

-AA  
     dnssec-signzone command line option, 450

acl\_name, **88**

address\_match\_element, **87**

address\_match\_list, **88**

addzone  
     rndc command line option, 507

Algorithm, **379**

algorithm  
     nsec3hash command line option, 495

arpaname  
     manual page, 413

## B

-b

delv command line option, 415  
 dig command line option, 419  
 dnssec-keygen command line option, 438  
 mdig command line option, 457  
 rndc command line option, 507  
 rndc-confgen command line option, 503

Block, **85**

Bogus, **410**

boolean, **88**

## C

-C

dnssec-dsfromkey command line option, 431  
 dnssec-keyfromlabel command line option, 435  
 dnssec-keygen command line option, 438  
 dnssec-signzone command line option, 446  
 host command line option, 454  
 named command line option, 492  
 named-rrchecker command line option, 468  
 nsupdate command line option, 499

-c

delv command line option, 415  
 dig command line option, 419  
 dnssec-cds command line option, 429  
 dnssec-dsfromkey command line option, 431  
 dnssec-keyfromlabel command line option, 435  
 dnssec-keygen command line option, 438  
 dnssec-signzone command line option, 446  
 dnssec-verify command line option, 451  
 host command line option, 454  
 mdig command line option, 458  
 named command line option, 491  
 named-checkconf command line option, 461  
 named-checkzone command line option, 462  
 named-compilezone command line option, 465  
 rndc command line option, 507  
 rndc-confgen command line option, 503

CH, **30**

class, **30**

Comment, **85**

## D

-D

dnssec-cds command line option, 429  
 dnssec-importkey command line option, 434  
 dnssec-keyfromlabel command line option, 436  
 dnssec-keygen command line option, 440  
 dnssec-settime command line option, 444  
 dnssec-signzone command line option, 446  
 named command line option, 492

named-checkzone command line option, 464  
 named-compilezone command line option, 466

nsupdate command line option, 499

-d

delv command line option, 415  
 dnssec-cds command line option, 429  
 dnssec-keygen command line option, 438  
 dnssec-settime command line option, 445  
 dnssec-signzone command line option, 446  
 host command line option, 454  
 named command line option, 492  
 named-checkzone command line option, 462  
 named-compilezone command line option, 464  
 nsupdate command line option, 499

ddns-confgen

manual page, 413

ddns-confgen command line option

-a, 413

-h, 414

-k, 414

-q, 414

-s, 414

-z, 414

delv

manual page, 414

delv command line option

+all, 417

+cdfldflag, 416

+class, 417

+comments, 417

+crypto, 417

+dnssec, 418

+mtrace, 417

+multiline, 417

+noall, 417

+nocdfldflag, 416

+noclass, 417

+nocomments, 417

+nocrypto, 417

+nodnssec, 418

+nomtrace, 417

+nomultiline, 417

+noroot, 418

+norrcomments, 417

+nortrace, 417

+noshort, 417

+nosplit, 417

+notcp, 418

+notrust, 417

+nottl, 417

+nounknownformat, 418

+novtrace, 417

+noyaml, 418  
 +root, 418  
 +rrcomments, 417  
 +rtrace, 417  
 +short, 417  
 +split, 417  
 +tcp, 418  
 +trust, 417  
 +ttl, 417  
 +unknownformat, 418  
 +vtrace, 417  
 +yaml, 418  
 -4, 416  
 -6, 416  
 -a, 415  
 -b, 415  
 -c, 415  
 -d, 415  
 -h, 415  
 -i, 416  
 -m, 416  
 name, 415  
 -p, 416  
 -q, 416  
 server, 415  
 -t, 416  
 type, 415  
 -v, 416  
 -x, 416  
 delzone  
     rndc command line option, 508  
 dig  
     manual page, 418  
 dig command line option  
     +aaflag, 421  
     +aaonly, 421  
     +additional, 421  
     +adflag, 421  
     +all, 421  
     +answer, 421  
     +authority, 421  
     +badcookie, 421  
     +besteffort, 421  
     +bufsize, 421  
     +cd, 421  
     +cdfld, 421  
     +class, 421  
     +cmd, 421  
     +co, 422  
     +coflag, 422  
     +comments, 422  
     +cookie, 422  
     +crypto, 422  
     +defname, 422  
     +dns64prefix, 422  
     +dnssec, 422  
     +do, 422  
     +domain, 422  
     +dscp, 422  
     +edns, 422  
     +ednsflags, 422  
     +ednsnegotiation, 422  
     +ednsopt, 422  
     +expire, 423  
     +fail, 423  
     +fuzztime, 423  
     +header-only, 423  
     +http-plain, 423  
     +http-plain-get, 423  
     +http-plain-post, 423  
     +https, 423  
     +https-get, 423  
     +https-post, 423  
     +identify, 423  
     +idnin, 423  
     +idnout, 423  
     +ignore, 424  
     +keepalive, 424  
     +keepopen, 424  
     +multiline, 424  
     +ndots, 424  
     +noaaflag, 421  
     +noaaonly, 421  
     +noadditional, 421  
     +noadflag, 421  
     +noall, 421  
     +noanswer, 421  
     +noauthority, 421  
     +nobadcookie, 421  
     +nobesteffort, 421  
     +nocdflag, 421  
     +noclass, 421  
     +nocmd, 421  
     +noco, 422  
     +nocoflag, 422  
     +nocomments, 422  
     +nocookie, 422  
     +nocrypto, 422  
     +nodefname, 422  
     +nodns64prefix, 422  
     +nodnssec, 422  
     +nodo, 422  
     +noedns, 422  
     +noednsflags, 422  
     +noednsnegotiation, 422  
     +noednsopt, 422  
     +noexpire, 423  
     +nofail, 423

- +nofuzztime, 423
- +noheader-only, 423
- +nohttp-plain, 423
- +nohttp-plain-get, 423
- +nohttp-plain-post, 423
- +nohttps, 423
- +nohttps-get, 423
- +nohttps-post, 423
- +noidentify, 423
- +noidnin, 423
- +noidnout, 423
- +noignore, 424
- +nokeepalive, 424
- +nokeepopen, 424
- +nomultiline, 424
- +nonsid, 424
- +nonssearch, 424
- +noonesoa, 424
- +noopcode, 424
- +noqr, 424
- +noquestion, 424
- +norafLAG, 425
- +nordflag, 425
- +norecurse, 425
- +norrcomments, 425
- +nosearch, 425
- +noshort, 425
- +noshowbadcookie, 425
- +noshowsearch, 425
- +nosigchase, 425
- +nostats, 425
- +nosubnet, 425
- +notcflag, 426
- +notcp, 426
- +notls, 426
- +notls-ca, 426
- +notls-certfile, 426
- +notls-hostname, 426
- +notls-keyfile, 426
- +notopdown, 426
- +notrace, 426
- +nottlid, 426
- +nottlunits, 426
- +nouknownformat, 427
- +novc, 427
- +noyaml, 427
- +nozflag, 427
- +nsid, 424
- +nssearch, 424
- +onesoa, 424
- +opcode, 424
- +padding, 424
- +qid, 424
- +qr, 424

- +question, 424
- +raflag, 425
- +rdflag, 425
- +recurse, 425
- +retry, 425
- +rrcomments, 425
- +search, 425
- +short, 425
- +showbadcookie, 425
- +showsearch, 425
- +sigchase, 425
- +split, 425
- +stats, 425
- +subnet, 425
- +tcflag, 426
- +tcp, 426
- +timeout, 426
- +tls, 426
- +tls-ca, 426
- +tls-certfile, 426
- +tls-hostname, 426
- +tls-keyfile, 426
- +topdown, 426
- +trace, 426
- +tries, 426
- +trusted-key, 426
- +ttlid, 426
- +ttlunits, 426
- +unknownformat, 427
- +vc, 427
- +yaml, 427
- +zflag, 427
- 4, 419
- 6, 419
- b, 419
- c, 419
- f, 419
- h, 419
- k, 420
- m, 420
- name, 419
- p, 420
- q, 420
- r, 420
- server, 419
- t, 420
- type, 419
- u, 420
- v, 420
- x, 420
- y, 420
- dnssec
  - rndc command line option, 508
- dnssec-cds

manual page, 428  
 dnssec-cds command line option  
   -a, 429  
   -c, 429  
   -D, 429  
   -d, 429  
   -f, 429  
   -i, 429  
   -s, 429  
   -T, 429  
   -u, 430  
   -v, 430  
 dnssec-dsfromkey  
   manual page, 430  
 dnssec-dsfromkey command line option  
   -1, 431  
   -2, 431  
   -A, 431  
   -a, 431  
   -C, 431  
   -c, 431  
   -f, 431  
   -h, 432  
   -K, 432  
   -s, 432  
   -T, 432  
   -V, 432  
   -v, 432  
 dnssec-importkey  
   manual page, 432  
 dnssec-importkey command line option  
   -D, 434  
   -f, 433  
   -h, 433  
   -K, 433  
   -L, 433  
   -P, 433  
   -V, 433  
   -v, 433  
 dnssec-importkey--D command line option  
   sync, 434  
 dnssec-importkey--P command line option  
   sync, 434  
 dnssec-keyfromlabel  
   manual page, 434  
 dnssec-keyfromlabel command line option  
   -3, 434  
   -A, 436  
   -a, 434  
   -C, 435  
   -c, 435  
   -D, 436  
   -E, 435  
   -f, 435  
   -G, 435  
   -h, 435  
   -I, 436  
   -i, 437  
   -K, 435  
   -k, 435  
   -L, 435  
   -l, 435  
   -n, 435  
   -P, 436  
   -p, 435  
   -R, 436  
   -S, 435  
   -t, 436  
   -v, 436  
   -y, 436  
 dnssec-keyfromlabel--D command line option  
   sync, 437  
 dnssec-keyfromlabel--P command line option  
   sync, 436  
 dnssec-keygen  
   manual page, 437  
 dnssec-keygen command line option  
   -3, 438  
   -A, 440  
   -a, 438  
   -b, 438  
   -C, 438  
   -c, 438  
   -D, 440  
   -d, 438  
   -E, 438  
   -f, 438  
   -G, 438  
   -g, 439  
   -h, 439  
   -I, 440  
   -i, 440  
   -K, 439  
   -k, 439  
   -L, 439  
   -l, 439  
   -n, 439  
   -P, 440  
   -p, 439  
   -q, 439  
   -R, 440  
   -S, 439  
   -s, 439  
   -T, 439  
   -t, 440  
   -V, 440

-v, 440  
 dnssec-keygen--D command line option  
     sync, 440  
 dnssec-keygen--P command line option  
     sync, 440  
 dnssec-revoke  
     manual page, 441  
 dnssec-revoke command line option  
     -E, 442  
     -f, 442  
     -h, 442  
     -K, 442  
     -R, 442  
     -r, 442  
     -V, 442  
     -v, 442  
 dnssec-settime  
     manual page, 442  
 dnssec-settime command line option  
     -A, 444  
     -D, 444  
     -d, 445  
     -E, 443  
     -f, 443  
     -g, 445  
     -h, 443  
     -I, 444  
     -i, 444  
     -K, 443  
     -k, 445  
     -L, 443  
     -P, 444  
     -p, 445  
     -R, 444  
     -r, 445  
     -S, 444  
     -s, 445  
     -u, 445  
     -V, 443  
     -v, 443  
     -z, 445  
 dnssec-settime--D command line option  
     ds, 444  
     sync, 444  
 dnssec-settime--P command line option  
     ds, 444  
     sync, 444  
 dnssec-signzone  
     manual page, 445  
 dnssec-signzone command line option  
     -3, 450  
     -A, 450  
     -a, 446  
     -AA, 450  
     -C, 446  
     -c, 446  
     -D, 446  
     -d, 446  
     -E, 446  
     -e, 447  
     -f, 447  
     -g, 446  
     -H, 450  
     -h, 447  
     -I, 447  
     -i, 447  
     -j, 447  
     -K, 446  
     -k, 446  
     key, 450  
     -L, 448  
     -M, 446  
     -N, 448  
     -n, 448  
     -O, 448  
     -o, 448  
     -P, 448  
     -Q, 448  
     -q, 448  
     -R, 448  
     -S, 449  
     -s, 446  
     -T, 449  
     -t, 449  
     -u, 449  
     -V, 447  
     -v, 449  
     -X, 447  
     -x, 449  
     -z, 449  
     zonefile, 450  
 dnssec-verify  
     manual page, 451  
 dnssec-verify command line option  
     -c, 451  
     -E, 451  
     -I, 451  
     -o, 451  
     -q, 452  
     -V, 451  
     -v, 451  
     -x, 452  
     -z, 452  
     zonefile, 452  
 dnstap  
     rndc command line option, 508  
 dnstap-read  
     manual page, 452

dnstap-read command line option  
 -m, 452  
 -p, 452  
 -x, 452  
 -y, 452  
 domain  
   nsec3hash command line option, 495  
 domain\_name, 88  
 ds  
   dnssec-settime--D command line option, 444  
   dnssec-settime--P command line option, 444  
 dumpdb  
   rndc command line option, 508  
 duration, 89

## E

-E  
   dnssec-keyfromlabel command line option, 435  
   dnssec-keygen command line option, 438  
   dnssec-revoke command line option, 442  
   dnssec-settime command line option, 443  
   dnssec-signzone command line option, 446  
   dnssec-verify command line option, 451  
   named command line option, 492  
 -e  
   dnssec-signzone command line option, 447

## F

-F  
   named-checkzone command line option, 463  
   named-compilezone command line option, 465  
 -f  
   dig command line option, 419  
   dnssec-cds command line option, 429  
   dnssec-dsfromkey command line option, 431  
   dnssec-importkey command line option, 433  
   dnssec-keyfromlabel command line option, 435  
   dnssec-keygen command line option, 438  
   dnssec-revoke command line option, 442  
   dnssec-settime command line option, 443  
   dnssec-signzone command line option, 447  
   mdig command line option, 457  
   named command line option, 492  
   named-checkzone command line option, 462  
   named-compilezone command line option, 465  
 filename  
   named-checkconf command line option, 461  
   named-checkzone command line option, 464

named-compilezone command line option, 466  
   named-nzd2nzf command line option, 468  
 filter-aaaa  
   manual page, 453  
 fixedpoint, 89  
 flags  
   nsec3hash command line option, 495  
 flush  
   rndc command line option, 508  
 flushname  
   rndc command line option, 508  
 flushtree  
   rndc command line option, 509  
 freeze  
   rndc command line option, 509

## G

-G  
   dnssec-keyfromlabel command line option, 435  
   dnssec-keygen command line option, 438  
 -g  
   dnssec-keygen command line option, 439  
   dnssec-settime command line option, 445  
   dnssec-signzone command line option, 446  
   named command line option, 492  
   nsupdate command line option, 499  
 GitLab  
   [GL #4], 559  
   [GL #54], 557  
   [GL #75], 577  
   [GL #385], 557  
   [GL #481], 557  
   [GL #497], 538  
   [GL #828], 559  
   [GL #1086], 558  
   [GL #1132], 557  
   [GL #1138], 557  
   [GL #1144], 556, 557  
   [GL #1154], 557  
   [GL #1181], 542  
   [GL #1265], 558  
   [GL #1316], 558  
   [GL #1532], 559  
   [GL #1611], 552  
   [GL #1641], 556  
   [GL #1657], 557  
   [GL #1683], 559  
   [GL #1712], 559  
   [GL #1724], 559  
   [GL #1759], 556  
   [GL #1793], 535, 575  
   [GL #1816], 557

|                 |                 |
|-----------------|-----------------|
| [GL #1836], 557 | [GL #3141], 555 |
| [GL #1840], 556 | [GL #3142], 554 |
| [GL #1851], 557 | [GL #3145], 554 |
| [GL #1897], 555 | [GL #3147], 555 |
| [GL #1933], 558 | [GL #3149], 555 |
| [GL #1944], 559 | [GL #3152], 552 |
| [GL #2054], 559 | [GL #3157], 555 |
| [GL #2094], 568 | [GL #3158], 554 |
| [GL #2140], 558 | [GL #3163], 553 |
| [GL #2146], 558 | [GL #3178], 547 |
| [GL #2183], 559 | [GL #3183], 549 |
| [GL #2249], 558 | [GL #3184], 554 |
| [GL #2267], 553 | [GL #3190], 545 |
| [GL #2313], 557 | [GL #3200], 554 |
| [GL #2392], 556 | [GL #3205], 554 |
| [GL #2398], 559 | [GL #3212], 547 |
| [GL #2433], 559 | [GL #3216], 553 |
| [GL #2472], 556 | [GL #3221], 553 |
| [GL #2478], 556 | [GL #3222], 553 |
| [GL #2506], 552 | [GL #3223], 553 |
| [GL #2690], 557 | [GL #3224], 553 |
| [GL #2691], 557 | [GL #3225], 553 |
| [GL #2723], 556 | [GL #3242], 554 |
| [GL #2742], 559 | [GL #3244], 554 |
| [GL #2776], 556 | [GL #3247], 549 |
| [GL #2794], 556 | [GL #3248], 554 |
| [GL #2795], 556 | [GL #3249], 554 |
| [GL #2796], 556 | [GL #3302], 553 |
| [GL #2809], 556 | [GL #3323], 538 |
| [GL #2814], 557 | [GL #3325], 543 |
| [GL #2843], 557 | [GL #3327], 553 |
| [GL #2871], 558 | [GL #3380], 553 |
| [GL #2882], 557 | [GL #3381], 551 |
| [GL #2895], 549 | [GL #3386], 548 |
| [GL #2918], 552 | [GL #3394], 550 |
| [GL #2926], 558 | [GL #3395], 552 |
| [GL #2931], 554 | [GL #3400], 552 |
| [GL #2941], 559 | [GL #3402], 552 |
| [GL #2950], 554 | [GL #3403], 538 |
| [GL #2956], 558 | [GL #3405], 538 |
| [GL #2982], 551 | [GL #3415], 552 |
| [GL #3020], 554 | [GL #3438], 551 |
| [GL #3048], 559 | [GL #3439], 551 |
| [GL #3057], 557 | [GL #3459], 551 |
| [GL #3060], 555 | [GL #3461], 551 |
| [GL #3082], 555 | [GL #3462], 552 |
| [GL #3093], 558 | [GL #3469], 551 |
| [GL #3111], 555 | [GL #3472], 538 |
| [GL #3112], 554 | [GL #3485], 551 |
| [GL #3125], 555 | [GL #3486], 551 |
| [GL #3128], 554 | [GL #3487], 551 |
| [GL #3129], 555 | [GL #3491], 551 |
| [GL #3132], 555 | [GL #3493], 550 |
| [GL #3137], 555 | [GL #3512], 550 |

[GL #3516], 537, 578  
 [GL #3517], 551  
 [GL #3523], 547  
 [GL #3541], 550  
 [GL #3542], 550  
 [GL #3544], 550  
 [GL #3557], 550  
 [GL #3563], 549  
 [GL #3578], 550  
 [GL #3584], 549  
 [GL #3587], 550  
 [GL #3591], 549  
 [GL #3598], 549  
 [GL #3603], 549  
 [GL #3619], 547  
 [GL #3622], 547  
 [GL #3627], 549  
 [GL #3636], 547  
 [GL #3637], 548  
 [GL #3638], 549  
 [GL #3667], 548  
 [GL #3668], 543  
 [GL #3670], 548  
 [GL #3673], 546  
 [GL #3676], 548  
 [GL #3678], 548  
 [GL #3683], 548  
 [GL #3693], 548  
 [GL #3694], 548  
 [GL #3700], 543  
 [GL #3707], 549  
 [GL #3721], 549  
 [GL #3725], 548  
 [GL #3727], 548  
 [GL #3739], 548  
 [GL #3743], 548  
 [GL #3744], 547  
 [GL #3752], 548  
 [GL #3772], 547  
 [GL #3773], 547  
 [GL #3781], 546  
 [GL #3783], 547  
 [GL #3795], 546  
 [GL #3801], 546  
 [GL #3827], 547  
 [GL #3840], 546  
 [GL #3867], 545  
 [GL #3881], 546  
 [GL #3885], 532, 570  
 [GL #3905], 544  
 [GL #3911], 546  
 [GL #3949], 531, 567  
 [GL #3950], 544  
 [GL #3953], 545  
 [GL #3955], 545  
 [GL #3968], 545  
 [GL #3978], 544  
 [GL #3981], 545  
 [GL #3991], 545  
 [GL #3997], 545  
 [GL #4002], 545  
 [GL #4004], 544  
 [GL #4005], 545  
 [GL #4027], 545  
 [GL #4032], 543  
 [GL #4038], 542, 544  
 [GL #4046], 545  
 [GL #4049], 543  
 [GL #4055], 544  
 [GL #4071], 544  
 [GL #4074], 544  
 [GL #4089], 544  
 [GL #4101], 541  
 [GL #4118], 577  
 [GL #4124], 542  
 [GL #4125], 542  
 [GL #4132], 543  
 [GL #4136], 543  
 [GL #4152], 542  
 [GL #4154], 543  
 [GL #4159], 542  
 [GL #4171], 543  
 [GL #4200], 543  
 [GL #4204], 529, 564  
 [GL #4215], 543  
 [GL #4234], 540  
 [GL #4242], 542  
 [GL #4255], 543  
 [GL #4261], 573  
 [GL #4263], 542  
 [GL #4278], 542  
 [GL #4280], 542  
 [GL #4281], 540  
 [GL #4334], 540  
 [GL #4350], 541  
 [GL #4355], 541  
 [GL #4386], 541  
 [GL #4387], 541  
 [GL #4405], 541  
 [GL #4421], 541  
 [GL #4424], 540  
 [GL #4425], 539  
 [GL #4449], 537, 579  
 [GL #4459], 540  
 [GL #4460], 536  
 [GL #4467], 540  
 [GL #4473], 538  
 [GL #4480], 538

[GL #4481], 538  
[GL #4485], 571  
[GL #4487], 540  
[GL #4507], 538  
[GL #4518], 539  
[GL #4528], 539  
[GL #4548], 538  
[GL #4552], 539  
[GL #4554], 539  
[GL #4579], 576  
[GL #4580], 539  
[GL #4586], 539  
[GL #4591], 540  
[GL #4595], 540  
[GL #4596], 539  
[GL #4621], 540  
[GL #4624], 539  
[GL #4661], 538  
[GL #4677], 537, 579  
[GL #4708], 538  
[GL #4719], 538  
[GL #4731], 536, 576  
[GL #4733], 537, 577  
[GL #4736], 538  
[GL #4741], 537, 577  
[GL #4742], 538  
[GL #4766], 537, 578  
[GL #4775], 537, 579  
[GL #4784], 537, 578  
[GL #4795], 533, 571  
[GL #4796], 537, 579  
[GL #4797], 576  
[GL #4798], 578  
[GL #4799], 579  
[GL #4806], 537, 579  
[GL #4831], 578  
[GL #4833], 578  
[GL #4834], 578  
[GL #4845], 576  
[GL #4850], 535, 575  
[GL #4852], 576  
[GL #4853], 576  
[GL #4855], 536, 576  
[GL #4865], 534, 572  
[GL #4878], 536, 577  
[GL #4880], 577  
[GL #4884], 536, 576  
[GL #4886], 577  
[GL #4895], 535, 575  
[GL #4896], 534, 572  
[GL #4910], 534, 571  
[GL #4921], 534, 571  
[GL #4922], 535, 574  
[GL #4928], 535, 575  
[GL #4930], 536, 575  
[GL #4933], 567  
[GL #4936], 536, 575  
[GL #4938], 572  
[GL #4939], 575  
[GL #4947], 535, 574  
[GL #4950], 535, 574  
[GL #4980], 534, 571  
[GL #4993], 535, 574  
[GL #5006], 534, 572  
[GL #5008], 535, 574  
[GL #5018], 568  
[GL #5034], 533, 571  
[GL #5066], 531, 532, 567, 568  
[GL #5070], 534, 572  
[GL #5079], 568  
[GL #5083], 533, 571  
[GL #5084], 534, 572  
[GL #5094], 533, 570  
[GL #5098], 533, 570  
[GL #5121], 572  
[GL #5127], 533, 570  
[GL #5130], 533, 570  
[GL #5132], 568  
[GL #5138], 568  
[GL #5146], 532, 569  
[GL #5150], 532, 569  
[GL #5155], 570  
[GL #5185], 532, 569  
[GL #5193], 531, 567  
[GL #5197], 569  
[GL #5201], 532, 567  
[GL #5219], 568  
[GL #5240], 531, 568  
[GL #5246], 531, 566  
[GL #5247], 531, 567  
[GL #5280], 567  
[GL #5294], 529, 564  
[GL #5315], 531, 566  
[GL #5319], 531, 566  
[GL #5343], 529, 563  
[GL #5357], 565  
[GL #5358], 530  
[GL #5383], 531, 566  
[GL #5414], 529, 564  
[GL #5440], 530, 565  
[GL #5444], 529, 564  
[GL #5467], 564  
[GL #5484], 529, 564  
[GL #5491], 565  
[GL #5502], 529, 565  
[GL #5614], 527, 562  
[GL #5616], 528, 562  
[GL #5622], 528, 563

[GL #5639], 528, 563  
 [GL #5659], 528, 562  
 [GL #5671], 528, 563  
 [GL #5679], 528, 562  
 [GL #5690], 527, 562  
 [GL #5694], 562  
 [GL #5699], 562  
 [GL #5708], 527, 561  
 [GL #5710], 527, 562  
 [GL #5711], 527, 562  
 [GL #5749], 561  
 [GL #5751], 527, 561  
 [GL !4045], 558  
 [GL !9161], 537, 579  
 [GL !9181], 577  
 [GL !9192], 537, 579  
 [GL !9198], 577  
 [GL !9200], 579  
 [GL !9204], 537, 579  
 [GL !9210], 537, 579  
 [GL !9214], 537, 579  
 [GL !9216], 537, 578  
 [GL !9218], 537, 578  
 [GL !9224], 578  
 [GL !9230], 578  
 [GL !9251], 537, 578  
 [GL !9257], 578  
 [GL !9263], 577  
 [GL !9268], 578  
 [GL !9278], 578  
 [GL !9279], 578  
 [GL !9283], 537, 577  
 [GL !9329], 576  
 [GL !9340], 576  
 [GL !9342], 576  
 [GL !9344], 576  
 [GL !9348], 576  
 [GL !9373], 576  
 [GL !9386], 576  
 [GL !9388], 577  
 [GL !9394], 577  
 [GL !9409], 577  
 [GL !9419], 577  
 [GL !9443], 576  
 [GL !9472], 575  
 [GL !9487], 575  
 [GL !9501], 575  
 [GL !9503], 575  
 [GL !9505], 575  
 [GL !9512], 575  
 [GL !9555], 574  
 [GL !9568], 575  
 [GL !9572], 575  
 [GL !9584], 575  
 [GL !9605], 574  
 [GL !9607], 569  
 [GL !9614], 574  
 [GL !9623], 573  
 [GL !9632], 574  
 [GL !9645], 574  
 [GL !9667], 574  
 [GL !9689], 573  
 [GL !9700], 572  
 [GL !9735], 573  
 [GL !9747], 572  
 [GL !9751], 573  
 [GL !9768], 574  
 [GL !9770], 574  
 [GL !9772], 573  
 [GL !9778], 572  
 [GL !9796], 574  
 [GL !9821], 572  
 [GL !9835], 571  
 [GL !9841], 572  
 [GL !9847], 571  
 [GL !9854], 571  
 [GL !9864], 571  
 [GL !9867], 571  
 [GL !9878], 572  
 [GL !9937], 572  
 [GL !9953], 569  
 [GL !9959], 569  
 [GL !9960], 570  
 [GL !9961], 570  
 [GL !9965], 570  
 [GL !9976], 570  
 [GL !9980], 570  
 [GL !10025], 570  
 [GL !10036], 570  
 [GL !10051], 570  
 [GL !10060], 570  
 [GL !10062], 569  
 [GL !10086], 568  
 [GL !10101], 569  
 [GL !10106], 568  
 [GL !10128], 569  
 [GL !10135], 568  
 [GL !10143], 569  
 [GL !10145], 569  
 [GL !10159], 569  
 [GL !10171], 568  
 [GL !10193], 569  
 [GL !10203], 568  
 [GL !10208], 568  
 [GL !10213], 569  
 [GL !10219], 568  
 [GL !10260], 567  
 [GL !10265], 567

[GL !10288], 567  
 [GL !10294], 567  
 [GL !10316], 568  
 [GL !10330], 567  
 [GL !10390], 567  
 [GL !10499], 566  
 [GL !10579], 566  
 [GL !10599], 566  
 [GL !10637], 530  
 [GL !10680], 566  
 [GL !10708], 566  
 [GL !10719], 565  
 [GL !10739], 565  
 [GL !10758], 530, 566  
 [GL !10783], 564  
 [GL !10816], 566  
 [GL !10821], 565  
 [GL !10833], 564  
 [GL !10865], 564  
 [GL !10899], 564  
 [GL !10914], 565  
 [GL !10925], 564  
 [GL !10931], 565  
 [GL !10933], 564  
 [GL !10957], 565  
 [GL !11080], 563  
 [GL !11211], 563  
 [GL !11238], 563  
 [GL !11256], 563  
 [GL !11341], 563  
 [GL !11368], 562  
 [GL !11402], 562  
 [GL !11438], 562  
 [GL !11464], 562  
 [GL !11470], 562  
 [GL !11484], 562  
 [GL !11493], 562  
 [GL !11584], 561  
 [GL !11595], 561

**H**

-H dnssec-signzone command line option, 450  
 -h  
 ddns-confgen command line option, 414  
 delv command line option, 415  
 dig command line option, 419  
 dnssec-dsfromkey command line option, 432  
 dnssec-importkey command line option, 433  
 dnssec-keyfromlabel command line option, 435  
 dnssec-keygen command line option, 439  
 dnssec-revoke command line option, 442  
 dnssec-settime command line option, 443

dnssec-signzone command line option, 447  
 mdig command line option, 457  
 named-checkconf command line option, 461  
 named-checkzone command line option, 462  
 named-compilezone command line option, 464  
 named-rrchecker command line option, 468  
 rndc-confgen command line option, 504  
 tsig-keygen command line option, 514  
 halt  
 rndc command line option, 509  
 host  
 manual page, 454  
 host command line option  
 -4, 454  
 -6, 454  
 -A, 454  
 -a, 454  
 -C, 454  
 -c, 454  
 -d, 454  
 -l, 454  
 -m, 455  
 -N, 454  
 -p, 455  
 -R, 455  
 -r, 455  
 -s, 455  
 -T, 455  
 -t, 455  
 -U, 455  
 -V, 455  
 -v, 455  
 -W, 455  
 -w, 455

**HS, 30**

**I**

-I  
 dnssec-keyfromlabel command line option, 436  
 dnssec-keygen command line option, 440  
 dnssec-settime command line option, 444  
 dnssec-signzone command line option, 447  
 dnssec-verify command line option, 451  
 -i  
 delv command line option, 416  
 dnssec-cds command line option, 429  
 dnssec-keyfromlabel command line option, 437  
 dnssec-keygen command line option, 440  
 dnssec-settime command line option, 444  
 dnssec-signzone command line option, 447  
 named-checkconf command line option, 461

- named-checkzone command line option, 462
- named-compilezone command line option, 465
- nsupdate command line option, 499
- IN, 30
- Indeterminate, 410
- Insecure, 409
- integer, 89
- ip\_address, 89
- ipv4\_address, 89
- ipv6\_address, 89
- ISC Knowledgebase
  - (CVE-2021-25220), 554
  - (CVE-2022-0396), 554
  - (CVE-2022-0635), 554
  - (CVE-2022-0667), 555
  - (CVE-2022-1183), 553
  - (CVE-2022-2795), 550
  - (CVE-2022-2881), 550
  - (CVE-2022-2906), 551
  - (CVE-2022-3080), 551
  - (CVE-2022-3094), 547
  - (CVE-2022-3736), 547
  - (CVE-2022-3924), 547
  - (CVE-2022-38178), 551
  - (CVE-2023-2828), 544
  - (CVE-2023-2911), 544
  - (CVE-2023-3341), 542
  - (CVE-2023-4236), 542
  - (CVE-2023-4408), 540
  - (CVE-2023-5517), 540
  - (CVE-2023-5679), 540
  - (CVE-2023-50387), 540
  - (CVE-2023-50868), 540
  - (CVE-2024-0760), 538
  - (CVE-2024-1737), 538
  - (CVE-2024-1975), 538
  - (CVE-2024-4076), 538
  - (CVE-2024-11187), 533
  - (CVE-2024-12705), 533
  - (CVE-2025-8677), 528
  - (CVE-2025-13878), 528
  - (CVE-2025-40778), 529
  - (CVE-2025-40780), 529
  - (CVE-2026-1519), 527
- Iterations, 380
- iterations
  - nsec3hash command line option, 495
- J**
- J
  - named-checkzone command line option, 462
  - named-compilezone command line option, 465
- named-checkzone command line option, 462
- named-checkconf command line option, 461
- named-compilezone command line option, 465
- named-checkzone command line option, 462
- named-compilezone command line option, 465
- K**
- K
  - dnssec-dsfromkey command line option, 432
  - dnssec-importkey command line option, 433
  - dnssec-keyfromlabel command line option, 435
  - dnssec-keygen command line option, 439
  - dnssec-revoke command line option, 442
  - dnssec-settime command line option, 443
  - dnssec-signzone command line option, 446
- k
  - ddns-confgen command line option, 414
  - dig command line option, 420
  - dnssec-keyfromlabel command line option, 435
  - dnssec-keygen command line option, 439
  - dnssec-settime command line option, 445
  - dnssec-signzone command line option, 446
  - named-checkzone command line option, 463
  - named-compilezone command line option, 465
  - nsupdate command line option, 499
  - rndc command line option, 507
  - rndc-confgen command line option, 504
- key
  - dnssec-signzone command line option, 450
- L**
- L
  - dnssec-importkey command line option, 433
  - dnssec-keyfromlabel command line option, 435
  - dnssec-keygen command line option, 439
  - dnssec-settime command line option, 443
  - dnssec-signzone command line option, 448
  - named command line option, 492
  - named-checkzone command line option, 463
  - named-compilezone command line option, 465
  - nsupdate command line option, 499
- l
  - dnssec-keyfromlabel command line option, 435
  - dnssec-keygen command line option, 439
  - host command line option, 454
  - named-checkconf command line option, 461
  - named-checkzone command line option, 463

- named-compilezone command line option, 465
- nsupdate command line option, 499
- level
  - rndc-trace command line option, 513
- loadkeys
  - rndc command line option, 509

## M

- M
  - dnssec-signzone command line option, 446
  - named command line option, 492
  - named-checkzone command line option, 463
  - named-compilezone command line option, 466
- m
  - delv command line option, 416
  - dig command line option, 420
  - dnstap-read command line option, 452
  - host command line option, 455
  - mdig command line option, 457
  - named command line option, 492
  - named-checkzone command line option, 463
  - named-compilezone command line option, 466
- managed-keys
  - rndc command line option, 509
- manual page
  - arpaname, 413
  - ddns-confgen, 413
  - delv, 414
  - dig, 418
  - dnssec-cds, 428
  - dnssec-dsfromkey, 430
  - dnssec-importkey, 432
  - dnssec-keyfromlabel, 434
  - dnssec-keygen, 437
  - dnssec-revoke, 441
  - dnssec-settime, 442
  - dnssec-signzone, 445
  - dnssec-verify, 451
  - dnstap-read, 452
  - filter-aaaa, 453
  - host, 454
  - mdig, 456
  - named, 491
  - named-checkconf, 460
  - named-checkzone, 461
  - named-compilezone, 464
  - named.conf, 472
  - named-journalprint, 467
  - named-nzd2nzf, 467
  - named-rrchecker, 468
  - nsec3hash, 494

- nslookup, 495
- nsupdate, 498
- rndc, 506
- rndc.conf, 504
- rndc-confgen, 503
- tsig-keygen, 514
- mdig
  - manual page, 456
- mdig command line option
  - +aaflag, 459
  - +aaonly, 459
  - +additional, 457
  - +adflag, 459
  - +all, 457
  - +answer, 457
  - +authority, 457
  - +besteffort, 457
  - +bufsize, 459
  - +burst, 457
  - +cdflag, 459
  - +cl, 457
  - +comments, 457
  - +continue, 458
  - +cookie, 459
  - +crypto, 458
  - +dnssec, 459
  - +dscp, 458
  - +edns, 459
  - +ednsflags, 459
  - +ednsopt, 459
  - +expire, 459
  - +multiline, 458
  - +noaaflag, 459
  - +noaaonly, 459
  - +noadditional, 457
  - +noadflag, 459
  - +noall, 457
  - +noanswer, 457
  - +noauthority, 457
  - +nobesteffort, 457
  - +nocdf, 459
  - +nocl, 457
  - +nocomments, 457
  - +nocontinue, 458
  - +nocookie, 459
  - +nocrypto, 458
  - +nodnssec, 459
  - +noedns, 459
  - +noednsflags, 459
  - +noednsopt, 459
  - +noexpire, 459
  - +nomultiline, 458
  - +nonsid, 459
  - +noquestion, 458

- +norecurse, 460
- +norrcomments, 458
- +noshort, 458
- +nosubnet, 460
- +notcp, 458
- +nottlid, 458
- +nottlunits, 458
- +nunknownformat, 460
- +novc, 458
- +noyaml, 460
- +nozflag, 460
- +nsid, 459
- +question, 458
- +recurse, 460
- +retry, 460
- +rrcomments, 458
- +short, 458
- +split, 458
- +subnet, 460
- +tcp, 458
- +timeout, 460
- +tries, 460
- +ttlid, 458
- +ttlunits, 458
- +udptimeout, 460
- +unknownformat, 460
- +vc, 458
- +yaml, 460
- +zflag, 460
- 4, 457
- 6, 457
- b, 457
- c, 458
- f, 457
- h, 457
- m, 457
- p, 457
- t, 458
- v, 457
- x, 459
- modzone
  - rndc command line option, 509
- N**
- N
  - dnssec-signzone command line option, 448
  - host command line option, 454
- n
  - dnssec-keyfromlabel command line option, 435
  - dnssec-keygen command line option, 439
  - dnssec-signzone command line option, 448
  - named command line option, 492
  - named-checkzone command line option, 463
  - named-compilezone command line option, 466
  - name
    - delv command line option, 415
    - dig command line option, 419
  - named
    - manual page, 491
  - named command line option
    - 4, 491
    - 6, 491
    - C, 492
    - c, 491
    - D, 492
    - d, 492
    - E, 492
    - f, 492
    - g, 492
    - L, 492
    - M, 492
    - m, 492
    - n, 492
    - p, 492
    - s, 493
    - s, 493
    - t, 493
    - U, 493
    - u, 493
    - V, 494
    - v, 494
    - X, 494
  - named-checkconf
    - manual page, 460
  - named-checkconf command line option
    - c, 461
    - filename, 461
    - h, 461
    - i, 461
    - j, 461
    - l, 461
    - p, 461
    - t, 461
    - v, 461
    - x, 461
    - z, 461
  - named-checkzone
    - manual page, 461
  - named-checkzone command line option
    - c, 462
    - D, 464
    - d, 462
    - F, 463
    - f, 462
    - filename, 464
    - h, 462

- i, 462
- J, 462
- j, 462
- k, 463
- L, 463
- l, 463
- M, 463
- m, 463
- n, 463
- o, 463
- q, 462
- r, 463
- S, 463
- s, 463
- T, 463
- t, 463
- v, 462
- W, 464
- w, 464
- zonename, 464
- named-compilezone
  - manual page, 464
- named-compilezone command line option
  - c, 465
  - D, 466
  - d, 464
  - F, 465
  - f, 465
  - filename, 466
  - h, 464
  - i, 465
  - J, 465
  - j, 465
  - k, 465
  - L, 465
  - l, 465
  - M, 466
  - m, 466
  - n, 466
  - o, 466
  - q, 464
  - r, 466
  - S, 466
  - s, 466
  - T, 466
  - t, 466
  - v, 465
  - W, 466
  - w, 466
  - zonename, 466
- named.conf
  - manual page, 472
- named-journalprint
  - manual page, 467
- named-nzd2nzf
  - manual page, 467
- named-nzd2nzf command line option
  - filename, 468
- named-rrchecker
  - manual page, 468
- named-rrchecker command line option
  - C, 468
  - h, 468
  - o, 468
  - P, 468
  - p, 468
  - T, 468
  - u, 468
- netprefix, **89**
- notify
  - rndc command line option, 510
- notrace
  - rndc command line option, 510
- NSEC3 Hashing Algorithm, **379**
- nsec3hash
  - manual page, 494
- nsec3hash command line option
  - algorithm, 495
  - domain, 495
  - flags, 495
  - iterations, 495
  - salt, 495
- nslookup
  - manual page, 495
- nsupdate
  - manual page, 498
- nsupdate command line option
  - 4, 499
  - 6, 499
  - C, 499
  - D, 499
  - d, 499
  - g, 499
  - i, 499
  - k, 499
  - L, 499
  - l, 499
  - o, 499
  - P, 499
  - p, 499
  - r, 499
  - T, 500
  - t, 499
  - u, 500
  - V, 500
  - v, 500
  - y, 500
- nta

rndc command line option, 510

## O

- O dnssec-signzone command line option, 448
- o dnssec-signzone command line option, 448
- dnssec-verify command line option, 451
- named-checkzone command line option, 463
- named-compilezone command line option, 466
- named-rrchecker command line option, 468
- nsupdate command line option, 499

Opt-out, **380**

owner name, **30**

## P

- P dnssec-importkey command line option, 433
- dnssec-keyfromlabel command line option, 436
- dnssec-keygen command line option, 440
- dnssec-settime command line option, 444
- dnssec-signzone command line option, 448
- named-rrchecker command line option, 468
- nsupdate command line option, 499
- p delv command line option, 416
- dig command line option, 420
- dnssec-keyfromlabel command line option, 435
- dnssec-keygen command line option, 439
- dnssec-settime command line option, 445
- dnstap-read command line option, 452
- host command line option, 455
- mdig command line option, 457
- named command line option, 492
- named-checkconf command line option, 461
- named-rrchecker command line option, 468
- nsupdate command line option, 499
- rndc command line option, 507
- rndc-confgen command line option, 504

percentage, **89**

port, **89**

portrange, **89**

## Q

- Q dnssec-signzone command line option, 448
- q ddns-confgen command line option, 414
- delv command line option, 416
- dig command line option, 420
- dnssec-keygen command line option, 439

- dnssec-signzone command line option, 448
- dnssec-verify command line option, 452
- named-checkzone command line option, 462
- named-compilezone command line option, 464

rndc command line option, 507

rndc-confgen command line option, 504

querylog

rndc command line option, 510

## R

- R dnssec-keyfromlabel command line option, 436

dnssec-keygen command line option, 440

dnssec-revoke command line option, 442

dnssec-settime command line option, 444

dnssec-signzone command line option, 448

host command line option, 455

-r

dig command line option, 420

dnssec-revoke command line option, 442

dnssec-settime command line option, 445

host command line option, 455

named-checkzone command line option, 463

named-compilezone command line option, 466

nsupdate command line option, 499

rndc command line option, 507

RDATA, **30**

reconfig

rndc command line option, 511

recurring

rndc command line option, 511

refresh

rndc command line option, 511

reload

rndc command line option, 511

remote-servers, **90**

retransfer

rndc command line option, 511

RFC

RFC 821, 144

RFC 882, 987

RFC 883, 987

RFC 920, 987

RFC 952, 144

RFC 1033, 491, 494

RFC 1034, 7, 30, 31, 100, 101, 145, 154, 472, 491,

494, 502, 503, 515, 987

RFC 1035, 7, 32, 33, 428, 460, 464, 467, 469, 471,

472, 491, 494, 515, 987

RFC 1035 Section 3.3.14, 470

RFC 1035 Section 5.1, 468, 469, 471

RFC 1101, 519  
RFC 1123, 134, 144, 519  
RFC 1183, 515  
RFC 1521, 515  
RFC 1535, 519  
RFC 1536, 519  
RFC 1706, 515  
RFC 1712, 515  
RFC 1796, 515  
RFC 1876, 515  
RFC 1912, 519  
RFC 1918, 23, 56, 188, 197, 244  
RFC 1982, 448, 515  
RFC 1995, 56, 70, 515  
RFC 1996, 16, 56, 70, 72, 515  
RFC 2104, 503  
RFC 2136, 55, 498, 503, 515  
RFC 2163, 515  
RFC 2181, 516  
RFC 2193, 23  
RFC 2219, 519  
RFC 2230, 516  
RFC 2308, 32, 33, 516  
RFC 2317, 34, 519  
RFC 2535, 435, 437, 439, 498, 502, 503  
RFC 2539, 439, 441, 516  
RFC 2606, 519  
RFC 2671, 205, 265, 299  
RFC 2782, 516  
RFC 2845, 80, 441, 498, 503, 514  
RFC 2874, 519  
RFC 2930, 82, 516  
RFC 2931, 498, 503, 516, 538  
RFC 3007, 55, 503, 516  
RFC 3056, 256  
RFC 3110, 516  
RFC 3123, 66, 516  
RFC 3225, 516  
RFC 3226, 516  
RFC 3339, 89  
RFC 3363, 59, 60, 516, 519  
RFC 3403, 516  
RFC 3492, 516  
RFC 3493, 516  
RFC 3496, 516  
RFC 3548, 39  
RFC 3596, 516  
RFC 3597, 418, 420, 427, 460, 468, 471, 516  
RFC 3645, 498, 516  
RFC 3658, 432  
RFC 3833, 519  
RFC 3901, 519  
RFC 3957, 471, 472  
RFC 3986, 214  
RFC 4025, 516  
RFC 4033, 451, 452, 516  
RFC 4034, 418, 437, 441, 516  
RFC 4035, 409, 418, 516  
RFC 4074, 519  
RFC 4193, 188  
RFC 4255, 516  
RFC 4294, 519  
RFC 4343, 517  
RFC 4398, 517  
RFC 4431, 418, 519  
RFC 4470, 379, 517  
RFC 4509, 432, 517  
RFC 4592, 69, 464, 466, 517  
RFC 4635, 517  
RFC 4701, 517  
RFC 4892, 519  
RFC 4955, 517  
RFC 5001, 517  
RFC 5011, 50, 91, 215, 216, 366, 415, 434, 436, 442, 445, 509, 517  
RFC 5074, 418  
RFC 5155, 403, 418, 495, 517  
RFC 5205, 517  
RFC 5452, 517  
RFC 5625, 519  
RFC 5702, 517  
RFC 5737, 23, 188  
RFC 5891, 517  
RFC 5936, 517  
RFC 5952, 517  
RFC 6052, 125, 517  
RFC 6147, 517  
RFC 6303, 519  
RFC 6598, 23, 188  
RFC 6604, 517  
RFC 6605, 432, 517  
RFC 6672, 517  
RFC 6698, 388, 517  
RFC 6725, 517  
RFC 6742, 517  
RFC 6781, 451, 519  
RFC 6781 Section 4.1.1.1, 448  
RFC 6781 Section 4.1.1.2, 449  
RFC 6840, 518  
RFC 6891, 206, 518, 558  
RFC 7043, 518  
RFC 7050, 518  
RFC 7129, 378, 519  
RFC 7208, 518  
RFC 7314, 518  
RFC 7344, 49, 362, 428, 430, 432, 518  
RFC 7477, 518  
RFC 7512, 437

- RFC 7553, 518
  - RFC 7583, 329, 387, 518
  - RFC 7672, 388
  - RFC 7766, 518
  - RFC 7793, 519
  - RFC 7816, 117
  - RFC 7828, 518
  - RFC 7830, 518
  - RFC 7858, 518
  - RFC 7929, 388, 518
  - RFC 8078, 362, 406, 518
  - RFC 8080, 518
  - RFC 8198, 148, 281, 288, 380, 404, 558
  - RFC 8310, 553
  - RFC 8484, 326, 518
  - RFC 8509, 133, 518
  - RFC 8624, 517, 518
  - RFC 8659, 518
  - RFC 8749, 519
  - RFC 8767, 138, 139
  - RFC 8777, 528
  - RFC 8806, 242
  - RFC 8880, 518
  - RFC 8906, 519
  - RFC 8914, 553, 557
  - RFC 8945, 518
  - RFC 9103, 518, 553, 556
  - RFC 9276, 221, 379381, 450, 519
  - RFC 9432, 63, 519
  - RFC 9460, 471, 519
  - rndc
    - manual page, 506
  - rndc command line option
    - 4, 507
    - 6, 507
    - addzone, 507
    - b, 507
    - c, 507
    - delzone, 508
    - dnssec, 508
    - dnstap, 508
    - dumpdb, 508
    - flush, 508
    - flushname, 508
    - flushtree, 509
    - freeze, 509
    - halt, 509
    - k, 507
    - loadkeys, 509
    - managed-keys, 509
    - modzone, 509
    - notify, 510
    - notrace, 510
    - nta, 510
    - p, 507
    - q, 507
    - querylog, 510
    - r, 507
    - reconfig, 511
    - recurring, 511
    - refresh, 511
    - reload, 511
    - retransfer, 511
    - s, 507
    - scan, 511
    - secroots, 511
    - serve-stale, 511
    - showzone, 512
    - sign, 512
    - signing, 512
    - stats, 512
    - status, 513
    - stop, 513
    - sync, 513
    - tcp-timeouts, 513
    - thaw, 513
    - trace, 513
    - tsig-delete, 513
    - tsig-list, 513
    - v, 507
    - validation, 513
    - y, 507
    - zonestatus, 513
  - rndc.conf
    - manual page, 504
  - rndc-confgen
    - manual page, 503
  - rndc-confgen command line option
    - A, 503
    - a, 503
    - b, 503
    - c, 503
    - h, 504
    - k, 504
    - p, 504
    - q, 504
    - s, 504
    - t, 504
    - u, 504
  - rndc-reload command line option
    - zone, 511
  - rndc-trace command line option
    - level, 513
  - RR TTLs, **32**
  - RR type, **30**
- S**
- S

dnssec-keyfromlabel command line option, 435  
 dnssec-keygen command line option, 439  
 dnssec-settime command line option, 444  
 dnssec-signzone command line option, 449  
 named command line option, 493  
 named-checkzone command line option, 463  
 named-compilezone command line option, 466  
 -s  
 ddns-confgen command line option, 414  
 dnssec-cds command line option, 429  
 dnssec-dsfromkey command line option, 432  
 dnssec-keygen command line option, 439  
 dnssec-settime command line option, 445  
 dnssec-signzone command line option, 446  
 host command line option, 455  
 named command line option, 493  
 named-checkzone command line option, 463  
 named-compilezone command line option, 466  
 rndc command line option, 507  
 rndc-confgen command line option, 504  
 Salt, 380  
 salt  
 nsec3hash command line option, 495  
 scan  
 rndc command line option, 511  
 secroots  
 rndc command line option, 511  
 Secure, 409  
 server  
 delv command line option, 415  
 dig command line option, 419  
 server\_key, 90  
 serve-stale  
 rndc command line option, 511  
 showzone  
 rndc command line option, 512  
 sign  
 rndc command line option, 512  
 signing  
 rndc command line option, 512  
 size, 90  
 sizeval, 90  
 SOA minimum, 32  
 Statement, 85  
 stats  
 rndc command line option, 512  
 status  
 rndc command line option, 513  
 stop  
 rndc command line option, 513  
 sync

dnssec-importkey--D command line option, 434  
 dnssec-importkey--P command line option, 434  
 dnssec-keyfromlabel--D command line option, 437  
 dnssec-keyfromlabel--P command line option, 436  
 dnssec-keygen--D command line option, 440  
 dnssec-keygen--P command line option, 440  
 dnssec-settime--D command line option, 444  
 dnssec-settime--P command line option, 444  
 rndc command line option, 513  
**T**  
 -T  
 dnssec-cds command line option, 429  
 dnssec-dsfromkey command line option, 432  
 dnssec-keygen command line option, 439  
 dnssec-signzone command line option, 449  
 host command line option, 455  
 named-checkzone command line option, 463  
 named-compilezone command line option, 466  
 named-rrchecker command line option, 468  
 nsupdate command line option, 500  
 -t  
 delv command line option, 416  
 dig command line option, 420  
 dnssec-keyfromlabel command line option, 436  
 dnssec-keygen command line option, 440  
 dnssec-signzone command line option, 449  
 host command line option, 455  
 mdig command line option, 458  
 named command line option, 493  
 named-checkconf command line option, 461  
 named-checkzone command line option, 463  
 named-compilezone command line option, 466  
 nsupdate command line option, 499  
 rndc-confgen command line option, 504  
 tcp-timeouts  
 rndc command line option, 513  
 thaw  
 rndc command line option, 513  
 tls\_id, 90  
 trace  
 rndc command line option, 513  
 tsig-delete  
 rndc command line option, 513  
 tsig-keygen

manual page, 514  
 tsig-keygen command line option  
     -a, 514  
     -h, 514  
 tsig-list  
     rndc command line option, 513  
 TTL, 30  
 type  
     delv command line option, 415  
     dig command line option, 419

## U

-U  
     host command line option, 455  
     named command line option, 493  
 -u  
     dig command line option, 420  
     dnssec-cds command line option, 430  
     dnssec-settime command line option, 445  
     dnssec-signzone command line option, 449  
     named command line option, 493  
     named-rrchecker command line option, 468  
     nsupdate command line option, 500  
     rndc-confgen command line option, 504

## V

-v  
     dnssec-cds command line option, 430  
     dnssec-dsfromkey command line option, 432  
     dnssec-importkey command line option, 433  
     dnssec-keyfromlabel command line option, 436  
     dnssec-keygen command line option, 440  
     dnssec-revoke command line option, 442  
     dnssec-settime command line option, 443  
     dnssec-signzone command line option, 447  
     dnssec-verify command line option, 451  
     host command line option, 455  
     named command line option, 494  
     nsupdate command line option, 500  
     rndc command line option, 507  
 -v  
     delv command line option, 416  
     dig command line option, 420  
     dnssec-cds command line option, 430  
     dnssec-dsfromkey command line option, 432  
     dnssec-importkey command line option, 433  
     dnssec-keyfromlabel command line option, 436  
     dnssec-keygen command line option, 440  
     dnssec-revoke command line option, 442  
     dnssec-settime command line option, 443  
     dnssec-signzone command line option, 449  
     dnssec-verify command line option, 451

host command line option, 455  
 mdig command line option, 457  
 named command line option, 494  
 named-checkconf command line option, 461  
 named-checkzone command line option, 462  
 named-compilezone command line option, 465  
     465  
     nsupdate command line option, 500  
 validation  
     rndc command line option, 513

## W

-W  
     host command line option, 455  
     named-checkzone command line option, 464  
     named-compilezone command line option, 466  
 -w  
     host command line option, 455  
     named-checkzone command line option, 464  
     named-compilezone command line option, 466

## X

-X  
     dnssec-signzone command line option, 447  
     named command line option, 494  
 -x  
     delv command line option, 416  
     dig command line option, 420  
     dnssec-signzone command line option, 449  
     dnssec-verify command line option, 452  
     dnstap-read command line option, 452  
     mdig command line option, 459  
     named-checkconf command line option, 461

## Y

-y  
     dig command line option, 420  
     dnssec-keyfromlabel command line option, 436  
     dnstap-read command line option, 452  
     nsupdate command line option, 500  
     rndc command line option, 507

## Z

-z  
     ddns-confgen command line option, 414  
     dnssec-settime command line option, 445  
     dnssec-signzone command line option, 449  
     dnssec-verify command line option, 452  
     named-checkconf command line option, 461  
 zone  
     rndc-reload command line option, 511

zonefile  
    dnssec-signzone command line option, 450  
    dnssec-verify command line option, 452  
zonename  
    named-checkzone command line option, 464  
    named-compilezone command line option,  
        466  
zonestatus  
    rndc command line option, 513